



## N-Channel 60-V (D-S) Single and Quad MOSFETs

PRODUCT SUMMARY				
Part Number	$V_{(BR)DSS}$ Min (V)	$r_{DS(on)}$ Max ( $\Omega$ )	$V_{GS(th)}$ (V)	$I_D$ (A)
2N6660	60	3 @ $V_{GS} = 10$ V	0.8 to 2	1.1
VQ1004J/P		3.5 @ $V_{GS} = 10$ V	0.8 to 2.5	0.46

### FEATURES

- Low On-Resistance: 1.3  $\Omega$
- Low Threshold: 1.7 V
- Low Input Capacitance: 35 pF
- Fast Switching Speed: 8 ns
- Low Input and Output Leakage

### BENEFITS

- Low Offset Voltage
- Low-Voltage Operation
- Easily Driven Without Buffer
- High-Speed Circuits
- Low Error Voltage

### APPLICATIONS

- Direct Logic-Level Interface: TTL/CMOS
- Drivers: Relays, Solenoids, Lamps, Hammers, Displays, Memories, Transistors, etc.
- Battery Operated Systems
- Solid-State Relays

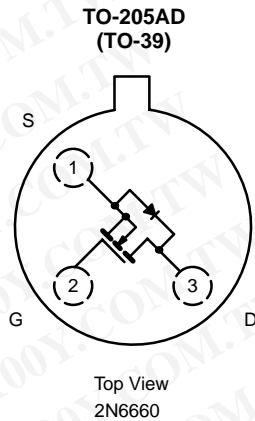

Device Marking  
Side View

2N6660  
"S" flxxyy

"S" = Siliconix Logo  
 f = Factory Code  
 // = Lot Traceability  
 xxyy = Date Code

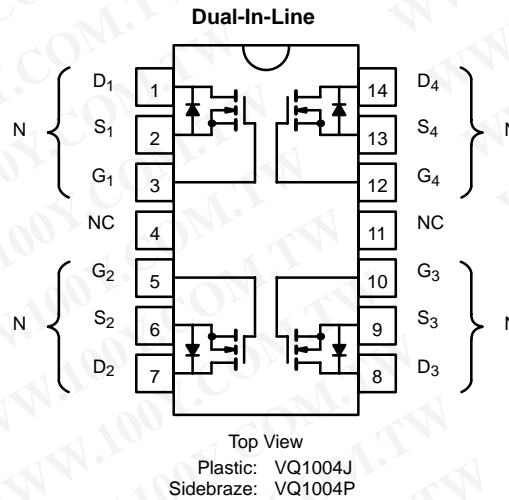

Device Marking  
Top View

VQ1004J  
"S" flxxyy

VQ1004P  
"S" flxxyy

"S" = Siliconix Logo  
 f = Factory Code  
 // = Lot Traceability  
 xxyy = Date Code

### ABSOLUTE MAXIMUM RATINGS ( $T_A = 25^\circ\text{C}$ UNLESS OTHERWISE NOTED)

Parameter	Symbol	2N6660	Single		Total Quad	Unit	
			VQ1004J	VQ1004P	VQ1004J/P		
Drain-Source Voltage	$V_{DS}$	60	60	60		V	
Gate-Source Voltage	$V_{GS}$	$\pm 20$	$\pm 30$	$\pm 20$			
Continuous Drain Current ( $T_J = 150^\circ\text{C}$ )	$I_D$	$T_C = 25^\circ\text{C}$	1.1	0.46	$\pm 0.46$	A	
		$T_C = 100^\circ\text{C}$	0.8	0.26	0.26		
Pulsed Drain Current <sup>a</sup>	$I_{DM}$	3	2	2			
Power Dissipation	$P_D$	$T_C = 25^\circ\text{C}$	6.25	1.3	1.3	2	W
		$T_C = 100^\circ\text{C}$	2.5	0.52	0.52	0.8	
Thermal Resistance, Junction-to-Ambient <sup>b</sup>	$R_{thJA}$	170	0.96	0.96	62.5	$^\circ\text{C}/\text{W}$	
Thermal Resistance, Junction-to-Case	$R_{thJC}$	20					
Operating Junction and Storage Temperature Range	$T_J, T_{stg}$	-55 to 150					$^\circ\text{C}$

Notes

- a. Pulse width limited by maximum junction temperature.  
 b. This parameter not registered with JEDEC.

**SPECIFICATIONS (T<sub>A</sub> = 25 °C UNLESS OTHERWISE NOTED)**

Parameter	Symbol	Test Conditions	Typ <sup>a</sup>	Limits				Unit
				2N6660		VQ1004J/P		
				Min	Max	Min	Max	
<b>Static</b>								
Drain-Source Breakdown Voltage	V <sub>(BR)DSS</sub>	V <sub>GS</sub> = 0 V, I <sub>D</sub> = 10 μA	75	60		60		V
Gate-Threshold Voltage	V <sub>GS(th)</sub>	V <sub>DS</sub> = V <sub>GS</sub> , I <sub>D</sub> = 1 mA	1.7	0.8	2	0.8	2.5	
Gate-Body Leakage	I <sub>GSS</sub>	V <sub>DS</sub> = 0 V, V <sub>GS</sub> = ±15 V T <sub>C</sub> = 125 °C			±100		±100	nA
					±500		±500	
Zero Gate Voltage Drain Current	I <sub>DSS</sub>	V <sub>DS</sub> = 60 V, V <sub>GS</sub> = 0 V V <sub>DS</sub> = 35 V, V <sub>GS</sub> = 0 V V <sub>DS</sub> = 48 V, V <sub>GS</sub> = 0 V T <sub>C</sub> = 125 °C			10			μA
					500		500	
On-State Drain Current <sup>b</sup>	I <sub>D(on)</sub>	V <sub>DS</sub> = 10 V, V <sub>GS</sub> = 10 V	3	1.5		1.5		A
Drain-Source On-Resistance <sup>b</sup>	r <sub>DS(on)</sub>	V <sub>GS</sub> = 5 V, I <sub>D</sub> = 0.3 A <sup>d</sup> V <sub>GS</sub> = 10 V, I <sub>D</sub> = 1 A T <sub>C</sub> = 125 °C <sup>d</sup>	2		5		5	Ω
			1.3		3		3.5	
			2.4		4.2		4.9	
Forward Transconductance <sup>b</sup>	g <sub>fs</sub>	V <sub>DS</sub> = 10 V, I <sub>D</sub> = 0.5 A	350	170		170		mS
Common Source Output Conductance <sup>b</sup>	g <sub>os</sub>	V <sub>DS</sub> = 10 V, I <sub>D</sub> = 0.1 A	1					
Diode Forward Voltage	V <sub>SD</sub>	I <sub>S</sub> = 0.99 A, V <sub>GS</sub> = 0 V	0.8					V
<b>Dynamic</b>								
Input Capacitance	C <sub>iss</sub>	V <sub>DS</sub> = 24 V, V <sub>GS</sub> = 0 V f = 1 MHz	35		50		60	pF
Output Capacitance	C <sub>oss</sub>		25		40		50	
Reverse Transfer Capacitance	C <sub>rss</sub>		7		10		10	
Drain-Source Capacitance	C <sub>ds</sub>		30		40			
<b>Switching<sup>c</sup></b>								
Turn-On Time	t <sub>ON</sub>	V <sub>DD</sub> = 25 V, R <sub>L</sub> = 23 Ω I <sub>D</sub> ≅ 1 A, V <sub>GEN</sub> = 10 V R <sub>G</sub> = 25 Ω	8		10		10	ns
Turn-Off Time	t <sub>OFF</sub>		8.5		10		10	

## Notes

- For DESIGN AID ONLY, not subject to production testing.
- Pulse test: PW ≤ 80 μs duty cycle ≤ 1%.
- Switching time is essentially independent of operating temperature.
- This parameter not registered with JEDEC on 2N6660.

VNDQ06

勝特力材料 886-3-5753170  
 勝特力电子(上海) 86-21-34970699  
 勝特力电子(深圳) 86-755-83298787  
[Http://www.100y.com.tw](http://www.100y.com.tw)



勝特力材料 886-3-5753170  
勝特力电子(上海) 86-21-34970699  
勝特力电子(深圳) 86-755-83298787  
[Http://www.100y.com.tw](http://www.100y.com.tw)

2N6660, VQ1004J/P

Vishay Siliconix

**TYPICAL CHARACTERISTICS ( $T_A = 25^\circ\text{C}$  UNLESS OTHERWISE NOTED)**

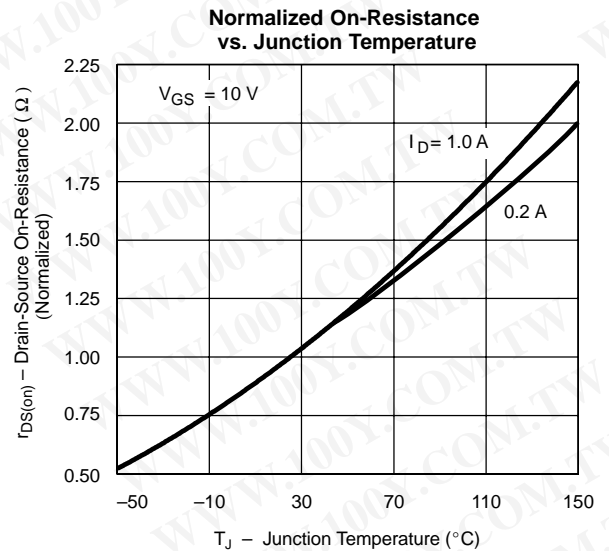
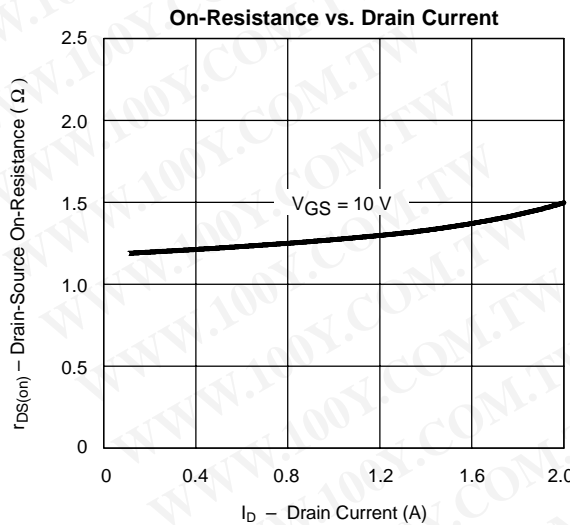
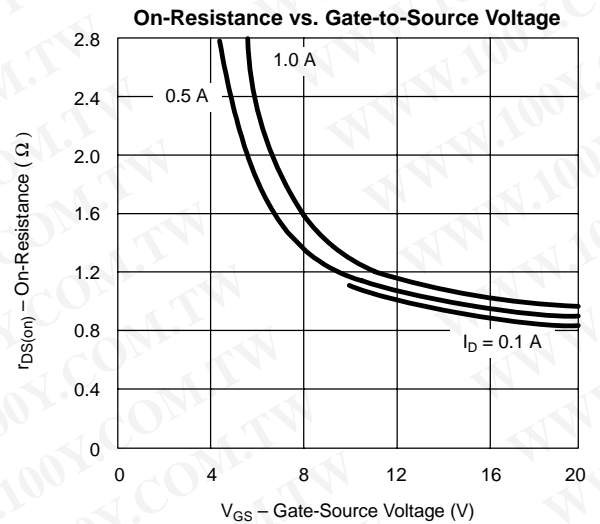
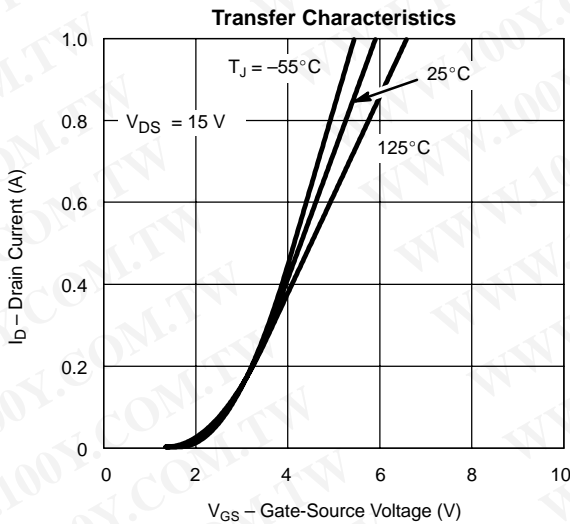
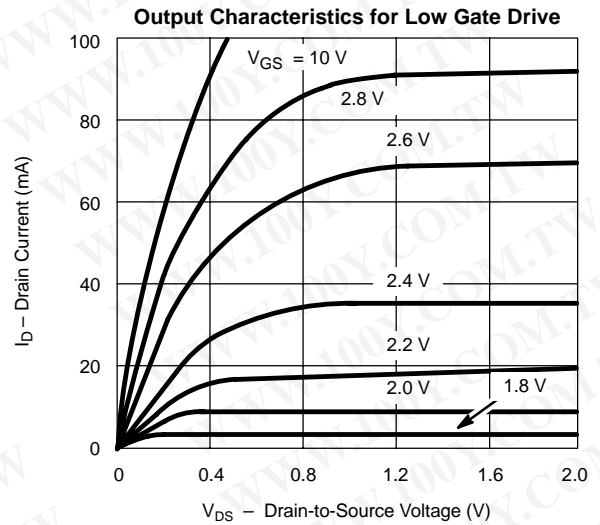
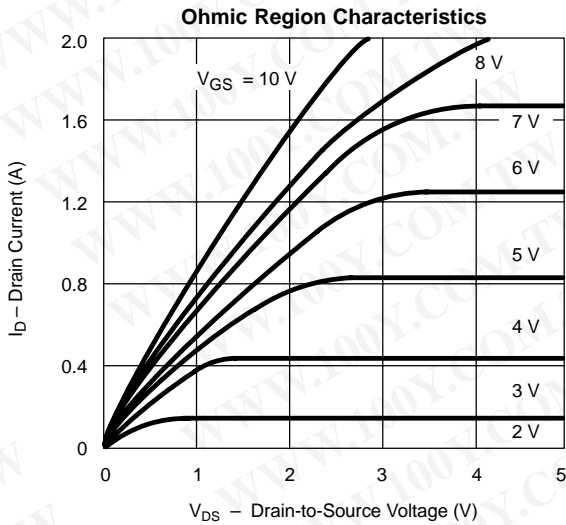



**TYPICAL CHARACTERISTICS (T<sub>A</sub> = 25°C UNLESS OTHERWISE NOTED)**

