

Small Signal Zener Diodes

勝特力材料 886-3-5753170
 勝特力电子(上海) 86-21-34970699
 勝特力电子(深圳) 86-755-83298787
[Http://www.100y.com.tw](http://www.100y.com.tw)

Features

- These diodes are also available in other case styles and other configurations including: the SOD-123 case with type designation BZT52 series, the zener diode common anode configuration in the SOT-23 case with type designation AZ23 series and the zener diode common cathode configuration in the SOT-23 case with type designation DZ23 series.
- The zener voltages are graded according to the international E 24 standard. Standard zener voltage tolerance is $\pm 5\%$. Replace "C" with "B" for 2% tolerance.
- Silicon planar power zener diodes
- AEC-Q101 qualified
- Compliant to RoHS directive 2002/95/EC and in accordance to WEEE 2002/96/EC



RoHS COMPLIANT

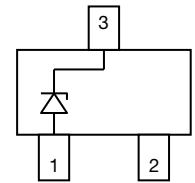
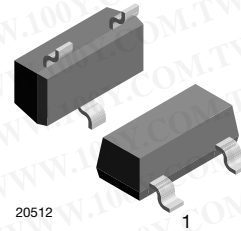

Mechanical Data

Case: SOT-23

Weight: approx. 8.8 mg

Packaging codes/options:

GS18/10 k per 13" reel, (8 mm tape), 10 k/box

GS08/3 k per 7" reel, (8 mm tape), 15 k/box

Absolute Maximum Ratings

$T_{amb} = 25\text{ }^{\circ}\text{C}$, unless otherwise specified

Parameter	Test condition	Symbol	Value	Unit
Power dissipation		P_{tot}	300 ¹⁾	mW

¹⁾ Device on fiberglass substrate, see layout on page 7.

Thermal Characteristics

$T_{amb} = 25\text{ }^{\circ}\text{C}$, unless otherwise specified

Parameter	Test condition	Symbol	Value	Unit
Thermal resistance junction to ambient air		R_{thJA}	420 ¹⁾	$^{\circ}\text{C/W}$
Junction temperature		T_j	150	$^{\circ}\text{C}$
Storage temperature range		T_{stg}	- 65 to + 150	$^{\circ}\text{C}$

¹⁾ Device on fiberglass substrate, see layout on page 7.

BZX84-V-Series



Vishay Semiconductors

Electrical Characteristics

Part number	Marking code	Zener voltage range		Dynamic resistance		Test current	Temperature coefficient of zener voltage		Test current	Reverse voltage	
		V_Z at I_{ZT1}		r_{zj} at I_{ZT1}	r_{zj} at I_{ZT2}	I_{ZT1}	α_{VZ} at I_{ZT1}		I_{ZT2}	I_R	at V_R
		V		Ω		mA	$10^{-4}/^{\circ}\text{C}$		mA	μA	V
		min.	max.				min.	max.			
BZX84C2V4-V	Z11	2.2	2.6	70 (\leq 100)	275	5	-9	-4	1	50	1
BZX84C2V7-V	Z12	2.5	2.9	75 (\leq 100)	300 (\leq 600)	5	-9	-4	1	20	1
BZX84C3V0-V	Z13	2.8	3.2	80 (\leq 95)	325 (\leq 600)	5	-9	-3	1	10	1
BZX84C3V3-V	Z14	3.1	3.5	85 (\leq 95)	350 (\leq 600)	5	-8	-3	1	5	1
BZX84C3V6-V	Z15	3.4	3.8	85 (\leq 90)	375 (\leq 600)	5	-8	-3	1	5	1
BZX84C3V9-V	Z16	3.7	4.1	85 (\leq 90)	400 (\leq 600)	5	-7	-3	1	3	1
BZX84C4V3-V	Z17	4	4.6	80 (\leq 90)	410 (\leq 600)	5	-6	-1	1	3	1
BZX84C4V7-V	Z1	4.4	5	50 (\leq 80)	425 (\leq 500)	5	-5	+2	1	3	2
BZX84C5V1-V	Z2	4.8	5.4	40 (\leq 60)	400 (\leq 480)	5	-3	+4	1	2	2
BZX84C5V6-V	Z3	5.2	6	15 (\leq 40)	80 (\leq 400)	5	-2	+6	1	1	2
BZX84C6V2-V	Z4	5.8	6.6	6 (\leq 10)	40 (\leq 150)	5	-1	+7	1	3	4
BZX84C6V8-V	Z5	6.4	7.2	6 (\leq 15)	30 (\leq 80)	5	+2	+7	1	2	4
BZX84C7V5-V	Z6	7	7.9	6 (\leq 15)	30 (\leq 80)	5	+3	+7	1	1	5
BZX84C8V2-V	Z7	7.7	8.7	6 (\leq 15)	40 (\leq 80)	5	+4	+7	1	0.7	5
BZX84C9V1-V	Z8	8.5	9.6	6 (\leq 15)	40 (\leq 100)	5	+5	+8	1	0.5	6
BZX84C10-V	Z9	9.4	10.6	8 (\leq 20)	50 (\leq 150)	5	+5	+8	1	0.2	7
BZX84C11-V	Y1	10.4	11.6	10 (\leq 20)	50 (\leq 150)	5	+5	+9	1	0.1	8
BZX84C12-V	Y2	11.4	12.7	10 (\leq 25)	50 (\leq 150)	5	+6	+9	1	0.1	8
BZX84C13-V	Y3	12.4	14.1	10 (\leq 30)	50 (\leq 170)	5	+7	+9	1	0.1	8
BZX84C15-V	Y4	13.8	15.6	10 (\leq 30)	50 (\leq 200)	5	+7	+9	1	0.05	0.7 $V_{Znom.}$
BZX84C16-V	Y5	15.3	17.1	10 (\leq 40)	50 (\leq 200)	5	+8	+9.5	1	0.05	0.7 $V_{Znom.}$
BZX84C18-V	Y6	16.8	19.1	10 (\leq 45)	50 (\leq 225)	5	+8	+9.5	1	0.05	0.7 $V_{Znom.}$
BZX84C20-V	Y7	18.8	21.2	15 (\leq 55)	60 (\leq 225)	5	+8	+10	1	0.05	0.7 $V_{Znom.}$
BZX84C22-V	Y8	20.8	23.3	20 (\leq 55)	60 (\leq 250)	5	+8	+10	1	0.05	0.7 $V_{Znom.}$
BZX84C24-V	Y9	22.8	25.6	25 (\leq 70)	60 (\leq 250)	5	+8	+10	1	0.05	0.7 $V_{Znom.}$
BZX84C27-V	Y10	25.1	28.9	25 (\leq 80)	65 (\leq 300)	2	+8	+10	0.5	0.05	0.7 $V_{Znom.}$
BZX84C30-V	Y11	28	32	30 (\leq 80)	70 (\leq 300)	2	+8	+10	0.5	0.05	0.7 $V_{Znom.}$
BZX84C33-V	Y12	31	35	35 (\leq 80)	75 (\leq 325)	2	+8	+10	0.5	0.05	0.7 $V_{Znom.}$
BZX84C36-V	Y13	34	38	35 (\leq 90)	80 (\leq 350)	2	+8	+10	0.5	0.05	0.7 $V_{Znom.}$
BZX84C39-V	Y14	37	41	40 (\leq 130)	80 (\leq 350)	2	+10	+12	0.5	0.05	0.7 $V_{Znom.}$
BZX84C43-V	Y15	40	46	45 (\leq 150)	85 (\leq 375)	2	+10	+12	0.5	0.05	0.7 $V_{Znom.}$
BZX84C47-V	Y16	44	50	50 (\leq 170)	85 (\leq 375)	2	+10	+12	0.5	0.05	0.7 $V_{Znom.}$
BZX84C51-V	Y17	48	54	60 (\leq 180)	85 (\leq 400)	2	+10	+12	0.5	0.05	0.7 $V_{Znom.}$
BZX84C56-V	Y18	52	60	70 (\leq 200)	100 (\leq 425)	2	+9	+11	0.5	0.05	0.7 $V_{Znom.}$
BZX84C62-V	Y19	58	66	80 (\leq 215)	100 (\leq 450)	2	+9	+12	0.5	0.05	0.7 $V_{Znom.}$
BZX84C68-V	Y20	64	72	90 (\leq 240)	150 (\leq 475)	2	+10	+12	0.5	0.05	0.7 $V_{Znom.}$
BZX84C75-V	Y21	70	79	95 (\leq 255)	170 (\leq 500)	2	+10	+12	0.5	0.05	0.7 $V_{Znom.}$



Electrical Characteristics

Part number	Marking code	Zener voltage range		Dynamic resistance		Test current	Temperature coefficient of zener voltage		Test current	Reverse voltage	
		V_Z at I_{ZT1}		r_{zj} at I_{ZT1}	r_{zj} at I_{ZT2}	I_{ZT1}	α_{VZ} at I_{ZT1}		I_{ZT2}	I_R	at V_R
		V		Ω		mA	$10^{-4}/^{\circ}\text{C}$		mA	μA	V
		min.	max.				min.	max.			
BZX84B2V4-V	Z50	2.35	2.45	70 (≤ 100)	275	5	-9	-4	1	50	1
BZX84B2V7-V	Z51	2.65	2.75	75 (≤ 100)	300 (≤ 600)	5	-9	-4	1	20	1
BZX84B3V0-V	Z52	2.94	3.06	80 (≤ 95)	325 ($= 600$)	5	-9	-3	1	10	1
BZX84B3V3-V	Z53	3.23	3.37	85 (≤ 95)	350 (≤ 600)	5	-8	-3	1	5	1
BZX84B3V6-V	Z54	3.53	3.67	85 (≤ 90)	375 (≤ 600)	5	-8	-3	1	5	1
BZX84B3V9-V	Z55	3.82	3.98	85 (≤ 90)	400 (≤ 600)	5	-7	-3	1	3	1
BZX84B4V3-V	Z56	4.21	4.39	80 (≤ 90)	410 (≤ 600)	5	-6	-1	1	3	1
BZX84B4V7-V	Z57	4.61	4.79	50 (≤ 80)	425 (≤ 500)	5	-5	2	1	3	2
BZX84B5V1-V	Z58	5	5.2	40 (≤ 60)	400 (≤ 480)	5	-3	4	1	2	2
BZX84B5V6-V	Z59	5.49	5.71	15 (≤ 40)	80 (≤ 400)	5	-2	6	1	1	2
BZX84B6V2-V	Z60	6.08	6.32	6 (≤ 10)	40 (≤ 150)	5	-1	7	1	3	4
BZX84B6V8-V	Z61	6.66	6.94	6 (≤ 15)	30 (≤ 80)	5	2	7	1	2	4
BZX84B7V5-V	Z62	7.35	7.65	6 (≤ 15)	30 (≤ 80)	5	3	7	1	1	5
BZX84B8V2-V	Z63	8.04	8.36	6 (≤ 15)	40 (≤ 80)	5	4	7	1	0.7	5
BZX84B9V1-V	Z64	8.92	9.28	6 (≤ 15)	40 (≤ 100)	5	5	8	1	0.5	6
BZX84B10-V	Z65	9.8	10.2	8 (≤ 20)	50 (≤ 150)	5	5	8	1	0.2	7
BZX84B11-V	Z66	10.8	11.2	10 (≤ 20)	50 (≤ 150)	5	5	9	1	0.1	8
BZX84B12-V	Z67	11.8	12.2	10 (≤ 25)	50 (≤ 150)	5	6	9	1	0.1	8
BZX84B13-V	Z68	12.7	13.3	10 (≤ 30)	50 (≤ 170)	5	7	9	1	0.1	8
BZX84B15-V	Z69	14.7	15.3	10 (≤ 30)	50 (≤ 200)	5	7	9	1	0.05	$0.7 V_{Znom.}$
BZX84B16-V	Z70	15.7	16.3	10 (≤ 40)	50 (≤ 200)	5	8	9.5	1	0.05	$0.7 V_{Znom.}$
BZX84B18-V	Z71	17.6	18.4	10 (≤ 45)	50 (≤ 225)	5	8	9.5	1	0.05	$0.7 V_{Znom.}$
BZX84B20-V	Z72	19.6	20.4	15 (≤ 55)	60 (≤ 225)	5	8	10	1	0.05	$0.7 V_{Znom.}$
BZX84B22-V	Z73	21.6	22.4	20 (≤ 55)	60 (≤ 250)	5	8	10	1	0.05	$0.7 V_{Znom.}$
BZX84B24-V	Z74	23.5	24.5	25 (≤ 70)	60 (≤ 250)	5	8	10	1	0.05	$0.7 V_{Znom.}$
BZX84B27-V	Z75	26.5	27.5	25 (≤ 80)	65 (≤ 300)	2	8	10	0.5	0.05	$0.7 V_{Znom.}$
BZX84B30-V	Z76	29.4	30.6	30 (≤ 80)	70 (≤ 300)	2	8	10	0.5	0.05	$0.7 V_{Znom.}$
BZX84B33-V	Z77	32.3	33.7	35 (≤ 80)	75 (≤ 325)	2	8	10	0.5	0.05	$0.7 V_{Znom.}$
BZX84B36-V	Z78	35.3	36.7	35 (≤ 90)	80 (≤ 350)	2	8	10	0.5	0.05	$0.7 V_{Znom.}$
BZX84B39-V	Z79	38.2	39.8	40 (≤ 130)	80 (≤ 350)	2	10	12	0.5	0.05	$0.7 V_{Znom.}$
BZX84B43-V	Z80	42.1	43.9	45 (≤ 150)	85 (≤ 375)	2	10	12	0.5	0.05	$0.7 V_{Znom.}$
BZX84B47-V	Z81	46.1	47.9	50 (≤ 170)	85 (≤ 375)	2	10	12	0.5	0.05	$0.7 V_{Znom.}$
BZX84B51-V	Z82	50	52	60 (≤ 180)	85 (≤ 400)	2	10	12	0.5	0.05	$0.7 V_{Znom.}$
BZX84B56-V	Z83	54.9	57.1	70 (≤ 200)	100 (≤ 425)	2	9	11	0.5	0.05	$0.7 V_{Znom.}$
BZX84B62-V	Z84	60.8	63.2	80 (≤ 215)	100 (≤ 450)	2	9	12	0.5	0.05	$0.7 V_{Znom.}$
BZX84B68-V	Z85	66.6	69.4	90 (≤ 240)	150 (≤ 475)	2	10	12	0.5	0.05	$0.7 V_{Znom.}$
BZX84B75-V	Z86	73.5	76.5	95 (≤ 255)	170 (≤ 500)	2	10	12	0.5	0.05	$0.7 V_{Znom.}$

Typical Characteristics ($T_{amb} = 25\text{ }^{\circ}\text{C}$, unless otherwise specified)

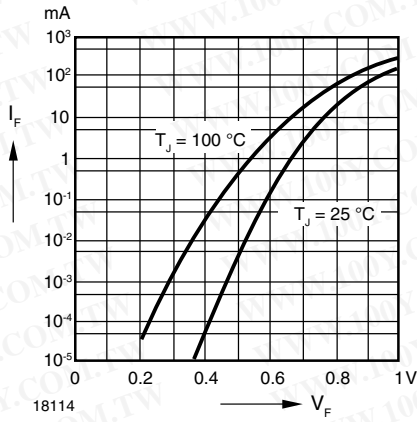

Figure 1. Forward characteristics

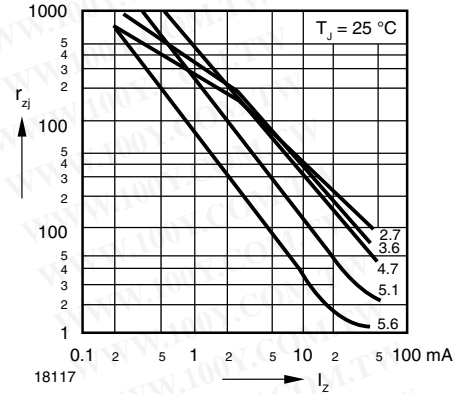

Figure 4. Dynamic Resistance vs. Zener Current

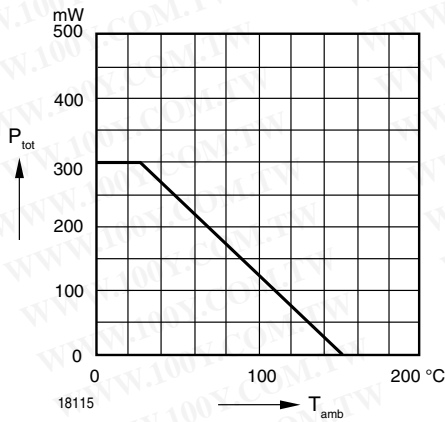

Figure 2. Admissible Power Dissipation vs. Ambient Temperature

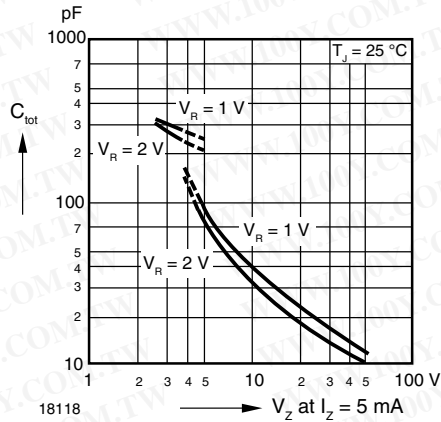

Figure 5. Capacitance vs. Zener Voltage

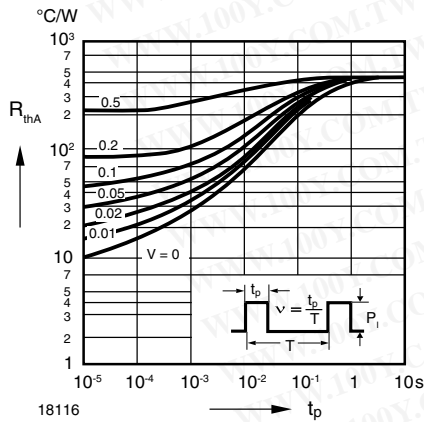

Figure 3. Pulse Thermal Resistance vs. Pulse Duration

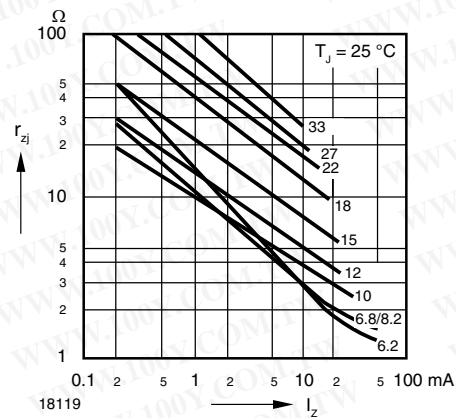

Figure 6. Dynamic Resistance vs. Zener Current

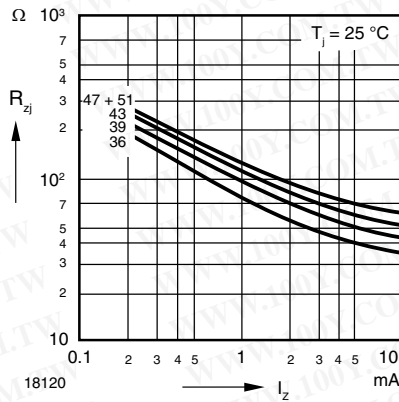

Figure 7. Dynamic Resistance vs. Zener Current

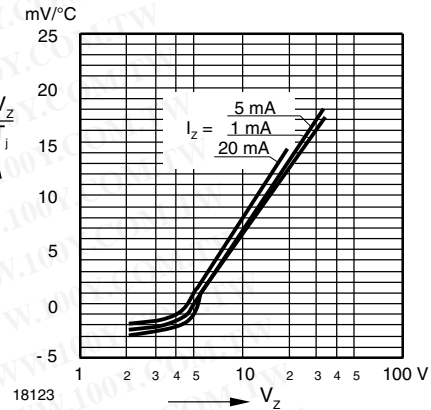

Figure 10. Temperature Dependence of Zener Voltage vs. Zener Voltage

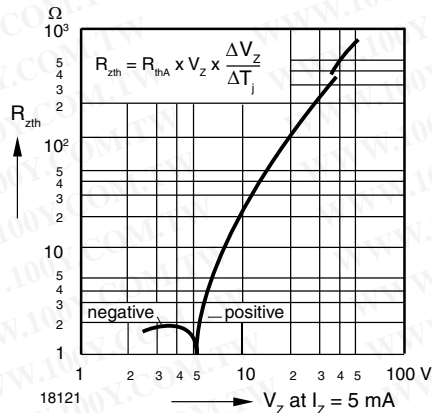

Figure 8. Thermal Differential Resistance vs. Zener Voltage

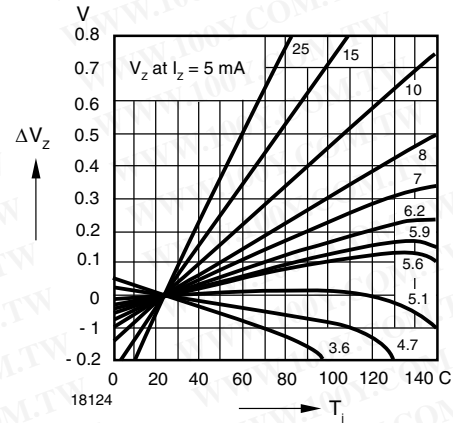

Figure 11. Change of Zener Voltage vs. Junction Temperature

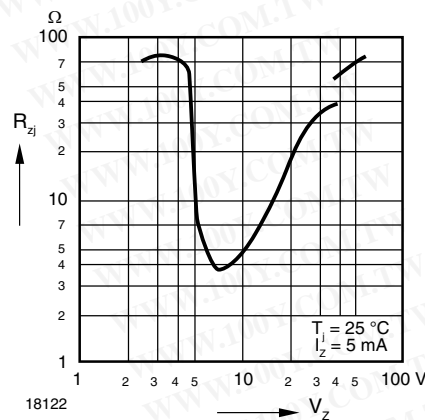

Figure 9. Dynamic Resistance vs. Zener Voltage

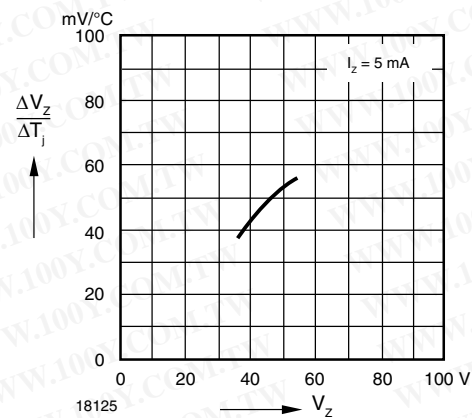

Figure 12. Temperature Dependence of Zener Voltage vs. Zener Voltage

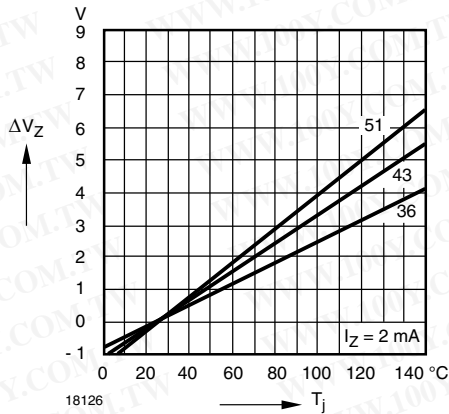

Figure 13. Change of Zener Voltage vs. Junction Temperature

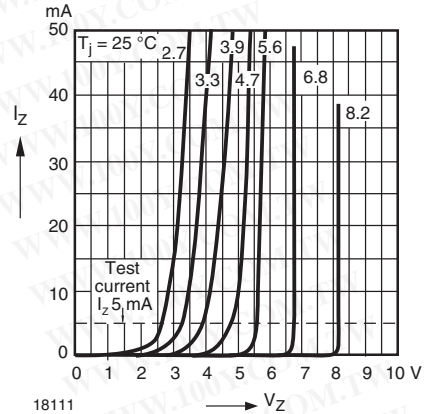

Figure 16. Breakdown Characteristics

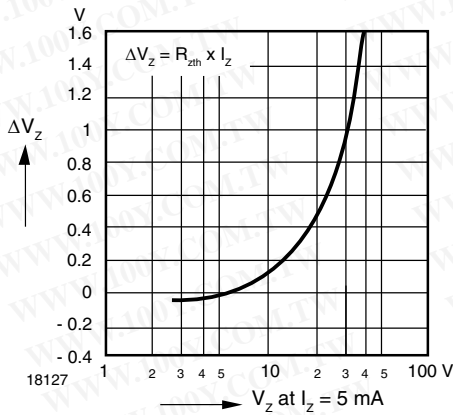

Figure 14. Change of Zener voltage from turn-on up to the point of thermal equilibrium vs. Zener voltage

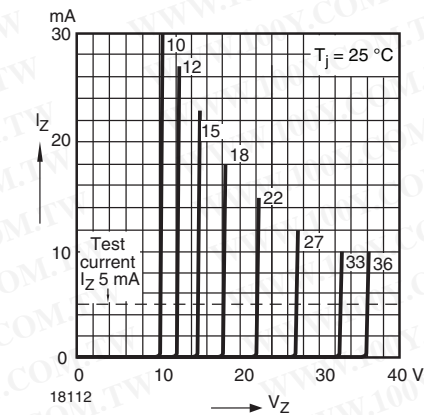

Figure 17. Breakdown Characteristics

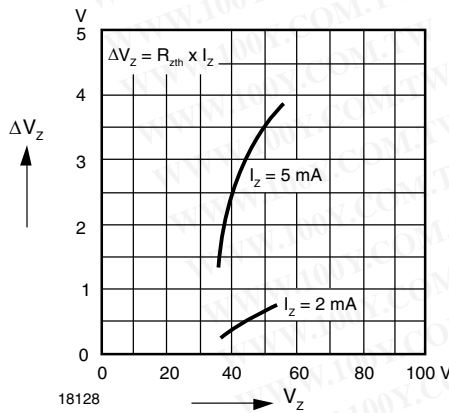

Figure 15. Change of Zener voltage from turn-on up to the point of thermal equilibrium vs. Zener voltage

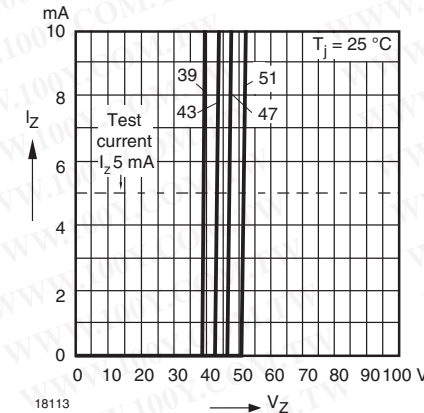
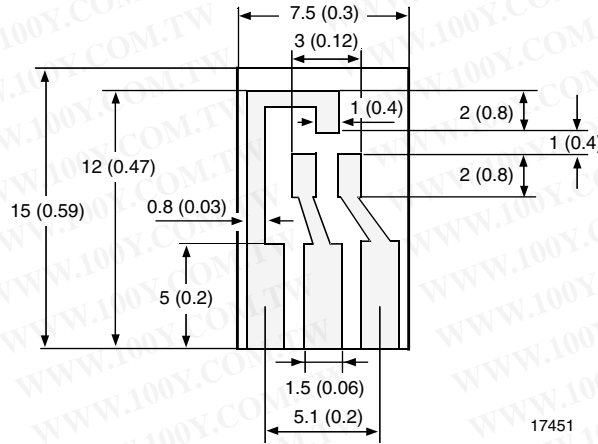

Figure 18. Breakdown Characteristics

Layout for R_{thJA} test

Thickness: fiberglass 0.059 in. (1.5 mm)

Copper leads 0.012 in. (0.3 mm)



Package Dimensions in millimeters (inches): SOT-23

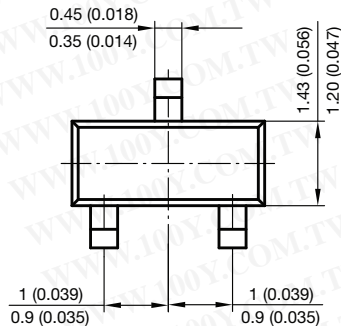
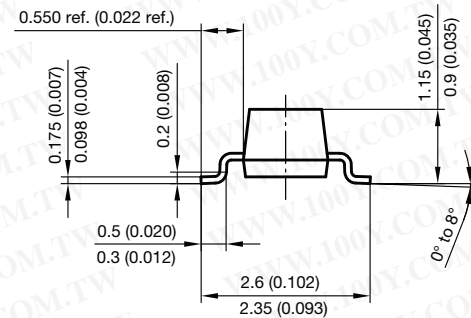
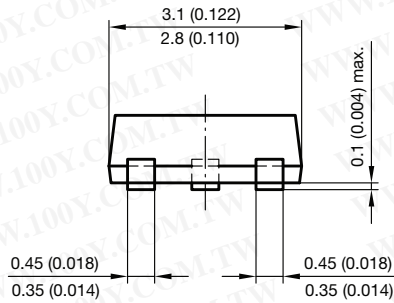

Foot print recommendation:

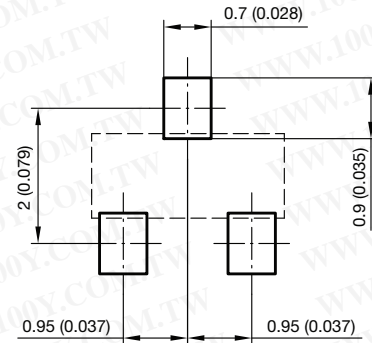

Document no.: 6.541-5014.01-4

Rev. 8 - Date: 23.Sept.2009

17418



勝特力材料 886-3-5753170
勝特力电子(上海) 86-21-34970699
勝特力电子(深圳) 86-755-83298787
[Http://www.100y.com.tw](http://www.100y.com.tw)

Disclaimer

ALL PRODUCT, PRODUCT SPECIFICATIONS AND DATA ARE SUBJECT TO CHANGE WITHOUT NOTICE TO IMPROVE RELIABILITY, FUNCTION OR DESIGN OR OTHERWISE.

Vishay Intertechnology, Inc., its affiliates, agents, and employees, and all persons acting on its or their behalf (collectively, "Vishay"), disclaim any and all liability for any errors, inaccuracies or incompleteness contained in any datasheet or in any other disclosure relating to any product.

Vishay makes no warranty, representation or guarantee regarding the suitability of the products for any particular purpose or the continuing production of any product. To the maximum extent permitted by applicable law, Vishay disclaims (i) any and all liability arising out of the application or use of any product, (ii) any and all liability, including without limitation special, consequential or incidental damages, and (iii) any and all implied warranties, including warranties of fitness for particular purpose, non-infringement and merchantability.

Statements regarding the suitability of products for certain types of applications are based on Vishay's knowledge of typical requirements that are often placed on Vishay products in generic applications. Such statements are not binding statements about the suitability of products for a particular application. It is the customer's responsibility to validate that a particular product with the properties described in the product specification is suitable for use in a particular application. Parameters provided in datasheets and/or specifications may vary in different applications and performance may vary over time. All operating parameters, including typical parameters, must be validated for each customer application by the customer's technical experts. Product specifications do not expand or otherwise modify Vishay's terms and conditions of purchase, including but not limited to the warranty expressed therein.

Except as expressly indicated in writing, Vishay products are not designed for use in medical, life-saving, or life-sustaining applications or for any other application in which the failure of the Vishay product could result in personal injury or death. Customers using or selling Vishay products not expressly indicated for use in such applications do so at their own risk and agree to fully indemnify and hold Vishay and its distributors harmless from and against any and all claims, liabilities, expenses and damages arising or resulting in connection with such use or sale, including attorneys fees, even if such claim alleges that Vishay or its distributor was negligent regarding the design or manufacture of the part. Please contact authorized Vishay personnel to obtain written terms and conditions regarding products designed for such applications.

No license, express or implied, by estoppel or otherwise, to any intellectual property rights is granted by this document or by any conduct of Vishay. Product names and markings noted herein may be trademarks of their respective owners.