

SKKT 122, SKKH 122



SEMIPACK[®] 2

Thyristor / Diode Modules

SKKT 122

SKKH 122

Features

- Heat transfer through aluminium oxide ceramic isolated metal baseplate
- Hard soldered joints for high reliability
- UL recognized, file no. E 63 532

Typical Applications*

- DC motor control (e. g. for machine tools)
- Softstarter
- Temperature control (e. g. for ovens, chemical processes)
- Professional light dimming (studios, theaters)

1) See the assembly instructions

V_{RSM} V	V_{RRM}, V_{DRM} V	$I_{TRMS} = 195$ A (maximum value for continuous operation) $I_{TAV} = 122$ A (sin. 180; $T_c = 88$ °C)	
900	800	SKKT 122/08E	SKKH 122/08E
1300	1200	SKKT 122/12E	SKKH 122/12E
1500	1400	SKKT 122/14E	SKKH 122/14E
1700	1600	SKKT 122/16E	SKKH 122/16E
1900	1800	SKKT 122/18E	SKKH 122/18E

Symbol	Conditions	Values	Units
I_{TAV}	sin. 180; $T_c = 85$ (100) °C;	129 (92)	A
I_D	P3/180; $T_a = 45$ °C; B2 / B6	82 / 105	A
	P3/180F; $T_a = 35$ °C; B2 / B6	170 / 200	A
I_{RMS}	P3/180F; $T_a = 35$ °C; W1 / W3	235 / 3 * 160	A
I_{TSM}	$T_{vj} = 25$ °C; 10 ms	3600	A
	$T_{vj} = 125$ °C; 10 ms	3200	A
i^2t	$T_{vj} = 25$ °C; 8,3 ... 10 ms	64800	A ² s
	$T_{vj} = 125$ °C; 8,3 ... 10 ms	51200	A ² s
V_T	$T_{vj} = 25$ °C; $I_T = 360$ A	max. 1,55	V
$V_{T(TO)}$	$T_{vj} = 125$ °C	max. 0,85	V
r_T	$T_{vj} = 125$ °C	max. 2	mΩ
$I_{DD}; I_{RD}$	$T_{vj} = 125$ °C; $V_{RD} = V_{RRM}; V_{DD} = V_{DRM}$	max. 40	mA
t_{gd}	$T_{vj} = 25$ °C; $I_G = 1$ A; $di_G/dt = 1$ A/μs	1	μs
t_{gr}	$V_D = 0,67 * V_{DRM}$	2	μs
$(di/dt)_{cr}$	$T_{vj} = 125$ °C	max. 200	A/μs
$(dv/dt)_{cr}$	$T_{vj} = 125$ °C	max. 1000	V/μs
t_q	$T_{vj} = 125$ °C	120	μs
I_H	$T_{vj} = 25$ °C; typ. / max.	100 / 300	mA
I_L	$T_{vj} = 25$ °C; $R_G = 33$ Ω; typ. / max.	200 / 500	mA
V_{GT}	$T_{vj} = 25$ °C; d.c.	min. 2	V
I_{GT}	$T_{vj} = 25$ °C; d.c.	min. 150	mA
V_{GD}	$T_{vj} = 125$ °C; d.c.	max. 0,25	V
I_{GD}	$T_{vj} = 125$ °C; d.c.	max. 10	mA
$R_{th(j-c)}$	cont.; per thyristor / per module	0,2 / 0,1	K/W
	sin. 180; per thyristor / per module	0,21 / 0,105	K/W
	rec.120; per thyristor / per module	0,22 / 0,11	K/W
$R_{th(c-s)}$	per thyristor / per module	0,13 / 0,065	K/W
T_{vj}		- 40 ... + 125	°C
T_{stg}		- 40 ... + 125	°C
V_{isol}	a. c. 50 Hz; r.m.s.; 1 s / 1 min.	3600 / 3000	V~
M_s	to heatsink	5 ± 15 % ¹⁾	Nm
M_t	to terminal	5 ± 15 %	Nm
a		5 * 9,81	m/s ²
m	approx.	165	g
Case	SKKT	A 21	
	SKKH	A 22	

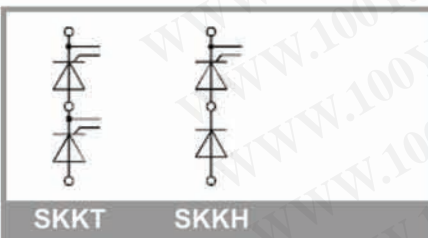

勝特力材料 886-3-5753170
 勝特力电子(上海) 86-21-34970699
 勝特力电子(深圳) 86-755-83298787
[Http://www.100y.com.tw](http://www.100y.com.tw)

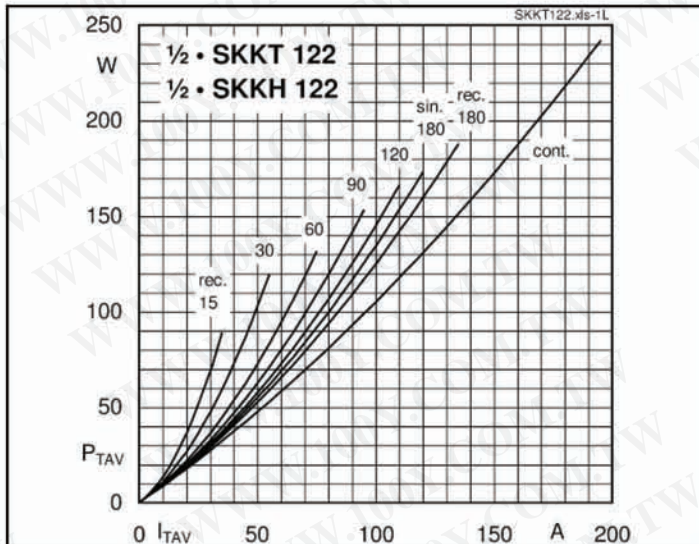

Fig. 1L Power dissipation per thyristor vs. on-state current

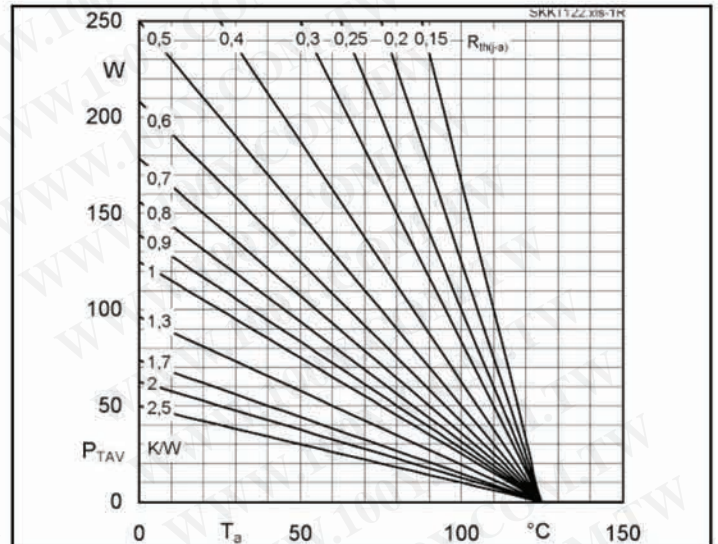

Fig. 1R Power dissipation per thyristor vs. ambient temp.

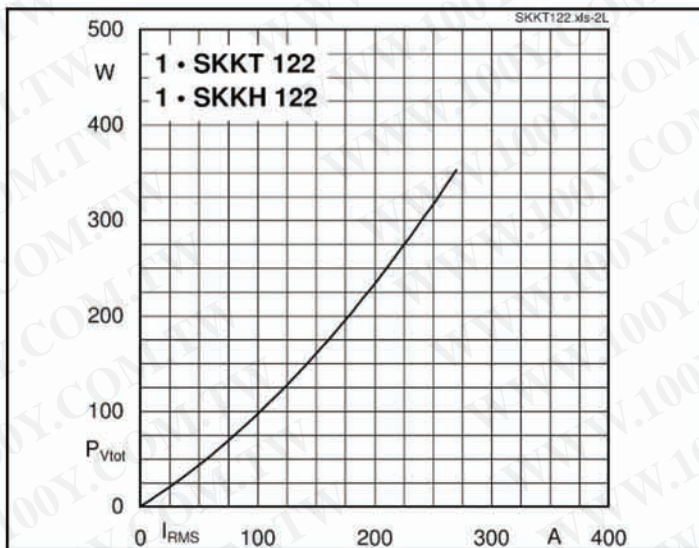

Fig. 2L Power dissipation per module vs. rms current

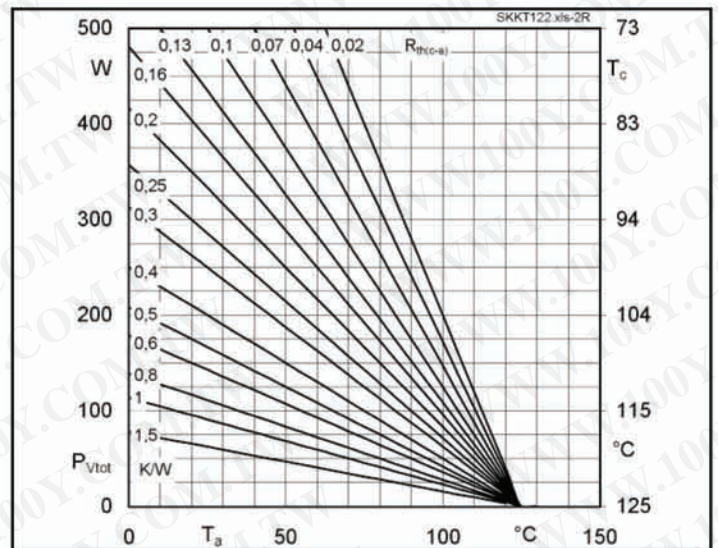

Fig. 2R Power dissipation per module vs. case temp.

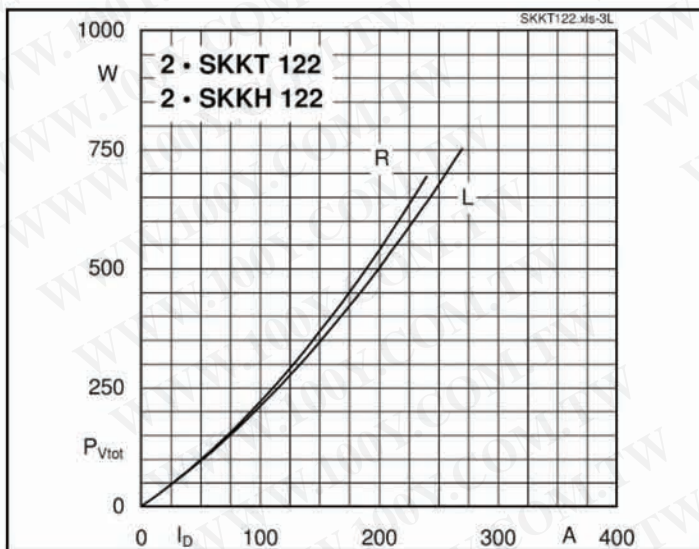

Fig. 3L Power dissipation of two modules vs. direct current

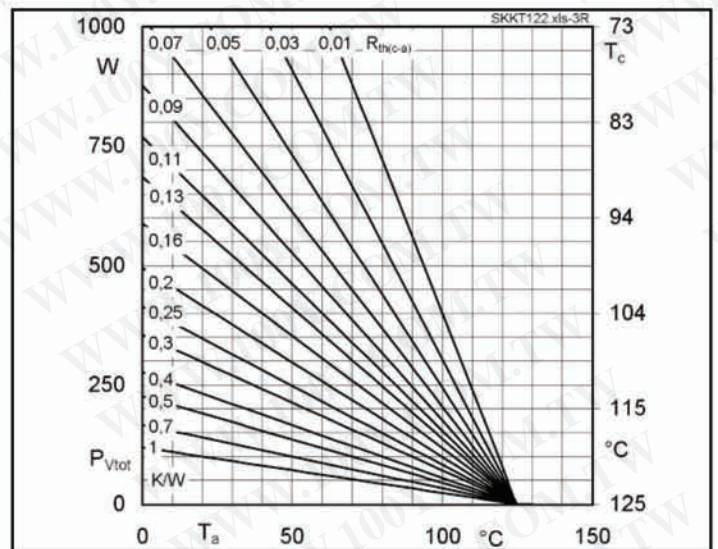

Fig. 3R Power dissipation of two modules vs. case temp.

勝特力材料 866-3-5753170
 勝特力电子(上海) 86-21-34970699
 勝特力电子(深圳) 86-755-83298787
[Http://www.100y.com.tw](http://www.100y.com.tw)

SKKT 122, SKKH 122

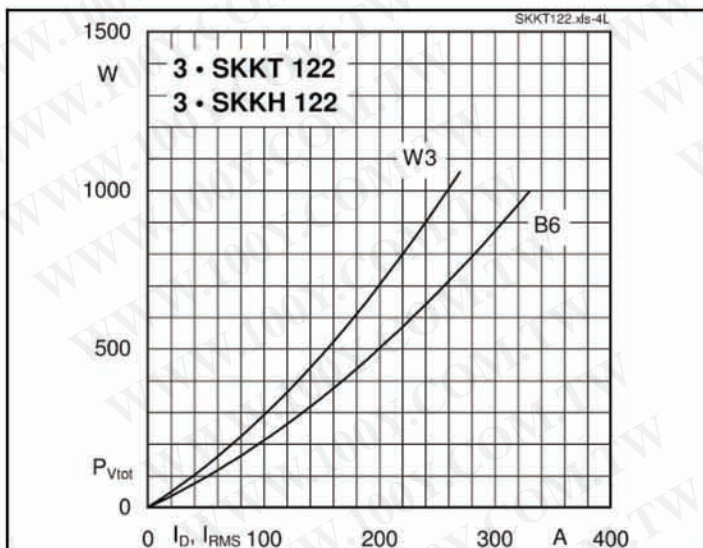

Fig. 4L Power dissipation of three modules vs. direct and rms current

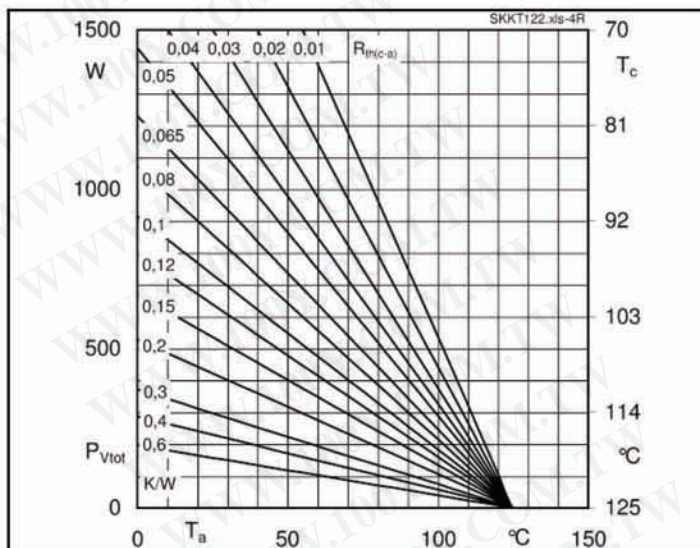

Fig. 4R Power dissipation of three modules vs. case temp.

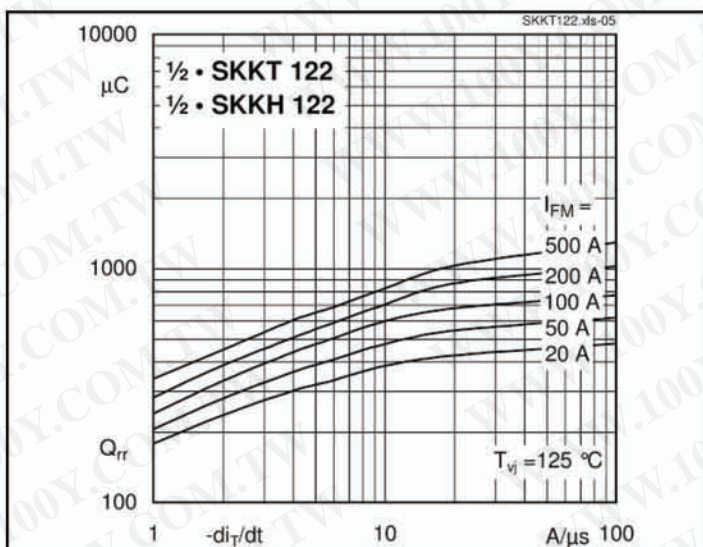

Fig. 5 Recovered charge vs. current decrease

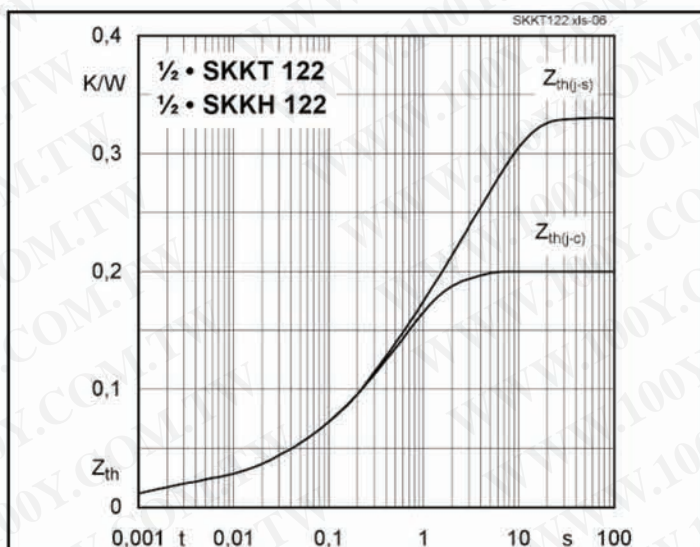

Fig. 6 Transient thermal impedance vs. time

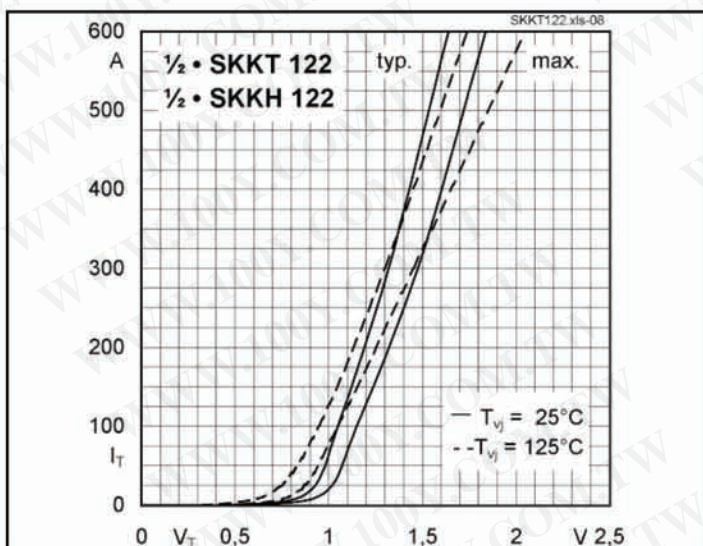

Fig. 7 On-state characteristics

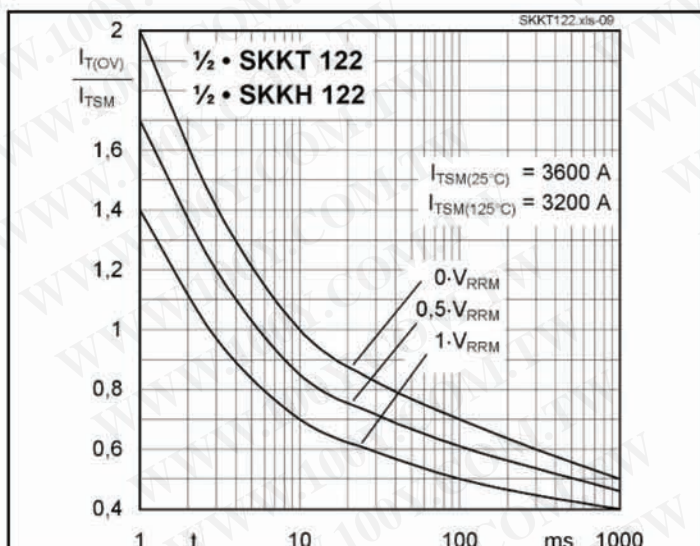
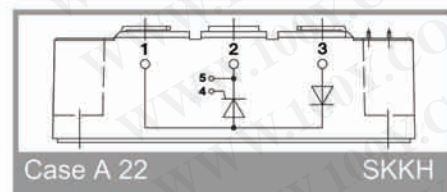
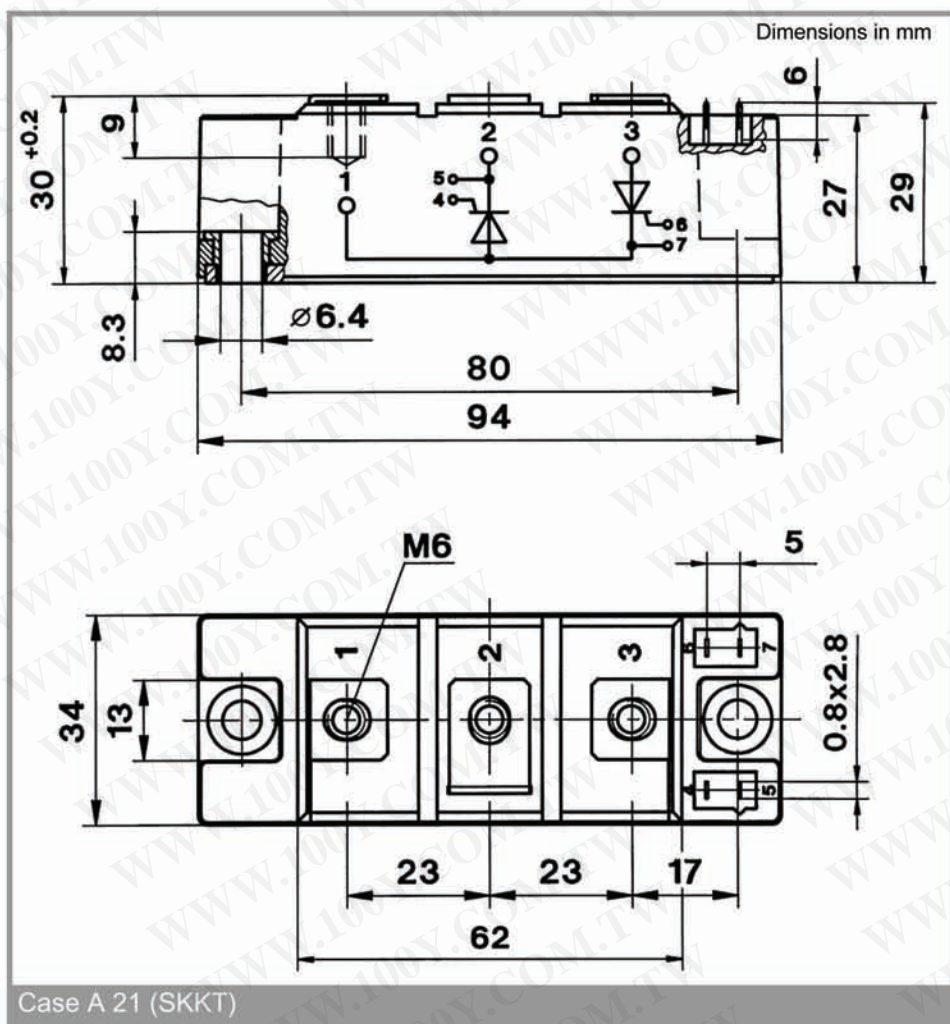
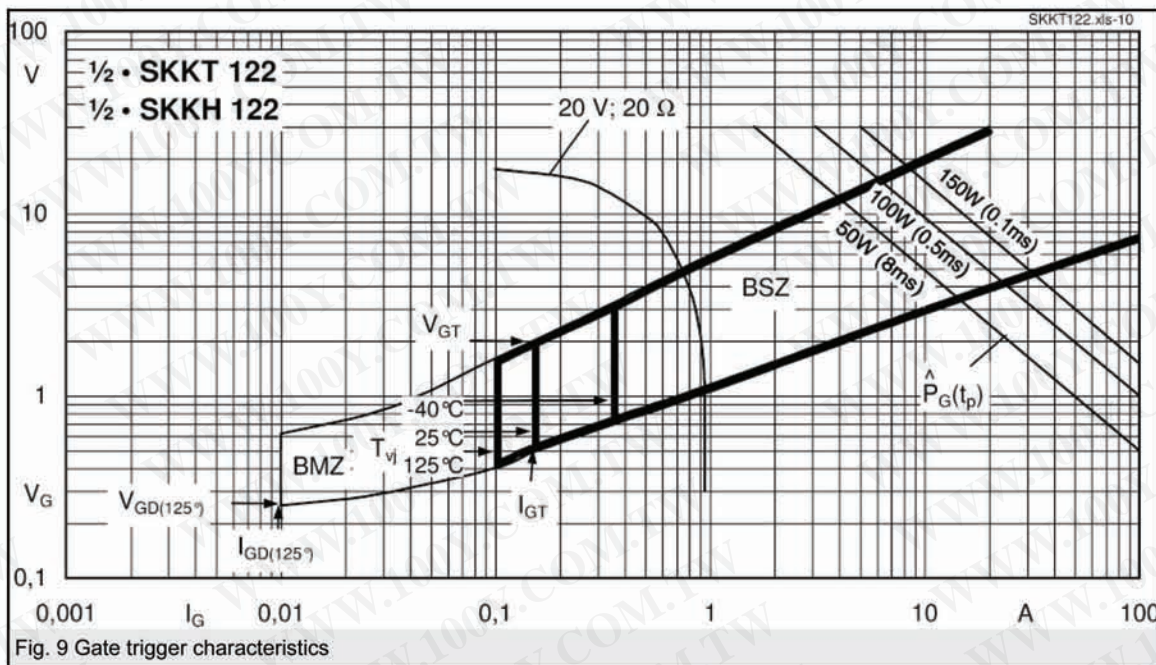

Fig. 8 Surge overload current vs. time

勝特力材料 886-3-5753170
 勝特力电子(上海) 86-21-34970699
 勝特力电子(深圳) 86-755-83298787
[Http://www.100y.com.tw](http://www.100y.com.tw)



勝特力材料 886-3-5753170
 勝特力电子(上海) 86-21-34970699
 勝特力电子(深圳) 86-755-83298787
[Http://www.100y.com.tw](http://www.100y.com.tw)

* The specifications of our components may not be considered as an assurance of component characteristics. Components have to be tested for the respective application. Adjustments may be necessary. The use of SEMIKRON