

勝特力材料 886-3-5753170
 勝特力电子(上海) 86-21-34970699
 勝特力电子(深圳) 86-755-83298787
 Http://www.100y.com.tw

2 A (4 Ar.m.s.) THYRISTOR

<R> DESCRIPTION

The 2P4M and 2P6M are a P gate all diffused mold type Thyristor granted 2 A On-state Average Current ($T_c = 77^\circ\text{C}$), with rated voltages up to 600 V.

FEATURES

- Easy installation by TO-202AA package.
- Less holding current distribution provides free application design.

APPLICATIONS

- Electric blanket, Electronic jar, Various temperature control.
- Electric sewing machine, Speed control of miniature type motor.
- Light display equipment, Lamp dimmer such as a display for entertainment.
- Automatic gas lighter, Battery charger.
- Solid state static switches etc.

<R> PACKAGE DRAWING (Unit: mm)

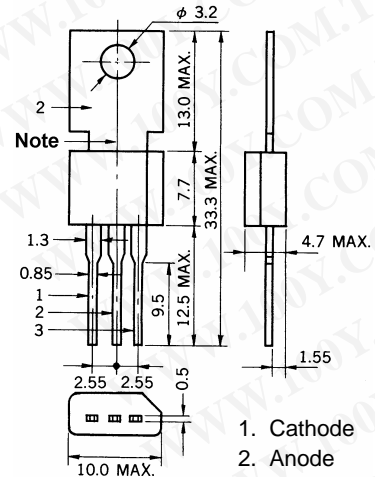

1. Cathode
 2. Anode
 3. Gate
- Standard weight : 1.4g

Note T_c test point

The information in this document is subject to change without notice. Before using this document, please confirm that this is the latest version.
 Not all products and/or types are available in every country. Please check with an NEC Electronics sales representative for availability and additional information.

<R> **MAXIMUM RATINGS**

CHARACTERISTICS	SYMBOL	2P4M	2P6M	UNIT	REMARK
Non-repetitive Peak Reverse Voltage ^{Note}	V_{RSM}	500	700	V	$R_{GK} = 1\text{ k}\Omega$
Non-repetitive Peak Off-state Voltage ^{Note}	V_{DSM}	500	700	V	$R_{GK} = 1\text{ k}\Omega$
Repetitive Peak Reverse Voltage ^{Note}	V_{RRM}	400	600	V	$R_{GK} = 1\text{ k}\Omega$
Repetitive Peak Off-state Voltage ^{Note}	V_{DRM}	400	600	V	$R_{GK} = 1\text{ k}\Omega$
On-state Current	$I_{T(AV)}$	2 ($T_c = 77^\circ\text{C}$, $\theta = 180^\circ$, Single phase half wave)		A	See Fig. 3, Fig. 4
Effective On-state Current	$I_{T(RMS)}$	4		A	-
Surge Non-repetitive On-state Current	I_{TSM}	20 (f = 50 Hz, sin half wave, 1 cycle)		A	See Fig. 10
Fusing Current	$\int i^2 dt$	1.6 (1 ms $\leq t \leq 10$ ms)		A ² s	-
Critical Rate Rise of On-state Current	di_T/dt	50		A/ μ s	-
Peak Gate Power Dissipation	P_{GM}	0.5 (f ≥ 50 Hz, Duty $\leq 10\%$)		W	-
Average Gate Power Dissipation	$P_{G(AV)}$	0.1		W	-
Peak Gate Forward Current	I_{FGM}	0.2 (f ≥ 50 Hz, Duty $\leq 10\%$)		A	-
Peak Gate Reverse Voltage	V_{RGM}	6		V	-
Junction Temperature	T_j	-40 to +125		$^\circ\text{C}$	-
Storage Temperature	T_{stg}	-55 to +150		$^\circ\text{C}$	-

Note T_c : Case Temperature is measured at 1.5 mm from the neck of Tablet.

<R> **ELECTRICAL CHARACTERISTICS ($T_A = 25^\circ\text{C}$, $R_{GK} = 1\text{ k}\Omega$)**

CHARACTERISTICS	SYMBOL	TEST CONDITIONS	MIN.	TYP.	MAX.	UNIT	REMARK	
Repetitive Peak Reverse Current ^{Note}	I_{RRM}	$V_{RM} = V_{RRM}$,	$T_j = 25^\circ\text{C}$	-	-	10	μA	-
			$T_j = 125^\circ\text{C}$	-	-	100	-	-
Repetitive Peak Off-state Current ^{Note}	I_{DRM}	$V_{DM} = V_{DRM}$,	$T_j = 25^\circ\text{C}$	-	-	10	μA	-
			$T_j = 125^\circ\text{C}$	-	-	100	-	-
Critical Rate Rise of Off-state Voltage	dV_D/dt	$T_j = 125^\circ\text{C}$, $V_{DM} = 2/3 V_{DRM}$	10	-	-	V/ μ s	2P4M	
			-	10	-	-	2P6M	
On-state Voltage	V_{TM}	$I_{TM} = 4\text{ A}$	-	-	2.2	V	See Fig. 1	
Gate-trigger Current ^{Note}	I_{GT}	$V_{DM} = 6\text{ V}$, $R_L = 100\ \Omega$,	-	-	200	μA	See Fig. 5, Fig. 7	
Gate-trigger Voltage ^{Note}	V_{GT}	$V_{DM} = 6\text{ V}$, $R_L = 100\ \Omega$,	-	-	0.8	V	See Fig. 6, Fig. 8	
Gate Non-trigger Voltage ^{Note}	V_{GD}	$V_{DM} = 1/2 V_{DRM}$, $T_j = 125^\circ\text{C}$,	0.2	-	-	V	-	
Holding Current ^{Note}	I_H	$V_{DM} = 24\text{ V}$, $I_{TM} = 4\text{ A}$	-	1	3	mA	See Fig. 9	
Circuit Commuted Turn-off Time	t_q	$T_j = 125^\circ\text{C}$, $I_{TM} = 500\text{ mA}$, $di_T/dt = 15\text{ A}/\mu\text{s}$, $V_R \geq 25\text{ V}$, $V_{DM} = 2/3 V_{DRM}$, $dV_D/dt = 10\text{ V}/\mu\text{s}$	-	30	-	μs	-	
Thermal Resistance	$R_{th(j-c)}$	Junction to case DC	-	-	10	$^\circ\text{C}/\text{W}$	See Fig. 11	
	$R_{th(j-a)}$	Junction to ambient DC	-	-	75			

Note Insert a resistance less than 1 k Ω between gate and cathode, because the items indicated are guaranteed by connecting short resistance between gate and cathode ($R_{GK} = 1\text{ k}\Omega$).

TYPICAL CHARACTERISTICS ($T_A = 25^\circ\text{C}$)

Fig. 1 $I_{TM}-V_{TM}$ CHARACTERISTICS

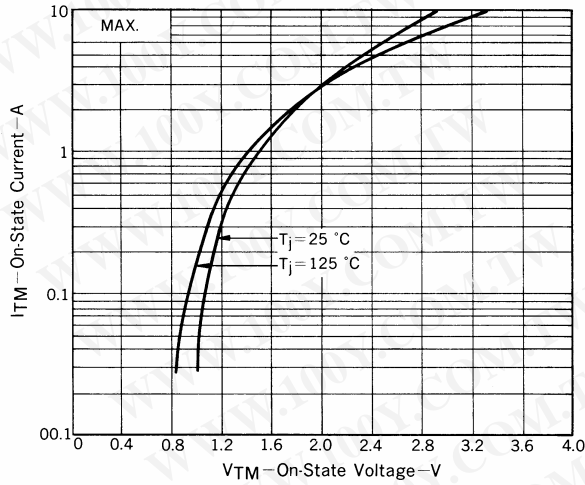

Fig. 2 $P_{T(AV)}-I_{T(AV)}$ CHARACTERISTICS

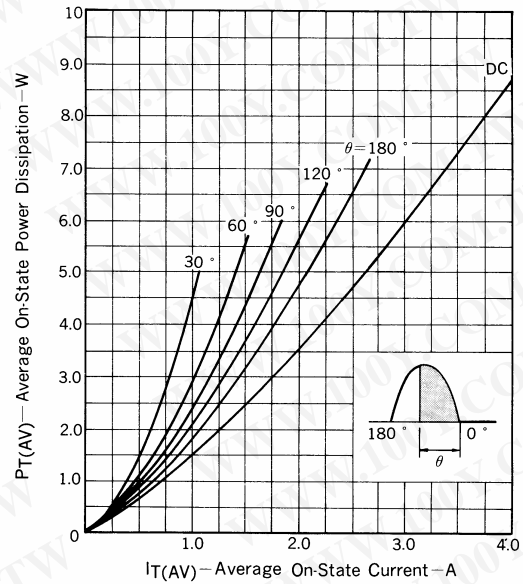

Fig. 3 $I_{T(AV)}-T_C$ RATINGS

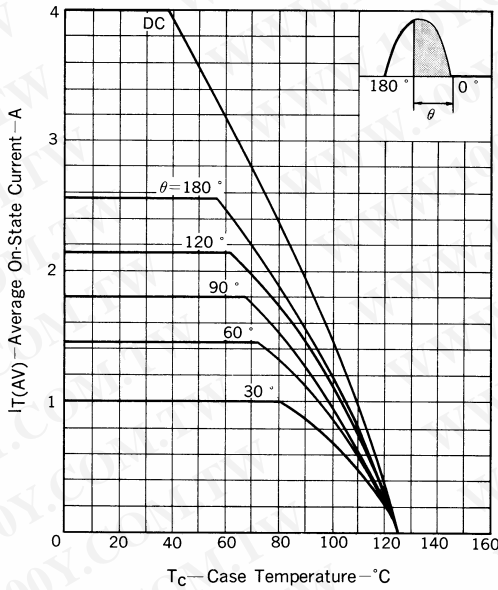

Fig. 4 $T_a-I_{T(AV)}$ RATINGS

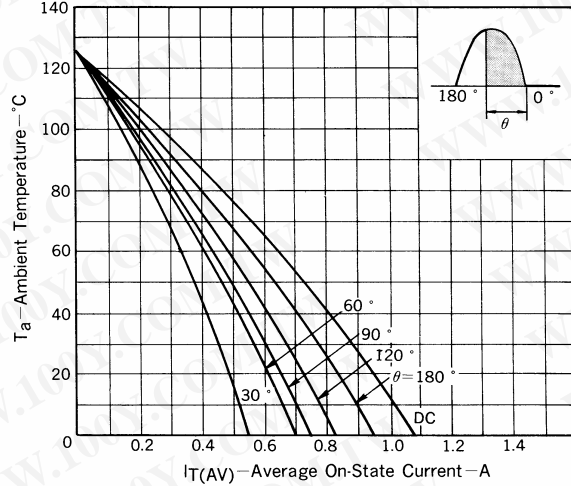

Fig. 5 $I_{GT}-T_a$ TYPICAL DISTRIBUTION

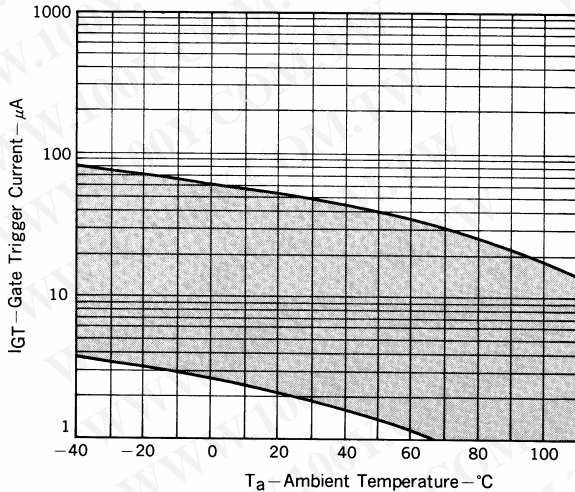

Fig. 6 $V_{GT}-T_a$ TYPICAL DISTRIBUTION

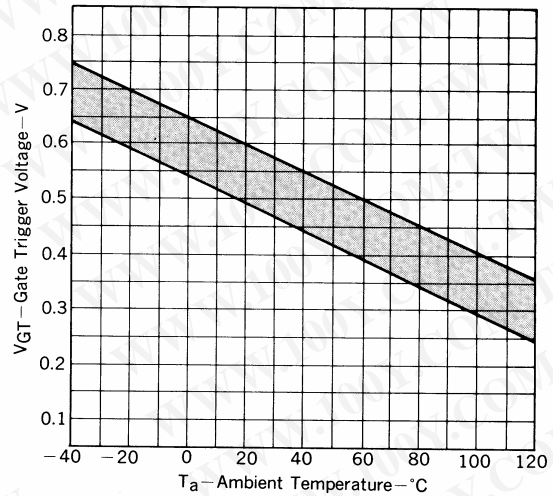

Fig. 7 $I_{GT}-\tau_G$ TYPICAL DISTRIBUTION

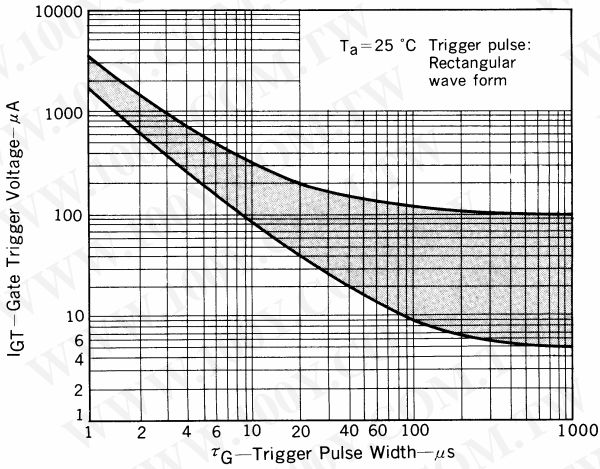

Fig. 8 $V_{GT}-\tau_G$ TYPICAL DISTRIBUTION

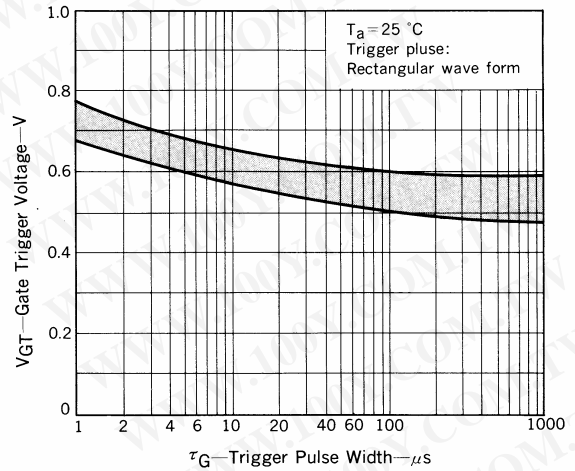

Fig. 9 I_H-T_a TYPICAL DISTRIBUTION

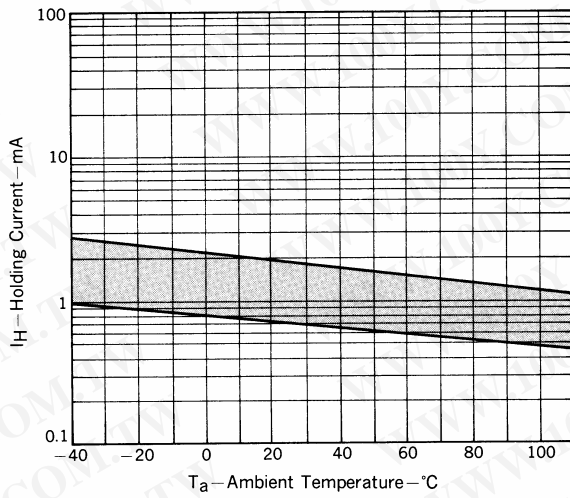

Fig. 10 I_{TSM} RATINGS

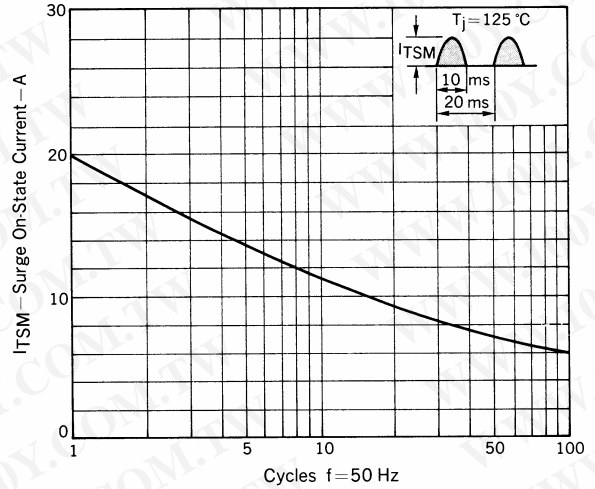
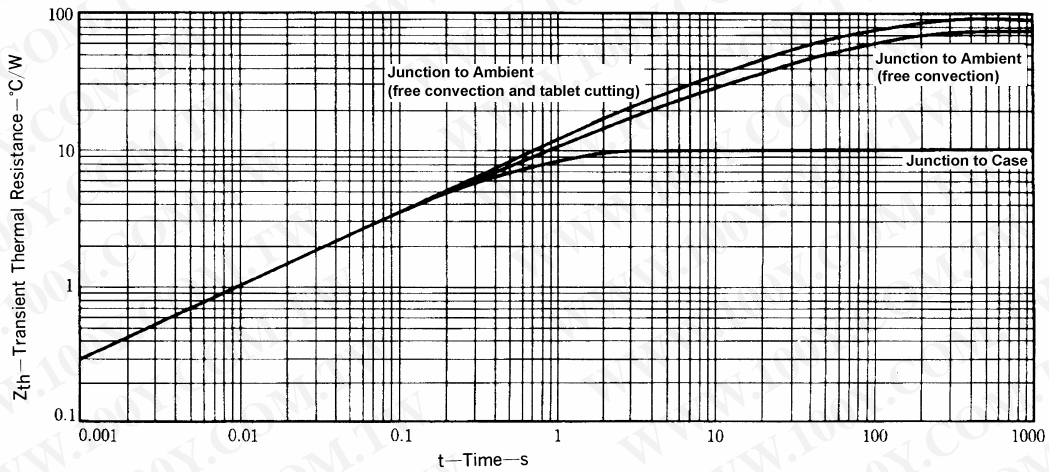

Fig. 11 Z_{th} CHARACTERISTICS



• **The information in this document is current as of July, 2006. The information is subject to change without notice. For actual design-in, refer to the latest publications of NEC Electronics data sheets or data books, etc., for the most up-to-date specifications of NEC Electronics products. Not all products and/or types are available in every country. Please check with an NEC Electronics sales representative for availability and additional information.**

• No part of this document may be copied or reproduced in any form or by any means without the prior written consent of NEC Electronics. NEC Electronics assumes no responsibility for any errors that may appear in this document.

• NEC Electronics does not assume any liability for infringement of patents, copyrights or other intellectual property rights of third parties by or arising from the use of NEC Electronics products listed in this document or any other liability arising from the use of such products. No license, express, implied or otherwise, is granted under any patents, copyrights or other intellectual property rights of NEC Electronics or others.

• Descriptions of circuits, software and other related information in this document are provided for illustrative purposes in semiconductor product operation and application examples. The incorporation of these circuits, software and information in the design of a customer's equipment shall be done under the full responsibility of the customer. NEC Electronics assumes no responsibility for any losses incurred by customers or third parties arising from the use of these circuits, software and information.

• While NEC Electronics endeavors to enhance the quality, reliability and safety of NEC Electronics products, customers agree and acknowledge that the possibility of defects thereof cannot be eliminated entirely. To minimize risks of damage to property or injury (including death) to persons arising from defects in NEC Electronics products, customers must incorporate sufficient safety measures in their design, such as redundancy, fire-containment and anti-failure features.

• NEC Electronics products are classified into the following three quality grades: "Standard", "Special" and "Specific".

The "Specific" quality grade applies only to NEC Electronics products developed based on a customer-designated "quality assurance program" for a specific application. The recommended applications of an NEC Electronics product depend on its quality grade, as indicated below. Customers must check the quality grade of each NEC Electronics product before using it in a particular application.

"Standard": Computers, office equipment, communications equipment, test and measurement equipment, audio and visual equipment, home electronic appliances, machine tools, personal electronic equipment and industrial robots.

"Special": Transportation equipment (automobiles, trains, ships, etc.), traffic control systems, anti-disaster systems, anti-crime systems, safety equipment and medical equipment (not specifically designed for life support).

"Specific": Aircraft, aerospace equipment, submersible repeaters, nuclear reactor control systems, life support systems and medical equipment for life support, etc.

The quality grade of NEC Electronics products is "Standard" unless otherwise expressly specified in NEC Electronics data sheets or data books, etc. If customers wish to use NEC Electronics products in applications not intended by NEC Electronics, they must contact an NEC Electronics sales representative in advance to determine NEC Electronics' willingness to support a given application.

(Note)

(1) "NEC Electronics" as used in this statement means NEC Electronics Corporation and also includes its majority-owned subsidiaries.

(2) "NEC Electronics products" means any product developed or manufactured by or for NEC Electronics (as defined above).