

5A Avg.

65 Volts

SBD

NA05QSA065

■最大定格 Maximum Ratings

Item	Symbol	Conditions	Unit
くり返しピーク逆電圧 Repetitive Peak Reverse Voltage	V_{RRM}	65	V
平均整流電流 Average Rectified Forward Current	I_O	$T_a=27^\circ\text{C}^*$ $V_{RM}=30\text{V}$	1.3
		$T_l=92^\circ\text{C}$ Tl:lead Temperature $V_{RM}=30\text{V}$	5.0
実効順電流 R.M.S. Forward Current	$I_F(\text{RMS})$	7.85	A
サージ順電流 Surge Forward Current	I_{FSM}	100 50Hz正弦半波, 1サイクル, 非くり返し 50Hz Half Sine Wave, 1cycle, Non-repetitive	A
動作接合温度範囲 Operating Junction Temperature Range	T_{jw}	-40~+150	$^\circ\text{C}$
保存温度範囲 Storage Temperature Range	T_{stg}	-40~+150	$^\circ\text{C}$

■OUTLINE DRAWING(mm)

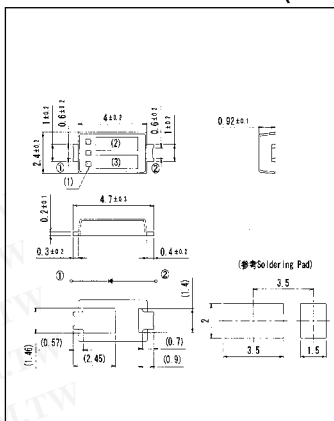

■APPROX. NET WEIGHT:0.03 g

■電氣的・熱的特性 Electrical/Thermal Characteristics

Item	Symbol	Conditions	Min.	Typ.	Max.	Unit
ピーク逆電流 Peak Reverse Current	I_{RM}	$T_j=25^\circ\text{C}$, $V_{RM}=65\text{V}$	—	—	400	μA
ピーク順電圧 Peak Forward Voltage	V_{FM}	$T_j=25^\circ\text{C}$, $I_{FM}=5\text{A}$	—	—	0.61	V
熱抵抗 Thermal Resistance	$R_{th(j-a)}$	接合部・周囲間 Junction to Ambient	—	—	130	$^\circ\text{C}/\text{W}$
	$R_{th(j-l)}$	接合部・リード間 Junction to Lead	—	—	13	$^\circ\text{C}/\text{W}$

*プリント基板実装/Glass-Epoxy Substrate mounted (Soldering Lands= 2.0 × 1.5 mm, 2.0 × 3.5 mm)

■定格・特性曲線

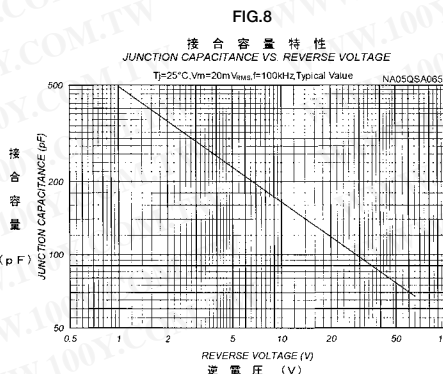
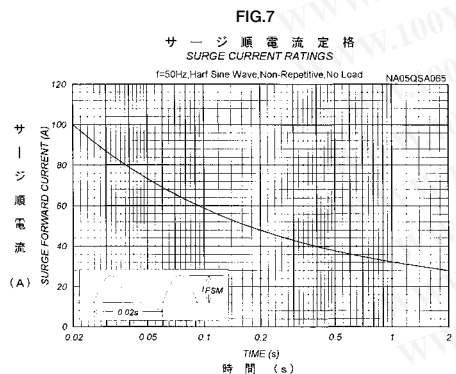
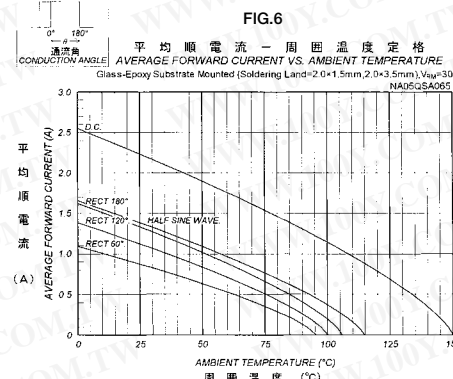
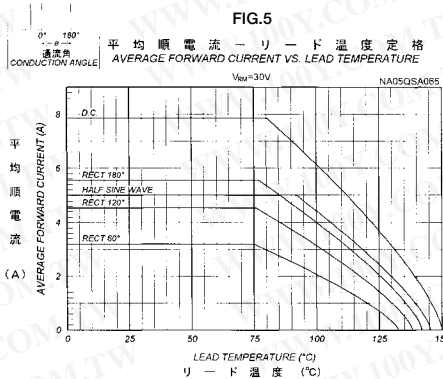
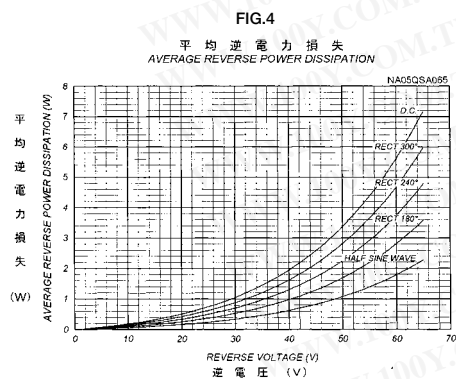
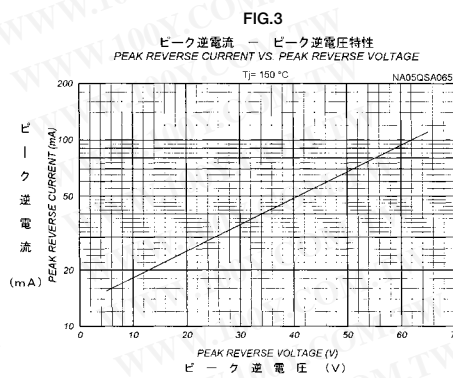
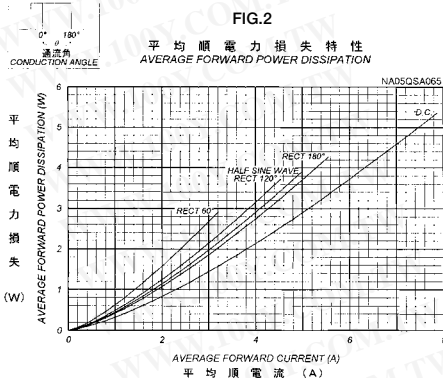
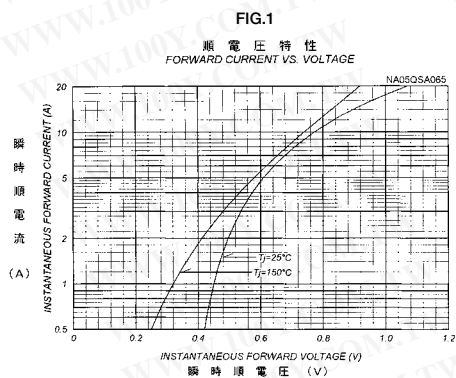

勝特力材料 886-3-5753170
 胜特力电子(上海) 86-21-34970699
 胜特力电子(深圳) 86-755-83298787
[Http://www.100y.com.tw](http://www.100y.com.tw)

日本インターの一般用整流素子は、次表に示す仕様で製品型名などがマークされます。

1. AXIAL LEAD TYPE

適用素子名 Device Type No.	マーキング仕様 Marking
10DDA「」	<p>①カソードマーク Cathode Mark ②略式型名 Type No. Code ③耐圧クラス VRRM Class ④製造年月 Lot No.</p> <p>・10DDA = Silver White Color Code</p>
10JDA「」	<p>①カソードマーク Cathode Mark ②略式型名 Type No. Code ③耐圧クラス VRRM Class ④製造年月 Lot No.</p> <p>・10JDA = Silver White Color Code</p>
10EDA「」 10EDB「」	<p>①カソードマーク Cathode Mark ②略式型名 Type No. Code ③耐圧クラス VRRM Class ④製造年月 Lot No.</p> <p>・10EDA = Silver White Color Code ・10EDB = Blue Color Code</p>
20KDA「」	<p>①カソードマーク Cathode Mark ②略式型名 Type No. Code ③耐圧クラス VRRM Class ④製造年月 Lot No.</p> <p>・20KDA = Silver White Color Code</p>
30PDA「」	<p>①カソードマーク Cathode Mark ②略式型名 Type No. Code ③耐圧クラス VRRM Class ④製造年月 Lot No.</p> <p>・30PDA = Silver White Color Code</p>

2. CHIP TYPE/SOD-123 TYPE

適用素子名 Device Type No.	マーキング仕様 Marking						
EP05DA「」	<p>①カソードマーク Cathode Mark ②略式型名 Type No. Code ③製造年月 Lot No.</p> <p>* 1 ②略式型名 Type No. Code</p> <table border="1"> <tr><td colspan="2">一 般</td></tr> <tr><td>Code</td><td>Type No.</td></tr> <tr><td>U</td><td>EP05DA40</td></tr> </table>	一 般		Code	Type No.	U	EP05DA40
一 般							
Code	Type No.						
U	EP05DA40						

3. CHIP TYPE/SMA TYPE

適用素子名 Device Type No.	マーキング仕様 Marking												
EC10DS「」 EC10DA「」	<p>①カソードマーク Cathode Mark ②略式型名 Type No. Code ③製造年月 Lot No.</p> <p>* 1 ②略式型名 Type No. Code</p> <table border="1"> <tr><td colspan="2">一 般</td></tr> <tr><td>Code</td><td>Type No.</td></tr> <tr><td>D1</td><td>EC10DS1</td></tr> <tr><td>D2</td><td>EC10DS2</td></tr> <tr><td>D4</td><td>EC10DS4</td></tr> <tr><td>A4</td><td>EC10DA40</td></tr> </table>	一 般		Code	Type No.	D1	EC10DS1	D2	EC10DS2	D4	EC10DS4	A4	EC10DA40
一 般													
Code	Type No.												
D1	EC10DS1												
D2	EC10DS2												
D4	EC10DS4												
A4	EC10DA40												

4. CHIP TYPE/Narrow SMC TYPE

適用素子名 Device Type No.	マーキング仕様 Marking										
NSD03A「」	<p>①カソードマーク Cathode Mark ②電流値クラス Io Class ③略式型名 Type No. Code ④製造年月 Lot No.</p> <p>* 1 ③略式型名 Type No. Code</p> <table border="1"> <tr><td colspan="2">一 般</td></tr> <tr><td>Code</td><td>Type No.</td></tr> <tr><td>D1</td><td>NSD03A10</td></tr> <tr><td>D2</td><td>NSD03A20</td></tr> <tr><td>D4</td><td>NSD03A40</td></tr> </table>	一 般		Code	Type No.	D1	NSD03A10	D2	NSD03A20	D4	NSD03A40
一 般											
Code	Type No.										
D1	NSD03A10										
D2	NSD03A20										
D4	NSD03A40										

勝特力材料 886-3-5753170
胜特力电子(上海) 86-21-34970699
胜特力电子(深圳) 86-755-83298787
[Http://www.100y.com.tw](http://www.100y.com.tw)

マーキング仕様

勝特力材料 886-3-5753170
 勝特力電子(上海) 86-21-34970699
 勝特力電子(深圳) 86-755-83298787
[Http://www.100y.com.tw](http://www.100y.com.tw)

日本インターのSBDおよびFREDは、次表に示す仕様で製品型名などがマークされます。

1. AXIAL LEAD TYPE

適用素子名 Device Type No.	マーキング仕様 Marking	適用素子名 Device Type No.	マーキング仕様 Marking
11EQS「JL」 11EQS「」 11EFS「」	<p>①カソードマーク Cathode Mark ②耐圧クラス V_{RRM} Class ③略式型名 Type No. ④製造月 Lot No.</p> <p>・11EQS = Green Color Code ・11EFS = Blue Color Code ・10EQMA = White Color Code</p>	30PHA「」	<p>①カソードマーク Cathode Mark ②略式型名 Type No. ③耐圧クラス V_{RRM} Class ④製造年月 Lot No.</p> <p>・30PHA = Silver White Color Code</p>
11EQ「」	<p>①カソードマーク Cathode Mark ②製造年月 Lot No. ③略式型名 Type No. ④耐圧クラス V_{RRM} Class</p> <p>・11EQ = Silver White Color Code</p>	10ERA「」 10ERB「」	<p>①カソードマーク Cathode Mark ②略式型名 Type No. ③耐圧クラス V_{RRM} Class ④製造年月 Lot No.</p> <p>・10ERA = Silver White Color Code ・10ERB = Red Color Code</p>
11DQ「」	<p>①カソードマーク Cathode Mark ②略式型名 Type No. ③耐圧クラス V_{RRM} Class ④製造年月 Lot No.</p> <p>・11DQ = Silver White Color Code</p>	10DRA「」	<p>①カソードマーク Cathode Mark ②略式型名 Type No. ③耐圧クラス V_{RRM} Class ④製造年月 Lot No.</p> <p>・10DRA = Silver White Color Code</p>
10EHA「」	<p>①カソードマーク Cathode Mark ②略式型名 Type No. ③耐圧クラス (D:200V) V_{RRM} Class ④製造年月 Lot No.</p> <p>・10EHA = Green Color Code</p>	15KRA「」	<p>①カソードマーク Cathode Mark ②略式型名 Type No. ③耐圧クラス V_{RRM} Class ④製造年月 Lot No.</p> <p>・15KRA = Silver White Color Code</p>
21DQ「JL」 21DQ「」	<p>①カソードマーク Cathode Mark ②製造年月 Lot No. ③略式型名 Type No. ④耐圧クラス V_{RRM} Class 21DQ03L→3L</p> <p>・21DQ = Silver White Color Code</p>	20NFA「」 20NFB「」	<p>①カソードマーク Cathode Mark ②製造年月 Lot No. ③略式型名 Type No. ④耐圧クラス V_{RRM} Class</p> <p>・20NFA = Silver White Color Code</p>
20KHA「」	<p>①カソードマーク Cathode Mark ②略式型名 Type No. ③耐圧クラス V_{RRM} Class ④製造年月 Lot No.</p> <p>・20KHA = Silver White Color Code</p>	11DF「」	<p>①カソードマーク Cathode Mark ②略式型名 Type No. ③耐圧クラス V_{RRM} Class ④製造年月 Lot No.</p> <p>・11DF = Silver White Color Code</p>
31DQ「JL」 31DQ「」 50PHSA「」 5PQS「」	<p>①カソードマーク Cathode Mark ②略式型名 Type No. ③耐圧クラス V_{RRM} Class 31DQ03L→3L ④製造年月 Lot No.</p> <p>・31DQ = Silver White Color Code</p>	31DF「」	<p>①カソードマーク Cathode Mark ②略式型名 Type No. ③製造年月 Lot No. ④耐圧クラス V_{RRM} Class</p> <p>・31DF = Silver White Color Code</p>

Continued on the following page.

Continued from the preceding page

1. AXIAL LEAD TYPE

適用素子名 Device Type No.	マーキング仕様 Marking
30PFB「」	<p>①カソードマーク Cathode Mark ②略式型名 Type No. ③耐圧クラス VRRM Class ④製造年月 Lot No.</p> <p>・30PFB = Silver White Color Code</p>
30PFD「」	<p>①カソードマーク Cathode Mark ②略式型名 Type No. ③耐圧クラス VRRM Class ④製造年月 Lot No.</p> <p>・30PFD = Silver White Color Code</p>
30PUA「」	<p>①カソードマーク Cathode Mark ②略式型名 Type No. ③耐圧クラス VRRM Class ④製造年月 Lot No.</p> <p>・30PUA = Silver White Color Code</p>
30PUB「」	<p>①カソードマーク Cathode Mark ②略式型名 Type No. ③耐圧クラス VRRM Class ④製造年月 Lot No.</p> <p>・30PUB = Silver White Color Code</p>
30PRA「」	<p>①カソードマーク Cathode Mark ②略式型名 Type No. ③耐圧クラス VRRM Class ④製造年月 Lot No.</p> <p>・30PRA = Silver White Color Code</p>

2. CHIP TYPE/SOD-323 FL TYPE

適用素子名 Device Type No.	マーキング仕様 Marking						
SA10LA「」 SA10QA「」	<p>①カソードマーク Cathode Mark ②略式型名 Type No. Code ③製造年月 Lot No.</p> <table border="1"> <thead> <tr> <th>Code</th> <th>Type No.</th> </tr> </thead> <tbody> <tr> <td>A</td> <td>SA10QA03</td> </tr> <tr> <td>B</td> <td>SA10LA03</td> </tr> </tbody> </table>	Code	Type No.	A	SA10QA03	B	SA10LA03
Code	Type No.						
A	SA10QA03						
B	SA10LA03						

3. CHIP TYPE/SOD-123 TYPE

適用素子名 Device Type No.	マーキング仕様 Marking																						
EP05Q「」L EP05Q「」 EP05H「」 EP10LA「」 EP10QY「」 EP05FA「」 EP10HY「」	<p>①カソードマーク Cathode Mark * 1 ②略式型名 Type No. ③製造年月 Lot No.</p> <p>* 1 ②略式型名 Type No. Code</p> <table border="1"> <thead> <tr> <th colspan="2">SBD/FRD</th> </tr> <tr> <th>Code</th> <th>Type No.</th> </tr> </thead> <tbody> <tr> <td>H</td> <td>EP05Q03L</td> </tr> <tr> <td>A</td> <td>EP05Q04</td> </tr> <tr> <td>B</td> <td>EP05Q06</td> </tr> <tr> <td>E</td> <td>EP05H10</td> </tr> <tr> <td>Z</td> <td>EP10LA03</td> </tr> <tr> <td>Y</td> <td>EP10QY03</td> </tr> <tr> <td>N</td> <td>EP05FA20</td> </tr> <tr> <td>8</td> <td>EP10QY04</td> </tr> <tr> <td>J</td> <td>EP10HY03</td> </tr> </tbody> </table>	SBD/FRD		Code	Type No.	H	EP05Q03L	A	EP05Q04	B	EP05Q06	E	EP05H10	Z	EP10LA03	Y	EP10QY03	N	EP05FA20	8	EP10QY04	J	EP10HY03
SBD/FRD																							
Code	Type No.																						
H	EP05Q03L																						
A	EP05Q04																						
B	EP05Q06																						
E	EP05H10																						
Z	EP10LA03																						
Y	EP10QY03																						
N	EP05FA20																						
8	EP10QY04																						
J	EP10HY03																						

4. CHIP TYPE NA・NB

適用素子名 Device Type No.	マーキング仕様 Marking												
NA03QSA「」 NA03HSA「」	<p>①カソードマーク Cathode Mark ②略式型名 Type No. Code ③製造年月 Lot No.</p> <p>②型名略コード Type Code</p> <table border="1"> <thead> <tr> <th>Code</th> <th>Type No.</th> <th>Code</th> <th>Type No.</th> </tr> </thead> <tbody> <tr> <td>HA6</td> <td>NA03HSA065</td> <td>QA4</td> <td>NA03QSA045</td> </tr> <tr> <td>HAB</td> <td>NA03HSA12</td> <td>QA6</td> <td>NA03QSA065</td> </tr> </tbody> </table>	Code	Type No.	Code	Type No.	HA6	NA03HSA065	QA4	NA03QSA045	HAB	NA03HSA12	QA6	NA03QSA065
Code	Type No.	Code	Type No.										
HA6	NA03HSA065	QA4	NA03QSA045										
HAB	NA03HSA12	QA6	NA03QSA065										
NB05QSA「」 NA05HSA「」	<p>①カソードマーク Cathode Mark ②略式型名 Type No. Code ③製造年月 Lot No.</p> <p>②型名略コード Type Code</p> <table border="1"> <thead> <tr> <th>Code</th> <th>Type No.</th> <th>Code</th> <th>Type No.</th> </tr> </thead> <tbody> <tr> <td>HA6</td> <td>NA05HSA065</td> <td>QA4</td> <td>NA05QSA045</td> </tr> <tr> <td>HAB</td> <td>NA05HSA12</td> <td>QA6</td> <td>NA05QSA065</td> </tr> </tbody> </table>	Code	Type No.	Code	Type No.	HA6	NA05HSA065	QA4	NA05QSA045	HAB	NA05HSA12	QA6	NA05QSA065
Code	Type No.	Code	Type No.										
HA6	NA05HSA065	QA4	NA05QSA045										
HAB	NA05HSA12	QA6	NA05QSA065										
NB06QSA「」 NB06HSA「」	<p>①カソードマーク Cathode Mark ②略式型名 Type No. Code ③製造年月 Lot No.</p> <p>②型名略コード Type Code</p> <table border="1"> <thead> <tr> <th>Code</th> <th>Type No.</th> <th>Code</th> <th>Type No.</th> </tr> </thead> <tbody> <tr> <td>06HA6</td> <td>NB06HSA065</td> <td>06QA4</td> <td>NB06QSA045</td> </tr> <tr> <td>06HAB</td> <td>NB06HSA12</td> <td>06QA6</td> <td>NB06QSA065</td> </tr> </tbody> </table>	Code	Type No.	Code	Type No.	06HA6	NB06HSA065	06QA4	NB06QSA045	06HAB	NB06HSA12	06QA6	NB06QSA065
Code	Type No.	Code	Type No.										
06HA6	NB06HSA065	06QA4	NB06QSA045										
06HAB	NB06HSA12	06QA6	NB06QSA065										
NB10QSA「」 NB10HSA「」	<p>①カソードマーク Cathode Mark ②略式型名 Type No. Code ③製造年月 Lot No.</p> <p>②型名略コード Type Code</p> <table border="1"> <thead> <tr> <th>Code</th> <th>Type No.</th> <th>Code</th> <th>Type No.</th> </tr> </thead> <tbody> <tr> <td>10HA6</td> <td>NB10HSA065</td> <td>10QA4</td> <td>NB10QSA045</td> </tr> <tr> <td>10HAB</td> <td>NB10HSA12</td> <td>10QA6</td> <td>NB10QSA065</td> </tr> </tbody> </table>	Code	Type No.	Code	Type No.	10HA6	NB10HSA065	10QA4	NB10QSA045	10HAB	NB10HSA12	10QA6	NB10QSA065
Code	Type No.	Code	Type No.										
10HA6	NB10HSA065	10QA4	NB10QSA045										
10HAB	NB10HSA12	10QA6	NB10QSA065										

勝特力材料 886-3-5753170
胜特力电子(上海) 86-21-34970699
胜特力电子(深圳) 86-755-83298787
[Http://www.100y.com.tw](http://www.100y.com.tw)

マーキング仕様

Continued from the preceding page

5. CHIP TYPE/SMA TYPE

適用素子名 Device Type No.	マーキング仕様 Marking																																								
EC10QS「J」L EC10QS「J」 EC8FS「J」 EC11FS「J」 EC10LA「J」 EC10UA「J」	<p>①カソードマーク Cathode Mark * 1 ②略式型名 Type No. ③製造年月 Lot No.</p> <p>* 1 ②略式型名 Type No. Code</p> <table border="1"> <thead> <tr> <th colspan="2">SBD</th> <th colspan="2">FRD</th> </tr> <tr> <th>Code</th> <th>Type No.</th> <th>Code</th> <th>Type No.</th> </tr> </thead> <tbody> <tr> <td>S3</td> <td>EC10QS03L</td> <td>F2</td> <td>EC11FS2</td> </tr> <tr> <td>S4</td> <td>EC10QS04</td> <td>F4</td> <td>EC11FS4</td> </tr> <tr> <td>S6</td> <td>EC10QS06</td> <td>F6</td> <td>EC8FS6</td> </tr> <tr> <td>S9</td> <td>EC10QS09</td> <td>M1</td> <td>EC10UA20</td> </tr> <tr> <td>S0</td> <td>EC10QS10</td> <td>M2</td> <td>EC10UA40</td> </tr> <tr> <td>L3</td> <td>EC10LA03</td> <td></td> <td></td> </tr> </tbody> </table>	SBD		FRD		Code	Type No.	Code	Type No.	S3	EC10QS03L	F2	EC11FS2	S4	EC10QS04	F4	EC11FS4	S6	EC10QS06	F6	EC8FS6	S9	EC10QS09	M1	EC10UA20	S0	EC10QS10	M2	EC10UA40	L3	EC10LA03										
SBD		FRD																																							
Code	Type No.	Code	Type No.																																						
S3	EC10QS03L	F2	EC11FS2																																						
S4	EC10QS04	F4	EC11FS4																																						
S6	EC10QS06	F6	EC8FS6																																						
S9	EC10QS09	M1	EC10UA20																																						
S0	EC10QS10	M2	EC10UA40																																						
L3	EC10LA03																																								
EC20QSA「J」 EC21QS「J」L EC21QS「J」 EC30LA「J」	<p>①カソードマーク Cathode Mark * 1 ②略式型名 Type No. ③製造年月 Lot No. ④生産拠点コード Production base code 「blank」 or 「●」</p> <p>* 1 ②略式型名 Type No. Code</p> <table border="1"> <thead> <tr> <th colspan="2">SBD</th> <th colspan="2">SBD</th> </tr> <tr> <th>Code</th> <th>Type No.</th> <th>Code</th> <th>Type No.</th> </tr> </thead> <tbody> <tr> <td>P3</td> <td>EC20QSA035</td> <td>T1</td> <td>EC21QS03L</td> </tr> <tr> <td>P4</td> <td>EC20QSA045</td> <td>T2</td> <td>EC21QS04</td> </tr> <tr> <td>P6</td> <td>EC20QSA065</td> <td>T3</td> <td>EC21QS06</td> </tr> <tr> <td></td> <td></td> <td>T4</td> <td>EC21QS09</td> </tr> <tr> <td></td> <td></td> <td>T5</td> <td>EC21QS10</td> </tr> <tr> <td></td> <td></td> <td>U2</td> <td>EC30LA02</td> </tr> </tbody> </table>	SBD		SBD		Code	Type No.	Code	Type No.	P3	EC20QSA035	T1	EC21QS03L	P4	EC20QSA045	T2	EC21QS04	P6	EC20QSA065	T3	EC21QS06			T4	EC21QS09			T5	EC21QS10			U2	EC30LA02								
SBD		SBD																																							
Code	Type No.	Code	Type No.																																						
P3	EC20QSA035	T1	EC21QS03L																																						
P4	EC20QSA045	T2	EC21QS04																																						
P6	EC20QSA065	T3	EC21QS06																																						
		T4	EC21QS09																																						
		T5	EC21QS10																																						
		U2	EC30LA02																																						
EC30QSA「J」 EC31QS「J」L EC31QS「J」 EC30LB「J」 EC30HA「J」	<p>①カソードマーク Cathode Mark * 1 ②略式型名 Type No. ③製造年月 Lot No. ④生産拠点コード Production base code 「blank」 or 「●」</p> <p>* 1 ②略式型名 Type No. Code</p> <table border="1"> <thead> <tr> <th colspan="2">SBD</th> <th colspan="2">SBD</th> </tr> <tr> <th>Code</th> <th>Type No.</th> <th>Code</th> <th>Type No.</th> </tr> </thead> <tbody> <tr> <td>P3</td> <td>EC30QSA035</td> <td>L2</td> <td>EC30LB02</td> </tr> <tr> <td>P4</td> <td>EC30QSA045</td> <td>H3</td> <td>EC30HA03L</td> </tr> <tr> <td>P6</td> <td>EC30QSA065</td> <td>H4</td> <td>EC30HA04</td> </tr> <tr> <td>T1</td> <td>EC31QS03L</td> <td></td> <td></td> </tr> <tr> <td>T2</td> <td>EC31QS04</td> <td></td> <td></td> </tr> <tr> <td>T3</td> <td>EC31QS06</td> <td></td> <td></td> </tr> <tr> <td>T4</td> <td>EC31QS09</td> <td></td> <td></td> </tr> <tr> <td>T5</td> <td>EC31QS10</td> <td></td> <td></td> </tr> </tbody> </table>	SBD		SBD		Code	Type No.	Code	Type No.	P3	EC30QSA035	L2	EC30LB02	P4	EC30QSA045	H3	EC30HA03L	P6	EC30QSA065	H4	EC30HA04	T1	EC31QS03L			T2	EC31QS04			T3	EC31QS06			T4	EC31QS09			T5	EC31QS10		
SBD		SBD																																							
Code	Type No.	Code	Type No.																																						
P3	EC30QSA035	L2	EC30LB02																																						
P4	EC30QSA045	H3	EC30HA03L																																						
P6	EC30QSA065	H4	EC30HA04																																						
T1	EC31QS03L																																								
T2	EC31QS04																																								
T3	EC31QS06																																								
T4	EC31QS09																																								
T5	EC31QS10																																								

6. CHIP TYPE/Narrow SMC TYPE

適用素子名 Device Type No.	マーキング仕様 Marking																																				
NSQ03A「J」L NSQ03A「J」 NSH03A「J」 NSF03A「J」 NSU03A「J」 NSU03B「J」 NSF03B「J」 NSF03D「J」 NSF03E「J」	<p>①カソードマーク Cathode Mark ②電流値クラス Io Class * 1 ③, ④略式型名 Type No. ⑤製造年月 Lot No.</p> <p>* 1 ③, ④略式型名 Type No. Code</p> <table border="1"> <thead> <tr> <th colspan="2">SBD</th> <th colspan="2">FRD</th> </tr> <tr> <th>Code</th> <th>Type No.</th> <th>Code</th> <th>Type No.</th> </tr> </thead> <tbody> <tr> <td>A S3</td> <td>NSQ03A03L</td> <td>A F2</td> <td>NSF03A20</td> </tr> <tr> <td>A S4</td> <td>NSQ03A04</td> <td>A F4</td> <td>NSF03A40</td> </tr> <tr> <td>A S6</td> <td>NSQ03A06</td> <td>A F6</td> <td>NSF03A60</td> </tr> <tr> <td>A H3</td> <td>NSH03A03L</td> <td>A U6</td> <td>NSU03A60</td> </tr> <tr> <td>A H4</td> <td>NSH03A04</td> <td>B U6</td> <td>NSU03B60</td> </tr> <tr> <td>A H9</td> <td>NSH03A09</td> <td>D F6</td> <td>NSF03D60</td> </tr> <tr> <td>A H0</td> <td>NSH03A10</td> <td>E F6</td> <td>NSF03E60</td> </tr> </tbody> </table>	SBD		FRD		Code	Type No.	Code	Type No.	A S3	NSQ03A03L	A F2	NSF03A20	A S4	NSQ03A04	A F4	NSF03A40	A S6	NSQ03A06	A F6	NSF03A60	A H3	NSH03A03L	A U6	NSU03A60	A H4	NSH03A04	B U6	NSU03B60	A H9	NSH03A09	D F6	NSF03D60	A H0	NSH03A10	E F6	NSF03E60
SBD		FRD																																			
Code	Type No.	Code	Type No.																																		
A S3	NSQ03A03L	A F2	NSF03A20																																		
A S4	NSQ03A04	A F4	NSF03A40																																		
A S6	NSQ03A06	A F6	NSF03A60																																		
A H3	NSH03A03L	A U6	NSU03A60																																		
A H4	NSH03A04	B U6	NSU03B60																																		
A H9	NSH03A09	D F6	NSF03D60																																		
A H0	NSH03A10	E F6	NSF03E60																																		

7. SIMILAR TO TO-251/TO-252 TYPE

適用素子名 Device Type No.	マーキング仕様 Marking																																																												
(Single Chip) EA20QS「J」 EA20QS「J」-F EA30QS「J」 EA30QS「J」-F ESL03B「J」 ESL03B「J」-F EA31FS「J」 EA31FS「J」-F EA30QS「J」L EA30QS「J」L-F ESH05A「J」 ESH05A「J」-F ESU03A「J」 ESU03A「J」-F ESF03B「J」 ESF03B「J」-F	<p>①社名略マーク (N) Manufacturer's Mark(N) ②製造年月 Lot No. * 1 ③略式型名 Type No.</p> <p>(-F type)</p>																																																												
(Center Tap) EA20QC「J」 EA20QC「J」-F EA40QC「J」 EA40QC「J」-F EA60QC「J」L EA60QC「J」L-F EA60QC「J」 EA60QC「J」-F ECL06B「J」 ECL06B「J」-F EA21FC「J」 EA21FC「J」-F EA61FC「J」 EA61FC「J」-F ECQ10A「J」L ECQ10A「J」L-F ECQ10A「J」 ECQ10A「J」-F ECH06A「J」 ECH06A「J」-F ESU03A「J」(-F) ESU03A「J」(-F)	<p>* 1 ③略式型名 Type No.</p> <table border="1"> <thead> <tr> <th colspan="2">Single Chip</th> <th colspan="2">Center Tap</th> </tr> <tr> <th>Type No.</th> <th>Marked as</th> <th>Type No.</th> <th>Marked as</th> </tr> </thead> <tbody> <tr> <td>EA20QS「J」(-F)</td> <td>20Q「J」</td> <td>EA20QC「J」(-F)</td> <td>20QC「J」</td> </tr> <tr> <td>EA30QS「J」(-F)</td> <td>30Q「J」</td> <td>EA40QC「J」(-F)</td> <td>40QC「J」</td> </tr> <tr> <td>ESL03B03(-F)</td> <td>SL3B030</td> <td>EA60QC「J」L(-F)</td> <td>60QC「J」L</td> </tr> <tr> <td>EA31FS「J」(-F)</td> <td>31F「J」</td> <td>EA60QC「J」(-F)</td> <td>60QC「J」</td> </tr> <tr> <td>EA30QS「J」L(-F)</td> <td>30Q「J」L</td> <td>ECL06B03(-F)</td> <td>CL6B030</td> </tr> <tr> <td>ESH05A「J」(-F)</td> <td>SH5A「J」</td> <td>EA21FC「J」(-F)</td> <td>21FC「J」</td> </tr> <tr> <td>ESL03B025(-F)</td> <td>SL3B025</td> <td>EA61FC「J」(-F)</td> <td>61FC「J」</td> </tr> <tr> <td>ESU03A「J」(-F)</td> <td>SU3A「J」</td> <td>ECL06B025(-F)</td> <td>CL6B025</td> </tr> <tr> <td>ECU06A「J」</td> <td></td> <td>ECQ10A「J」L(-F)</td> <td>CQ10A「J」L</td> </tr> <tr> <td>ECU06A「J」-F</td> <td></td> <td>ECQ10A「J」(-F)</td> <td>CQ10A「J」</td> </tr> <tr> <td>ECU06B「J」</td> <td></td> <td>ECH06A「J」(-F)</td> <td>CH6A「J」</td> </tr> <tr> <td>ECU06B「J」-F</td> <td></td> <td>ECU06A「J」(-F)</td> <td>CU6A「J」</td> </tr> <tr> <td>ECF06B「J」</td> <td></td> <td>ECU06B「J」(-F)</td> <td>CU6B「J」</td> </tr> </tbody> </table>	Single Chip		Center Tap		Type No.	Marked as	Type No.	Marked as	EA20QS「J」(-F)	20Q「J」	EA20QC「J」(-F)	20QC「J」	EA30QS「J」(-F)	30Q「J」	EA40QC「J」(-F)	40QC「J」	ESL03B03(-F)	SL3B030	EA60QC「J」L(-F)	60QC「J」L	EA31FS「J」(-F)	31F「J」	EA60QC「J」(-F)	60QC「J」	EA30QS「J」L(-F)	30Q「J」L	ECL06B03(-F)	CL6B030	ESH05A「J」(-F)	SH5A「J」	EA21FC「J」(-F)	21FC「J」	ESL03B025(-F)	SL3B025	EA61FC「J」(-F)	61FC「J」	ESU03A「J」(-F)	SU3A「J」	ECL06B025(-F)	CL6B025	ECU06A「J」		ECQ10A「J」L(-F)	CQ10A「J」L	ECU06A「J」-F		ECQ10A「J」(-F)	CQ10A「J」	ECU06B「J」		ECH06A「J」(-F)	CH6A「J」	ECU06B「J」-F		ECU06A「J」(-F)	CU6A「J」	ECF06B「J」		ECU06B「J」(-F)	CU6B「J」
Single Chip		Center Tap																																																											
Type No.	Marked as	Type No.	Marked as																																																										
EA20QS「J」(-F)	20Q「J」	EA20QC「J」(-F)	20QC「J」																																																										
EA30QS「J」(-F)	30Q「J」	EA40QC「J」(-F)	40QC「J」																																																										
ESL03B03(-F)	SL3B030	EA60QC「J」L(-F)	60QC「J」L																																																										
EA31FS「J」(-F)	31F「J」	EA60QC「J」(-F)	60QC「J」																																																										
EA30QS「J」L(-F)	30Q「J」L	ECL06B03(-F)	CL6B030																																																										
ESH05A「J」(-F)	SH5A「J」	EA21FC「J」(-F)	21FC「J」																																																										
ESL03B025(-F)	SL3B025	EA61FC「J」(-F)	61FC「J」																																																										
ESU03A「J」(-F)	SU3A「J」	ECL06B025(-F)	CL6B025																																																										
ECU06A「J」		ECQ10A「J」L(-F)	CQ10A「J」L																																																										
ECU06A「J」-F		ECQ10A「J」(-F)	CQ10A「J」																																																										
ECU06B「J」		ECH06A「J」(-F)	CH6A「J」																																																										
ECU06B「J」-F		ECU06A「J」(-F)	CU6A「J」																																																										
ECF06B「J」		ECU06B「J」(-F)	CU6B「J」																																																										

勝特力材料 886-3-5753170
 勝特力電子(上海) 86-21-34970699
 勝特力電子(深圳) 86-755-83298787
[Http://www.100y.com.tw](http://www.100y.com.tw)

Continued from the preceding page

8. SIMILAR TO TO-263 TYPE

適用素子名 Device Type No.	マーキング仕様 Marking																														
C10T「」Q C10T「」QH C10T「」QL C10T「」QLH C20T「」Q C20T「」QH C20T「」QL C20T「」QLH C30T「」Q C30T「」QH C30T「」QL C30T「」QLH C10T「」F C16T「」F TSU05A「」 TCH10A「」 TCH20A「」 TCH30A「」 TCH30C「」 TSF05B「」 TCF20B「」 TCF10B「」 UCQS30A「」 UCHS30A「」 UCQ10A「」 UCQ20B「」 UCU20C「」 (-11A type)	<p>①社名略マーク (N) Manufacturer's Mark(N)</p> <p>②製造年月 Lot No.</p> <p>③略式型名 Type No.</p> <p>④極性 Polarity Mark</p> <p>(-11A type)</p> <p>(Single type)</p>																														
	* 1 ③略式型名 Type No.																														
	<table border="1"> <thead> <tr> <th>Type No.</th> <th>Marked as</th> </tr> </thead> <tbody> <tr> <td>C10T「」(Q,QH,QL,QLH,F)</td> <td rowspan="2">C10T「」(Q,QH,QL,QLH,F)</td> </tr> <tr> <td>C10T「」(Q,QH,QL,QLH,F)-11A</td> </tr> <tr> <td>C20T「」(Q,QH,QL,QLH)</td> <td rowspan="2">C20T「」(Q,QH,QL,QLH)</td> </tr> <tr> <td>C20T「」(Q,QH,QL,QLH)-11A</td> </tr> <tr> <td>C30T「」(Q,QH,QL,QLH)</td> <td rowspan="2">C30T「」(Q,QH,QL,QLH)</td> </tr> <tr> <td>C30T「」(Q,QH,QL,QLH)-11A</td> </tr> <tr> <td>C16T「」F</td> <td rowspan="2">C16T「」F</td> </tr> <tr> <td>C16T「」F-11A</td> </tr> <tr> <td>TSU05A「」</td> <td>TSU05A「」</td> </tr> <tr> <td>TSU05B「」</td> <td>TSU05B「」</td> </tr> <tr> <td>TSU10A「」</td> <td>TSU10A「」</td> </tr> <tr> <td>TSU10B「」</td> <td>TSU10B「」</td> </tr> <tr> <td>TCH10A「」, TCH10A「」-11A</td> <td>TCH10A「」</td> </tr> <tr> <td>TCH20A「」, TCH20A「」-11A</td> <td>TCH20A「」</td> </tr> <tr> <td>TCH30A「」, TCH30A「」-11A</td> <td>TCH30A「」</td> </tr> <tr> <td>TCH30C「」</td> <td>TCH30C「」</td> </tr> </tbody> </table>	Type No.	Marked as	C10T「」(Q,QH,QL,QLH,F)	C10T「」(Q,QH,QL,QLH,F)	C10T「」(Q,QH,QL,QLH,F)-11A	C20T「」(Q,QH,QL,QLH)	C20T「」(Q,QH,QL,QLH)	C20T「」(Q,QH,QL,QLH)-11A	C30T「」(Q,QH,QL,QLH)	C30T「」(Q,QH,QL,QLH)	C30T「」(Q,QH,QL,QLH)-11A	C16T「」F	C16T「」F	C16T「」F-11A	TSU05A「」	TSU05A「」	TSU05B「」	TSU05B「」	TSU10A「」	TSU10A「」	TSU10B「」	TSU10B「」	TCH10A「」, TCH10A「」-11A	TCH10A「」	TCH20A「」, TCH20A「」-11A	TCH20A「」	TCH30A「」, TCH30A「」-11A	TCH30A「」	TCH30C「」	TCH30C「」
Type No.	Marked as																														
C10T「」(Q,QH,QL,QLH,F)	C10T「」(Q,QH,QL,QLH,F)																														
C10T「」(Q,QH,QL,QLH,F)-11A																															
C20T「」(Q,QH,QL,QLH)	C20T「」(Q,QH,QL,QLH)																														
C20T「」(Q,QH,QL,QLH)-11A																															
C30T「」(Q,QH,QL,QLH)	C30T「」(Q,QH,QL,QLH)																														
C30T「」(Q,QH,QL,QLH)-11A																															
C16T「」F	C16T「」F																														
C16T「」F-11A																															
TSU05A「」	TSU05A「」																														
TSU05B「」	TSU05B「」																														
TSU10A「」	TSU10A「」																														
TSU10B「」	TSU10B「」																														
TCH10A「」, TCH10A「」-11A	TCH10A「」																														
TCH20A「」, TCH20A「」-11A	TCH20A「」																														
TCH30A「」, TCH30A「」-11A	TCH30A「」																														
TCH30C「」	TCH30C「」																														

9. SIMILAR TO TO-220 TYPE

マーキング仕様 Marking
<p>(Single Chip)</p> <p>①社名略マーク (N) Manufacturer's Mark(N)</p> <p>②製造年月 Lot No.</p> <p>③型名 Type No.</p> <p>④極性 Polarity Mark</p> <p>(Fully Molded Case)</p>
<p>(Single Chip)</p> <p>①社名略マーク (N) Manufacturer's Mark(N)</p> <p>②製造年月 Lot No.</p> <p>③型名 Type No.</p> <p>④極性 Polarity Mark</p> <p>(Fully Molded Case)</p>

勝特力材料 886-3-5753170
胜特力电子(上海) 86-21-34970699
胜特力电子(深圳) 86-755-83298787
[Http://www.100y.com.tw](http://www.100y.com.tw)

Continued on the following page.

Continued from the preceding page

9. SIMILAR TO TO-220 TYPE

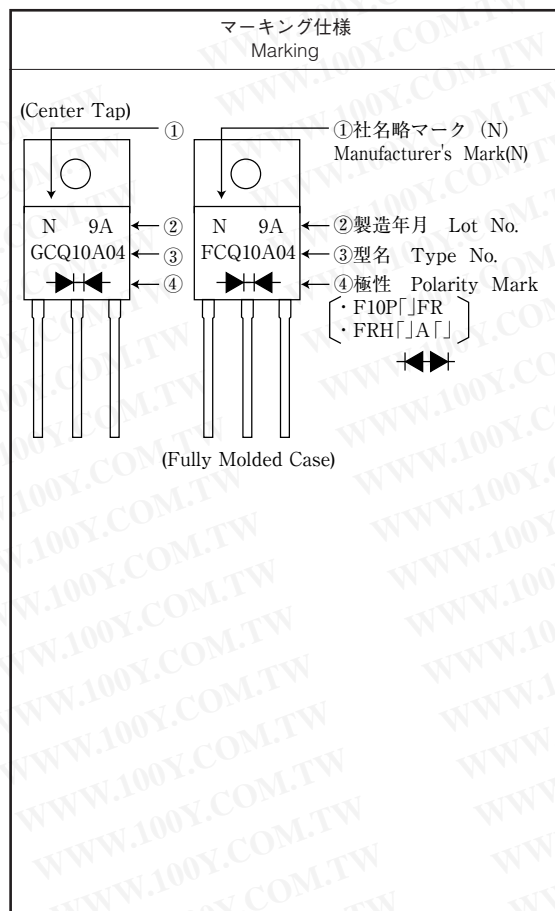

10. SIMILAR TO TO-247 TYPE

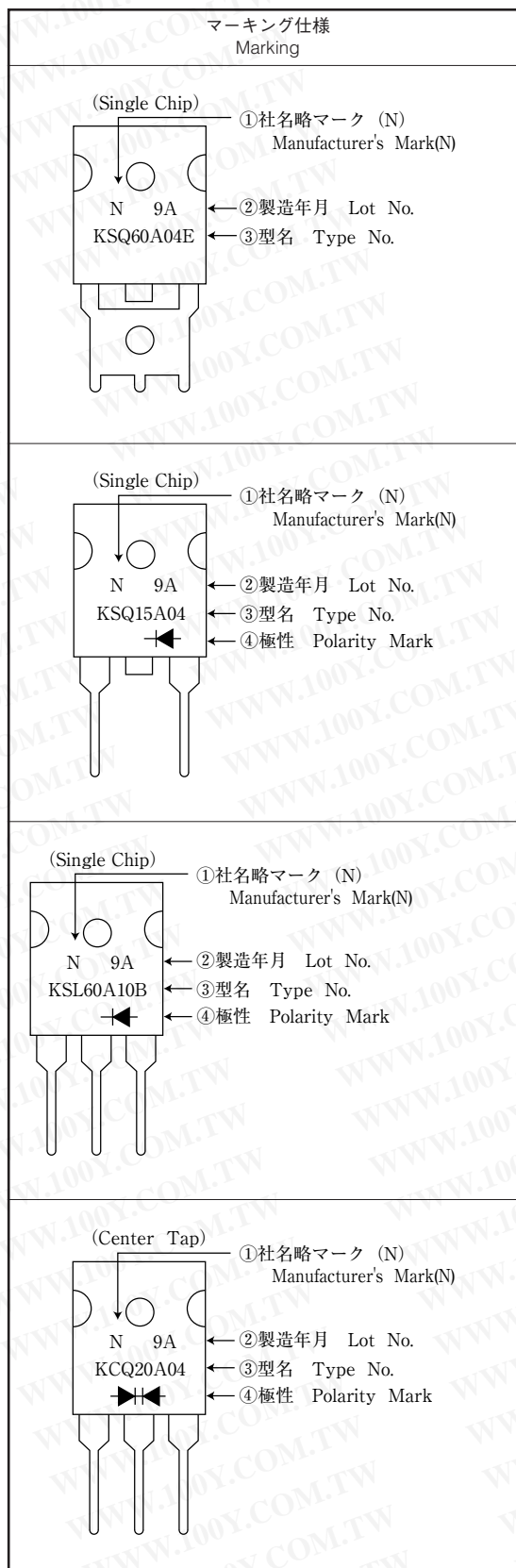

勝特力材料 886-3-5753170
 胜特力电子(上海) 86-21-34970699
 胜特力电子(深圳) 86-755-83298787
[Http://www.100y.com.tw](http://www.100y.com.tw)