

## IGBT MODULE ( S-Series )

### ■ Features

- NPT-Technologie
- Solderable Package
- Square SC SOA at  $10 \times I_C$
- High Short Circuit Withstand-Capability
- Small Temperature Dependence of the Turn-Off Switching Loss
- Low Losses And Soft Switching

### ■ Applications

- High Power Switching
- A.C. Motor Controls
- D.C. Motor Controls
- Uninterruptible Power Supply

勝特力材料 886-3-5753170  
 勝特力电子(上海) 86-21-34970699  
 勝特力电子(深圳) 86-755-83298787  
[Http://www.100y.com.tw](http://www.100y.com.tw)

### ■ Outline Drawing

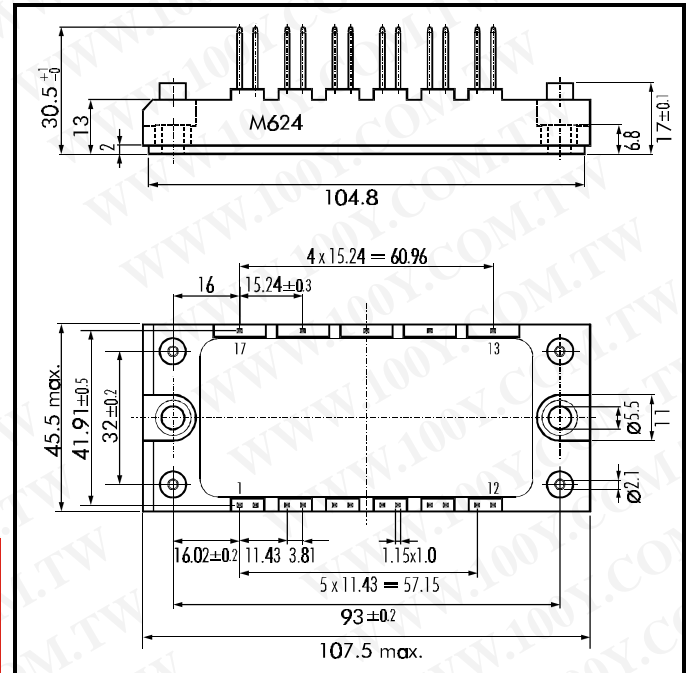

### ■ Maximum Ratings and Characteristics

#### • Absolute Maximum Ratings ( $T_c=25^\circ\text{C}$ )

Items	Symbols	Ratings	Units
Collector-Emitter Voltage	$V_{CES}$	1200	V
Gate -Emitter Voltage	$V_{GES}$	$\pm 20$	V
Collector Current (25°C / 80°C)	Continuous	$I_C$	35 / 25
	1ms	$I_{C\ PULSE}$	70 / 50
	Continuous	$-I_C$	35 / 25
	1ms	$-I_{C\ PULSE}$	70 / 50
Max. Power Dissipation	$P_C$	200	W
Operating Temperature	$T_j$	+150	°C
Storage Temperature	$T_{stg}$	-40 ~ +125	°C
Isolation Voltage	A.C. 1min. $V_{is}$	2500	V
Screw Torque	Mounting *1	3.5	Nm

Note: \*1:Recommendable Value; 2.5 ~ 3.5 Nm (M5)

### ■ Equivalent Circuit

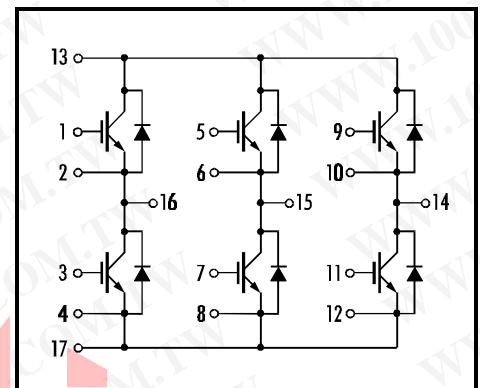

#### • Electrical Characteristics ( at $T_j=25^\circ\text{C}$ )

Items	Symbols	Test Conditions	Min.	Typ.	Max.	Units
Zero Gate Voltage Collector Current	$I_{CES}$	$V_{GE}=0V\ V_{CE}=1200V$			1.0	mA
Gate-Emitter Leakage Current	$I_{GES}$	$V_{CE}=0V\ V_{GE}=\pm 20V$			200	$\mu\text{A}$
Gate-Emitter Threshold Voltage	$V_{GE(th)}$	$V_{GE}=20V\ I_C=25\text{mA}$	6.0		9.0	V
Collector-Emitter Saturation Voltage	$V_{CE(sat)}$	$V_{GE}=15V\ I_C=25A$				V
Input capacitance	$C_{ies}$	$V_{GE}=0V$		3300		pF
Output capacitance	$C_{oes}$	$V_{CE}=10V$				
Reverse Transfer capacitance	$C_{res}$	$f=1\text{MHz}$				
Turn-on Time	$t_{ON}$	$V_{CC}=600V$		0.60	1.2	$\mu\text{s}$
	$t_r$	$I_C=25A$		0.40	0.6	
Turn-off Time	$t_{OFF}$	$V_{GE}=\pm 15V$		0.45	1.0	$\mu\text{s}$
	$t_f$	$R_G=51\Omega$		0.10	0.3	
Diode Forward On-Voltage	$V_F$	$I_F=25A\ V_{GE}=0V$			3.3	V
Reverse Recovery Time	$t_{rr}$	$I_F=25A$			350	ns

#### • Thermal Characteristics

Items	Symbols	Test Conditions	Min.	Typ.	Max.	Units
Thermal Resistance	$R_{th(j-c)}$	IGBT			0.62	°C/W
	$R_{th(j-e)}$	Diode			1.00	
	$R_{th(c-f)}$	With Thermal Compound		0.05		