

# FDMC6890NZ

## Dual N-Channel PowerTrench® MOSFET

20V, 4A, Q1:68mΩ, Q2:100mΩ

### Features

Q1: N-Channel

- Max  $r_{DS(on)}$  = 68mΩ at  $V_{GS} = 4.5V$ ,  $I_D = 4A$
- Max  $r_{DS(on)}$  = 100mΩ at  $V_{GS} = 2.5V$ ,  $I_D = 3A$

Q2: N-Channel

- Max  $r_{DS(on)}$  = 100mΩ at  $V_{GS} = 4.5V$ ,  $I_D = 4A$
- Max  $r_{DS(on)}$  = 150mΩ at  $V_{GS} = 2.5V$ ,  $I_D = 2A$
- Low gate Charge
- RoHS Compliant



### General Description

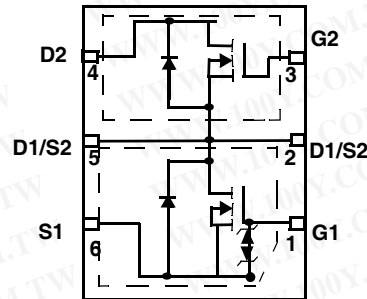
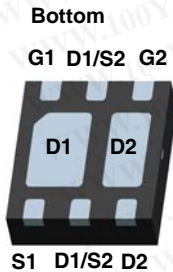
FDMC6890NZ is a compact single package solution for DC to DC converters with excellent thermal and switching characteristics. Inside the Power 33 package features two N-channel MOSFETs with low on-state resistance and low gate charge to maximize the power conversion and switching efficiency. The Q1 switch also integrates gate protection from unclamped voltage input.

### Application

- DC - DC Conversion



Power 33



### MOSFET Maximum Ratings $T_A = 25^\circ C$ unless otherwise noted

Symbol	Parameter	Q1	Q2	Units
$V_{DS}$	Drain to Source Voltage	20	20	V
$V_{GS}$	Gate to Source Voltage	±12	±12	V
$I_D$	-Continuous	4		A
	-Pulsed	10		
$P_D$	Power Dissipation (Steady State) Q1	(Note 1a)	1.92	W
	Power Dissipation (Steady State) Q2		1.78	
$T_J, T_{STG}$	Operating and Storage Junction Temperature Range	-55 to +150		°C

### Thermal Characteristics

$R_{\theta JA}$	Thermal Resistance, Junction to Ambient	Q1	(Note 1a)	65	°C/W
$R_{\theta JA}$	Thermal Resistance, Junction to Ambient	Q2		70	

### Package Marking and Ordering Information

Device Marking	Device	Package	Reel Size	Tape Width	Quantity
6890N	FDMC6890NZ	Power 33	7inch	8mm	3000 units

**Electrical Characteristics**  $T_J = 25^\circ\text{C}$  unless otherwise noted

Symbol	Parameter	Test Conditions	Type	Min	Typ	Max	Units
--------	-----------	-----------------	------	-----	-----	-----	-------

**Off Characteristics**

$BV_{DSS}$	Drain to Source Breakdown Voltage	$I_D = 250\mu\text{A}$ , $V_{GS} = 0\text{V}$	Q1 Q2	20 20			V
$\frac{\Delta BV_{DSS}}{\Delta T_J}$	Breakdown Voltage Temperature Coefficient	$I_D = 250\mu\text{A}$ , referenced to $25^\circ\text{C}$	Q1 Q2		13 12		mV/ $^\circ\text{C}$
$I_{DSS}$	Zero Gate Voltage Drain Current	$V_{DS} = 16\text{V}$ , $V_{GS} = 0\text{V}$	Q1 Q2			1 1	$\mu\text{A}$
$I_{GSS}$	Gate to Source Leakage Current	$V_{GS} = \pm 12\text{V}$ , $V_{DS} = 0\text{V}$	Q1 Q2			$\pm 10$ $\pm 100$	$\mu\text{A}$ nA

**On Characteristics**

$V_{GS(th)}$	Gate to Source Threshold Voltage	$V_{GS} = V_{DS}$ , $I_D = 250\mu\text{A}$	Q1 Q2	0.6 0.6	0.9 1.0	2 2	V
$\frac{\Delta V_{GS(th)}}{\Delta T_J}$	Gate to Source Threshold Voltage Temperature Coefficient	$I_D = 250\mu\text{A}$ , referenced to $25^\circ\text{C}$	Q1 Q2		-3 -3		mV/ $^\circ\text{C}$
$r_{DS(on)}$	Drain to Source On Resistance	$V_{GS} = 4.5\text{V}$ , $I_D = 4\text{A}$ $V_{GS} = 2.5\text{V}$ , $I_D = 3\text{A}$	Q1		58 77	68 100	m $\Omega$
		$V_{GS} = 4.5\text{V}$ , $I_D = 4\text{A}$ $V_{GS} = 2.5\text{V}$ , $I_D = 2\text{A}$	Q2		67 102	100 150	
$g_{FS}$	Forward Transconductance	$V_{DS} = \text{V}$ , $I_D = 4\text{A}$	Q1 Q2		10 7		S

**Dynamic Characteristics**

$C_{iss}$	Input Capacitance	$V_{DS} = 10\text{V}$ , $V_{GS} = 0\text{V}$ , $f = 1\text{MHz}$	Q1 Q2		205 190	270 250	pF
$C_{oss}$	Output Capacitance		Q1 Q2		60 60	80 80	
$C_{rss}$	Reverse Transfer Capacitance		Q1 Q2		40 35	60 55	
$R_g$	Gate Resistance	$f = 1\text{MHz}$	Q1 Q2		3.3 2.8		$\Omega$

**Switching Characteristics**

$t_{d(on)}$	Turn-On Delay Time	$V_{DD} = 10\text{V}$ , $I_D = 4\text{A}$ , $R_{GEN} = 6\Omega$	Q1 Q2		4 4	10 10	ns
$t_r$	Rise Time		Q1 Q2		13 12	22 21	
$t_{d(off)}$	Turn-Off Delay Time		Q1 Q2		10 7	19 14	
$t_f$	Fall Time		Q1 Q2		6 6	12 12	
$Q_{g(TOT)}$	Total Gate Charge at 4.5V	$V_{GS} = 0\text{V}$ to $4.5\text{V}$	Q1 Q2		2.4 1.8	3.4 2.6	nC
$Q_{g(2)}$	Total Gate Charge at 2V	$V_{DD} = 10\text{V}$ $I_D = 4\text{A}$	Q1 Q2		1.4 0.6	1.9 0.8	
$Q_{gs}$	Gate to Source Gate Charge		Q1 Q2		0.4 0.5		
$Q_{gd}$	Gate to Drain "Miller" Charge		Q1 Q2		0.9 0.8		

**Electrical Characteristics**  $T_J = 25^\circ\text{C}$  unless otherwise noted

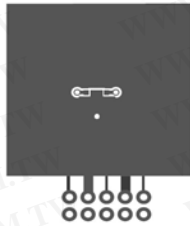
Symbol	Parameter	Test Conditions	Type	Min	Typ	Max	Units
--------	-----------	-----------------	------	-----	-----	-----	-------

**Drain-Source Diode Characteristics**

$V_{SD}$	Source to Drain Diode Forward Voltage	$V_{GS} = 0\text{V}, I_S = 4\text{A}$	Q1 Q2	0.94 0.92	1.25 1.25		V
$t_{rr}$	Reverse Recovery Time	$I_F = 4\text{A}, di/dt = 100\text{A/s}$	Q1 Q2	18 17	27 26		ns
$Q_{rr}$	Reverse Recovery Charge		Q1 Q2	9 10	14 15		nC

**Notes:**

1:  $R_{\theta JA}$  is determined with the device mounted on a  $1\text{in}^2$  pad 2 oz copper pad on a  $1.5 \times 1.5\text{in.}$  board of FR-4 material.  $R_{\theta JC}$  is guaranteed by design while  $R_{\theta CA}$  is determined by the user's board design.



a.  $65^\circ\text{C/W}$  when mounted on a  $1\text{in}^2$  pad of 2 oz copper



b.  $150^\circ\text{C/W}$  when mounted on a minimum pad of 2 oz copper

2: Pulse Test: Pulse Width  $< 300\mu\text{s}$ , Duty cycle  $< 2.0\%$ .

**Typical Characteristics (Q1 N-Channel)**  $T_J = 25^\circ\text{C}$  unless otherwise noted

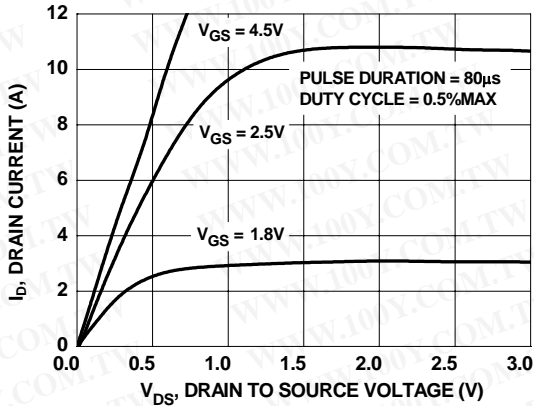


Figure 1. On-Region Characteristics

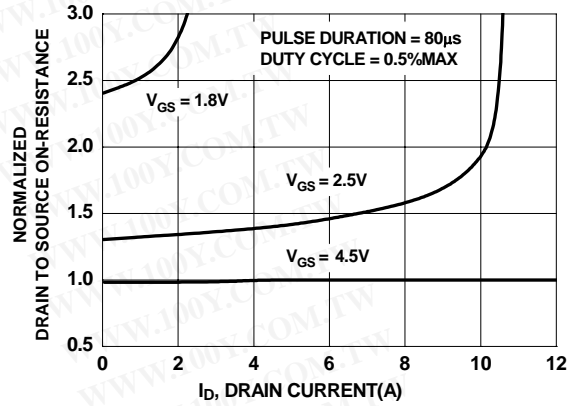


Figure 2. Normalized On-Resistance vs Drain Current and Gate Voltage

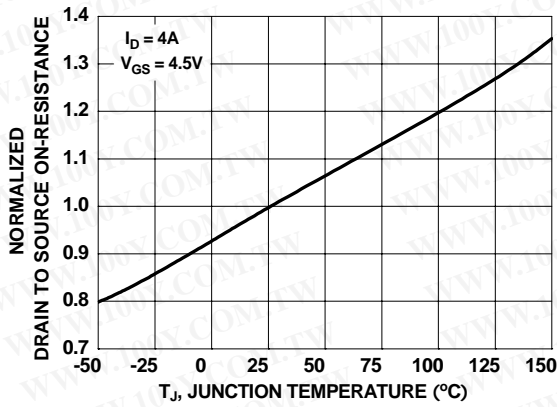


Figure 3. Normalized On-Resistance vs Junction Temperature

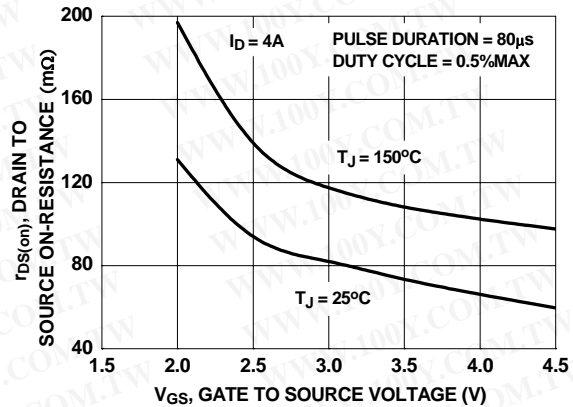


Figure 4. On-Resistance vs Gate to Source Voltage

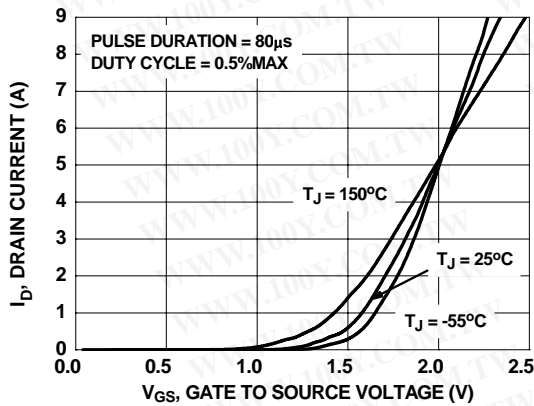


Figure 5. Transfer Characteristics

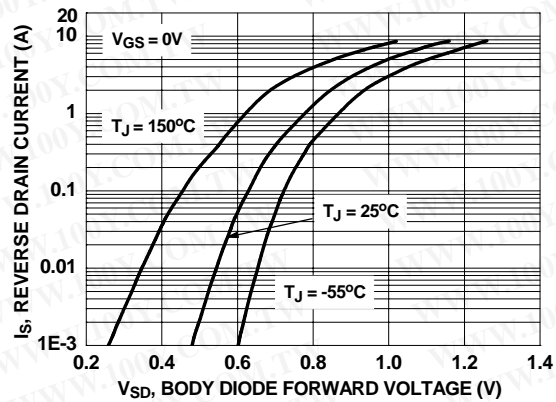
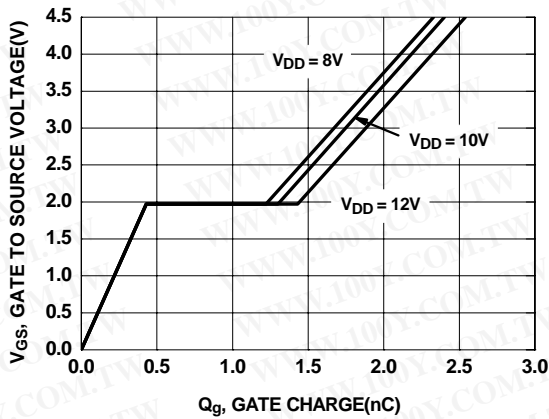
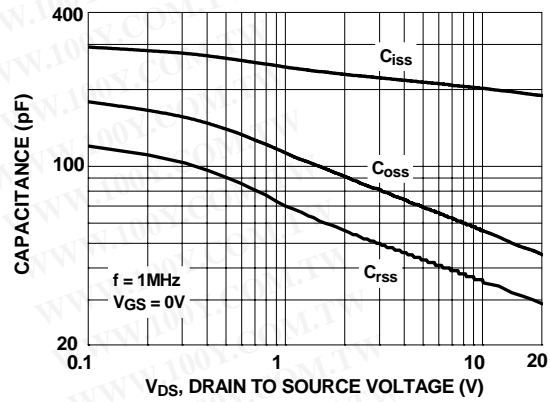


Figure 6. Source to Drain Diode Forward Voltage vs Source Current

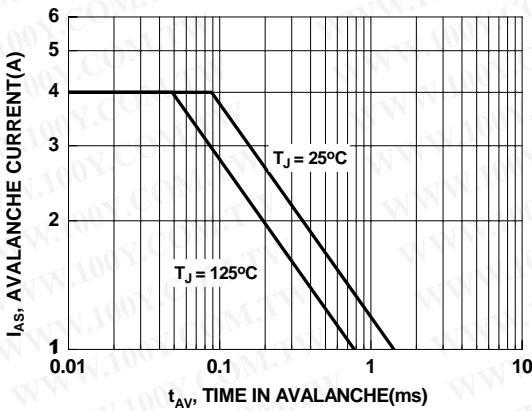
**Typical Characteristics (Q1 N-Channel)**  $T_J = 25^\circ\text{C}$  unless otherwise noted



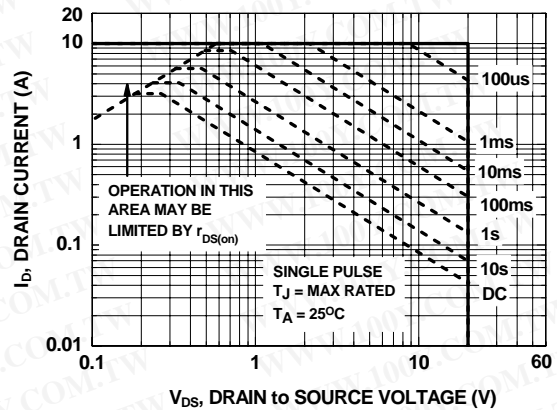
**Figure 7. Gate Charge Characteristics**



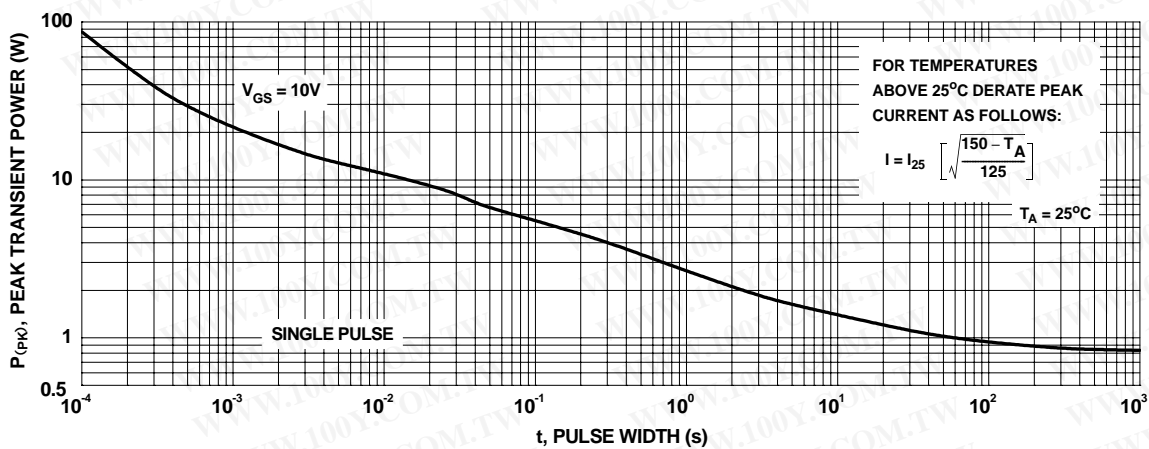
**Figure 8. Capacitance vs Drain to Source Voltage**



**Figure 9. Unclamped Inductive Switching Capability**

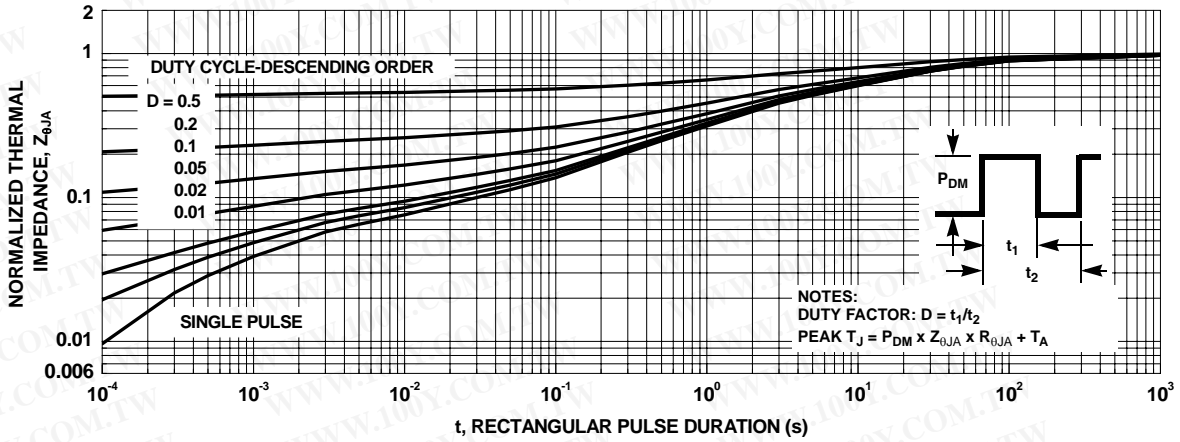


**Figure 10. Forward Bias Safe Operating Area**



**Figure 11. Single Pulse Maximum Power Dissipation**

**Typical Characteristics (Q1 N-Channel)**  $T_J = 25^\circ\text{C}$  unless otherwise noted



**Figure 12. Transient Thermal Response Curve**

### Typical Characteristics (Q2 N-Channel)

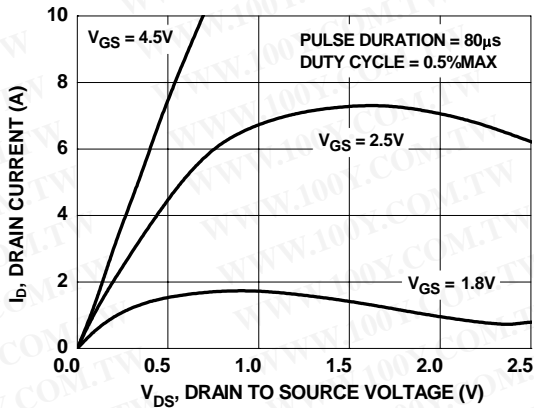


Figure 13. On Region Characteristics

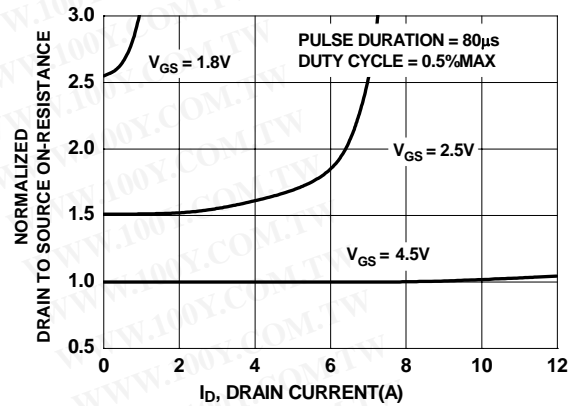


Figure 14. Normalized on-Resistance vs Drain Current and Gate Voltage

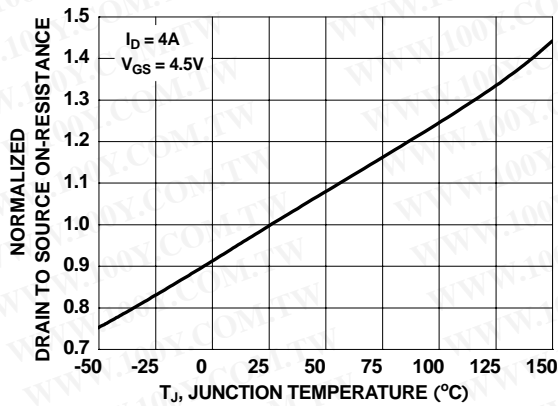


Figure 15. Normalized On Resistance vs Junction Temperature

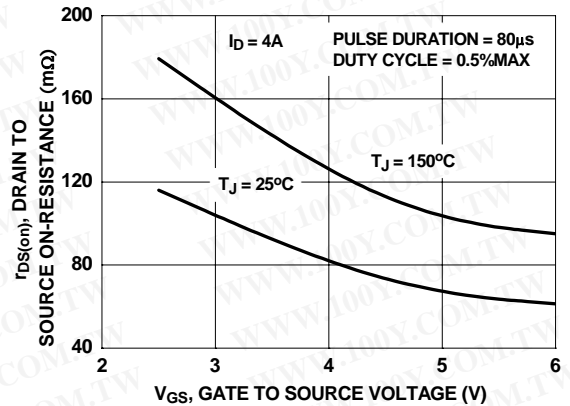


Figure 16. On-Resistance vs Gate to Source Voltage

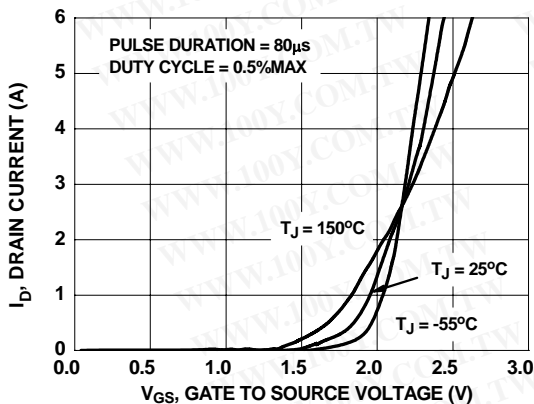


Figure 17. Transfer Characteristics

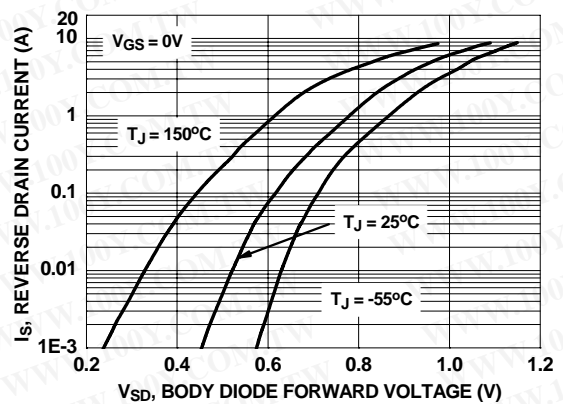


Figure 18. Source to Drain Diode Forward Voltage vs Source Current

### Typical Characteristics

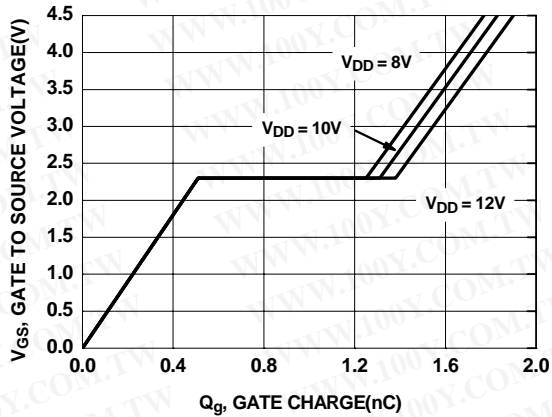


Figure 19. Gate Charge Characteristics

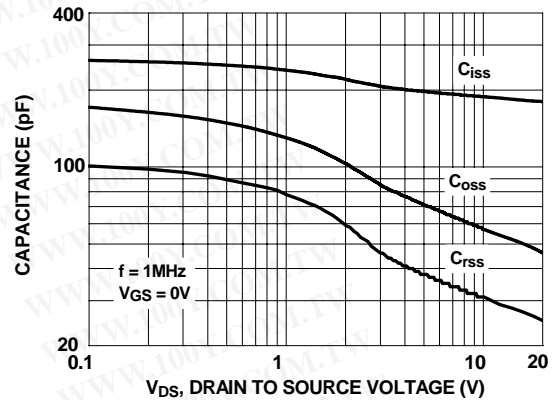


Figure 20. Capacitance vs Drain to Source Voltage

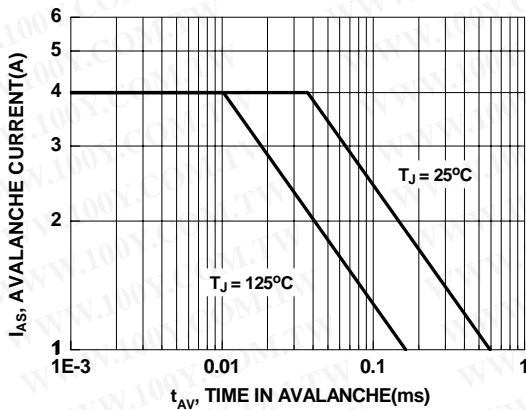


Figure 21. Unclamped Inductive Switching Capability

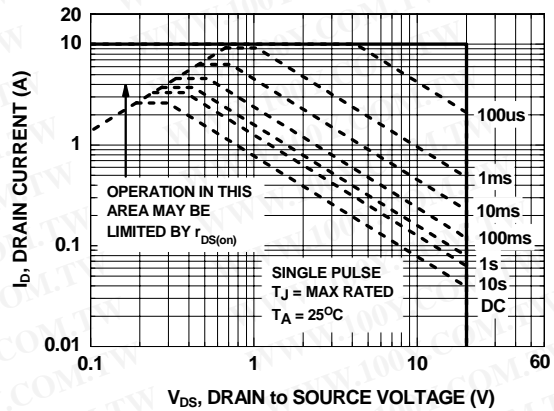


Figure 22. Forward Bias Safe Operating Area

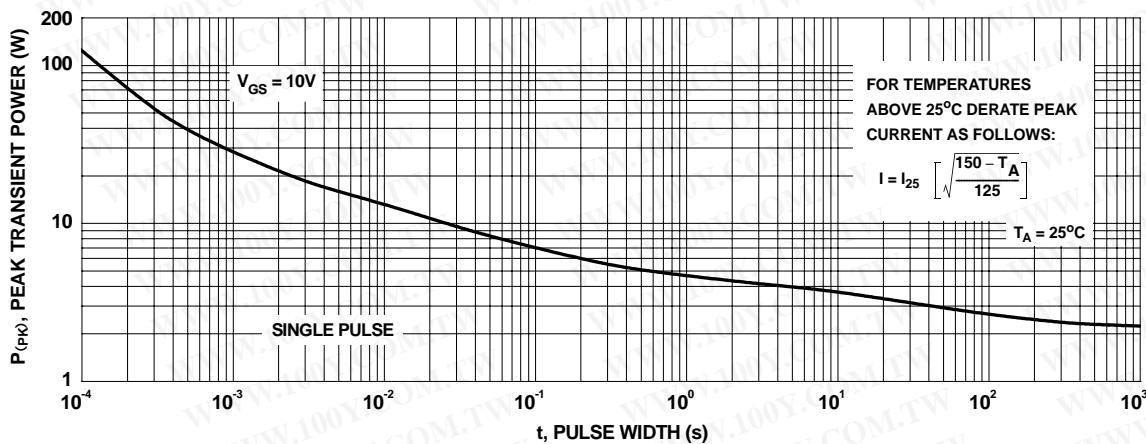
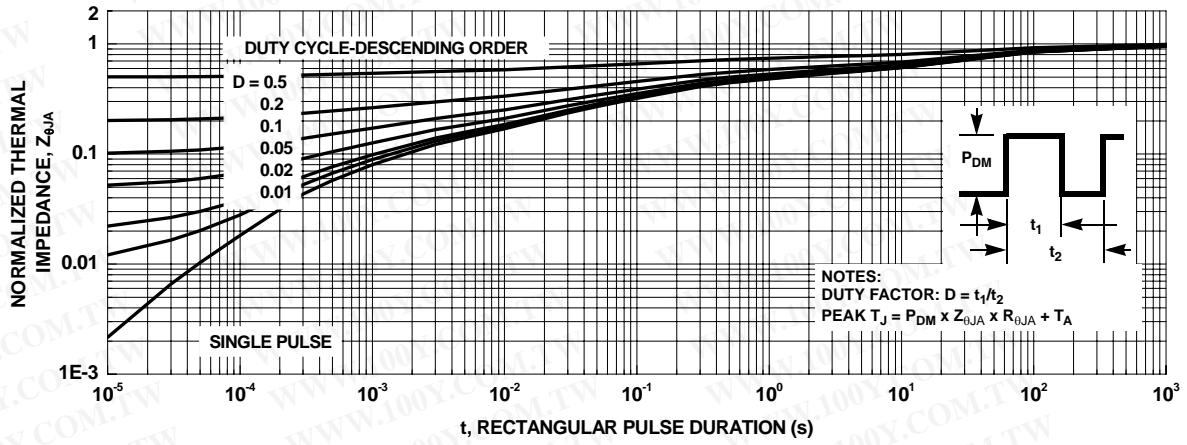
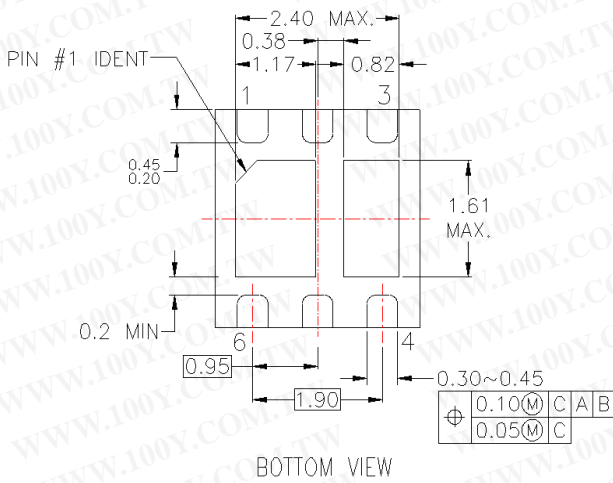
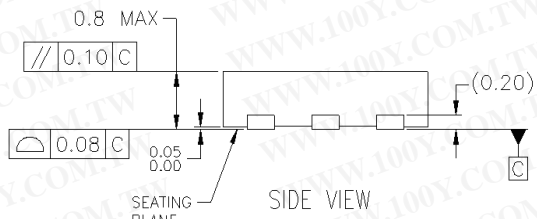
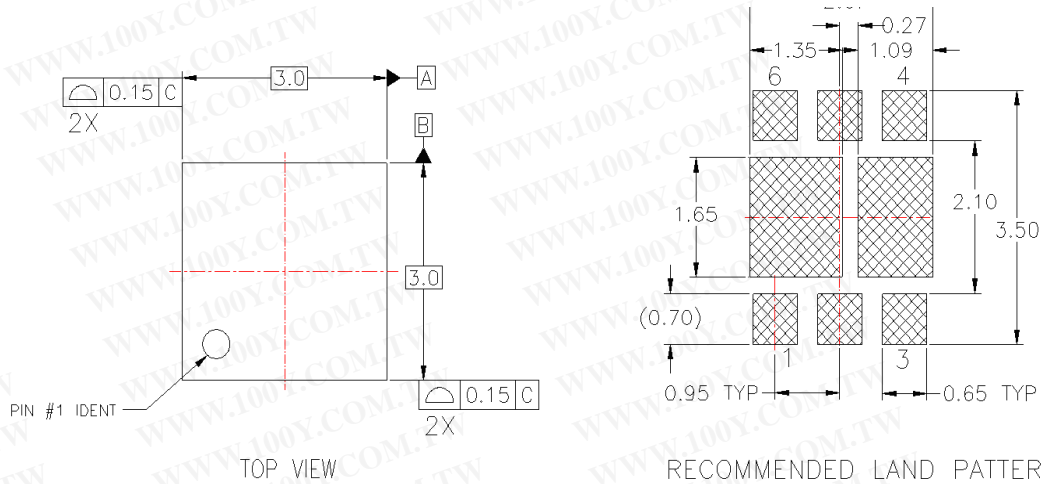


Figure 23. Single Pulse Maximum Power Dissipation

**Typical Characteristics**





NOTES:

- A. CONFORMS TO JEDEC REGISTRATION MO-229, VARIATION WEEA, DATED 11/2001
- B. DIMENSIONS ARE IN MILLIMETERS.
- C. DIMENSIONS AND TOLERANCES PER ASME Y14.5M, 1994

MLP06HrevA

## TRADEMARKS

The following are registered and unregistered trademarks Fairchild Semiconductor owns or is authorized to use and is not intended to be an exhaustive list of all such trademarks.

ACEx™	FACT Quiet Series™	OCX™	SILENT SWITCHER®	UniFET™
ActiveArray™	GlobalOptoisolator™	OCXPro™	SMART START™	UltraFET®
Bottomless™	GTO™	OPTOLOGIC®	SPM™	VCX™
Build it Now™	HiSeC™	OPTOPLANAR™	Stealth™	Wire™
CoolFET™	I <sup>2</sup> C™	PACMAN™	SuperFET™	
CROSSVOLT™	i-Lo™	POP™	SuperSOT™-3	
DOMETM™	ImpliedDisconnect™	Power247™	SuperSOT™-6	
EcoSPARK™	IntelliMAX™	PowerEdge™	SuperSOT™-8	
E <sup>2</sup> CMOS™	ISOPLANAR™	PowerSaver™	SyncFET™	
EnSigna™	LittleFET™	PowerTrench®	TCM™	
FACT™	MICROCOUPLER™	QFET®	TinyBoost™	
FAST®	MicroFET™	QS™	TinyBuck™	
FASTr™	MicroPak™	QT Optoelectronics™	TinyPWM™	
FPST™	MICROWIRE™	Quiet Series™	TinyPower™	
FRFET™	MSX™	RapidConfigure™	TinyLogic®	
	MSXPro™	RapidConnect™	TINYOPTO™	
Across the board. Around the world.™		µSerDes™	TruTranslation™	
The Power Franchise®		ScalarPump™	UHC™	
Programmable Active Droop™				

## DISCLAIMER

FAIRCHILD SEMICONDUCTOR RESERVES THE RIGHT TO MAKE CHANGES WITHOUT FURTHER NOTICE TO ANY PRODUCTS HEREIN TO IMPROVE RELIABILITY, FUNCTION OR DESIGN. FAIRCHILD DOES NOT ASSUME ANY LIABILITY ARISING OUT OF THE APPLICATION OR USE OF ANY PRODUCT OR CIRCUIT DESCRIBED HEREIN; NEITHER DOES IT CONVEY ANY LICENSE UNDER ITS PATENT RIGHTS, NOR THE RIGHTS OF OTHERS. THESE SPECIFICATIONS DO NOT EXPAND THE TERMS OF FAIRCHILD'S WORLDWIDE TERMS AND CONDITIONS, SPECIFICALLY THE WARRANTY THEREIN, WHICH COVERS THESE PRODUCTS.

## LIFE SUPPORT POLICY

FAIRCHILD'S PRODUCTS ARE NOT AUTHORIZED FOR USE AS CRITICAL COMPONENTS IN LIFE SUPPORT DEVICES OR SYSTEMS WITHOUT THE EXPRESS WRITTEN APPROVAL OF FAIRCHILD SEMICONDUCTOR CORPORATION.

As used herein:

- Life support devices or systems are devices or systems which, (a) are intended for surgical implant into the body, or (b) support or sustain life, or (c) whose failure to perform when properly used in accordance with instructions for use provided in the labeling, can be reasonably expected to result in significant injury to the user.
- A critical component is any component of a life support device or system whose failure to perform can be reasonably expected to cause the failure of the life support device or system, or to affect its safety or effectiveness.

## PRODUCT STATUS DEFINITIONS

### Definition of Terms

Datasheet Identification	Product Status	Definition
Advance Information	Formative or In Design	This datasheet contains the design specifications for product development. Specifications may change in any manner without notice.
Preliminary	First Production	This datasheet contains preliminary data, and supplementary data will be published at a later date. Fairchild Semiconductor reserves the right to make changes at any time without notice in order to improve design.
No Identification Needed	Full Production	This datasheet contains final specifications. Fairchild Semiconductor reserves the right to make changes at any time without notice in order to improve design.
Obsolete	Not In Production	This datasheet contains specifications on a product that has been discontinued by Fairchild semiconductor. The datasheet is printed for reference information only.

Rev. 120