

勝特力材料 886-3-5753170  
勝特力电子(上海) 86-21-34970699  
勝特力电子(深圳) 86-755-83298787  
Http://www.100y.com.tw

power electronics in motion  
**eupec**

# **EiceDRIVER™**

## **2ED300C17-S** **2ED300C17-ST**

### **Dual IGBT Driver for Medium and High Power IGBTs**

### **Datasheet and Application Note**

Prepared by : M.Hornkamp	Date of publication: 16.05.2003
Approved by: Reg.Nr.064-02	Revision: 3.0
SN: 23925 SN:24816	Status: <b>preliminary</b>

eupec GmbH  
Max-Planck-Straße 5  
D-59581 Warstein  
Author: Michael Hornkamp  
Tel. +49(0)2902 764-0  
Fax +49(0)2902 764-1150  
Email: info@eupec.com

[www.eupec.com](http://www.eupec.com)



Passing on of this document or its contents to company external personnel requires written consent. Usage and copying of the contents to other media is prohibited. Violations will be prosecuted for damages. All rights reserved, including such arising from issue of patents or registration of trade marks or design.

© eupec GmbH 2002. All rights reserved.

Correspondence of the contents of this document with the described hardware has been checked. Discrepancies may exist nevertheless; no guaranty is assumed for total congruence. The information contained in this document is subject to regular revision. Any alterations required will be incorporated in the next issue. Suggestions for improvement are welcome. Changes of the document may occur without prior notice.

## Safety notice!

It must be prevented that children and the general public have access to the installed driver or can get into proximity!

The driver may only be used for the purposes prescribed by the manufacturer. Inadmissible alterations and use of spare parts and accessories not recommend by the manufacturer of the driver can cause fire, electric shock and injuries.

This document has to be at the disposal of all users, developers and qualified personnel who are to work with the driver.

If measurements and tests on the live device have to be carried out, then the regulations of the Safety Code VBG 4.0 are to be observed, in particular § 8 "Admissible deviations during work on live parts". Suitable electronic devices are to be used.

Prior to installation and commissioning please read this document thoroughly.

- Commissioning is prohibited if there is visible damage by inappropriate handling or transport.
- Contact while uninstalled is permitted only with ESD protection.
- Install only without supply voltage.
- Always keep sufficient safety distance during commissioning without closed protective housing.
- Contact under live condition is strictly prohibited.
- Work after turn-off is not admissible until the absence of supply voltage has been verified.
- During work after turn-off it has to be observed that components heat up during operation. Contact with these can cause burning.
- The drivers are mounted electrically and mechanically into a mother board by soldering. The mechanical strength has to be verified by the user and, if necessary, assured with appropriate tests.
- The drivers are designed for use with eupec IGBT Modules type IHM, EconoPACK+, 62mm. In case of ulterior use, safe operation cannot be guaranteed.

**General Information 2ED300C17-S:**

This datasheet describes the dual channel IGBT driver 2ED300C17-S for industrial application and the 2ED300C17-ST for traction application. The Drivers are separated in two temperature classes  $-25^{\circ}\text{C}$  for the 2ED300C17-S and  $-40^{\circ}\text{C}$  for the 2ED300C17ST. The electrical function and the mechanic dimension are in both version similar. Only if there is a different in the types the 2ED300C17-ST is called.

The 2ED300C17-S is one of the *EiceDRIVER™* driver family. (**eupec IGBT controlled efficiency DRIVER**). The 2ED300C17-S IGBT driver is designed for use with eupec IGBT modules of the 1200V and 1700V series. Functions of the 2ED300C17-S such as the "soft shut down" or the  $V_{\text{CEsat}}$  reference curves have to be adapted to the individual modules. This is described in the following chapters.

The 2ED300C17-S is designed for applications with high safety and reliability requirements and aims for power ratings of 75kW to 1MW.

To offer high interference suppression, +15V is generally used for control. The entire logic processing is also done with +15V. The integrated transformer is separated into three sections:

Two pulse transformers and a dual channel DC-DC switch mode power supply. These are designed such that they offer lowest coupling capacitances and high isolation stability.

The 2ED300C17-S is additionally equipped with a feed-back "Sense" input. This input can **optionally** be connected with the active clamping or di/dt and dv/dt control.

The clearance and creepage distances comply with VDE0110 and VDE0160 / EN50178 and are designed for pollution degree 3. Materials of the transformer meet requirements of UL94V0. Protection degree IP00.

To protect from undefined switching of IGBTs in case of a gate-emitter short circuit of another IGBT, the supply voltage  $V_{\text{A,B+}}$ ;  $V_{\text{A,B-}}$  is internally monitored in the driver for short circuit currents. In case of a gate-emitter short the secondary circuit is interrupted and thus the primary voltage maintained.

**Exclusion clause:**

The datasheet is part of the eupec IGBT driver 2ED300C17-S. To guaranty safe and fault free operation it is **necessary** to have read and understood this datasheet.

The eupec IGBT driver 2ED300C17-S is only intended for control of eupec IGBT modules. The company eupec GmbH cannot warrant against damage and/or dysfunction if IGBT modules used not produced by eupec.

In this context, eupec GmbH retains the right to change technical data and product specifications without prior notice to the course of improvement.

Chapter:		Page
	<ul style="list-style-type: none"> <li>•Safety notice</li> <li>•General information</li> <li>•Exclusion clause</li> <li>•Contents</li> </ul>	<p>2</p> <p>3</p> <p>3</p> <p>4</p>
<b>1.</b>	<b>Datasheet</b>	<b>5</b>
1.2	•Features	5
1.3	•Key data	5
1.4	•Block diagram	6
1.5	•Inputs and outputs	6
1.6	•Pin configuration	7
1.7	•Maximum permissible values	8
1.8	•Characteristic values	9
1.9	•Max. switching frequency at different rated currents	10
1.10	•Mechanical dimensions	11
<b>2.</b>	<b>The transformer</b>	<b>12</b>
2.1	• Safe electrical isolation Protection Class II according to EN50178	12
<b>3.</b>	<b>Application of the 2ED300C17-S</b>	<b>13</b>
3.1	•Power supply	13
3.1.1	•Use of the internal over-current shut-down	
3.2	•Mode selection	14
3.3	•Interlock delay times	15
3.4	•Logic levels (reset; fault output)	16
3.5	•Signal level	17
3.6	•IGBT connection	17
3.7	•IGBT Shot circuit / IGBT overload shut down	20
3.8	•SSD “soft shut down”	23
3.9	•External fault input	25
3.10	•“Sense” input (SSD and active clamping)	25
3.11	•Additional output voltage / buffer capacitors	27
3.12	•Application example 2ED300C17-S	28
<b>4.</b>	<b>General</b>	<b>29</b>
4.1	Designation and symbols	29
4.2	Module internal gate resistors	30
4.3	Type designation	32

## 1.2 Features

- Dual channel IGBT driver 2ED300C17-S
- For 1200V / 1700V eupec IGBT modules
- $V_{CE\ sat}$  monitoring
- “Soft Shut Down” for fault conditions
- Save electrical isolation according to EN50178
- Integrated DC-DC SMPS
- High peak output current
- $\pm 15V$  secondary drive voltage
- Short signal transition time
- Optional “**Sence**” function
- High RFI immunity



## 1.3 Key data

Isolation testing voltage according to EN50178 protection class II	$V_{isol}$ pulse transformer and DC/DC	5000	$V_{AC}$
Max. output current:	$I_G$ per channel	$\pm 30$	A
Max. output power	$P_{DC/DC}$ per channel	4	W
Signal transition time	$t_{pd (on)}$ ; $t_{pd (off)}$	<670	ns
Minimal pulse suppression	$t_{md}$ turn on and turn off	400	ns
PWM drive voltage	$V_{in}$ drive level for channel A and B	+15	V
Supply voltage	Operating voltage $V_{DC}$ to ground	+15	$V_{DC}$
dv/dt stability	$dv/dt$ (* during test)	50*	kV/ $\mu$ s
Operating temperature direct on driver surface	$T_{op}$ 2ED300C17-S	-25 bis 85	°C
Operating temperature direct on driver surface	$T_{op}$ 2ED300C17-ST	-40 bis 85	°C

## 1.4 Block diagram 2ED300C17-S

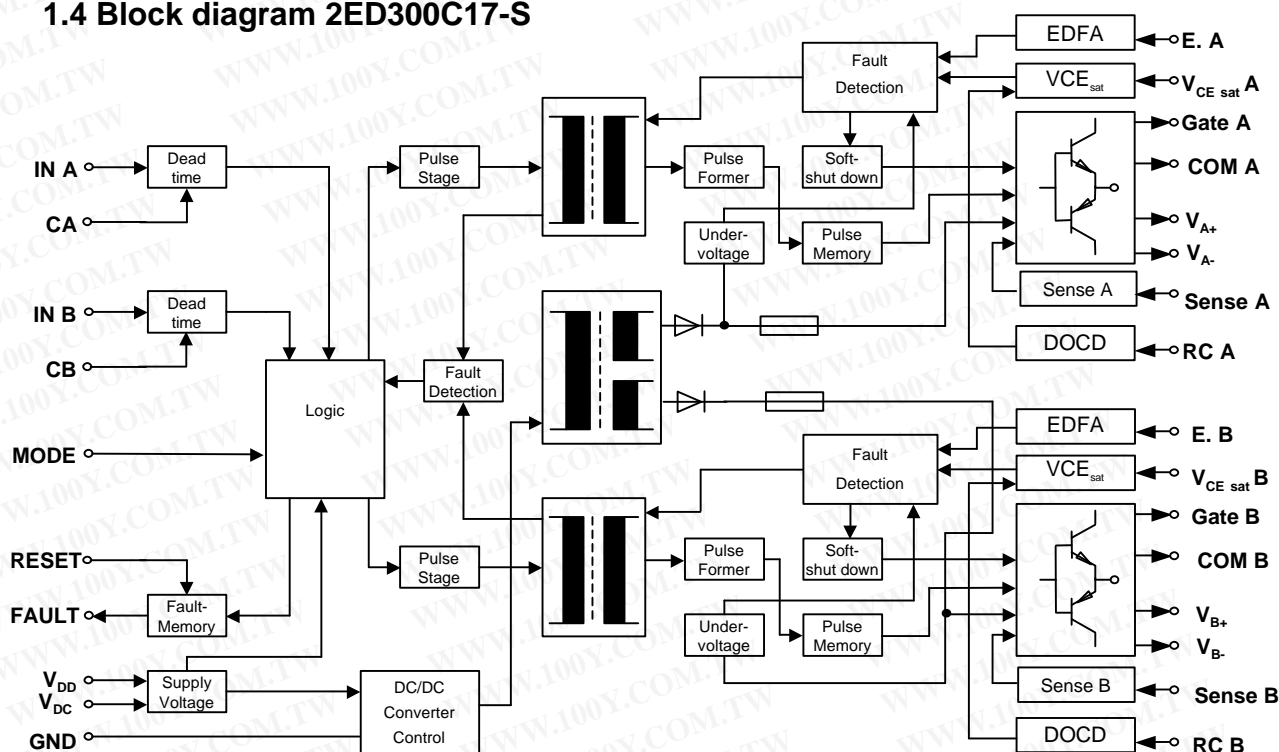

## 1.5 Inputs and outputs 2ED300C17-S

<b>IN A; IN B</b>	PWM signal inputs for channel A and channel B
<b>CA; CB</b>	Inputs for external interlock delay time generation for channel A and B in half bridge mode
<b>Mode</b>	Input for operating mode selection. Direct mode GND; half bridge mode +15V
<b>Reset</b>	With reset and operating PWM signals the primary fault memory is reset. Reset has active high logic. A high signal activates the reset.
<b>Fault</b>	The fault output indicates a fault. The fault output is open collector.
<b>V<sub>DC</sub></b>	Supply for the DC-DC SMPS
<b>V<sub>DD</sub></b>	Electronic supply
<b>GND</b>	GND is ground and reference point for all primary signals and the supply voltage
<b>E.A; E.B</b>	External fault input. Is used to set the fault memory by an external signal.
<b>V<sub>CE sat</sub> A; B</b>	Input for the saturation voltage monitoring
<b>Gate A; B</b>	Driver output to the IGBT module gate via an external gate resistor
<b>COM A; B</b>	COM A; B is connected to the auxiliary emitters of the IGBT module
<b>V<sub>A+</sub>; V<sub>A-</sub>; V<sub>B+</sub>; V<sub>B-</sub></b>	Non-isolated supply voltage for additional use and connection of the buffer capacitors
<b>Sense</b>	Control input for the optional di/dt or dv/dt control, setting of the soft shut down or active clamping
<b>RC A; RC B</b>	RC network for V <sub>CE sat</sub> reference curve

## 1.6 Pin configuration of the 2ED300C17-S

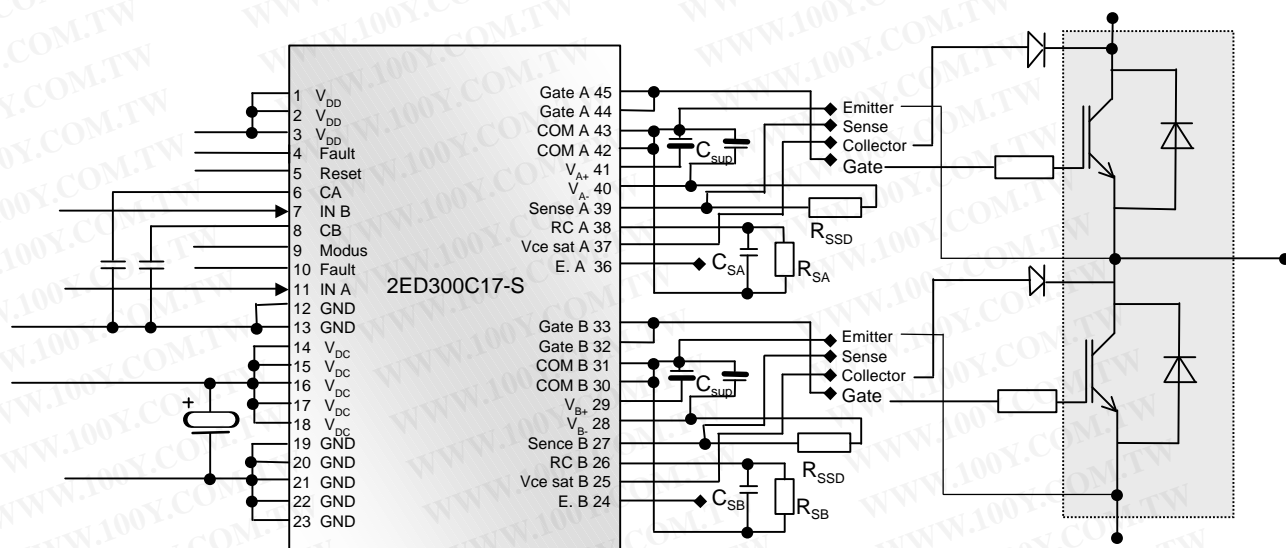

Figure 1.6 Pin configuration of the 2ED300C17-S

Pin	Label	Function	Pin	Label	Function
1	V <sub>DD</sub>	+15V for electronics primary			
2	V <sub>DD</sub>	+15V for electronics primary	45	Gate A	Gate channel A
3	V <sub>DD</sub>	+15V for electronics primary	44	Gate A	Gate channel A
4	Fault	Fault output	43	COM A	Reference point A
5	Reset	Logic level to reset channel A and B	42	COM A	Reference point A
6	CA	Delay time ch. A "half bridge mode"	41	V <sub>A+</sub>	+16V External buffer capacitor
7	IN B	PWM input B	40	V <sub>A-</sub>	-16V External buffer capacitor
8	CB	Delay time ch. B "half bridge mode"	39	Sense	SSD / clamping input
9	Mode	Mode selection	38	RC	Reference RC network channel A
10	Fault	Fault output	37	V <sub>CE sat</sub>	Collector sense channel A
11	IN A	PWM input A	36	E. A	External fault input channel A
12	GND	Ground for electronics primary	35		Physically non existent
13	GND	Ground for electronics primary	34		Physically non existent
14	V <sub>DC</sub>	+15V for SMPS	33	Gate B	Gate channel B
15	V <sub>DC</sub>	+15V for SMPS	32	Gate B	Gate channel B
16	V <sub>DC</sub>	+15V for SMPS	31	COM B	Reference point B
17	V <sub>DC</sub>	+15V for SMPS	30	COM B	Reference point B
18	V <sub>DC</sub>	+15V for SMPS	29	V <sub>B+</sub>	+16V External buffer capacitor
19	GND	Ground for SMPS	28	V <sub>B-</sub>	-16V External buffer capacitor
20	GND	Ground for SMPS	27	Sense	active- clamping / SSD
21	GND	Ground for SMPS	26	RC	Reference RC network channel B
22	GND	Ground for SMPS	25	V <sub>CE sat</sub>	Collector sense channel B
23	GND	Ground for SMPS	24	E. B	External fault input channel B

## 1.7 Maximum permissible values

Supply voltage $V_{DC}$	Maximum primary supply voltage	+16	V
PWM signal input voltage $V_{in}$	Max. voltage on inputs IN A; IN B	±20	V
Logic signal input voltage $V_{iH}$	Max. voltage (Mode; Reset)	±20	V
Logic signal output current $I_{OC}$	Fault output; max. continuous current open collector	20	mA
Peak output current ON $I_{G\ on}$	Max. driver peak output current	+30	A
Peak output current OFF $I_{G\ off}$	Max. driver peak output current	-30	A
Output current summed maximum $ I_{out} _{AV}$	Average value of the summed output current values per channel <sup>1)</sup>	133	mA
Maximum output power $P_{DC/DC}$	$P_{DC/DC}$ channelA + channel B	8	W
Maximum IGBT voltage $V_{CES}$	Maximum collector-emitter voltage on IGBT	1700	V
Isolation test voltage $V_{isol\ IO}$	Input- Output (RMS, 50Hz, 1s)	5000	V~
Isolation test voltage $V_{isol\ 12}$	Input A- Output B (RMS, 50Hz, 1s)	2250	V~
Surge voltage test $V_{isol\ Su}$	Surge test according to EN50178 Input to Output	9600	V
Gate resistor $R_{g\ min}$	Min. gate resistor (module internal + external gate resistor)	1	Ω
Gate capacity $C_{ies\ max}$	Maximum IGBT gate capacity	350	nF
<b>dv/dt</b>	Voltage slew rate secondary to primary site	50*	kV/ μs
$T_{op}$	Operating temperature 2ED300C17-S	-25.....+85	°C
$T_{op}$	Operating temperature 2ED300C17-ST	-40 .....+85	°C
$T_{sto.}$	Storage temperature	-40 .....+85	°C
$f_s\ max$ switching frequency	Max. switching frequency ( $T_{op}<65^{\circ}C$ $P_{DC/DC}=8W$ )	60'000	Hz
Supply current $I_{DC\ max.}$	Maximum continue permissible current draw of the dual driver	533	mA
$t_{TD\ min}$ min. interlock delay time	Factory set delay time in half-bridge mode	1,6	μs
<b>d</b> duty cycle	Maximum duty cycle	100	%

\* during test

• 133mA refer to gate input and additive ancillary voltage (see chapter 2.10)

$$|I_{out}|_{AV} = |I_G|_{AV} + I_{out}$$

## 1.8 Characteristic values

All values at +25°C	Min.	Typ.	Max.	Recommend.	
<b>V<sub>DC</sub></b> supply voltage primary DC-DC	+14	+15	+16	+15V	V
<b>I<sub>DC</sub></b> current draw DC-DC		80			mA
<b>I<sub>DC</sub></b> current consumption DC-DC (V <sub>DC</sub> =+15V P <sub>DCDC</sub> =8W)			525		
<b>P<sub>DC-DC</sub></b> power DC-DC SMPS			8		W
<b>V<sub>DD</sub></b> supply voltage electronics	+14	+15	+16	+15V	V
<b>I<sub>DD</sub></b> current draw electronics		8			mA
<b>f<sub>S</sub></b> switching frequency	0		60		kHz
<b>T<sub>pd on</sub></b> signal transition time switch on		670			ns
<b>T<sub>pd off</sub></b> signal transition time switch off		580			ns
<b>t<sub>dif</sub></b> transition time differences		50			ns
<b>t<sub>md</sub></b> Minimal puls suppression		400			ns
<b>d</b> duty cycle	0		100		%
Reference voltage for the V <sub>CE sat</sub> – monitoring <b>V<sub>CEstat</sub></b>	2		9	8 <sup>3)</sup>	V
Threshold logic and signal level (IN A/B; Reset; Mode) <b>V<sub>Level</sub></b>		+8		+15	V
Reactivation after fault condition and IN A/B Low <sup>2)</sup> <b>t<sub>BK</sub></b>	50			60	ms
Interlock delay time in half-bridge mode <b>t<sub>TD</sub></b> <sup>4)</sup>	1,6				µs
Coupling capacity primary/secondary <b>C<sub>ps</sub></b>		18			pF
Coupling capacity sec. channel A to B <b>C<sub>ss</sub></b>		15			pF

1) "Conditions to be defined"

2) See chapter 2.4

3) See chapter 2.7

4) See chapter 2.3

5) See chapter 2.6

Max. switching frequency:

$$f_{S \max.} = \frac{I_{outAV} (mA)}{Q_G (\mu C) \cdot 1,5}$$

f<sub>max</sub> = maximum switching frequency

I<sub>outAV</sub> = average cont. output current per channel

Q<sub>G</sub> = maximum IGBT gate charge at 30V

1.5 = tolerance factor

**1.9 Maximum switching frequency with different module nominal currents IGBT<sup>3</sup>**

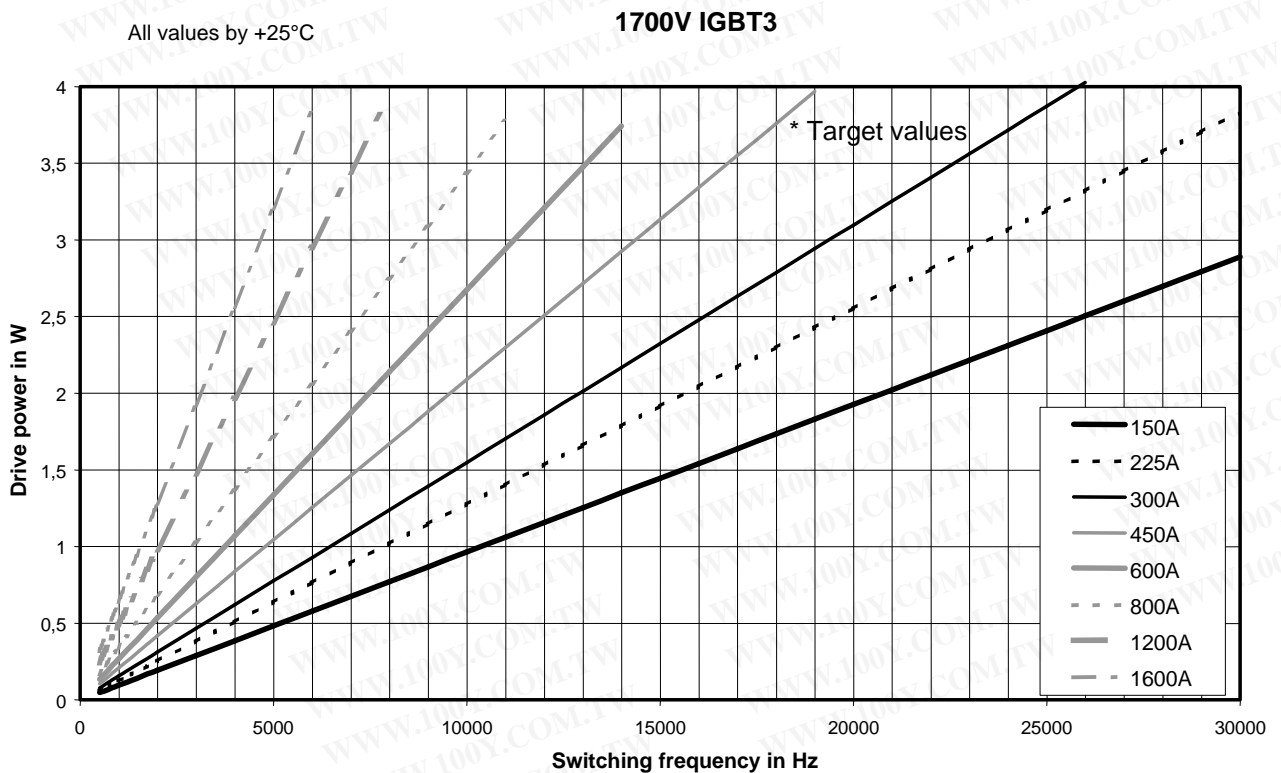
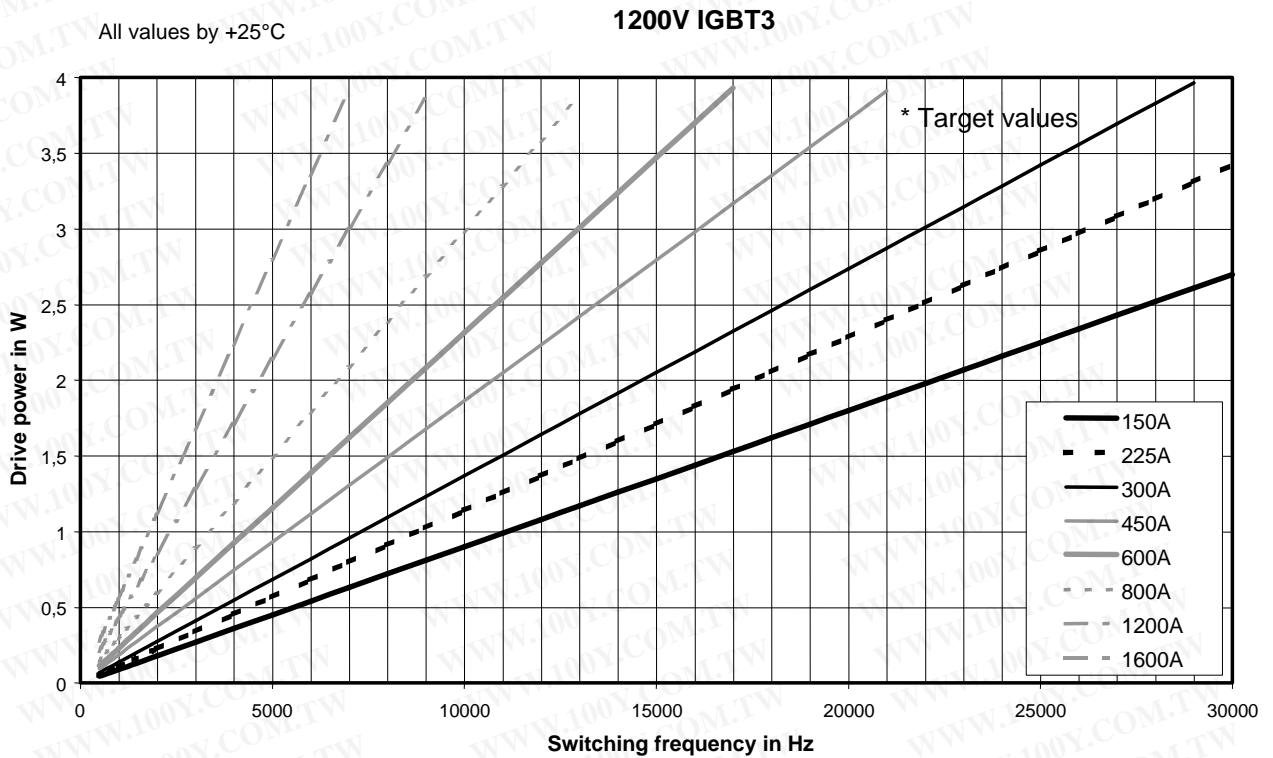

## 1.10 Mechanical dimensions

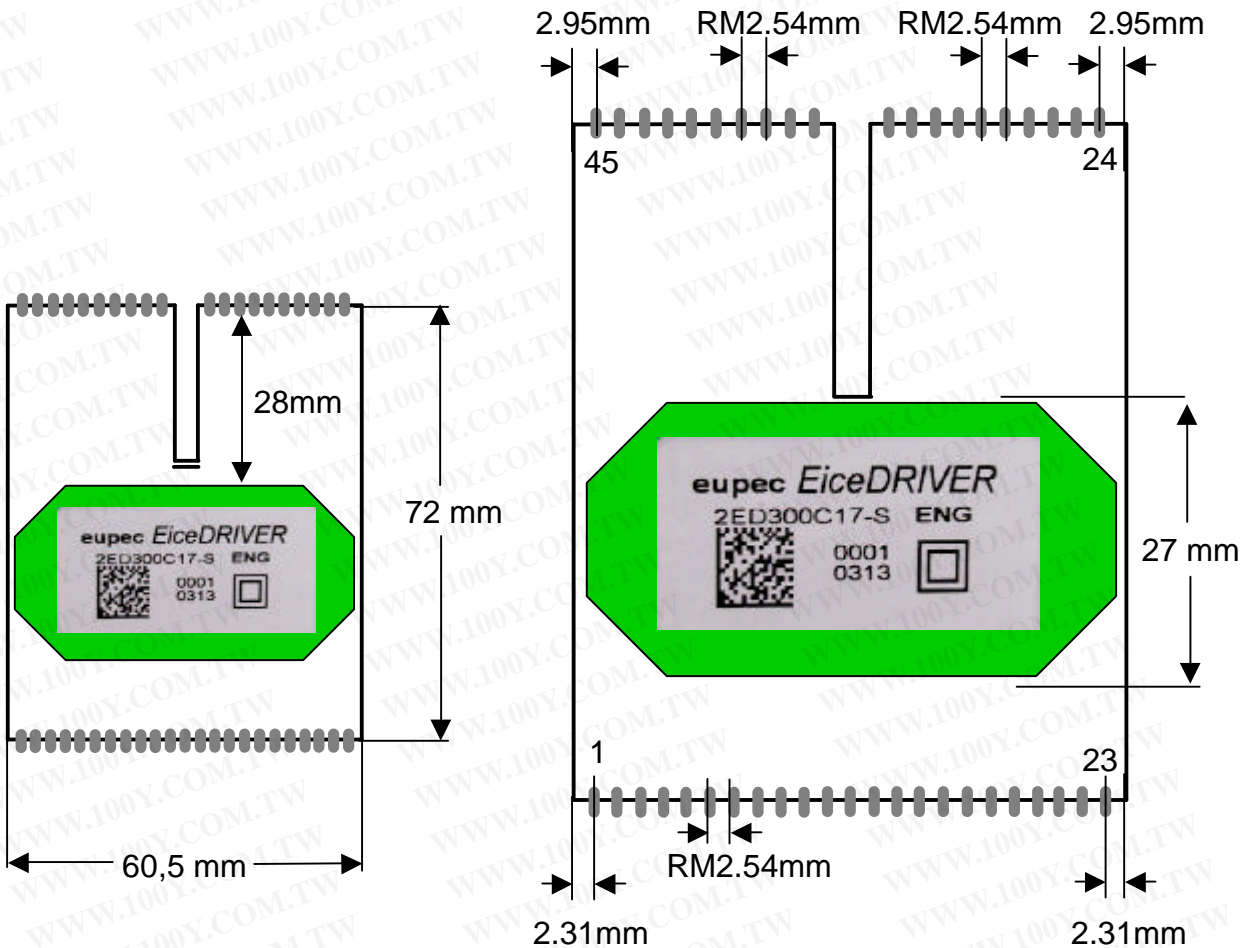

Clearance distance and creep page Primary/ Secondary	>15	mm
Clearance distance Secondary/ Secondary	>6	mm
Creep page Secondary/ Secondary	>14	mm

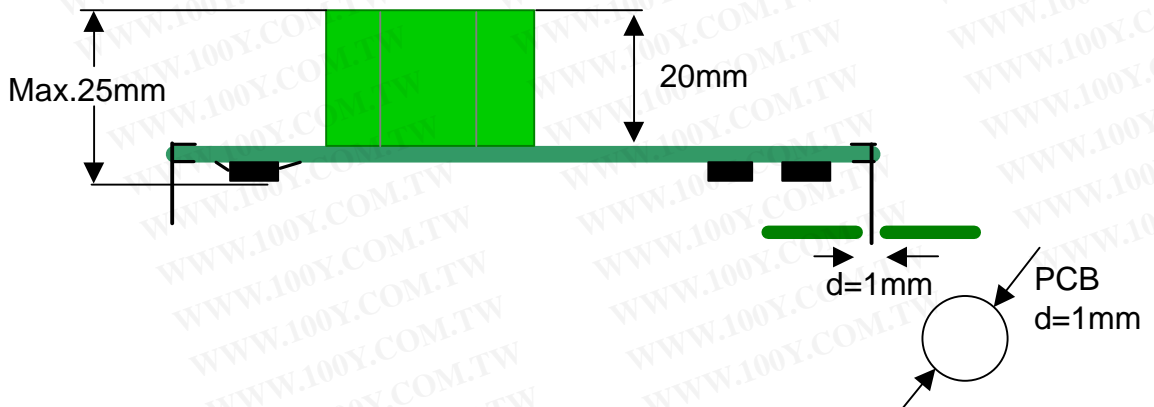

## 2. The transformer

### 2.1 Safe electrical isolation Protection Class II according to EN50178

The safe isolation between primary and secondary side of the two transformers and the switch mode power supply is the basis for the 2ED300C17-S.

Highly insulated coil wires, core insulated ferrites and a special sealing compound (UL94 V-0) are used for this purpose. The design makes sure that all windings are physically separated from each other. There are no overlapping primary and secondary windings. The winding connections are terminated directly to the pins which are cast into the housing. All that is contained in a plastic housing certified to UL 94.

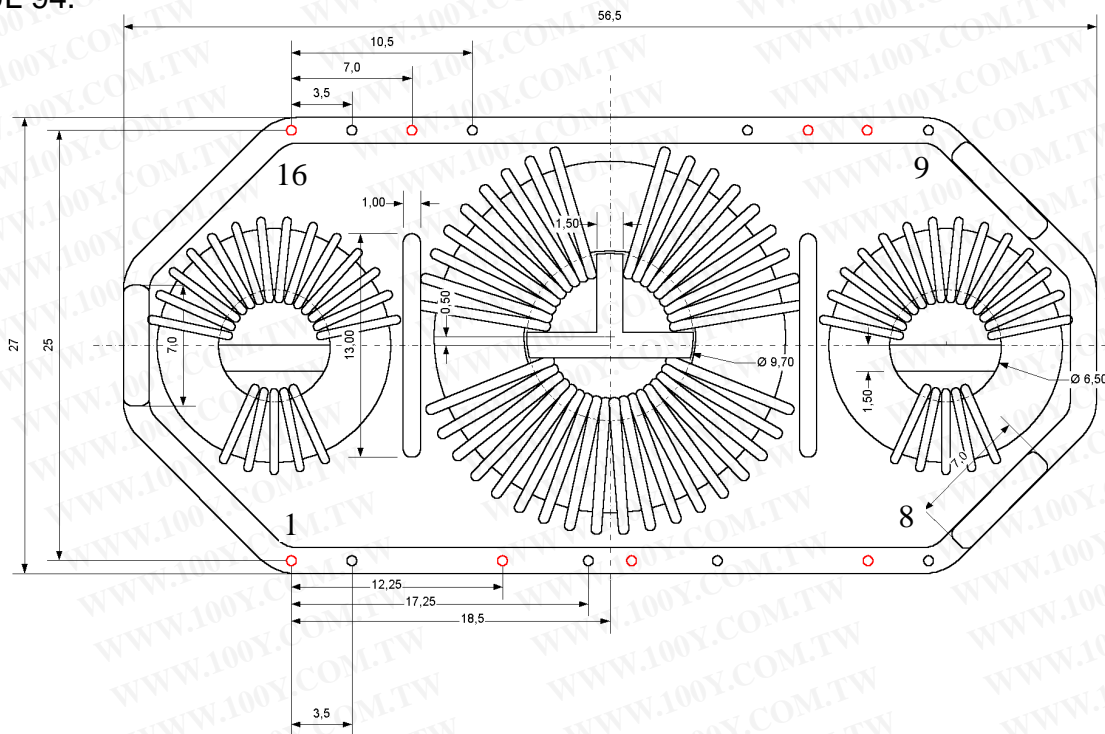

Figure 2.1 Complete transformers with cores in position

The transformer is designed for use in industrial and traction applications. The test voltage applied between all inputs and all outputs is 5kV AC for 1 second. The test voltage applied between the secondaries is 2.25kV AC for 1 second. (EN50178 Table18) (Individual test)

The insulation test is completed by the surge voltage test stipulated by EN50178.

Surge voltage test according to (EN50178 table 17) is 1.5/50 $\mu$ s with 9.6kV.

The partial discharge extinction voltage stipulated by the standard (EN50178 table19) is above 1763V crest value (type test).

## 3 Application of the 2ED300C17-S:

### 3.1 Power supply

The 2ED300C17-S has an integrated DC-DC switch mode inverter, which generates the required secondary voltages. The generated voltages are for the top and bottom channel with +15V primaries each ±16V secondaries.

Hence the 2ED300C17-S only requires one external power supply of +15V. The 2ED300C17-S is operated on a stabilized +15V (±1V) supply. It is distinguished between  $V_{DD}$  and  $V_{DC}$ . All inputs are switched with +15V, where  $V_{DC}$  should be additionally stabilized by a capacitor  $C_{DC}$  (see figure 3.1). This stabilizing capacitor  $C_{DC}$  should be 220µF minimal.

All GND pins have to be connected. To prevent a ground loop there is no internal connection of the DC-DC SMPS ground and the primary electronics.

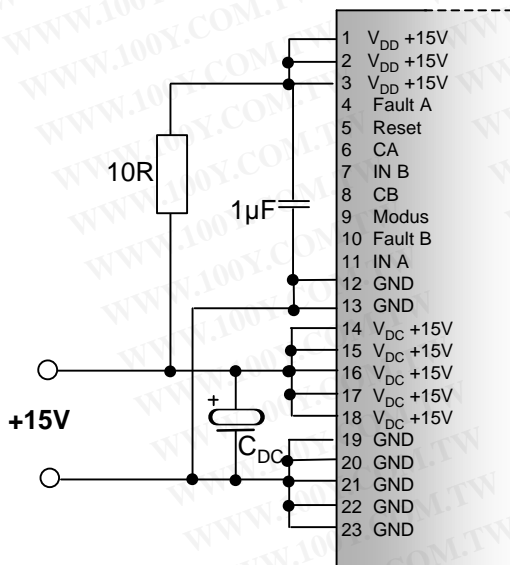

Figure 3.1 Pin configuration of +15V voltage supply

#### Note!

**If the driver is turned on with +15V, a low voltage fault may be tripped depending on the voltage slew rate. This will be reset after 50ms if both signal levels IN A and IN B remain Low during this time.**

#### Note!

**No potential difference greater than 20V may occur between  $V_{DD}$  and  $V_{DC}$ .**

#### Note!

**The 2ED300C17-S features secondary under-voltage monitoring. If the secondary supply voltage drops below typical +12V or -12V, a fault condition will occur which turns off the driver and is transferred to the primary as well.**

### 3.2 Mode selection

The 2ED300C17-S features two operating functions to drive eupec IGBT modules. These are the direct mode and the half-bridge mode.

- The direct mode:

In this mode there is no link between the two channels of the 2ED300C17-S. Both channels IN A and IN B are working independently from each other and may both be turned on at once. The inputs IN A and IN B are switched with +15V PWM signals. The direct mode is activated by taking pin 9 "Mode selection" to GND (e.g.: pin 12/13). The inputs CA pin 6 and CB pin 8 are not connected.

**Note!**

**In the direct mode the inputs CA and CB may not be connected to +15V or GND. For EMC reasons it is recommended to connect the inputs CA and CB with 470pF to GND.**

- The half-bridge mode:

This mode generates an interlock time between the two channels of the 2ED300C17-S. I.e. there is always only one channel active. The interlock time between the switching events may be selected. This is done with the inputs CA pin 6 and CB pin 8.

The half-bridge mode is activated by taking pin 9 "Mode selection" to VDD (pin 1/2/3).

The inputs IN A and IN B are switched with PWM inputs.

Explanation:

There is always only one channel turned on. If there is a high signal on one channel, this is turned on after the interlock time has ended. If during this time there is a high signal for the second channel it will be ignored until the first turned on channel has turned off.

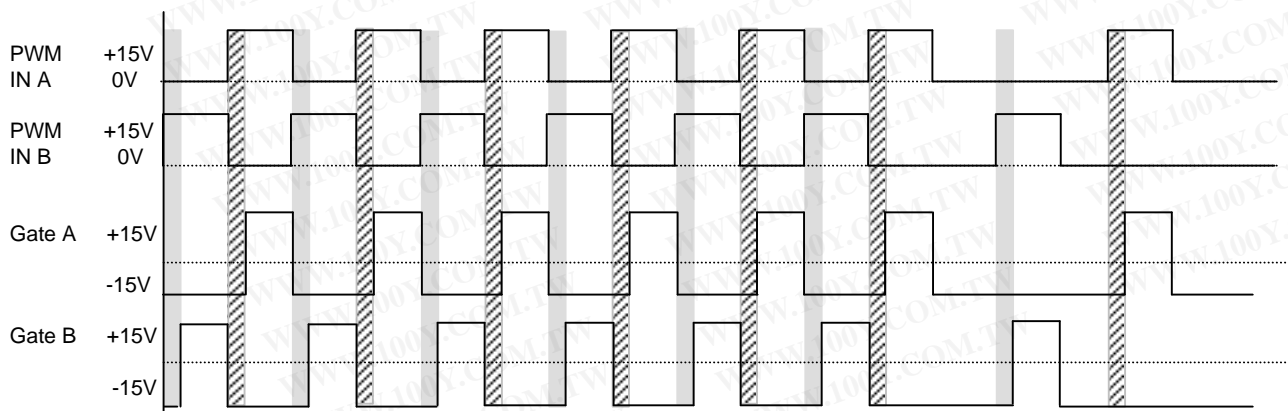

Figure 3.2 Switching diagram with interlock delay times

### 3.3 Interlock delay times

In half-bridge mode the 2ED300C17-S generates a minimal internal interlock delay time between the two channels. This minimal interlock time  $t_{TD}$  is preset to 1,6  $\mu$ s. By adding a capacitance to the two inputs CA and CB this interlock time is extended and adapted to the requirements of the application. The capacitance is externally added between CA and CB to GND (see page 7 – 1.6 Pin configuration).

The capacitance for the required interlock time is derived from the following table:

Del. time $T_{TD}$	CA / CB
1,6 $\mu$ s	n.c.
2 $\mu$ s	47pF
2,4 $\mu$ s	100pF
3,4 $\mu$ s	220pF
4,3 $\mu$ s	330pF
5,4 $\mu$ s	470pF
9,6 $\mu$ s	1nF

**NOTE !**

*It is not permit to connect the inputs CA and CB direct to a voltage potential.*

**NOTE !**

*The tolerance of the interlock delay times depends mainly on the tolerance of the external capacities. This needs to be considered when choosing the capacitors!*

Table 3.3 Interlock delay time settings

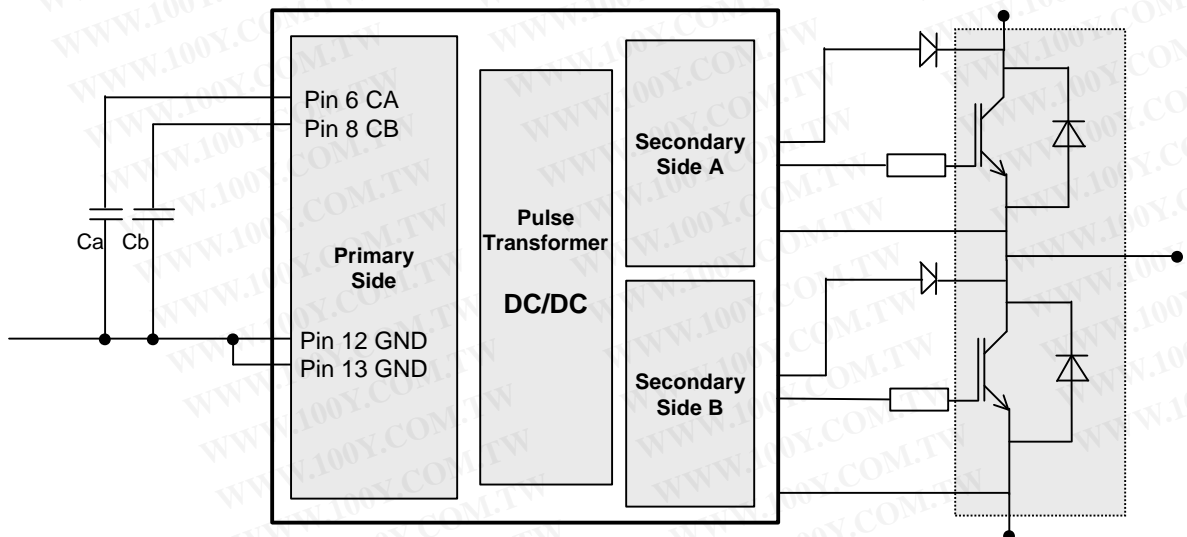

Figure 3.3 Connection of the external capacitors to increase the interlock times

### 3.4 Logic level

The term “logic level” concerns the fault output and the reset input as well as the input for operating mode selection described in chapter 3.2.

- Logic inputs

The two inputs (reset and mode) may be stressed with a maximum voltage of 20V. The switching threshold is at **8V**, so the existing +15V offers itself as switching signal.

**1) Mode:** see chapter 3.2

**2) Reset:** The driver can be reset via the reset input after a fault has been indicated. The reset input is active high, i.e. a **high signal activates the reset**. Logic signal level is by 8V.

If reset is used by the PWM inputs IN A and IN B, the reset input is inactive and pin 5 (Reset) has to be permanently connected to GND

If both PWM signals are “**low**” for more than **39ms** the driver is reset.

- Logic outputs

The driver core recognizes short circuit current faults of the IGBTs and faults of the supply voltage. Additionally the 2ED300C17-S features an external fault input. If a fault is detected through the  $V_{CE\ sat}$  monitoring, an under-voltage or the external fault input, the driver core is immediately turned off. With these faults on the secondary side, the IGBT is shut down via a soft turn-off. Each fault is stored until a reset signal on Pin 5 is present. The reset is also activated when the input signal on both channels is low for more than 39ms.

Indication of a fault occurs in any case via a common fault line on the logic output **FAULT**. The fault is brought out twice via Pin4 and Pin10.

These outputs are configured as open collector. The outputs can operate at up to **20V** and can switch a maximum of **20mA**.

If a fault is recognized the internal transistor switches and pulls the fault output to GND.

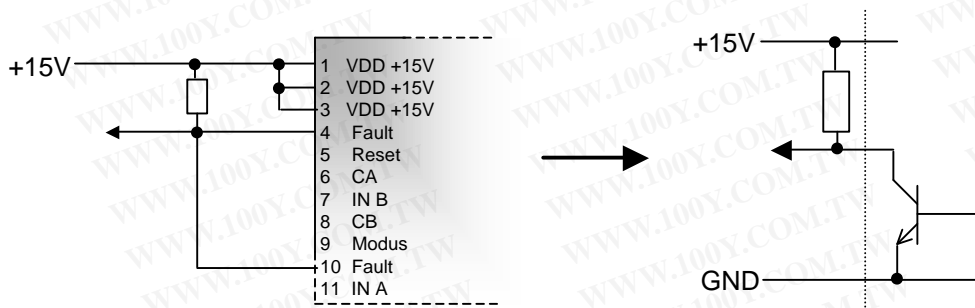

Figure 3.4 Fault output

**Note! The fault outputs are internally connected. There is only one fault output - doubled up.**

### 3.5 Signal level

In both the direct mode and the half-bridge mode the input IN A of the 2ED300C17-S controls channel A, and input IN B controls channel B. The inputs feature a Schmitt-Trigger and an active high logic. A high level turns the IGBT on and a low level turns it off.

The two signal inputs may be operated with a maximum of 20V per channel. Brief negative peaks of equal voltage will not lead to damage of the inputs. **The switching threshold is at +8V to GND.**

The input impedance is **3.3kOhm** for each channel. For long cables it may be necessary to connect an external burst suppression network.

**Note:**

**The 2ED300C17-S features a minimal pulse suppression. Pulses with less than 400ms will be suppressed by the driver.**

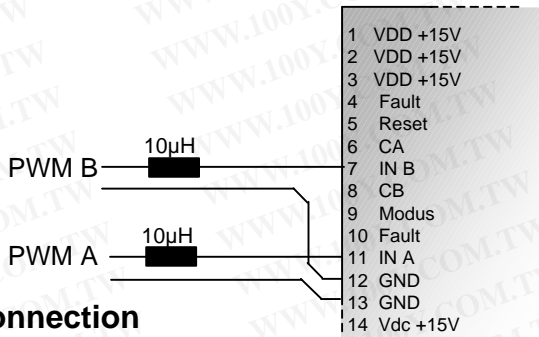

Figure 3.5 Input signal level

### 3.6 IGBT connection

The 2ED300C17-S features two independent channels to drive the IGBTs. It is possible to drive individual IGBTs, single IGBT-modules or IGBT-modules connected in parallel.

The maximum size of the IGBT-modules depends mainly on the IGBT input capacitance and on the switching frequency. This dependency is described on page 9 for KE3 modules.

When considering the gate currents, note that these are not determined by the external gate resistors alone. Many eupec IGBT modules have internal gate resistors (See chapter 5). Additionally, the 2ED300C17-S features a low output impedance. Hence a gate current calculated via the external gate resistor will never be realized in practice. An approximation for the drive power and peak current can be achieved with:

• Driver power

$$P_G = f \cdot \Delta V_{GE}^2 \cdot C_{ies} \cdot 3$$

$$P = P_{DD} + P_G$$

f = switching frequency  
C<sub>ies</sub> = input capacity (datasheet)  
P<sub>DD</sub> = driver dissipation

• Max. driver current

$$I_{G \max} = \frac{\Delta V_{GE}}{R_{G(\min)}}$$

$\Delta V = 30 V \text{ at } \pm 15 V$

$R_{G(\min)} = R_{G \text{ extern}} + R_{G \text{ intern}}$

•Gate connection

The gate of the IGBT is connected to **Gate A** or **Gate B** via the external gate resistor. The associated auxiliary emitter is connected directly to the **COM** outputs. The gate output voltage is  $\pm 15V$  with respect to COM A and COM B (considering chapter 3.1).

By utilizing the external gate resistors it is possible to realize turn-on and turn-off with different gate resistances. Additionally to the gate resistor a gate-emitter resistor and gate clamping should be used. These would be placed between the gate and the aux. emitter. As  $R_{GE}$  a resistor  $< 10k\Omega$  is recommended. The gate clamping is done with Zener diodes or suppressor diodes with a break-over voltage of less than 18V. These diodes prevent the gate voltage to rise to inadmissible levels through parasitic effects (e.g. Miller capacity).

The external gate resistors are defined in the eupec IGBT datasheet.

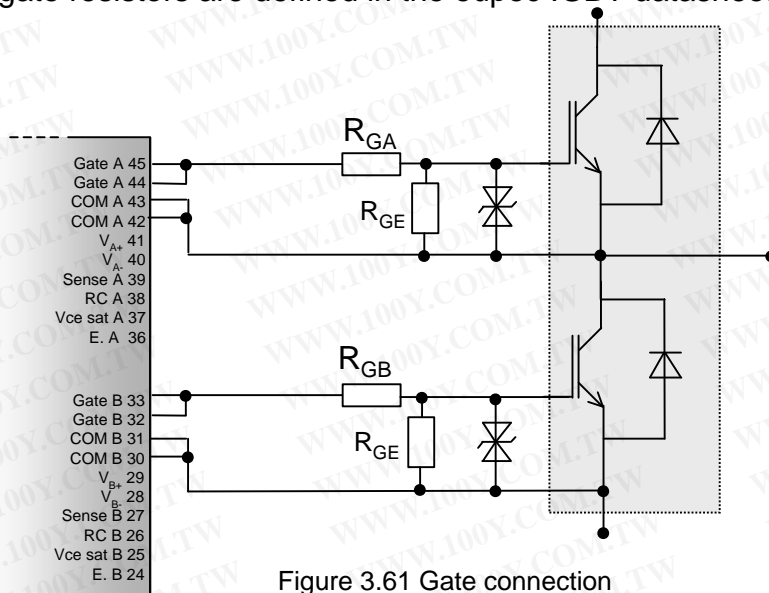

Figure 3.61 Gate connection

**Note!**

*The use of different gate resistors for turn-on and turn-off with field stop IGBTs to change the di/dt (KE3 modules) is not necessary.*

*With field stop IGBTs only the di/dt turn-on behavior is influenced by the gate resistor. See chapter 3.10 "sense". The dv/dt for turn-on and turn-off is still set with the gate resistor.*

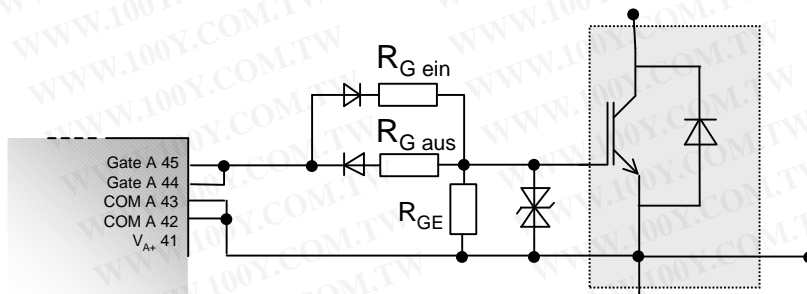

Figure 3.62 Gate connection with  $R_{G\ on}$  and  $R_{G\ off}$

•Collector connection

The 2ED300C17-S is able to measure and evaluate the voltage between collector and emitter of an IGBT. This is used to recognize a short circuit and then shut-down. For the optional function of DVRC or active clamping the connection to the collector is also required.

For the short circuit shut-down function the auxiliary collector is connected to  $V_{CEsat A}$  or  $V_{CEsat B}$ . To block the high DC-link voltage during shut-down a diode  $D_x$  with high reverse blocking voltage has to be connected between the collector and the “Vce sat” input. The reverse blocking capability of these diodes should be higher than the IGBT-module voltage (1200V/1700V). Further the diode has to follow the switching frequency and therefore has to be accordingly fast. Two or three diodes in series is an option to achieve the required blocking capability.

Application and adjustment of the short circuit shut-down is described in detail in the next chapter 3.7.

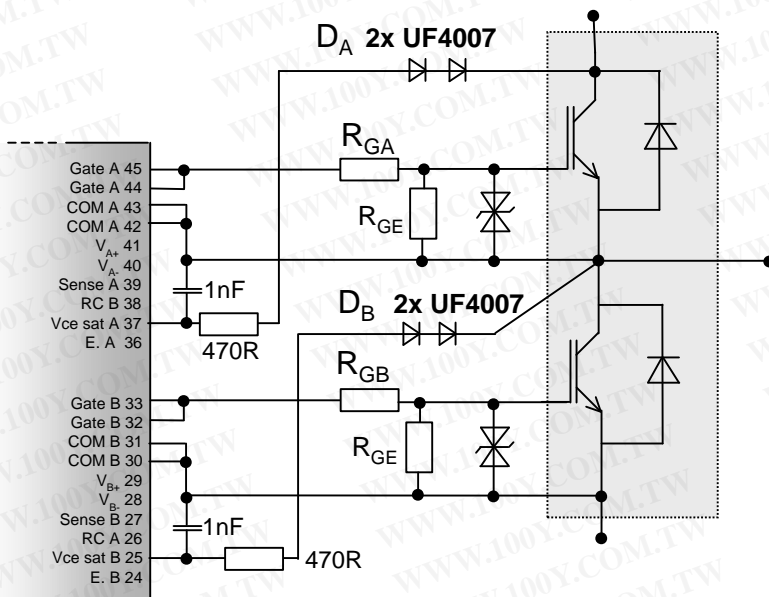

Figure 3.63 Collector connection for  $V_{ce sat}$  measurement

**Note!**

**The  $R_{GE}$ , the gate-emitter clamping diodes, the gate resistor and the collector diodes  $D_x$  should be placed in the closest possible vicinity of the module.**

**Note!**

**If wire links are used between the drivers and the IGBTs the gate lead should be twisted together with the respective emitter and collector leads. Where these connections should be as short as possible. Lengths of more than 20cm are to be avoided.**

### 3.7 IGBT short circuit and over-current shut-down with SSD “soft shut down”

A short circuit or over-current is detected by the integrated  $V_{CE}$  measurement in the 2ED300C17-S (see chapter 3.6). The 2ED300C17-S measures the  $V_{CE}$  voltage while the IGBT is turned on. If the  $V_{CE}$  rises above the preset reference voltage during this period, a fault is triggered and the IGBT is turned off via the internal soft shut-down. For eupec IGBT-modules with NPT and FS-technology the soft shut-down reduces the voltage over-shoot by a slower turn-off.

•The reference curve

is only adjustable via an external  $R_{SX}$  and  $C_{SX}$ . With  $R_{SX}$  the reference voltage is set and with  $C_{SX}$  the reference time.

The resistor and the capacitor are connected between **RC A** and **COM A** or **RC B** and **COM B**. The reference time elapses directly with the turn-on of the respective driver side (See figure 3.7.2)

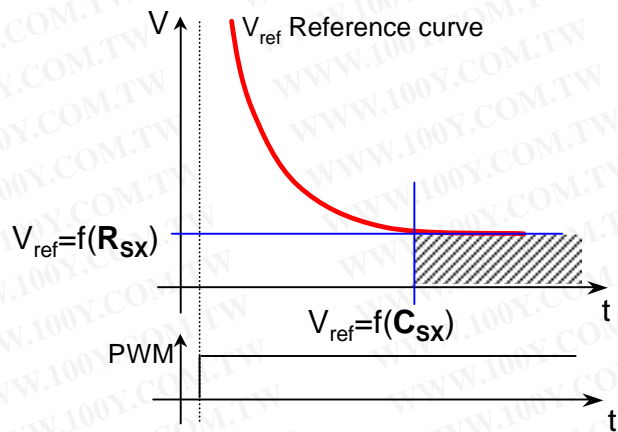
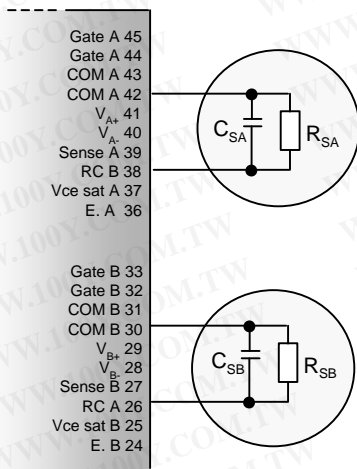

Figure 3.7.2 Reference curve

Figure 3.7.1  $R_{SX}$  and  $C_{SX}$  connection to adjust the reference curve

Reference Voltage $V_{ref}$		$C_{SX}= 0 \text{ pF}$	$C_{SX}= 100 \text{ pF}$	$C_{SX}= 220 \text{ pF}$	$C_{SX}= 470 \text{ pF}$	$C_{SX}= 1 \text{ nF}$
2V	$R_{SX}= 2 \text{ kW}$	0,5µs	1,5 µs	3 µs	5 µs	7
4V	$R_{SX}= 5,4 \text{ kW}$	1 µs	3 µs	4 µs	9 µs	
6V	$R_{SX}= 12 \text{ kW}$	1 µs	4 µs	6 µs		
8V	$R_{SX}= 32 \text{ kW}$	1 µs	5 µs	7 µs		
9V	$R_{SX}= 70 \text{ kW}$	1 µs	5 µs	7 µs		

Table 3.7 gives reference voltage  $V_{ref}$  and reference time  $t_{ref}$  until the reference voltage is reached.

A comparator inside the 2ED300C17-S compares the voltage at the  $V_{CE\ sat}$  input with the reference voltage  $V_{ref}$ . The maximum  $V_{CE}$  voltage at the comparator will be 10V. With the turn-on of the IGBT the  $V_{CE}$  voltage drops to its threshold value depending on the load current  $I_C$ . To suppress commutation effects during turning on the IGBT there is the settable reference curve  $V_{ref}$ . This drops, depending on the external  $C_{SX}$  and  $R_{SX}$  network, from 16V to the set voltage level. If the  $V_{CE}$  voltage rises above the reference voltage at any time, a fault is tripped and the driver is locked.

The various different operating conditions are depicted in the four cases below. If the fault occurs, the IGBT is turned off via the SSD (**S**oft **S**hut **D**own) function.

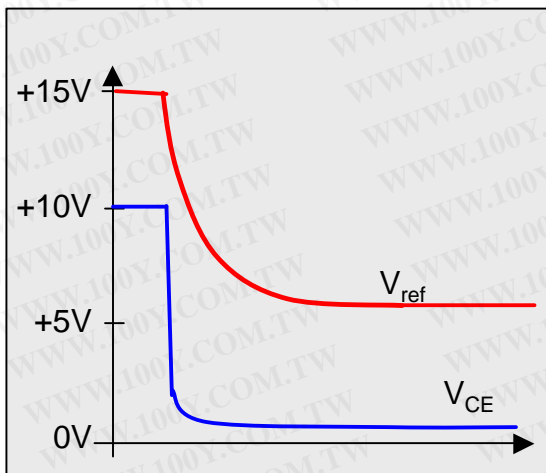

Case 1. Usual case

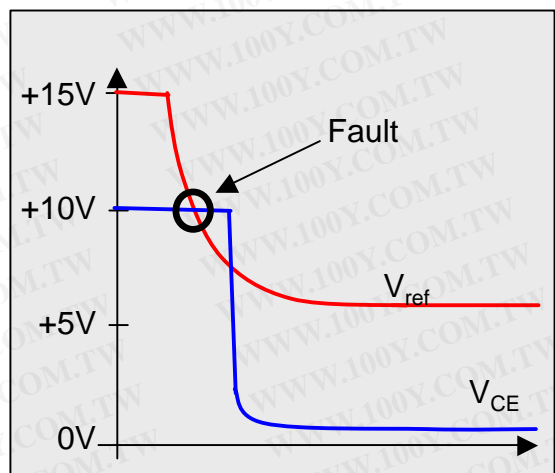

Case 2. IGBT turns on too slowly or reference time is too short

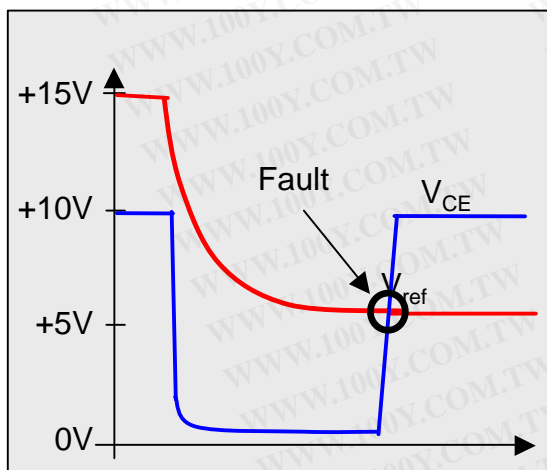

Case 3. Short circuit during operation

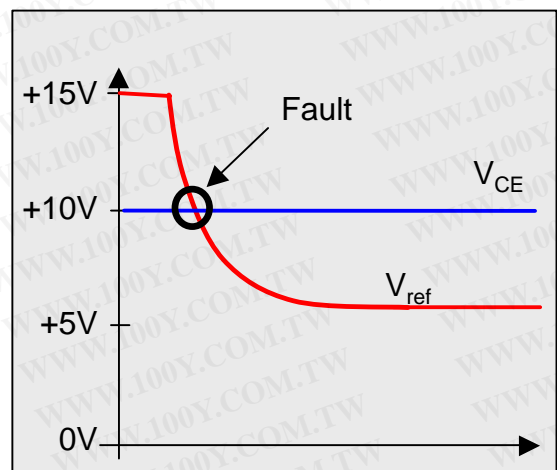

Case 4. Short circuit during turn-on

Figure 3.7.3 Different faults depicted

• Trigger suppression for the  $V_{CE\ sat}$  measurement

To vary the sensitivity of the  $V_{CE}$ , the 2ED300C17-S uses an RC timing network. This network is used to set the sensitivity of the  $V_{CE\ SAT}$  monitoring as required by the individual application. One has to keep in mind that this RC network is a timing function. Accordingly, reaching the reference voltage and in this connection the detection of the temporal short circuit current in the IGBT depend on the charging process of the  $C_{VCE}$  capacitor. This can easily be defined by measuring in front of  $C_{VCE}$  once and in comparison to this  $V_{ce\ sat\ x}$  directly at the input.

The RC combination is able to prolong the operating time till the IGBT switches off in case of a short circuit.

This is to say that in addition to reference time  $t_{reff}$  (table 3.7) and SSD cycle time  $t_{SD}=5\mu s$  and system cycle time  $t_{SD}=1\mu s$ , the trigger suppression time has to be taken into account.

As a standard, a value of  $R_{VCE}=470R$  and  $C_{VCE}=1nF$  is recommended.

Should the  $V_{CE\ sat}$  monitoring react too sensitively the  $C_{VCE}$  value can be increased.

This of course prolongs the trigger time of the short circuit turn-off.

In a contrary case, it is certainly recommended to decrease the  $C_{VCE}$  value or the  $R_{VCE}$  value.

One always has to make sure that the short circuit across the IGBT is switched off after  $10\mu s$ .

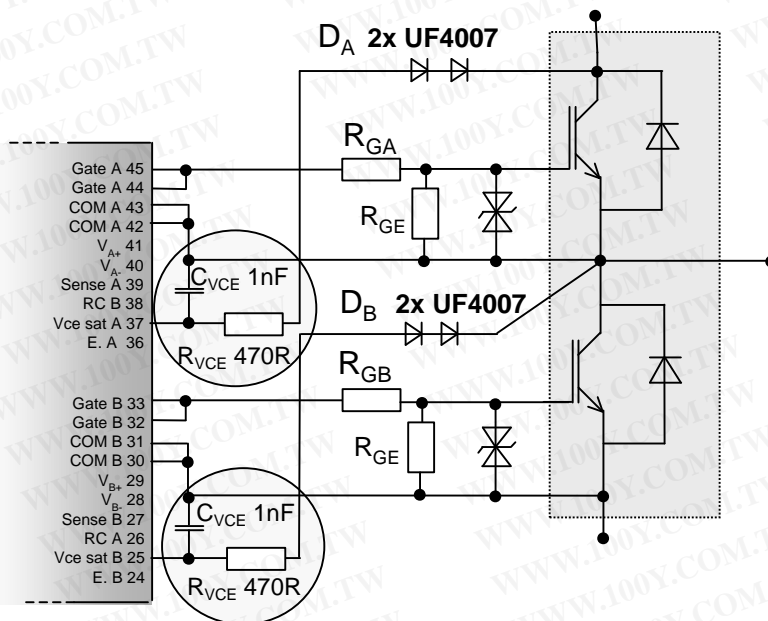

Figure 3.7.4 Trigger suppression of the  $V_{ce\ sat}$  measurement

### 3.8 SSD “Soft Shut Down“

The SSD “Soft Shut Down“ is used to softly shut down the IGBT if a fault occurs. This is sensible in order to avoid destruction of the IGBT due to high voltage overshoots during turn-off. If set correctly the SSD will reduce the turn-off di/dt of all eupec IGBT products and hence the voltage overshoot during fault conditions. The “Soft Shut Down“ is set with resistor  $R_{SSD}$ . This resistor is externally connected between **Sense** and **-16V** (see figure 3.8.1).

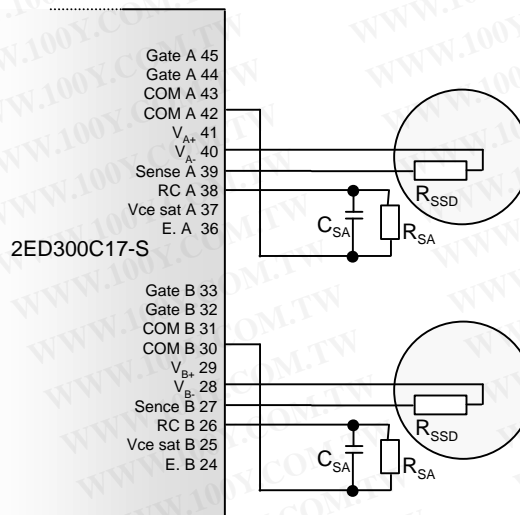

Figure 3.8.1 Connection of  $R_{SSD}$

The “Soft Shut Down“ has to be adapted to the IGBT type used. Since the turn-off behavior and the resulting voltage overshoot depends on the IGBT type and the construction of the entire application, the resistance of the  $R_{SSD}$  resistor has to be found in a practical manner.

As guidance one can use the module **FS450R17KE3** with an  $R_{SSD} = 10k\Omega$ .

IGBT modules with a greater input capacitance  $C_{ies}$  will need a lower  $R_{SSD}$  value, IGBT modules with a lower input capacitance  $C_{ies}$  will need a greater  $R_{SSD}$  value. The dissipation of the resistor is calculated as follows:

$$P_{SSD} [W] = \frac{1024}{R_{SSD}}$$

If a fault is recognized and the “Soft shut down“ is activated, the capacitances of the internal bipolar- output stage go through the charge reversal and thus the IGBT input capacitance  $C_{ies}$  and the Miller capacitance  $C_{res}$  are discharged slowly. This process is limited to  $t_{SD} = 4\mu s$ . After this time the output of 2ED300C17-S turns off hard.

The driver has to be reactivated by a “Reset“ (see chapter 3.4 logic levels).

**Note!**

The “Soft Shut Down” may slightly increase the  $V_{GE}$ . Hence the gate clamping described in chapter 3.6 IGBT Connection has to be observed.

**Note!**

**eupec IGBT modules are generally designed for short circuits of up to  $t_p \leq 10\mu s$ . With the calculation of the external network  $R_{SX}$  and  $C_{SX}$  make sure not to exceed this time.**

$$t_p - t_{SD} - t_{sys} = t_{ref}$$

$t_p$  = short circuit time IGBT  $10\mu s$

$t_{SD}$  = SSD transition time  $5\mu s$

$t_{sys}$  = system transition time  $1\mu s$

$t_{ref}$  = reference time (+ Trigger suppression for the  $V_{ce sat}$ )

**Note!**

The “Soft Shut Down” is not 100% protection from voltage overshoots during fault turn-off!

Should a short circuit occur and at the same time the natural PWM puls go to Low Level the SSD can not be commenced. This case is rare but can occur. Active Clamping will then protect against over-voltage (see 3.10).

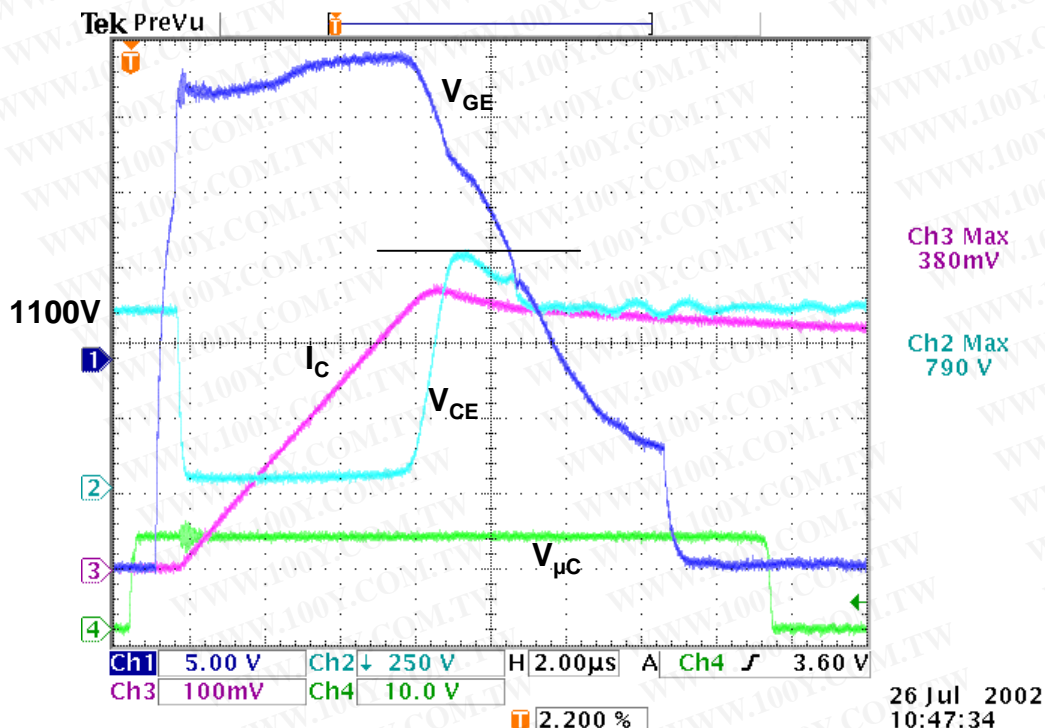

Figure 3.8.2: Short circuit turn-off at 1100V with SSD

The short circuit turn-off depicted in Fig. 3.8.2 clearly shows the course of the Gate-Emitter voltage with SSD.

### 3.9 External fault input

The 2ED300C17-S features an external fault input **E.A** and **E.B**. These are used to set the internal fault memory by a high gate output signal and to trigger a fault. The fault inputs E.A and E.B have an active high logic. Switching level is at 5V, so that a high signal will trigger a fault. The maximum level for the input is  $V_{A+}$  or  $V_{B+}$  referenced to the adjoining COM.

This input is considered for example to detect an over-temperature and/or over-current and so to shut down the driver. **Note that the inputs E.A and E.B may rise up to DC-link potential!**

**Note !**

**If the inputs E.A and/or E.B are not used, they have to be connected to COM A / COM B.**

### 3.10 "Sense" input (SSD "Soft Shut Down", optional DVRC or active clamping)

A special feature of the 2ED300C17-S is the ability to directly manipulate the driver output stage. This is a bipolar output stage externally accessible via the "Sense" input.

This is necessary to limit the voltage overshoot through the di/dt during turn-off of the IGBTs. (see also chapter 3.8 SSD).

With a additional circuit and by using the sense input it is possible to control this di/dt in every operating point during turn-off of the IGBT and hence prevents inadmissibly high turn-off voltage overshoots.

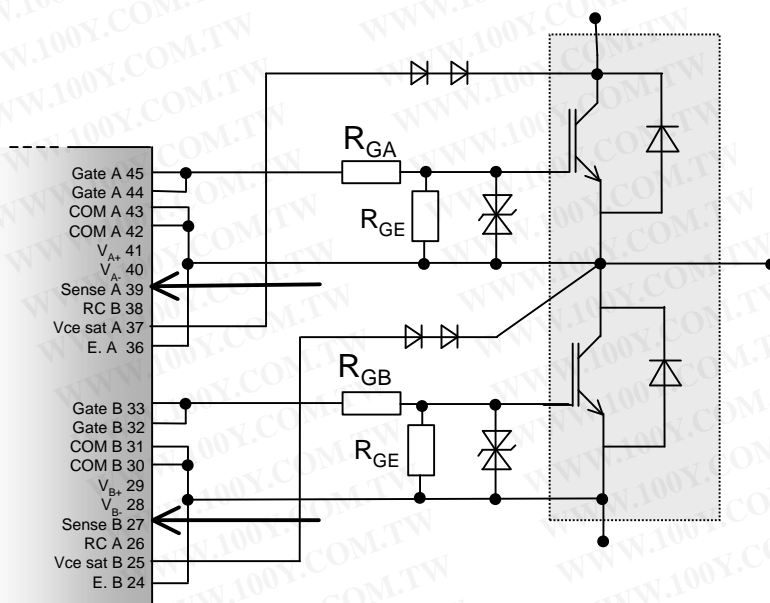

Figure 3.10.1 Utilization of the "Sense" input

A further application of the "Sense" input is the use of an **active clamping\*\*** with direct feedback to the output stage. In this case the Zener diodes used are only minimally loaded which makes for example transile diodes possible.. This can then be combined with an active clamping directly to the gate.

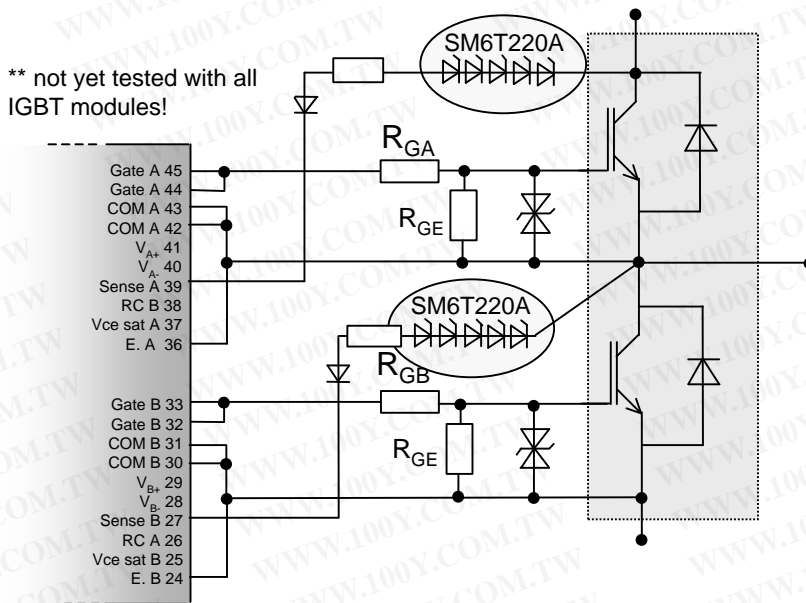

Figure 3.10.2 Utilization of the "Sense" input with active clamping

The standard application with the 2ED300C17-S is the "Soft Shut Down". This is a quasi-linear turn-off during fault condition.. The "Soft Shut Down" has to be adapted to each module type. For this an external resistor  $R_{SSD}$  is connected between "Sense" and  $-16V$ . (See chapter 2.8 Short circuit/over-current turn-off with "Soft shut down" )

**Note!**

**The "Soft shut down" is the standard setting of the 2ED300C17-S. For this a resistor  $R_{SSD}$  should be connected between "Sense and  $-16V$ . If active clamping is used the  $R_{SSD}$  can also be utilized.**

### 3.11 Additional output voltage / buffer capacitors

Depending on the utilization of the internal DC-DC SMPS an additional use of the secondary supply voltage is possible. This is made available on the outputs **+16V** and **-16V** and is referenced to the respective **COM**.

This voltage is potential separated to the primary side. The ground COM is here referenced to the emitter of the respective IGBT.

The outputs **+16V** and **-16V** are also used to connect buffer capacitors  $C_{sup}$ . These prevent voltage drops with high pulse currents.

The buffer capacitors should be placed in closest vicinity to the 2ED300C17-S and **must always be used**.

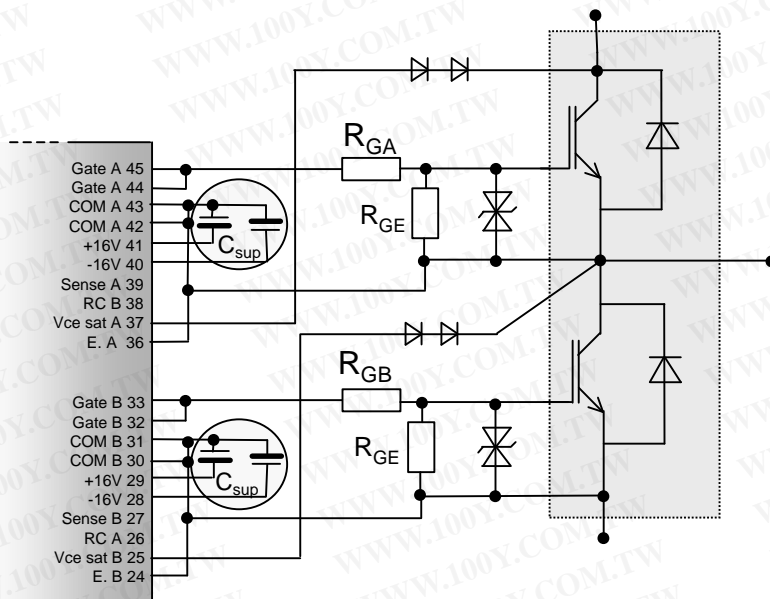

Figure 3.11 2ED300C17-S with external buffer capacitors

**Note!**

The additional electrolytics  $C_{sup}$  always have to be connected. When selecting these capacitors take note of the high ripple current requirement. Meaning, only caps with low impedance are to be used.

# EiceDRIVER™ 2ED300C17-S

## 3.12 Application example 2ED300C17-S

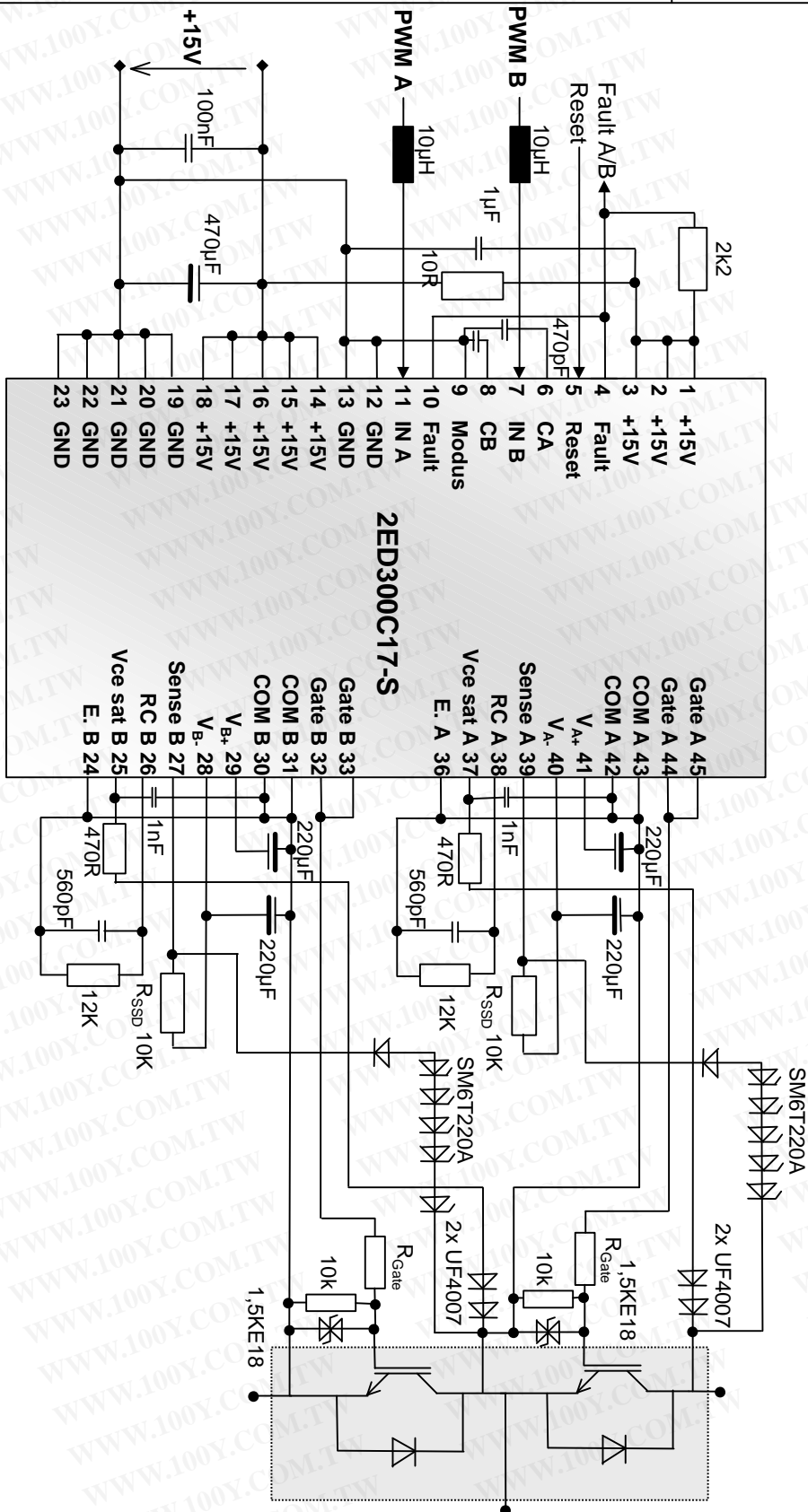

Fig. 3.12 Commissioning circuit in the direct mode:  
(Both channels can be switched independently)

## 4.1 Designations and symbols

<b>C<sub>ps</sub></b>	coupling capacity primary/secondary	<b>R<sub>SX</sub></b>	Reference resistor voltage setting
<b>C<sub>SS</sub></b>	coupling capacity sec. channel A to B	<b>R<sub>VCE</sub></b>	V <sub>CE sat</sub> trigger suppression
<b>C<sub>sup</sub></b>	buffer capacitor	<b>SSD</b>	Soft Shut Down
<b>C<sub>ies</sub></b>	IGBT input capacity	<b>t<sub>TD</sub></b>	interlock delay time
<b>C<sub>ies max</sub></b>	max. admissible IGBT- Gate- capacity	<b>t<sub>TD min</sub></b>	minimum interlock delay time
<b>C<sub>SX</sub></b>	reference capacitor for time setting	<b>t<sub>BK</sub></b>	reactivating time
<b>C<sub>VCE</sub></b>	V <sub>CE sat</sub> trigger suppression	<b>t<sub>dif</sub></b>	transition time difference
<b>COM</b>	reference point	<b>t<sub>md</sub></b>	minimal pulse suppression
<b>d</b>	duty cycle	<b>t<sub>p</sub></b>	short circuit time
<b>DVRC</b>	Dynamic Voltage Rise Control	<b>t<sub>ref</sub></b>	reference time DOCD
<b>DOCD</b>	dynamic over-current detection	<b>t<sub>sd</sub></b>	transition time SSD
<b>dv/dt</b>	voltage slew rate	<b>t<sub>sys</sub></b>	system transition times
<b>di/dt</b>	current rise time	<b>t<sub>pd</sub></b>	signal transition time
<b>EDFA</b>	logic external fault input	<b>T<sub>op</sub></b>	operating temperature
<b>f<sub>s</sub></b>	switching frequency	<b>T<sub>stg</sub></b>	storage temperature
<b>f<sub>s max</sub></b>	max. admissible switching frequency	<b>V<sub>Level</sub></b>	logic switching level
<b>I<sub>c</sub></b>	IGBT collector current	<b>V<sub>DD</sub></b>	supply voltage electronics primary
<b>I<sub>DC</sub></b>	current draw DC-DC	<b>V<sub>DC</sub></b>	primary DC/DC supply voltage
<b>I<sub>DD</sub></b>	current draw electronics	<b>V<sub>iH</sub></b>	maximum voltage of the logic levels
<b>I<sub>G</sub></b>	output peak current	<b>V<sub>iHS</sub></b>	switching threshold logic signals
<b>I<sub>G on</sub></b>	output peak current "On"	<b>V<sub>in</sub></b>	signal input voltage
<b>I<sub>G off</sub></b>	output peak current "Off"	<b>V<sub>isol</sub></b>	isolation test voltage
<b>I<sub>0</sub></b>	Quiescent current	<b>V<sub>isol IO</sub></b>	isolation test input- output
<b>I<sub>OC</sub></b>	logic signal output current	<b>V<sub>isol 12</sub></b>	isolation test output A- output B
<b>I<sub>out</sub></b>	output current of V <sub>A,B±</sub>	<b>V<sub>isol Su</sub></b>	surge test voltage input- output
<b> I<sub>G</sub> <sub>AV</sub></b>	summed average gate current	<b>V<sub>CE</sub></b>	IGBT collector- emitter voltage
<b> I<sub>out</sub> <sub>AV</sub></b>	summed average output current	<b>V<sub>CE sat</sub></b>	IGBT saturation voltage
<b>I<sub>DC max</sub></b>	maximum primary current draw	<b>V<sub>CE stat</sub></b>	V <sub>CE sat</sub> monitoring reference voltage
<b>P<sub>DC/DC</sub></b>	peak output power	<b>V<sub>ref</sub></b>	reference voltage of the DOCD
<b>P<sub>SSD</sub></b>	power of the SSD resistor	<b>V<sub>GE</sub></b>	Gate- Emitter voltage
<b>P<sub>DD</sub></b>	driver power dissipation	<b>V<sub>A;B+</sub></b>	secondary positive voltage
<b>P<sub>G</sub></b>	maximum gate power dissipation	<b>V<sub>A;B-</sub></b>	secondary negative voltage
<b>Q<sub>G</sub></b>	Max.IGBT gate charge at 15V		
<b>R<sub>g</sub></b>	Gate resistor		
<b>R<sub>g min</sub></b>	Minimum gate resistor		
<b>R<sub>g intern</sub></b>	IGBT Chip internal gate resistor		
<b>R<sub>g extern</sub></b>	IGBT external gate resistor (Datasheet)		
<b>R<sub>GE</sub></b>	Gate- Emitter resistor		
<b>R<sub>SSD</sub></b>	Soft Shut Down resistor		

## 4.2 Internal module gate resistor $R_{G \text{ intern}}$

FP10R12KE3	0 Ohm		FF150R12KE3 G	5 Ohm
FP15R12KE3	0 Ohm		FF200R12KE3	3.75 Ohm
FP25R12KE3	8 Ohm		FF300R12KE3	2.5 Ohm
FP40R12KE3	6 Ohm		FD200R12KE3	3.75 Ohm
FP50R12KE3	4 Ohm		FD300R12KE3	2.5 Ohm
FP75R12KE3	10 Ohm		DF200R12KE3	3.75 Ohm
FS25R12KE3	8 Ohm		DF300R12KE3	2.5 Ohm
FS35R12KE3	6 Ohm		FZ300R12KE3	2.5 Ohm
FS50R12KE3	4 Ohm		FZ400R12KE3	1.875 Ohm
FS75R12KE3	10 Ohm		FZ600R12KE3	1.25 Ohm
FS100R12KE3	7.5 Ohm		FF600R12KE3	1.25 Ohm
FS150R12KE3	5 Ohm		FF800R12KE3	0.94 Ohm
FS150R12KE3 G	1.33Ohm		FF1200R12KE3	0.62 Ohm
FS225R12KE3	3.33 Ohm		FZ1200R12KE3	0.62 Ohm
FS300R12KE3	2.5 Ohm		FZ1600R12KE3	0.46 Ohm
FS450R12KE3	1.66 Ohm		FZ2400R12KE3	0.3 Ohm
			FZ3600R12KE3	0.2 Ohm

Table 4.2.1  $R_{G \text{ intern}}$  KE3 1200V modules

FS150R17KE3G	3.17 Ohm			
FS225R17KE3	2.83 Ohm			
FS300R17KE3	2.5 Ohm			
FS450R17KE3	1.67 Ohm			
FF200R17KE3ENG	2.375 Ohm			
FF300R17KE3ENG	2.13 Ohm			
FZ400R17KE3ENG	1.19 Ohm			
FZ600R17KE3ENG	1.06 Ohm			

Table 4.2.2  $R_{G \text{ intern}}$  KE3 1700V modules

BSM50GD120DN2G	5 Ohm		BSM200GB120DLC	2,5 Ohm
FS75R12KS4	5 Ohm		BSM300GB120DLC	1 Ohm
BSM75GD120DLC	5 Ohm		FF100R12KS4	2,5 Ohm
BSM75GD120DN2	5 Ohm		FF150R12KS4	2,5 Ohm
BSM100GD120DN2	5 Ohm		FF200R12KS4	2,5 Ohm
BSM100GD120DLC	5 Ohm		BSM200GA120DN2	1,25 Ohm
FS100R12KS4	5 Ohm		BSM200GA120DN2S	1,25 Ohm
BSM100GT120DN2	5 Ohm		BSM300GA120DN2	1,25 Ohm
BSM150GT120DN2	2,5 Ohm		BSM300GA120DN2S	1,25 Ohm
BSM200GT120DN2	2,5 Ohm		BSM300GA120DN2E3166	1,25 Ohm
BSM150GT120DLC	2,5 Ohm		BSM400GA120DN2	1,25 Ohm
BSM200GT120DLC	1 Ohm		BSM400GA120DN2S	1,25 Ohm
BSM100GAL120DN2	2,5 Ohm		BSM200GA120DLC	1,25 Ohm
BSM150GAL120DN2	2,5 Ohm		BSM200GA120DLCS	1,25 Ohm
BSM200GAL120DN2	2,5 Ohm		BSM300GA120DLC	1,25 Ohm
BSM100GAR120DN2	2,5 Ohm		BSM300GA120DLCS	1,25 Ohm
BSM150GAR120DN2	2,5 Ohm		BSM400GA120DLC	1,25 Ohm
BSM200GAR120DN2	2,5 Ohm		BSM400GA120DLCS	1,25 Ohm
			BSM600GA120DLC	0,5 Ohm
			BSM600GA120DLCS	0,5 Ohm
BSM300GAR120DLC	1 Ohm		FZ800R12KL4C	0,31 Ohm
BSM150GAL120DLC	2,5 Ohm		FZ1200R12KL4C	0,31 Ohm
BSM200GAL120DLC	2,5 Ohm		FZ1600R12KL4C	0,31 Ohm
BSM300GAL120DLC	1 Ohm		FZ1800R12KL4C	0,21 Ohm
			FZ2400R12KL4C	0,21 Ohm
FF400R12KF4	0,62 Ohm			
FF600R12KF4	0,62 Ohm			
FF800R12KF4	0,62 Ohm		FS300R12KF4	1,25 Ohm
FF400R12KL4C	0,62 Ohm		FS400R12KF4	
FF600R12KL4C	0,62 Ohm		FD400R12KF4	1,25 Ohm
FF800R12KL4C	0,62 Ohm		FD600R12KF4	0,63 Ohm
			F4-400R12KF4	1,25 Ohm
FZ800R12KS4	0,56 Ohm		F4-400R12KS4_B2	1,25 Ohm
FZ800R12KF4	0,56 Ohm			
FZ1050R12KF4	0,61 Ohm			

Table 4.2.3  $R_{G \text{ intern}}$  1200V Modul

FF400R17KF6C_B2	1,53 Ohm		FZ1200R17KF6C_B2	0,76 Ohm
FF600R17KF6_B2	1,53 Ohm		FZ1600R17KF6_B2	0,62 Ohm
FF800R17KF6C_B2	1,25 Ohm		FZ1600R17KF6C_B2	0,62 Ohm
FZ800R17KF6C_B2	0,76 Ohm		FZ1800R17KF6_B2	0,67 Ohm
FZ1200R17KF6_B2	0,76 Ohm		FZ2400R17KF6C_B2	0,67 Ohm
			FD600R17KF6_B2	1,53 Ohm
			FD600R17KF6C_B2	1,53 Ohm
			FD800R17KF6_B2	0,76 Ohm

Table 4.2.4  $R_{G \text{ intern}}$  1700V Modul

## 4.3 Type designation

**EiceDRIVER™ eupec IGBT controlled efficiency DRIVER**

For example: **2ED300C17-S**

**Isolation class:**

- F = funktion isolation
- S = safety isolation
- ST= safety isolation/ Traction

**Voltage class:**

- 06 = 600V
- 12 = 1200V
- 17 = 1700V und 1200V
- 33 = 3300V
- 65 = 6500V

**Driver type:**

- C = Driver core with DC/DC
- E = Evaluation board
- I = Driver IC (Coreless Transformer)
- L = Driver IC (Level shifter)

**Maximum output current:**

- For example
- 004 = 0.4 A
  - 020 = 2.0 A
  - 300 = 30.0 A

**eupec IGBT driver**

**Driver channels**

- 1 = single driver
- 2 = halfbride driver
- 6 = SixPACK driver

勝特力材料 886-3-5753170  
 勝特力电子(上海) 86-21-34970699  
 勝特力电子(深圳) 86-755-83298787  
[Http://www.100y.com.tw](http://www.100y.com.tw)