

Power Semiconductors Shortform Catalog 2003

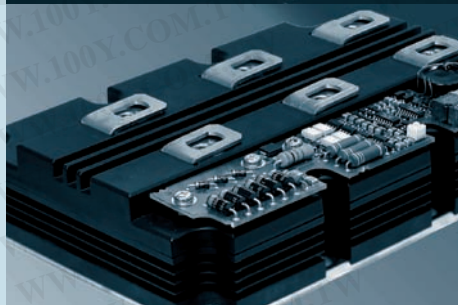
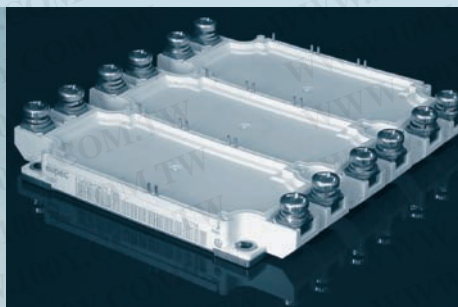
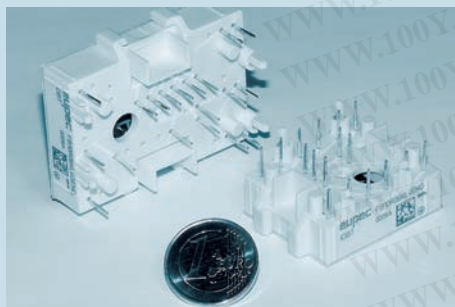
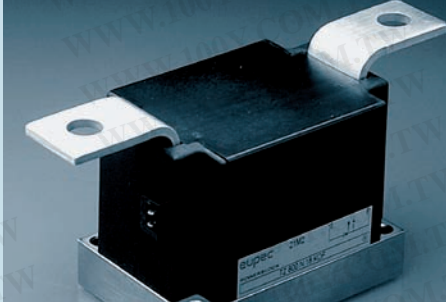

eupec

勝特力材料 886-3-5753170
勝特力电子(上海) 86-21-34970699
勝特力电子(深圳) 86-755-83298787
[Http://www.100y.com.tw](http://www.100y.com.tw)

eupec

eupec Inc. headquartered in Lebanon, New Jersey, provides a wide array of innovative semiconductor products, including IGBT high power and standard modules, thyristors and diodes.

Quality products and service coupled with our unsurpassed technical expertise, furnish customers with a complete and superior source for all of their semiconductor requirements.

eupec Inc.'s local inventory capability allows for compliance with customers' most stringent delivery requirements by utilizing programs such as WEB pull, JIS, EDI and KANBAN.

Value added abilities such as special lead assemblies and hardware, customized markings, and bar coding are also offered. eupec is an ISO 9001 certified company.

eupec Inc. emphasizes the importance of meeting each customer's individual project requirements. From early technical planning to prompt on-time delivery of products, eupec Inc. welcomes the opportunity to be your „partner“ in all your semiconductor needs.

eupec Inc. serves the American market through a comprehensive network of direct sales-people, representatives and distributors, covering the United States, Canada and Latin America.

eupec Inc.'s exceptional product line, technical experience and unsurpassed customer support mirrors eupec Inc.'s primary objective – our customer's success.

eupec Inc. Sales Offices

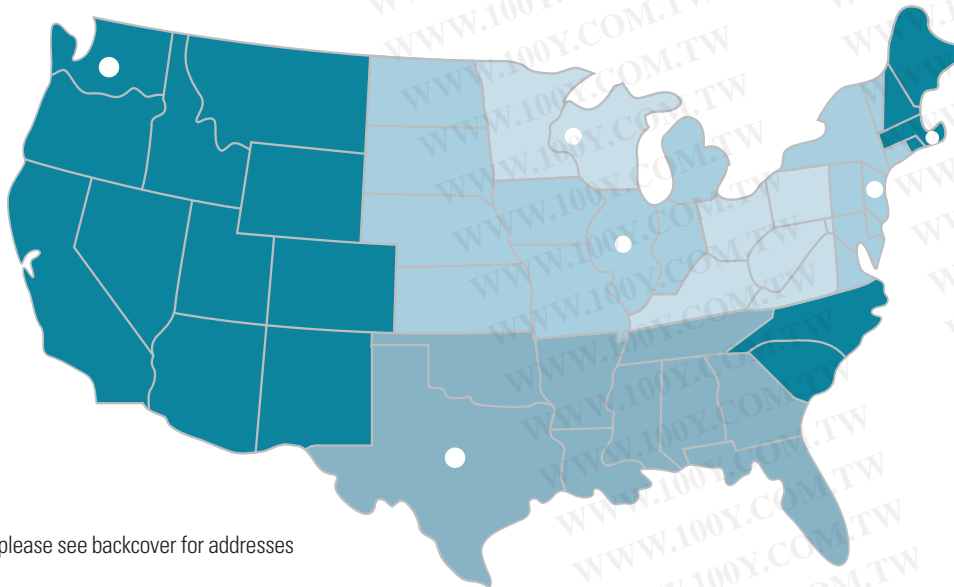

please see backcover for addresses

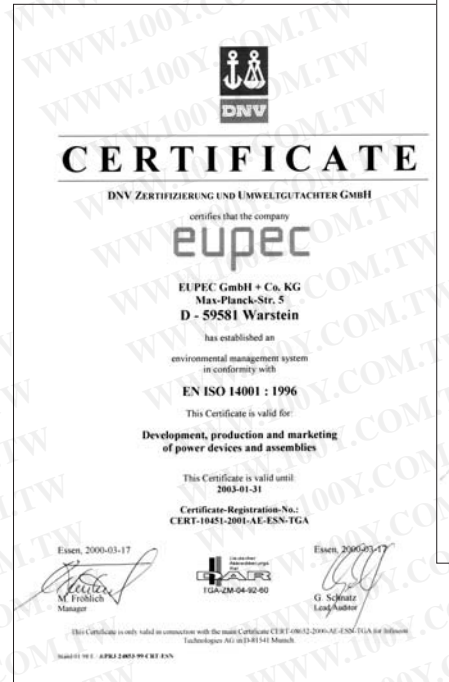

We feel committed to protect the environment and the natural resources. Our measures in designing in an environmental-protective way include the production sequences of operations as well as the complete product spectrum. Our environment management system is certified according to DIN EN ISO 14001. Our quality management is permanently brought in line with the requests and expectations of our customers, partners and employees. It is improved continuously and regularly tested for its efficiency according to the international standards of QS9000 and the EFQM model for Business Excellence.

The Quality Management of eupec fullfills the requirement of DIN ISO 9001 thus being certified by DQS, the German Company for certification of quality management systems. Absolute reliability is guaranteed in every respect. This means: Customers play the most important role and it is our main target to fulfill their demands.

Content

Page

eupec Presentation	2
Certificate ISO 9001	2
Certificate ISO 14001	2
IGBT	4
<i>Overview IGBT</i>	4
IGBT High Power Modules	5
Diode Modules	7
IGBT Standard Modules	9
Single Diodes	11
Power Integrated Modules PIM	12
Easy PIM/PACK	13
EconoPACK +	14
Drivers for IGBT's	15
IGBT Driver Boards	15
SCR/Diode Modules	16
IsoPACK Bridge Rectifier & AC-Switches	16
EconoBRIDGE Rectifier	17
<i>Overview PowerBLOCK Thyristor Modules</i>	18
PowerBLOCK Thyristor Modules	19
PowerBLOCK Single Thyristor Modules	20
<i>Overview PowerBLOCK Thyristor/Diodes Modules</i>	21
PowerBLOCK Thyristor/Diode Modules	22
<i>Overview PowerBLOCK Diodes/Thyristor Modules</i>	23
PowerBLOCK Diode/Thyristor Modules	24
<i>Overview PowerBLOCK Diode Modules</i>	25
PowerBLOCK Rectifier Diode Modules	26
PowerBLOCK Thyristor Diode Modules for current source Inverters	27
PowerBLOCK Fast Thyristor Modules	28
PowerBLOCK Fast Asymmetric Thyristor Modules	29
PowerBLOCK Fast Diode Modules	30

Content

Page

Presspacks	31
Freewheeling Diodes	31
Snubber Diodes	32
Pulsed Power Applications	32
Traction Crow Bar	32
<i>Overview Thyristors in Disc Housings</i>	33
Thyristors	34
Fast Thyristors	39
Fast Asymmetric Thyristors	42
<i>Overview Diodes in Disc Housings</i>	43
Diodes	44
Fast Diodes	47
Avalanche Diodes	49
Welding Diodes	49
Insulated Cells	49
Stacks	50
Possible Combinations of Presspacks and Heatsinks	50
Outlines Heatsinks	51
Outlines	60
Accessories	90
Gate Leads for Thyristor Modules	90
Mounting Hardware for Modules	90
Standard Gate Leads for Disc Type Devices	91
Explanations	92
Clamping Force and Disc Diameter	92
Letter Symbols	94
Type Designations	95
eupec Addresses	96

Complete technical specifications are available in PDF format on eupec's Data CD Rom and on our website: www.eupec.com

Overview IGBT's

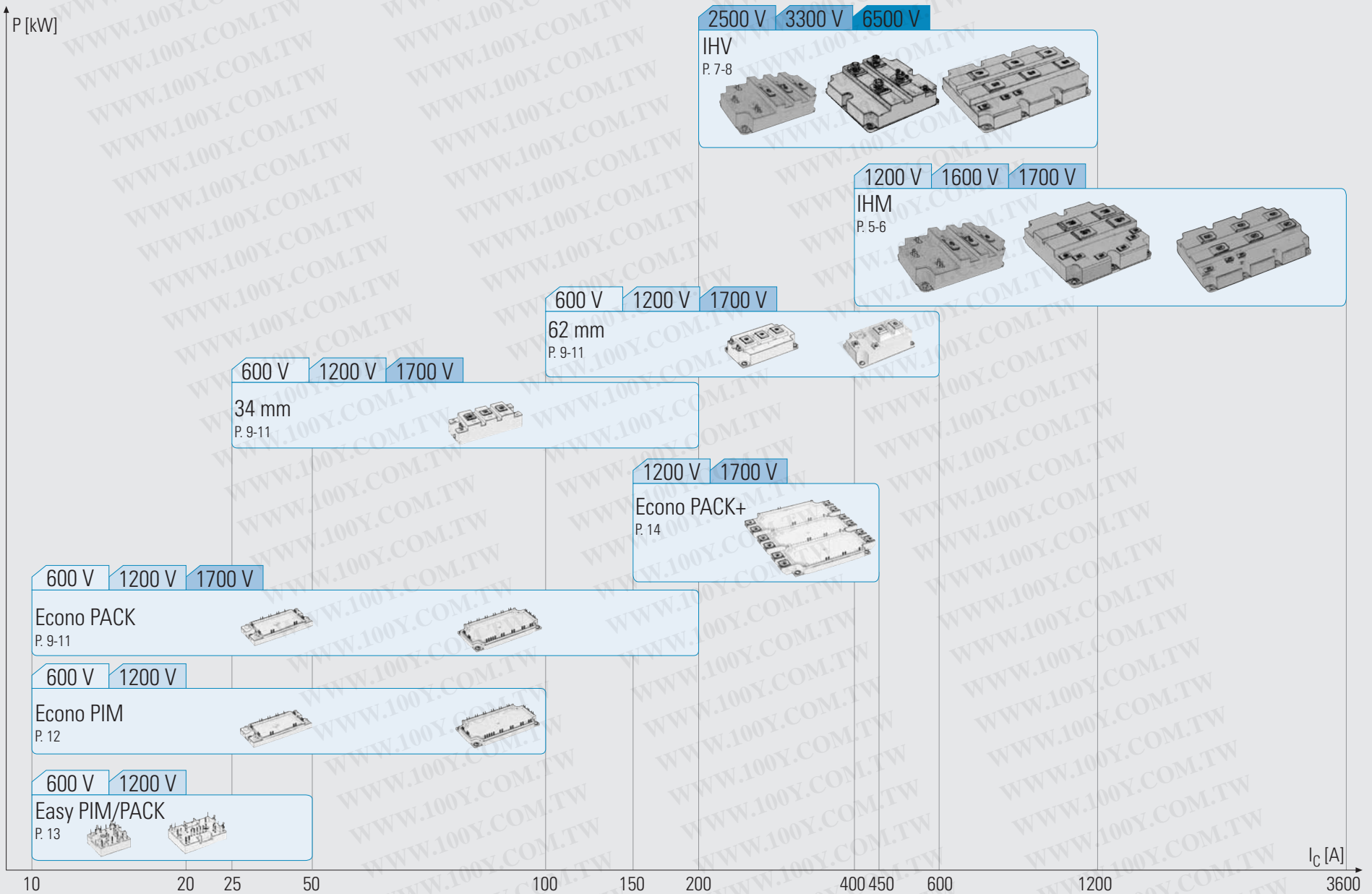

IGBT High Power Modules

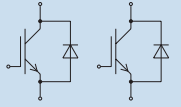
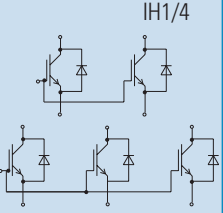

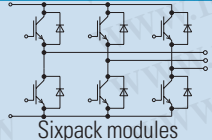
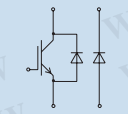
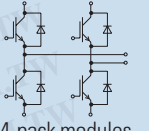
1200 V _{CES}		V _{CES} V	I _c A	V _{CESat} V T _{vj} =25°C typ.	E _{on} /E _{off} mWs T _{vj} =125°C typ.	R _{thJC} °K/W per arm	outline / page
Type *)							
 Dual modules	Standard 2. Generation						
	FF400R12KF4	1200	400	2,7	70/60	0,046	IH2/60
	FF600R12KF4	1200	600	2,7	90/90	0,032	IH2/60
	FF800R12KF4	1200	800	2,7	130/120	0,025	IH2/60
	Low Loss 2. Generation						
	FF400R12KL4C	1200	400	2,1	72/58	0,044	IH2/60
	FF600R12KL4C	1200	600	2,1	100/90	0,032	IH2/60
	FF800R12KL4C	1200	800	2,1	120/130	0,025	IH2/60
	IGBT3						
	◆ FF600R12KE3	1200	600	1,7	100/95	0,044	IH2/60
◆ FF800R12KE3	1200	800	1,7	135/130	0,032	IH2/60	
◆ FF1200R12KE3	1200	1200	1,7	200/190	0,025	IH2/60	
 Single modules	Short Tail						
	FZ800R12KS4	1200	800	3,0	76/64	0,018	IH4/60
	Standard 2. Generation						
	FZ800R12KF4	1200	800	2,7	130/120	0,023	IH1/60
	FZ1050R12KF4	1200	1050	2,7	150/170	0,018	IH1/60
	FZ1200R12KF4	1200	1200	2,7	170/190	0,016	IH1/60
	FZ1600R12KF4	1200	1600	2,7	220/290	0,0125	IH1/60
	FZ1800R12KF4	1200	1800	2,7	250/330	0,011	IH7/61
	FZ2400R12KF4	1200	2400	2,7	310/410	0,0084	IH7/61
	Low Loss 2. Generation						
	FZ800R12KL4C	1200	800	2,1	121/127	0,022	IH1/60
	FZ1200R12KL4C	1200	1200	2,1	165/195	0,016	IH1/60
	FZ1600R12KL4C	1200	1600	2,1	210/260	0,0125	IH1/60
	FZ1800R12KL4C	1200	1800	2,1	230/295	0,0110	IH7/61
	FZ2400R12KL4C	1200	2400	2,1	320/400	0,0084	IH7/61
	IGBT3						
	◆ FZ1200R12KE3	1200	1200	1,7	200/190	0,022	IH4/60
	◆ FZ1600R12KE3	1200	1600	1,7	265/250	0,016	IH4/60
	◆ FZ2400R12KE3	1200	2400	1,7	400/380	0,0125	IH4/60
	◆ FZ3600R12KE3	1200	3600	1,7	600/570	0,008	IH7/61

1200 V _{CES}		V _{CES} V	I _c A	V _{CESat} V T _{vj} =25°C typ.	E _{on} /E _{off} mWs T _{vj} =125°C typ.	R _{thJC} °K/W per arm	outline / Page
Type *)							
 Sixpack modules	Standard 2. Generation						
	FS300R12KF4	1200	300	2,7	80/45	0,064	IH8/61
	FS400R12KF4	1200	400	2,7	100/55	0,048	IH8/61
 Chopper modules	Standard 2. Generation						
	FD400R12KF4	1200	400	2,7	70/60	0,046	IH2/60
 4-pack modules	Standard 2. Generation						
	F4-300R12KF4	1200	300	2,7	80/45	0,064	IH5/60
	F4-400R12KF4	1200	400	2,7	100/55	0,050	IH5/60
	Short Tail						
	F4-400R12KS4_B2	1200	400	3,0	38/32	0,042	IH5/60

- ◆ New type
- Not for new design

*) valid for all part-no:
T_{vj} = 125°C, I_{CRM} = 2xI_c

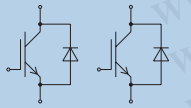
IGBT High Power Modules

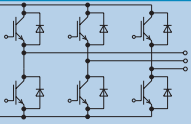
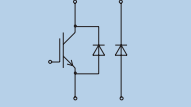
1600 V _{CES}							
Type *)	V _{CES} V	I _C A	V _{CEsat} V T _{vj} =25°C typ.	E _{on} /E _{off} mWs T _{vj} =125°C typ.	R _{thJC} °K/W per arm	outline / page	
 Dual modules	Standard 2. Generation FF400R16KF4	1600	400	3,3	170/90	0,04	IH2/60
	FF600R16KF4	1600	600	3,5	240/140	0,032	IH2/60
IH1  Single modules	Standard 2. Generation FZ800R16KF4	1600	800	3,3	340/180	0,02	IH1/60
	FZ1200R16KF4	1600	1200	3,5	490/290	0,016	IH1/60
	FZ1800R16KF4	1600	1800	3,5	750/450	0,011	IH7/61
 Six pack modules	Standard 2. Generation FS300R16KF4	1600	300	3,5	120/70	0,064	IH8/61
 Chopper modules	Standard 2. Generation FD400R16KF4	1600	400	3,3	170/90	0,04	IH2/60
	FD600R16KF4	1600	600	3,5	240/140	0,032	IH2/60

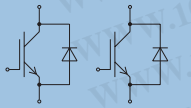
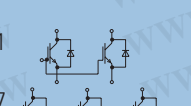
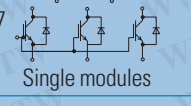
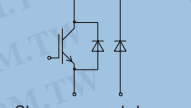
1700 V _{CES}							
Type *)	V _{CES} V	I _C A	V _{CEsat} V T _{vj} =25°C typ.	E _{on} /E _{off} mWs T _{vj} =125°C typ.	R _{thJC} °K/W per arm	outline / page	
 Dual modules	Low Loss FF400R17KF6C_B2	1700	400	2,7	180/150	0,016	IH2/60
	FF401R17KF6C_B2	1700	400	2,7	200/150	0,04	IH9/61
	FF600R17KF6C_B2	1700	600	2,7	270/220	0,026	IH2/60
	FF800R17KF6C_B2	1700	800	2,7	290/335	0,02	IH2/60
IH1  Single modules	Low Loss FZ800R17KF6C_B2	1700	800	2,7	300/325	0,02	IH1/60
	FZ1200R17KF6C_B2	1700	1200	2,7	330/480	0,013	IH1/60
	FZ1600R17KF6C_B2	1700	1600	2,7	430/670	0,01	IH1/60
	FZ1800R17KF6C_B2	1700	1800	2,7	570/725	0,009	IH7/61
 Single modules	FZ2400R17KF6C_B2	1700	2400	2,7	750/1060	0,007	IH7/61
 Chopper modules	Low Loss FD401R17KF6C_B2	1700	400	2,7	200/150	0,04	IH9/61
	FD600/1200R17KF6_B2	1700	600	2,7	270/220	0,026	IH2/60
	FD600R17KF6C_B2	1700	600	2,7	270/220	0,016	IH2/60
	FD800R17KF6C_B2	1700	800	2,7	290/335	0,02	IH2/60

- ◆ New type
- Not for new design

*) valid for all part-no:
T_{vj} = 125°C, I_{CRM} = 2xI_C

IGBT High Power Modules

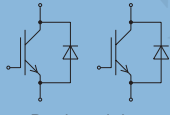
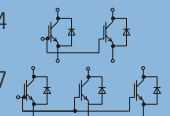
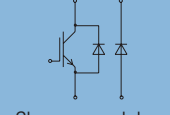
2500 + 3300 V _{CES}		Type *)	V _{CES} V	I _c A	V _{CESat} V T _{vj} =25°C typ.	E _{on} /E _{off} mWs T _{vj} =125°C typ.	R _{thJC} °K/W per arm	outline/ page
 Dual modules	Standard							
	FF200R33KF2	3300	200	3,4	480/255	0,057	IH9/61	
	FF400R33KF2	3300	400	3,4	960/510	0,026	IH6/61	
	FF500R25KF1	2500	500	3	650/500	0,024	IH6/61	
	Low Loss							
FF400R33KL2	3300	400	3,1		0,026	IH6/61		
 Single modules	Standard							
	FZ800R33KF2	3300	800	3,4	1920/1020	0,013	IH4/60	
	FZ1000R25KF1	2500	1000	3	1300/1000	0,012	IH4/60	
	FZ1200R33KF2	3300	1200	3,4	2880/1530	0,0085	IH7/61	
	FZ1500R25KF1	2500	1500	3	1900/1500	0,008	IH7/61	
	Low Loss							
	FZ800R33KL2	3300	800	3,1		0,013	IH4/60	
FZ1200R33KL2	3300	1200	3,1		0,0085	IH7/61		
 Chopper modules	Standard							
	FD400R33KF2	3300	400	3,4	960/510	0,026	IH4/60	
	FD400R33K2-K	3300	400	3,1			IH4/60	
	FD800R33KF2	3300	800	3,4	1920/1020	0,013	IH7/61	

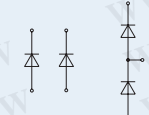
Diode Modules		Type *)	V _{RRM} V	I _F A	I _R mA typ.	Q _r µAs typ.	R _{thJC} °K/W per arm	outline/ page
 Diode Modules		DD400S16K4	1600	400	15	40	0,1	IH1/60
		DD600S16K4	1600	600	40	60	0,08	IH1/60
		DD400S17K6C_B2	1700	400	5	145	0,016	IH1/60
		DD401S17K6C_B2	1700	400	10	160	0,07	IH9/61
		DD600S17K6_B2	1700	600	8	170	0,05	IH1/60
		DD800S17K6C_B2	1700	800	10	265	0,034	IH1/60
		Standard						
		DD200S33K2	3300	200	1	220	0,108	IH9/61
		DD400S33K2	3300	400	2	440	0,051	IH4/60
		DD800S33K2	3300	800	4	900	0,025	IH4/60
	DD1200S33K2	3300	1200	6	1320	0,017	IH4/60	
	Low Loss							
	DD1200S33KL2	3300	1200				IH4/60	
	DD800S33KL2	3300	1200				IH4/60	
	DD400S33KL26	3300	400				IH4/60	
	DD400S33KL2	3300	400				IH9/61	

- ◆ New type
- Not for new design

*) valid for all part-no:
T_{vj} = 125°C, I_{CRM} = 2xI_C

IGBT High Power Modules

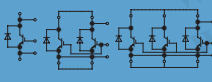
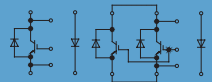
6500 V _{CES}		Type *)	V _{CES} V	I _c A	V _{CESat} V T _{vj} =25°C	E _{on} /E _{off} mWs T _{vj} =125°C	R _{thJC} °K/W per arm	outline / page
	Standard							
	FZ200R65KF1	6500	200	4,3	1900/1200	0,033	IH10/62	
	FZ400R65KF1	6500	400	4,3	4000/2300	0,017	IH11/62	
	FZ600R65KF1	6500	600	4,3	5900/3500	0,011	IH12/62	
Single modules								
	Standard							
	FD200R65KF1-K	6500	200	4,3	1900/1200	0,033	IH11/62	
	FD400R65KF1-K	6500	400	4,3	4000/2300	0,017	IH12/62	
Chopper modules								

Diode Modules		Type *)	V _{RRM} V	I _F A	I _R mA typ.	Q _r μAs typ.	R _{thJC} °K/W per arm	outline / page
		DD200S65K1	6500	200	15	350	0,063	IH11/62
		DD400S65K1	6500	400	15	700	0,032	IH11/62
		DD600S65K1	6500	600	20	1050	0,021	IH11/62
Diode Modules								

- ◆ New type
- Not for new design

*) valid for all part-no:
T_{vj} = 125°C, I_{CRM} = 2xI_C

IGBT Standard Modules

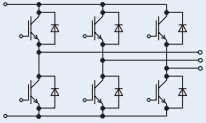
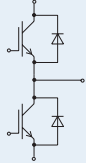

600 V – Type							
Type	V_{CES} V	I_C A	V_{CEsat} V $T_{vj}=25^\circ\text{C}$ typ.	P_{tot} W	R_{thJC} K/W \leq per arm	outline / page	
 3-Phase- Full-Bridges	Standard						
	BSM20GD60DLC	600	20	1,95	125	1,6	IS2/63
	BSM20GD60DLCE3224	600	20	1,95	125	1,6	IS3/63
	BSM30GD60DLC	600	30	1,95	135	1,2	IS2/63
	BSM30GD60DLCE3224	600	30	1,95	135	1,2	IS3/63
	BSM50GD60DLC	600	50	1,95	250	0,6	IS3/63
	BSM50GD60DLCE3226	600	50	1,95	250	0,6	IS2/63
	BSM75GD60DLC	600	75	1,95	330	0,44	IS3/63
	BSM100GD60DLC	600	100	1,95	430	0,35	IS8/64
	BSM150GD60DLC	600	150	1,95	570	0,24	IS8/64
BSM200GD60DLC	600	200	1,95	700	0,18	IS8/64	
 Half-Bridges	Standard						
	BSM50GB60DLC	600	50	1,95	280	0,6	IS4/63
	BSM75GB60DLC	600	75	1,95	355	0,44	IS4/63
	BSM100GB60DLC	600	100	1,95	445	0,35	IS4/63
	BSM150GB60DLC	600	150	1,95	595	0,24	IS4/63
	BSM200GB60DLC	600	200	1,95	730	0,18	IS4/63
BSM300GB60DLC	600	300	1,95	1250	0,12	IS5a/63	

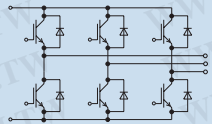
- ◆ New type
- Not for new design

1200 V – Type								
Type	V_{CES} V	I_C A	V_{CEsat} V $T_{vj}=25^\circ\text{C}$ typ.	P_{tot} W	R_{thJC} K/W \leq per arm	outline / page		
 3-Phase- Full-Bridges	Standard 2. Generation							
	BSM10GD120DN2	1200	10	2,7	80	1,52	IS2/63	
	BSM10GD120DN2E3224	1200	10	2,7	80	1,52	IS3/63	
	BSM15GD120DN2	1200	15	2,5	145	0,86	IS2/63	
	BSM15GD120DN2E3224	1200	15	2,5	145	0,86	IS3/63	
	BSM25GD120DN2	1200	25	2,5	200	0,6	IS2/63	
	BSM25GD120DN2E3224	1200	25	2,5	200	0,6	IS3/63	
	BSM35GD120DN2	1200	35	2,7	280	0,44	IS2/63	
	BSM35GD120DN2E3224	1200	35	2,7	280	0,44	IS3/63	
	BSM50GD120DN2	1200	50	2,5	350	0,35	IS3/63	
	BSM50GD120DN2E3226	1200	50	2,5	350	0,35	IS2/63	
	BSM50GD120DN2G	1200	50	2,5	400	0,35	IS8/64	
	BSM75GD120DN2	1200	75	2,5	520	0,239	IS8/64	
	BSM100GD120DN2	1200	100	2,5	680	0,182	IS8/64	
	Low Loss 2. Generation							
		BSM15GD120DLCE3224	1200	15	2,1	145	0,96	IS3/63
		BSM25GD120DLCE3224	1200	25	2,1	200	0,6	IS3/63
		BSM35GD120DLCE3224	1200	35	2,1	280	0,44	IS3/63
		BSM50GD120DLC	1200	50	2,1	350	0,35	IS3/63
		BSM75GD120DLC	1200	75	2,1	500	0,24	IS8/64
BSM100GD120DLC		1200	100	2,1	650	0,182	IS8/64	
IGBT3								
	◆ FS25R12KE3G	1200	25	1,7	150	0,8	IS3a/63	
	◆ FS35R12KE3G	1200	35	1,7	200	0,60	IS3a/63	
	◆ FS50R12KE3	1200	50	1,7	270	0,45	IS3a/63	
	◆ FS75R12KE3	1200	75	1,7	350	0,35	IS3a/63	
	◆ FS75R12KE3G	1200	75	1,7	350	0,35	IS8a/64	
	◆ FS100R12KE3	1200	100	1,7	500	0,25	IS8a/64	
◆ FS150R12KE3	1200	150	1,7	650	0,19	IS8a/64		
Short Tail								
	FS75R12KS4	1200	75	3,2	500	0,25	IS8/64	
FS100R12KS4	1200	100	3,2	610	0,19	IS8/64		

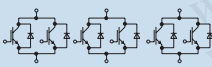
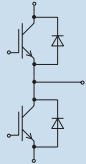
IGBT Standard Modules

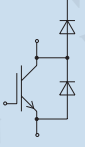
1200 V – Type		V_{CES} V	I_C A	V_{CEsat} V $T_{vj}=25^\circ\text{C}$ typ.	P_{tot} W	R_{thJC} K/W \leq per arm	outline / page	
 Tripack	Standard 2. Generation							
	BSM100GT120DN2	1200	100	2,5	680	0,182	IS9/64	
	BSM150GT120DN2	1200	150	2,5	1250	0,12	IS9/64	
	BSM200GT120DN2	1200	200	2,1	1400	0,09	IS9/64	
	Low Loss 2. Generation							
	BSM150GT120DLC	1200	150	2,1	1000	0,125	IS9/64	
BSM200GT120DLC	1200	200	2,1	1300	0,095	IS9/64		
 Half-Bridges	Standard 2. Generation							
	BSM25GB120DN2	1200	25	2,5	200	0,6	IS4/63	
	BSM35GB120DN2	1200	35	2,7	280	0,44	IS4/63	
	BSM50GB120DN2	1200	50	2,5	400	0,3	IS4/63	
	BSM75GB120DN2	1200	75	2,5	625	0,2	IS4/63	
	BSM100GB120DN2K	1200	100	2,5	700	0,18	IS4/63	
	BSM100GB120DN2	1200	100	2,5	800	0,16	IS5a/63	
	BSM150GB120DN2	1200	150	2,5	1250	0,1	IS5a/63	
	BSM200GB120DN2	1200	200	2,5	1400	0,09	IS5a/63	
	Low Loss 2. Generation							
	BSM35GB120DLC	1200	35	2,1	340	0,44	IS4/63	
	BSM50GB120DLC	1200	50	2,1	460	0,35	IS4/63	
	BSM75GB120DLC	1200	75	2,1	690	0,24	IS4/63	
	BSM100GB120DLCK	1200	100	2,1	830	0,18	IS4/63	
	BSM100GB120DLC	1200	100	2,5	780	0,16	IS5a/63	
	BSM150GB120DLC	1200	150	2,1	1200	0,1	IS5a/63	
	BSM200GB120DLC	1200	200	2,1	1300	0,09	IS5a/63	
	BSM300GB120DLC	1200	300	2,1	2500	0,05	IS5a/63	
	IGBT3							
	◆ FF150R12KE3G	1200	150	1,7	780	0,16	IS5a/63	
	◆ FF200R12KE3	1200	200	1,7	1040	0,12	IS5a/63	
	◆ FF300R12KE3	1200	300	1,7	1470	0,085	IS5a/63	
	Short Tail							
	FF100R12KS4	1200	100	3,2	780	0,16	IS5a/63	
FF150R12KS4	1200	150	3,2	1200	0,1	IS5a/63		
FF200R12KS4	1200	200	3,2	1400	0,09	IS5a/63		
◆ FF300R12KS4	1200	300	on request	on request	on request	IS5a/63		

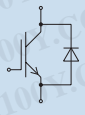
1200 V – Type		V_{CES} V	I_C A	V_{CEsat} V $T_{vj}=25^\circ\text{C}$ typ.	P_{tot} W	R_{thJC} K/W \leq per arm	outline / page	
 GAL Chopper	Standard 2. Generation							
	BSM25GAL120DN2	1200	25	2,5	200	0,6	IS4/63	
	BSM50GAL120DN2	1200	50	2,5	400	0,3	IS4/63	
	BSM75GAL120DN2	1200	75	2,5	625	0,2	IS4/63	
	BSM100GAL120DN2	1200	100	2,5	800	0,16	IS5/63	
	BSM150GAL120DN2	1200	150	2,5	1250	0,1	IS5/63	
	BSM200GAL120DN2	1200	200	2,5	1400	0,09	IS5/63	
	Low Loss 2. Generation							
	BSM100GAL120DLCK	1200	100	2,1	830	0,15	IS4/63	
	BSM150GAL120DLC	1200	150	2,1	1200	0,1	IS5/63	
	BSM200GAL120DLC	1200	200	2,1	1300	0,09	IS5/63	
	BSM300GAL120DLC	1200	300	2,1	2500	0,05	IS5/63	
	IGBT3							
	◆ FD200R12KE3	1200	200	1,7	1040	0,12	IS5a/63	
	◆ FD300R12KE3	1200	300	1,7	1470	0,085	IS5a/63	
 GAR Chopper	Standard 2. Generation							
	BSM75GAR120DN2	1200	75	2,5	625	0,2	IS4/63	
	BSM100GAR120DN2	1200	100	2,5	800	0,16	IS5/63	
	BSM150GAR120DN2	1200	150	2,5	1250	0,1	IS5/63	
	BSM200GAR120DN2	1200	200	2,5	1400	0,09	IS5/63	
	Low Loss 2. Generation							
	BSM300GAR120DLC	1200	300	2,1	2500	0,05	IS5/63	
	IGBT3							
	◆ DF200R12KE3	1200	200	1,7	1040	0,12	IS5a/63	
	◆ DF300R12KE3	1200	300	1,7	1470	0,085	IS5a/63	
 Single Switches	Standard 2. Generation							
	BSM200GA120DN2	1200	200	2,5	1550	0,08	IS6a/63	
	BSM200GA120DN2S	1200	200	2,5	1550	0,08	IS10a/64	
	BSM300GA120DN2	1200	300	2,5	2500	0,05	IS6a/63	
	BSM300GA120DN2S	1200	300	2,5	2500	0,05	IS10a/64	
	BSM300GA120DN2E3166	1200	300	2,5	2500	0,05	IS6a/63	
	BSM400GA120DN2	1200	400	2,5	2700	0,045	IS6a/63	
BSM400GA120DN2S	1200	400	2,5	2700	0,045	IS10a/64		



◆ New type

■ Not for new design

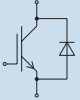
IGBT Standard Modules

1200 V – Type							
Type	V _{CES} V	I _C A	V _{CESat} V T _{vj} =25°C typ.	P _{tot} W	R _{thJC} K/W ≤ per arm	outline / page	
 Single Switches	Low Loss 2. Generation						
	BSM200GA120DLC	1200	200	2,1	1470	0,09	IS6a/63
	BSM200GA120DLCS	1200	200	2,1	1470	0,09	IS10a/64
	BSM300GA120DLC	1200	300	2,1	2270	0,055	IS6a/63
	BSM300GA120DLCS	1200	300	2,1	2270	0,055	IS10a/64
	BSM400GA120DLC	1200	400	2,1	2500	0,05	IS6a/63
	BSM400GA120DLCS	1200	400	2,1	2500	0,05	IS10a/64
	IGBT3						
	◆ FZ300R12KE3G	1200	300	1,7	1470	0,085	IS6a/63
	◆ FZ300R12KE3GS	1200	300	1,7	1470	0,085	IS10a/64
	◆ FZ400R12KE3	1200	400	1,7	2250	0,050	IS6a/63
	◆ FZ400R12KE3S	1200	400	1,7	2250	0,055	IS10a/64
	◆ FZ600R12KE3	1200	600	1,7	2500	0,05	IS6a/63
	◆ FZ600R12KE3S	1200	600	1,7	2500	0,05	IS10a/64
	Short Tail						
	FZ400R12KS4	1200	400	3,2	2500	0,05	IS6a/63
	◆ FZ600R12KS4	1200	600	on request	on request	on request	IS6a/63

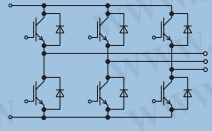
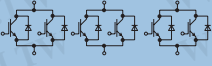
Single Diodes							
Type	V _{CES} V	I _C A	V _F V	P _D W	R _{thJC} K/W ≤	outline / page	
 Single Diodes	BYM 300 A 120 DN 2						
	BYM 300 A 170 DN2	1700	250	2,3	830	0,150	IS11a/64
	BYM 600 A 170 DN 2	1700	400	2,0	1400	0,090	IS11a/64

1700 V – Type							
Type	V _{CES} V	I _C A	V _{CESat} V T _{vj} =25°C typ.	P _{tot} W	R _{thJC} K/W ≤ per arm	outline / page	
 3-Phase- Full-Bridges	Low Loss						
	■ BSM50GD170DL	1700	50	2,7	480	0,27	IS8/64
	■ BSM75GD170DL	1700	75	2,7	625	0,20	IS8/64
 Tripack	Low Loss						
	■ BSM100GT170DL	1700	100	2,7	960	0,13	IS9/64
	■ BSM150GT170DL	1700	150	2,7	1250	0,10	IS9/64
 Half-Bridges	Standard						
	BSM50GB170DN2	1700	50	3,4	500	0,25	IS4/63
	BSM75GB170DN2	1700	75	3,4	625	0,20	IS4/63
	BSM100GB170DN2	1700	100	3,4	1000	0,13	IS5a/63
	BSM150GB170DN2	1700	150	3,4	1250	0,10	IS5a/63
	Low Loss						
	BSM100GB170DLC	1700	100	2,7	960	0,13	IS5a/63
	BSM150GB170DLC	1700	150	2,7	1250	0,10	IS5a/63
	BSM200GB170DLC	1700	200	2,7	1660	0,075	IS5a/63
	 Single Switches	Standard					
BSM200GA170DN2		1700	200	3,4	1750	0,070	IS6a/63
BSM200GA170DN2S		1700	200	3,4	1750	0,070	IS10a/64
BSM300GA170DN2		1700	300	3,4	2500	0,050	IS6a/63
BSM300GA170DN2S		1700	300	3,4	2500	0,050	IS10a/64
Low Loss							
BSM200GA170DLC		1700	200	2,7	1920	0,065	IS6a/63
BSM300GA170DLC		1700	300	2,7	2500	0,050	IS6a/63
BSM400GA170DLC	1700	400	2,7	3120	0,040	IS6a/63	

- ◆ New type
- Not for new design

Power Integrated Modules PIM

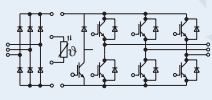
600 V _{CES}														
Type	IGBT Inverter					Rectifier Diodes					Brake Chopper			Outline / page
	V _{CES} V	I _C A	R _{thJC} K/W	V _{CESat} V T _{vj} = 25°C	V _{RRM} V	I _d A T _C = 80°C	R _{thJC} K/W	V _{to} V T _{vj} = 150°C	r _T mΩ T _{vj} = 150°C	V _{CES} V	I _{C,IGBT} A T _C = 80°C	R _{thJC} K/W		
	BSM10GP60	600	10	1,5	1,95	1600	10	1,80	0,8	10,5	600	10	1,5	IS12/65
	BSM15GP60	600	15	1,3	1,95	1600	15	1,20	0,8	10,5	600	10	1,5	IS12/65
	BSM20GP60	600	20	1,0	1,95	1600	20	1,20	0,8	10,5	600	10	1,5	IS12/65
	BSM30GP60	600	30	0,7	1,95	1600	30	1,20	0,8	10,5	600	15	1,3	IS12/65
	BSM50GP60	600	50	0,5	1,95	1600	50	1,00	0,8	10,5	600	25	1,0	IS12/65
	BSM50GP60G	600	50	0,5	1,95	1600	50	1,00	0,8	10,5	600	25	1,0	IS13/65
	BSM75GP60	600	75	0,4	1,95	1600	75	0,65	0,8	6,5	600	37,5	0,7	IS13/65
	BSM100GP60	600	100	0,3	1,95	1600	100	0,50	0,8	4,8	600	50	0,5	IS13/65

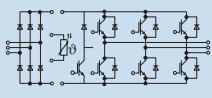
1200 V _{CES}															
Type	IGBT Inverter					Rectifier Diodes					Brake Chopper			Outline / page	
	V _{CES} V	I _C A	R _{thJC} K/W	V _{cesat} V T _{vj} = 25°C	V _{RRM} V	I _d A T _C = 80°C	R _{thJC} K/W	V _{to} V T _{vj} = 150°C	r _T mΩ	V _{CES} V	I _{C,IGBT} A T _C = 80°C	R _{thJC} K/W			
	BSM10GP120	1200	10	1,20	2,40	1600	10	1,80	0,8	10,5	1200	10,0	1,2	IS12/65	
	BSM15GP120	1200	15	0,70	2,20	1600	15	1,20	0,8	10,5	1200	10,0	1,2	IS12/65	
	BSM25GP120	1200	25	0,55	2,10	1600	25	1,20	0,8	10,5	1200	12,5	1,2	IS12/65	
	BSM35GP120	1200	35	0,55	2,40	1600	35	1,00	0,8	10,5	1200	17,5	0,7	IS12/65	
	BSM35GP120G	1200	35	0,55	2,40	1600	35	1,00	0,8	10,5	1200	17,5	0,7	IS13/65	
	BSM50GP120	1200	50	0,35	2,20	1600	50	0,65	0,8	6,5	1200	25,0	0,55	IS13/65	
	Short Tail														
	FP15R12KS4C	1200	15	0,70	3,20	1600	15	1,00	0,8	10,5	1200	10,0	1,2	IS12/65	
	FP25R12KS4C	1200	25	0,55	3,20	1600	25	1,00	0,8	10,5	1200	12,5	1,2	IS12/65	
	FP35R12KS4CG	1200	35	0,55	3,75	1600	35	1,00	0,8	10,5	1200	17,5	0,7	IS13/65	
	FP50R12KS4C	1200	50	0,35	3,20	1600	50	0,65	0,8	6,5	1200	25,0	0,55	IS13/65	
	IGBT3														
	◆ FP15R12KE3G	1200	15	1,20	1,70	1600	15	1,00	0,8	10,5	1200	10,0	1,5	IS12/65	
	◆ FP25R12KE3	1200	25	0,80	1,70	1600	25	1,00	0,8	10,5	1200	15,0	1,2	IS12/65	
	◆ FP40R12KE3	1200	40	0,60	1,80	1600	40	1,00	0,8	10,5	1200	15,0	1,2	IS12/65	
	◆ FP40R12KE3G	1200	40	0,60	1,80	1600	40	1,00	0,8	10,5	1200	40,0	0,6	IS13/65	
	◆ FP50R12KE3	1200	50	0,45	1,70	1600	50	0,65	0,8	6,5	1200	40,0	0,6	IS13/65	
	◆ FP75R12KE3	1200	75	0,35	1,70	1600	75	0,65	0,8	6,5	1200	40,0	0,6	IS13/65	

◆ New type

■ Not for new design

Easy PIM

all Data are preliminary

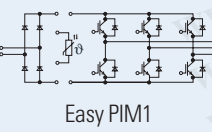
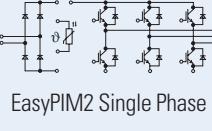
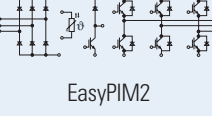
Type	IGBT Inverter					Rectifier Diodes					Brake Chopper			Outline / page
	V_{CES} V	I_C A	R_{thJC} K/W	V_{CESat} V <small>$T_{vj} = 25^\circ\text{C typ.}$</small>	V_{RRM} V	I_d A	R_{thJC} K/W	V_{to} V <small>$T_{vj} = 150^\circ\text{C}$</small>	r_T m Ω	V_{CES} V	$I_{C,IGBT}$ A	R_{thJC} K/W		
 <p>Easy PIM1</p>	Low Loss 2. Generation													
	FB10R06KL4	600	10	2,2	1,95	800	10	2,4	0,67	21				IS15/67
	FB10R06KL4G	600	10	2,2	1,95	800	10	2,4	0,67	21				IS17/67
	FP10R06KL4	600	10	2,2	1,95	800	10	2,4	0,67	21	600	10	2,2	IS16/67
	FB15R06KL4	600	15	2,0	1,95	800	15	1,0	0,61	11				IS17/67
	FP15R06KL4	600	15	2,0	1,95	800	15	2,4	0,71	18	600	15	2,0	IS16/67
 <p>EasyPIM2 Single Phase</p>	FB20R06KL4	600	20	1,6	1,95	800	20	1,0	0,63	10				IS17/67
	FP20R06KL4	600	20	1,6	1,95	800	20	2,0	0,71	12	600	20	1,6	IS16/67
	IGBT3													
 <p>EasyPIM2</p>	FP10R12KE3	1200	10	2,2	1,9	1600	10	1,9	0,78	17	1200	10	2,2	IS16/67
	FP15R12KE3	1200	15	1,4	1,7	1600	15	1,9	0,8	15	1200	15	1,4	IS16/67

Easy PACK

all Data are preliminary

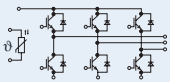
Type	IGBT Inverter		
	V_{CES} V	I_C A	
 <p>EasyPACK</p>	Low Loss 2. Generation		
	FS15R06KL4	600	15
	FS20R06KL4	600	20
	FS30R06KL4	600	30
	FS50R06KL4	600	50
	IGBT3		
	FS10R12KE3	1200	10
	FS15R12KE3	1200	15
	FS25R12KE3	1200	25
FS35R12KE3	1200	35	

EconoPACK +

all Data are preliminary

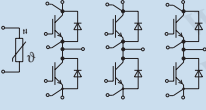
1200 V _{CES}						
Type	V _{CES} V	I _C A	V _{CEsat} V T _{vj} =25 °C typ.	E _{on} /E _{off} mWs T _{vj} =125 °C typ.	R _{thJC} K/W	outline / page
 IGBT3 ◆ FS150R12KE3G ◆ FS225R12KE3 ◆ FS300R12KE3 ◆ FS450R12KE3	1200	150	1,7	11/24	0,17	IS14/66
	1200	225	1,7	15/36	0,11	IS14/66
	1200	300	1,7	22/43	0,08	IS14/66
	1200	450	1,7	33/65	0,06	IS14/66

◆ New type

■ Not for new design

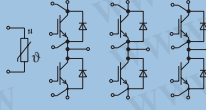
1700 V _{CES}						
Type	V _{CES} V	I _C A	V _{CEsat} V T _{vj} =25 °C typ.	E _{on} /E _{off} mWs T _{vj} =125 °C typ.	R _{thJC} K/W	outline / page
 IGBT3 ◆ FS150R17KE3G ◆ FS225R17KE3 ◆ FS300R17KE3 ◆ FS450R12KE3	1700	150	26	5/40	0,12	IS12/65
	1700	225	28	5/57	0,09	IS12/65
	1700	300	212	5/83	0,08	IS12/65
	1700	450	216	0/120	0,055	IS12/65

IGBT Drivers

Type	No. of Channels	Gate Voltage V	IGBT max. V_{CE} V	V_{ISO} V	I_{peak} A	Power Out/Channel W	outline/page	remarks
2SD 106 AI	2	+/- 15	1200	2500	6	1	SD1/87	adaption to various modules
2SD 106 AI-17	2	+/- 15	1700	4000	6	1	SD1/87	adaption to various modules
6SD 106 EI	6	+/- 15	1200	2500	6	1	SD3/87	adaption to various modules
6SD 106 EI-17	6	+/- 15	1700	4000	6	1	SD3/87	adaption to various modules
2SD 315 AI	2	+/- 15	1700	4000	15	3	SD2/87	adaption to various modules
2SD 315 AI-25	2	+/- 15	2500	5000	15	3	SD2/87	adaption to various modules
2SD 315 AI-33	2	+/- 15	3300	6000	15	3	SD2/87	adaption to various modules
1SD 418 FI-FZ2400R17KF6-B2	1	+/- 15	1700	4000	18	4	na	dedicated to FZ2400R17KF6-B2
1SD 418 FI-FZ800R33KF2	1	+/- 15	3300	6000	18	4	na	dedicated to FZ800R33KF2
1SD 418 FI-FZ1200R33KF2	1	+/- 15	3300	6000	18	4	na	dedicated to FZ1200R33KF2

"IGBT Module & Driver Selection" Excel sheet for appropriate dimensioning of SCALE drivers on request.

Features:

Short circuit and overcurrent protection of the IGBT

Direct half-bridge mode with locking & dead-time generation (selectable)

Switching frequency DC to > 100 kHz (driver chip set)

Input Signals +5V ... +15V (programmable)

Electrical separation of addressing and error acknowledgment (via transformers)

High dv/dt immunity

Under-voltage monitoring

Complete with DC/DC converter

Operating temperature - 40°C ... + 85°C

IGBT Driver Boards

Type	Channels	Control Interface	V_{DC} average/Peak	V_{ISO} V	I_{GM} A	P_{OUT} W	size mm-mm	mounting by	for modules	outline / page
IGD-1-EP 615	1	E	800/1000	4000	±15	6	74-116	screw on	140-190 mm up to 1200 V	4/88
IGD-1-EP 615-17	1	E	1000/1400	4000	±15	6	74-116	screw on	140-190 mm up to 1700 V	4/88
IGD-1-WP 515	1	O	1000/1400	7500	±15	5	74-116	screw on	140-130 mm up to 1700 V	6/89
IGD-1-DT2 515	2	O	1000/1400	7500	±15	2.5	130-140	screw on	dual 140-130 mm up to 1700 V	7/89
IGD-1-DT 515	2	O	2000/2500	7500	±15	2.5	130-140	screw on	dual 140-130 mm > 1700 V	8/89
IGD-1-EP 515	1	O	2000/2500	7500	±15	5	74-116	screw on	140-190 mm up to 3300 V, 140-130 mm >1700 V	5/89

Features:

Short circuit or overcurrent protection of the IGBT

Only one supply voltage (0V, +15V)

Undervoltage lockout

Duty cycle from 0% to 100%

Positive and negative gate voltage (±15 V)

Isolated failure feedback

High dv/dt immunity of min. 50000V/ms

IsoPACK Bridge Rectifier

		Type	V_{DRM}, V_{RRM} V $V_{DSM} = V_{DRM}$ $V_{RSM} = V_{RRM} + 100V$	I_{FRMSM} (I_{TRMSM}) A	I_{FSM} (I_{TSM}) A 10 ms, $T_{vj\ max}$	I_d/T_c A/°C	$V_{(TO)}$ V $T_{vj} = T_{vj\ max}$	r_T mΩ $T_{vj} = T_{vj\ max}$	R_{thJC} °C/W per arm 120° el Square wave	$T_{vj\ max}$ °C	outline / page
3 phase bridge rectifier, uncontrolled		DD B6U 85 N ¹⁾	1200, 1600	60	550	85/100	0,75	5,5	1,45	150	IP1/68
		DD B6U 145 N ¹⁾	1200, 1600	100	1000	145/100	0,75	3,1	0,89	150	IP1/68
		DD B6U 205 N ¹⁾	1200, 1600	120	1375	205/100	0,75	2,2	0,59	150	IP1/68
		DD B6U 215 N ²⁾	1200, 1600	125	1950	215/110	0,75	1,6	0,49	150	IP2/68
3 phase bridge rectifier, half controlled		TD B6HK 95 N ²⁾	1200, 1600	75	620	95/85	0,95	5,5	0,82	125	IP2/68
		TD B6HK 135 N ²⁾	1200, 1600	100	900	135/85	0,95	4,3	0,59	125	IP2/68
		TD B6HK 165 N ²⁾	1200, 1600	120	1200	165/85	0,95	3,2	0,49	125	IP2/68
		TD B6HK 205 N ²⁾	1200, 1600	120	1375	205/85	0,95	2,2	0,41	125	IP2/68
3 phase bridge rectifier, fully controlled		TT B6C 95 N ²⁾	1200, 1600	75	620	95/85	0,95	5,5	0,82	125	IP2/68
		TT B6C 135 N ²⁾	1200, 1600	100	900	135/85	0,95	4,3	0,59	125	IP2/68
		TT B6C 165 N ²⁾	1200, 1600	120	1200	165/85	0,95	3,2	0,49	125	IP2/68

IsoPACK AC-Switches

		Type	V_{DRM}, V_{RRM} V $V_{DSM} = V_{DRM}$ $V_{RSM} = V_{RRM} + 100V$	I_{FRMSM} (I_{TRMSM}) A	I_{FSM} (I_{TSM}) A 10 ms, $T_{vj\ max}$	I_{RMS}/T_c A/°C	$V_{(TO)}$ V $T_{vj} = T_{vj\ max}$	r_T mΩ $T_{vj} = T_{vj\ max}$	R_{thJC} °C/W per arm 180° el Sinus	$T_{vj\ max}$ °C	outline / page
3 phase AC-Switches, fully controlled		TT W3C 85 N ²⁾	1200, 1600	75	620	85/85	0,95	5,5	0,70	125	IP2/68
		TT W3C 115 N ²⁾	1200, 1600	100	900	115/85	0,95	4,3	0,50	125	IP2/68
		TT W3C 145 N ²⁾	1200, 1600	120	1200	145/85	0,95	3,2	0,42	125	IP2/68
3 phase AC-Switches, half controlled		TD W3H 115 N ²⁾	1200, 1600	100	900	115/85	0,95	4,3	0,50	125	IP2/68

IsoPACK modules are UL recognized

Sets of screws will be included at customer's request at no cost. Requests must be made at time of order.

¹⁾ IsoPACK 42: 30 pcs. M 5 x 11 for 5 modules – see page 93

²⁾ IsoPACK 54: 30 pcs. M 6 x 15 for 5 modules – see page 93

EconoBRIDGE Rectifier

		Type	V_{DRM}, V_{RRM} V $V_{DSM} = V_{DRM}$ $V_{RSM} =$ $V_{RRM} + 100V$	I_{FRMSM} (I_{TRMSM}) A	I_{FSM} (I_{TSM}) A 10 ms, $T_{vj\ max}$	I_d/T_c $A/°C$	$V_{(T0)}$ V $T_{vj} = T_{vj\ max}$	r_T $m\Omega$ $T_{vj} = T_{vj\ max}$	R_{thJC} $°C/W$ per arm 120° el. Square wave	$T_{vj\ max}$ $°C$	Brake IGBT		outline/ page
											V_{CES} V	I_C A	
3 phase bridge rectifier, uncontrolled		DD B6U 84N..R	1200, 1600	60	550	85/100	0,75	5,5	1,45	150			EC1/69
		DD B6U 100 N..R	1200, 1600	60	550	100/100	0,75	5,5	1,15	150			EC1/69
		DD B6U 144 N..R	1200, 1600	100	1000	145/100	0,75	3,1	0,89	150			EC1/69
3 phase bridge rectifier, uncontrolled with brake chopper		DD B6U 84N..RR	1200, 1600	60	550	85/100	0,75	5,5	1,45	150	1200	50	EC2/69
		DD B6U 100N..RR	1200, 1600	60	550	100/100	0,75	5,5	1,15	150	1200	50	EC2/69
3 phase bridge rectifier, uncontrolled with brake chopper and NTC		DD B6U 104 N 16 RR	1600	60	550	105/100	0,75	5,5	1,00	150	1200	50	EC4/69
		DD B6U 134 N 16 RR	1600	80	550	134/100	0,75	6,3	0,70	150	1200	70	EC4/69
3 phase bridge rectifier, halfcontrolled with brake chopper and NTC		TD B6HK 74 N 16 RR	1600	45	400	75/85	0,75	9,1	1,10	125	1200	50	EC3/69
		TD B6HK 104 N 16 RR	1600	60	500	104/85	0,80	7,0	0,75	125	1200	50	EC3/69
		TD B6HK 124 N 16 RR	1600	60	550	125/85	0,75	6,3	0,80	125	1200	70	EC3/69

EconoBRIDGE Rectifiers are UL recognized

Overview PowerBLOCK Thyristor Modules

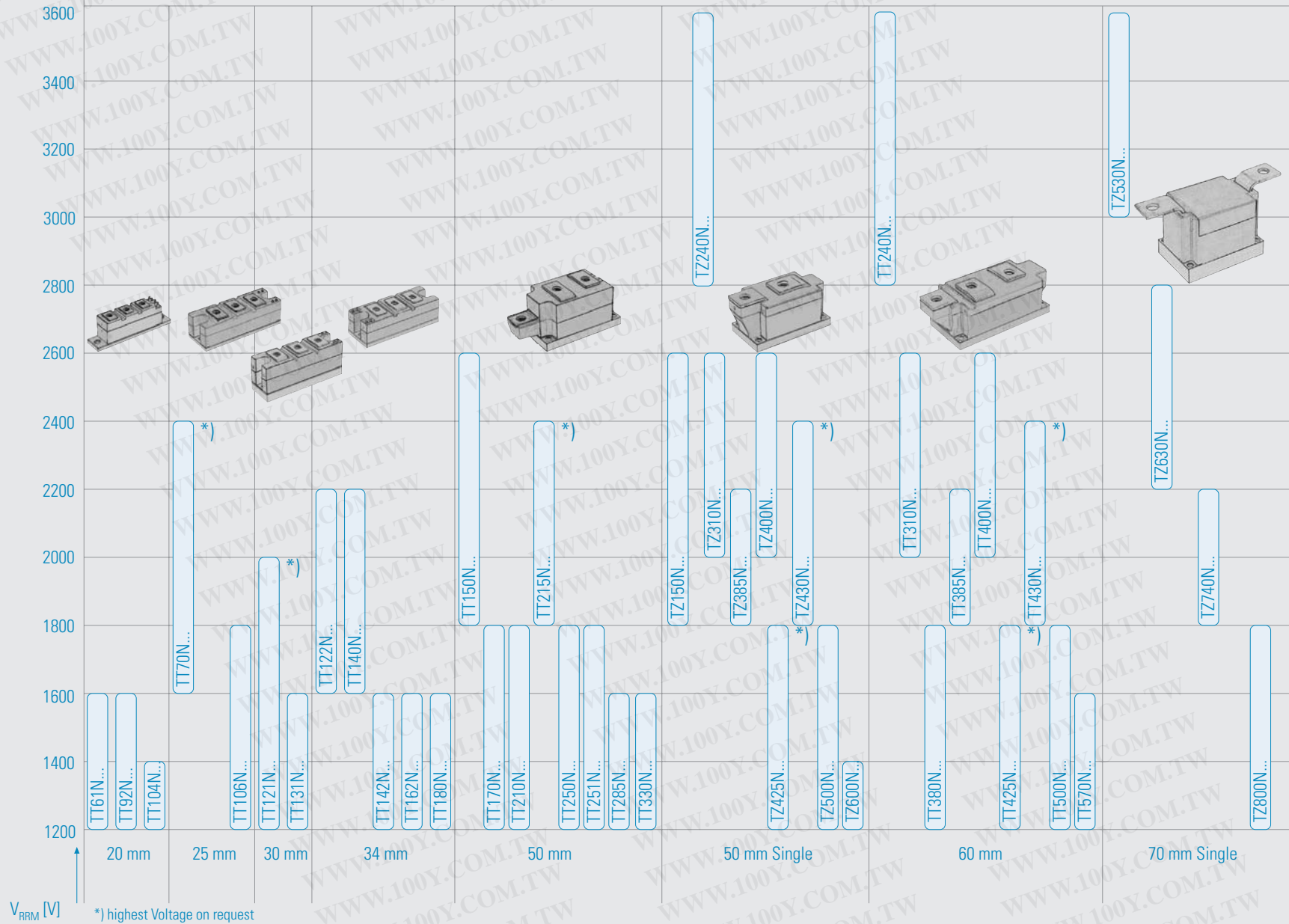

PowerBLOCK Thyristor Modules

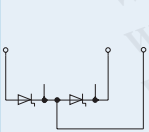
	Type	V_{DRM}	I_{TRMSM}	I_{TSM}	$\int i^2 dt$	I_{TAVM}/T_c	$V_{(T0)}$	r_T	$(di/dt)_{cr}$	t_q	$(dv/dt)_{cr}$	R_{thJC}	R_{thCK}	$T_{vj\ max}$	outline / page
		V_{RRM} V $V_{DSM} = V_{DRM}$ $V_{RSM} = V_{RRM} + 100$ V	A	A	$A^2s \cdot 10^3$ 10 ms, $T_{vj\ max}$	$A/^\circ C$ 180° el sin	V $T_{vj} = T_{vj\ max}$	$m\Omega$ $T_{vj} = T_{vj\ max}$	A/ μs DIN IEC 747 - 6	μs typ.	V/ μs DIN IEC 747 - 6	$^\circ C/W$ 180° el sin	$^\circ C/W$	$^\circ C$	
Baseplate = 20 mm	TT 61 N	1200 ... 1600	120	1400	9,8	60/85	0,80	3,40	150	120	F = 1000	0,52	0,16	125	TP20/70
	TT 92 N	1000 ... 1600	160	1800	16,2	92/85	0,85	2,15	150	150	F = 1000	0,37	0,10	130	TP20/70
	TT 104 N	1000 ... 1400	160	1800	16,2	104/85	0,85	2,15	150	150	F = 1000	0,37	0,10	140	TP20/70
Baseplate = 25 mm	TT 70 N	1600 ... 2400*	150	1450	10,5	70/85	1,00	3,80	100	300	F = 1000	0,35	0,08	125	TP25/70
	TT 106 N	1000 ... 1800	180	2000	20,0	106/85	0,90	2,60	150	150	F = 1000	0,33	0,08	140	TP25/70
Baseplate = 30 mm	TT 121 N	1200 ... 2000*	200	2350	27,6	121/85	0,85	2,00	150	180	F = 1000	0,23	0,06	125	TP30/70
	TT 131 N	1200 ... 1600	220	3200	51,2	131/85	0,85	1,50	150	180	F = 1000	0,23	0,06	125	TP30/70
Baseplate = 34 mm	TT 122 N	1600 ... 2200	220	2950	43,5	122/85	1,00	2,15	100	300	F = 1000	0,2	0,06	125	TP34/70
	TT 140 N	1600 ... 2200	250	3200	51,2	140/85	0,90	1,75	150	300	F = 1000	0,19	0,06	125	TP34/70
	TT 142 N	1200 ... 1600	230	4100	84	142/85	0,90	1,10	150	200	F = 1000	0,22	0,06	125	TP34/70
	TT 162 N	1200 ... 1600	260	4400	97	162/85	0,85	0,95	150	200	F = 1000	0,20	0,06	125	TP34/70
	TT 180 N	1200 ... 1600	285	4100	84	180/85	0,85	0,90	150	200	F = 1000	0,20	0,06	130	TP34/70
Baseplate = 50 mm	TT 150 N	1800 ... 2600	350	4000	80	150/85	1,20	2,30	60	300	F = 1000	0,13	0,04	125	TP50/70
	TT 170 N	1000 ... 1800	350	4600	106	170/85	0,95	1,00	150	250	F = 1000	0,17	0,04	125	TP50/70
	TT 210 N	1000 ... 1800	410	5800	168	210/85	1,00	0,85	150	200	F = 1000	0,13	0,04	125	TP50/70
	TT 215 N	1800 ... 2400*	410	6300	198	215/85	0,95	0,92	100	300	F = 1000	0,13	0,04	125	TP50/70
	TT 250 N	1000 ... 1800	410	7000	245	250/85	0,80	0,70	150	250	F = 1000	0,13	0,04	125	TP50/70
	TT 251 N	1000 ... 1800	410	8000	320	250/85	0,80	0,70	250	250	F = 1000	0,13	0,04	125	TP50/70
	TT 285 N	1200 ... 1600	450	8000	320	285/92	0,80	0,70	250	250	F = 1000	0,13	0,04	135	TP50/70
	TT 330 N	1200 ... 1600	520	8000	320	330/85	0,80	0,60	250	250	F = 1000	0,117	0,04	135	TP50/70
Baseplate = 60 mm	TT 240 N	2800 ... 3600	700	5500	151	240/85	1,17	1,70	100	350	F = 1000	0,078	0,02	125	TP60/70
	TT 310 N	2000 ... 2600	700	9000	405	310/85	1,00	0,86	120	300	F = 1000	0,078	0,02	125	TP60/70
	TT 380 N	1000 ... 1800*	800	11000	605	380/85	1,00	0,38	120	250	F = 1000	0,078	0,02	125	TP60/70
	TT 385 N	1800 ... 2200						data on request							TP60/70
	TT 400 N	2000 ... 2600	800	11000	605	400/85	1,00	0,50	150	300	F = 1000	0,065	0,02	125	TP60/70
	TT 425 N	1000 ... 1800*	800	12500	781	425/85	0,90	0,30	120	250	F = 1000	0,078	0,02	125	TP60/70
	TT 430 N	1800 ... 2200*	800	12000	720	430/85	0,95	0,45	150	300	F = 1000	0,065	0,02	125	TP60/70
	TT 500 N	1000 ... 1800	900	14500	1051	500/85	0,90	0,27	200	250	F = 1000	0,065	0,02	125	TP60/70
	TT 570 N	1200 ... 1600	900	14000	980	570/87	0,90	0,27	200	250	F = 1000	0,065	0,02	135	TP60/70

PowerBLOCK modules are UL recognized

Common anode or cathode on request

* Highest voltage on request

PowerBLOCK Single Thyristor Modules

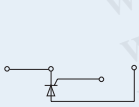
	Type	V_{DRM} V_{RRM} V $V_{DSM} = V_{DRM}$ $V_{RSM} =$ $V_{RRM} + 100$ V	I_{TRMSM} A	I_{TSM} A 10 ms, $T_{vj\ max}$	$\int i^2 dt$ $A^2 \cdot 10^{-3}$ 10 ms, $T_{vj\ max}$	I_{TAVM}/T_c $A/^\circ C$ 180° el sin	$V_{(TO)}$ V $T_{vj} = T_{vj\ max}$	r_T $m\Omega$ $T_{vj} = T_{vj\ max}$	$(di/dt)_{cr}$ A/ μs DIN IEC 747 - 6	t_q μs typ.	$(dv/dt)_{cr}$ V/ μs DIN IEC 747 - 6	R_{thJC} $^\circ C/W$ 180° el sin	R_{thCK} $^\circ C/W$	$T_{vj\ max}$ $^\circ C$	outline / page
Baseplate = 50 mm	TZ 150 N	1800 ... 2600	350	4000	80	150/85	1,20	2,30	60	300	F = 1000	0,13	0,04	125	TP50.1/71
	TZ 240 N	2800 ... 3600	700	5500	151	240/85	1,17	1,70	100	350	F = 1000	0,078	0,02	125	TP50.1/71
	TZ 310 N	2000 ... 2600	700	8000	320	310/85	1,00	0,86	120	300	F = 1000	0,078	0,02	125	TP50.1/71
	TZ 385 N	1800 ... 2200							data on request						TP50.1/71
	TZ 400 N	2000 ... 2600	1050	11000	605	400/85	1,00	0,50	150	300	F = 1000	0,065	0,02	125	TP50.1/71
	TZ 425 N	1000 ... 1800*	800	12500	781	425/85	0,90	0,30	120	250	F = 1000	0,078	0,02	125	TP50.1/71
	TZ 430 N	1800 ... 2200*	1050	12000	720	430/85	0,95	0,45	150	300	F = 1000	0,065	0,02	125	TP50.1/71
	TZ 500 N	1000 ... 1800	1050	14500	1051	500/85	0,90	0,27	200	250	F = 1000	0,065	0,02	125	TP50.1/71
TZ 600 N	1000 ... 1400	1050	14000	980	600/85	0,90	0,27	200	250	F = 1000	0,065	0,02	135	TP50.1/71	
Baseplate = 70 mm	TZ 530 N	3000 ... 3600	1500	20000	2000	530/85	1,05	0,49	80	400	F = 1000	0,045	0,01	125	TP70/71
	TZ 630 N	2200 ... 2800	1500	23000	2650	630/85	0,95	0,37	150	400	F = 1000	0,042	0,01	125	TP70/71
	TZ 740 N	1800 ... 2200	1500	26500	3500	740/85	0,90	0,21	200	350	F = 1000	0,042	0,01	125	TP70/71
	TZ 800 N	1200 ... 1800	1500	30000	4500	800/85	0,85	0,17	200	240	F = 1000	0,042	0,01	125	TP70/71

PowerBLOCK modules are UL recognized

* Highest voltage on request

Overview PowerBLOCK Thyristor/Diode Modules

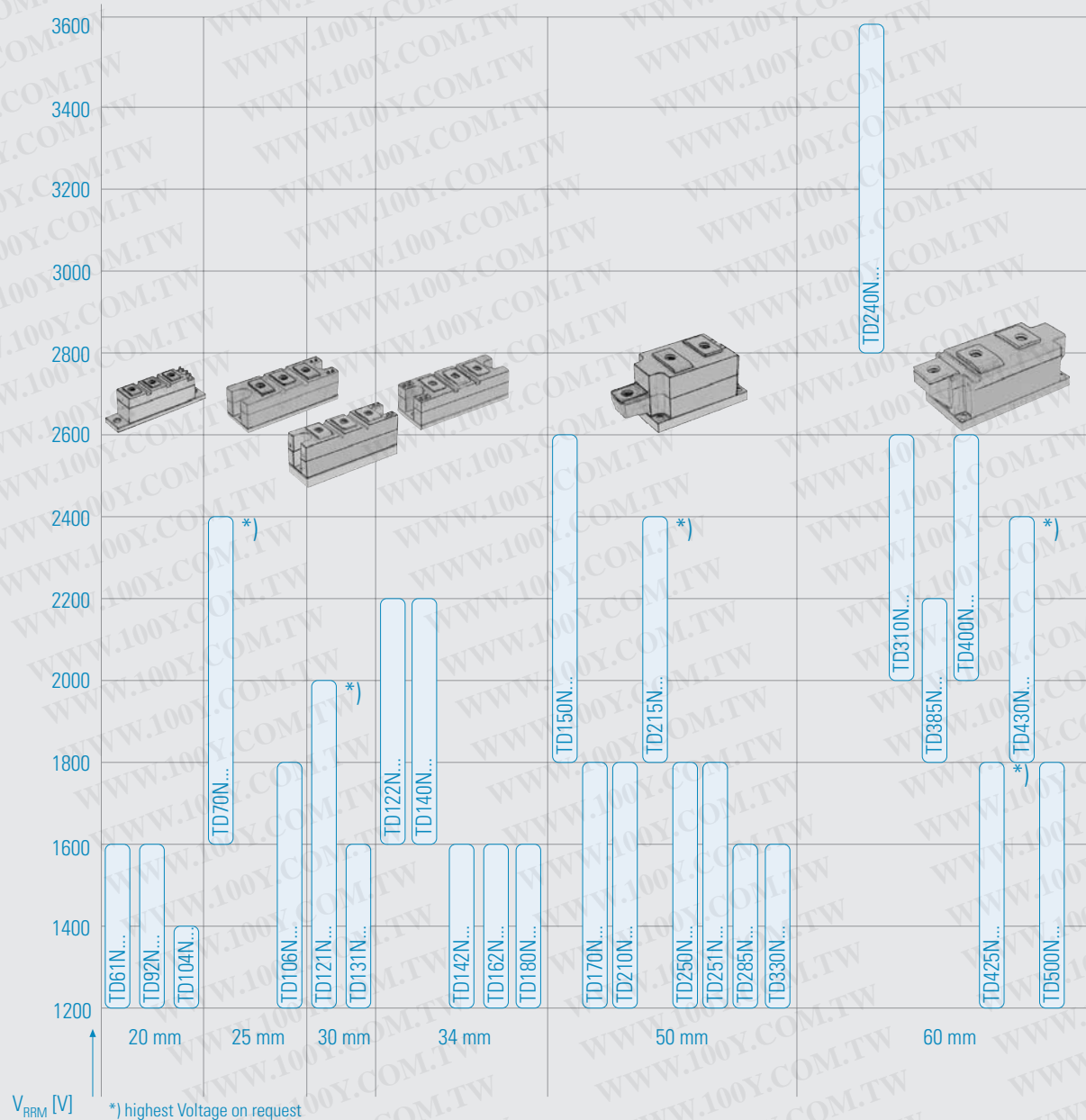

PowerBLOCK Thyristor/Diode Modules

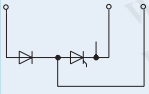
	Type	V_{DRM}	I_{TRMSM}	I_{TSM}	$\int i^2 dt$	I_{TAVM}/T_c	$V_{(TO)}$	r_T	$(di/dt)_{cr}$	t_q	$(dv/dt)_{cr}$	R_{thJC}	R_{thCK}	$T_{vj\ max}$	outline / page
		V_{RRM} $V_{DSM} = V_{DRM}$ $V_{RSM} = V_{RRM} + 100\ V$													
Baseplate = 20 mm	TD61N	1200 ... 1600	120	1400	9,8	60/85	0,80	3,40	150	120	F = 1000	0,52	0,16	125	TP20/70
	TD92N	1000 ... 1600	160	1800	16,2	92/85	0,85	2,15	150	150	F = 1000	0,37	0,10	130	TP20/70
	TD104N	1000 ... 1400	160	1800	16,2	104/85	0,85	2,15	150	150	F = 1000	0,37	0,10	140	TP20/70
Baseplate = 25 mm	TD70N	1600 ... 2400*	150	1450	10,5	70/85	1,00	3,80	100	300	F = 1000	0,35	0,08	125	TP25/70
	TD106N	1000 ... 1800	180	2000	20,0	106/85	0,90	2,60	150	150	F = 1000	0,33	0,08	140	TP25/70
Baseplate = 30 mm	TD121N	1200 ... 2000*	200	2350	27,6	121/85	0,85	2,00	150	180	F = 1000	0,23	0,06	125	TP30/70
	TD131N	1200 ... 1600	220	3200	51,2	131/85	0,85	1,50	150	180	F = 1000	0,23	0,06	125	TP30/70
Baseplate = 34 mm	TD122N	1600 ... 2200	220	2950	43,5	122/85	1,00	2,15	100	300	F = 1000	0,20	0,06	125	TP34/70
	TD140N	1600 ... 2200	250	3200	51,2	140/85	0,90	1,75	150	300	F = 1000	0,19	0,06	125	TP34/70
	TD142N	1200 ... 1600	230	4100	84	142/85	0,90	1,10	150	200	F = 1000	0,22	0,06	125	TP34/70
	TD162N	1200 ... 1600	260	4400	97	162/85	0,85	0,95	150	200	F = 1000	0,20	0,06	125	TP34/70
	TD180N	1200 ... 1600	285	4100	84	180/85	0,85	0,90	150	200	F = 1000	0,20	0,06	130	TP34/70
Baseplate = 50 mm	TD150N	1800 ... 2600	350	4000	80	150/85	1,20	2,30	60	300	F = 1000	0,13	0,04	125	TP50/70
	TD170N	1000 ... 1800	350	4600	106	170/85	0,95	1,00	150	250	F = 1000	0,17	0,04	125	TP50/70
	TD210N	1000 ... 1800	410	5800	168	210/85	1,00	0,85	150	200	F = 1000	0,13	0,04	125	TP50/70
	TD215N	1800 ... 2400*	410	6300	198	215/85	0,95	0,92	100	300	F = 1000	0,13	0,04	125	TP50/70
	TD250N	1000 ... 1800	410	7000	245	250/85	0,80	0,70	150	250	F = 1000	0,13	0,04	125	TP50/70
	TD251N	1000 ... 1800	410	8000	320	250/85	0,80	0,70	250	250	F = 1000	0,13	0,04	125	TP50/70
	TD285N	1200 ... 1600	450	8000	320	285/92	0,80	0,70	250	250	F = 1000	0,13	0,04	135	TP50/70
	TD330N	1200 ... 1600	520	8000	320	330/85	0,80	0,60	250	250	F = 1000	0,117	0,04	135	TP50/70
Baseplate = 60 mm	TD240N	2800 ... 3600	700	5500	151	240/85	1,17	1,70	100	350	F = 1000	0,078	0,02	125	TP60/70
	TD310N	2000 ... 2600	700	9000	405	310/85	1,00	0,86	120	300	F = 1000	0,078	0,02	125	TP60/70
	TD385N	1800 ... 2200					data on request								TP60/70
	TD400N	2000 ... 2600	800	11000	605	400/85	1,00	0,50	150	300	F = 1000	0,065	0,02	125	TP60/70
	TD425N	1000 ... 1800*	800	12500	781	425/85	0,90	0,30	120	250	F = 1000	0,078	0,02	125	TP60/70
	TD430N	1800 ... 2400*	800	12000	720	430/85	0,95	0,45	150	300	F = 1000	0,065	0,02	125	TP60/70
	TD500N	1000 ... 1800	900	14500	1051	500/85	0,90	0,27	200	250	F = 1000	0,065	0,02	125	TP60/70

PowerBLOCK modules are UL recognized

Common anode or cathode on request

* Highest voltage on request

Overview PowerBLOCK Diode/Thyristor Modules

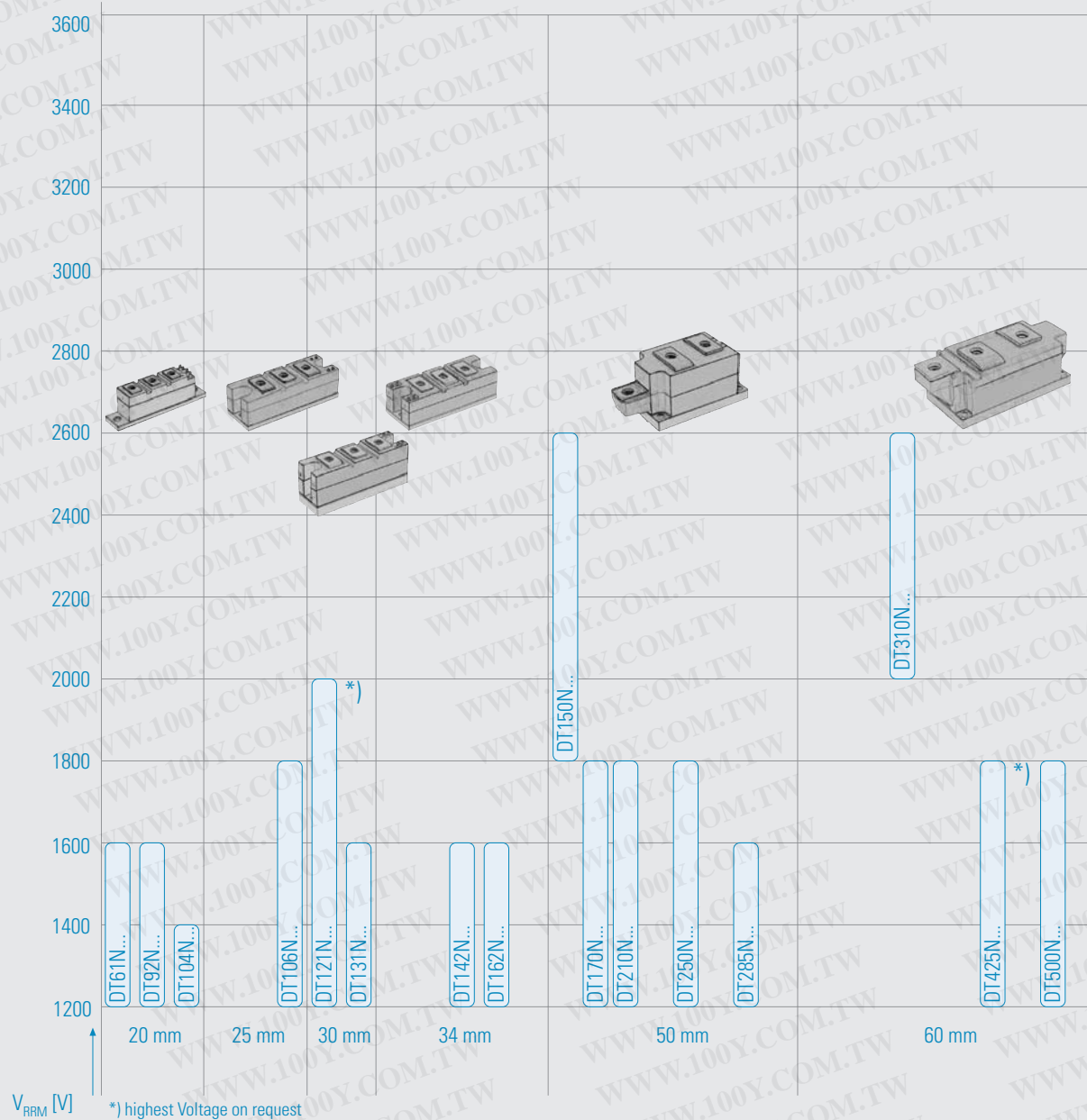

PowerBLOCK Diode/Thyristor Modules

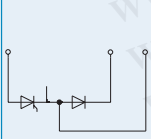

	Type	V_{DRM} V_{RRM} V $V_{DSM} = V_{DRM}$ $V_{RSM} =$ $V_{RRM} + 100$ V	I_{TRMSM} A	I_{TSM} A 10 ms, $T_{vj\ max}$	$\int i^2 dt$ $A^2 \cdot s \cdot 10^3$ 10 ms, $T_{vj\ max}$	I_{TAVM}/T_c $A/^\circ C$ 180° el sin	$V_{(TO)}$ V $T_{vj} = T_{vj\ max}$	r_T $m\Omega$ $T_{vj} = T_{vj\ max}$	$(di/dt)_{cr}$ A/ μs DIN IEC 747 - 6	t_q μs typ.	$(dv/dt)_{cr}$ V/ μs DIN IEC 747 - 6	R_{thJC} $^\circ C/W$ 180° el sin	R_{thCK} $^\circ C/W$	$T_{vj\ max}$ $^\circ C$	outline / page
Baseplate = 20 mm	DT61N	1200 ... 1600	120	1400	9,8	60/85	0,80	3,40	150	120	F = 1000	0,52	0,16	125	TP20/70
	DT92N	1000 ... 1600	160	1800	16,2	92/85	0,85	2,15	150	150	F = 1000	0,37	0,10	130	TP20/70
	DT104N	1000 ... 1400	160	1800	16,2	104/85	0,85	2,15	150	150	F = 1000	0,37	0,10	140	TP20/70
Baseplate = 25 mm	DT106N	1000 ... 1800	180	2000	20,0	106/85	0,90	2,60	150	150	F = 1000	0,33	0,08	140	TP25/70
Baseplate = 30 mm	DT121N	1200 ... 2000*	200	2350	27,6	121/85	0,85	2,00	150	180	F = 1000	0,23	0,06	125	TP30/70
	DT131N	1200 ... 1600	220	3200	51,2	131/85	0,85	1,50	150	180	F = 1000	0,23	0,06	125	TP30/70
Baseplate = 34 mm	DT142N	1200 ... 1600	230	4100	84	142/85	0,90	1,10	150	200	F = 1000	0,22	0,06	125	TP34/70
	DT162N	1200 ... 1600	260	4400	97	162/85	0,85	0,95	150	200	F = 1000	0,20	0,06	125	TP34/70
Baseplate = 50 mm	DT150N	1800 ... 2600	350	4000	80	150/85	1,20	2,30	60	300	F = 1000	0,13	0,04	125	TP50/70
	DT170N	1000 ... 1800	350	4600	106	170/85	0,95	1,00	150	250	F = 1000	0,17	0,04	125	TP50/70
	DT210N	1000 ... 1800	410	5800	168	210/85	1,00	0,85	150	200	F = 1000	0,13	0,04	125	TP50/70
	DT250N	1000 ... 1800	410	7000	245	250/85	0,80	0,70	150	250	F = 1000	0,13	0,04	125	TP50/70
	DT285N	1200 ... 1600	450	8000	320	285/92	0,80	0,70	250	250	F = 1000	0,13	0,04	135	TP50/70
Baseplate = 60 mm	DT310N	2000 ... 2600	700	9000	405	310/85	1,00	0,86	120	300	F = 1000	0,078	0,02	125	TP60/70
	DT425N	1000 ... 1800*	800	12500	781	425/85	0,90	0,30	120	250	F = 1000	0,078	0,02	125	TP60/70
	DT500N	1000 ... 1800	900	14500	1051	500/85	0,90	0,27	200	250	F = 1000	0,065	0,02	125	TP60/70

PowerBLOCK modules are UL recognized

Common anode or cathode on request

* Highest voltage on request

Overview PowerBLOCK Diode Modules

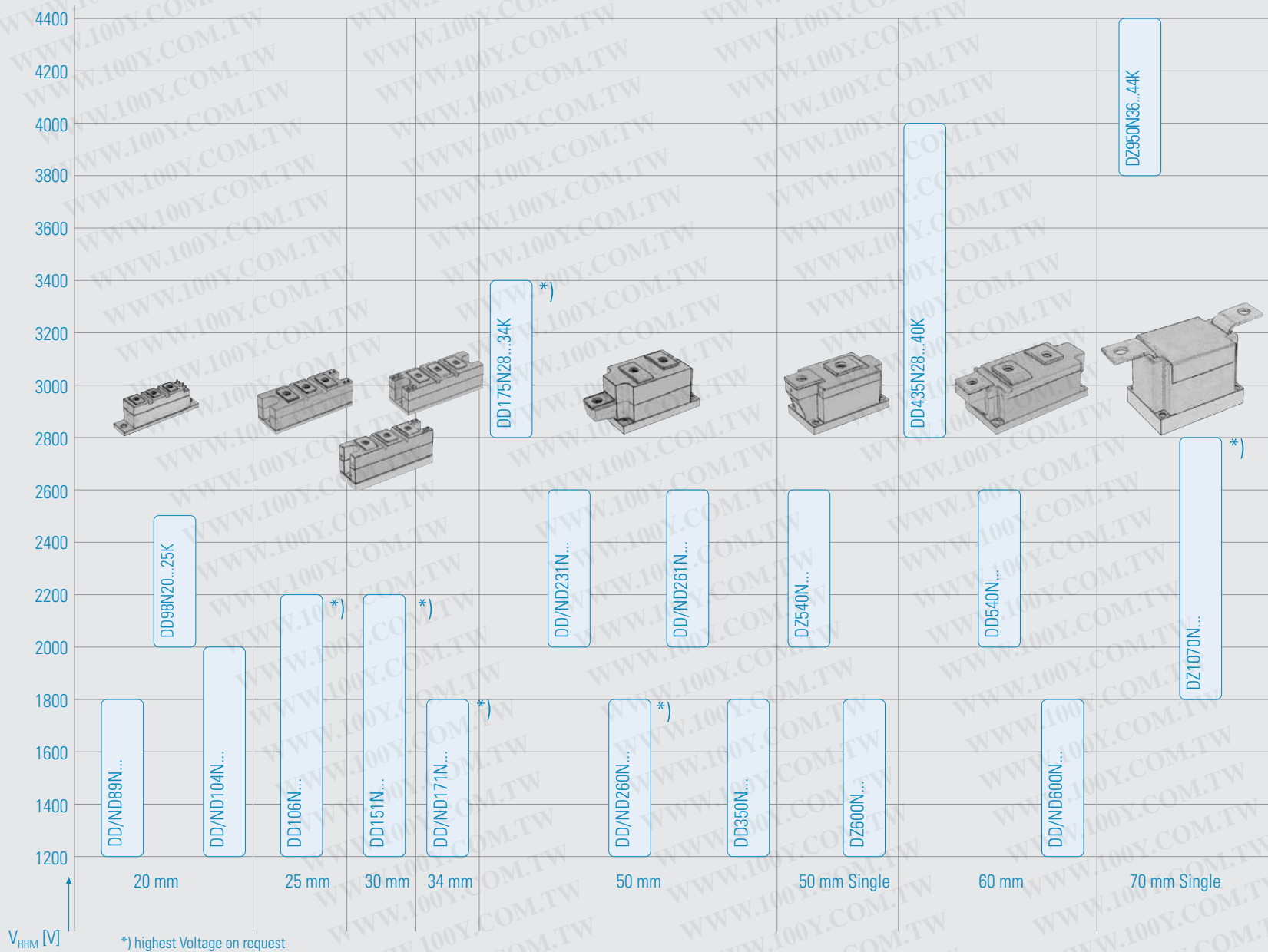

PowerBLOCK Diode Modules

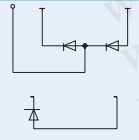
	Type	V_{RRM}	I_{FRMSM}	I_{FSM}	$\int i^2 dt$	I_{FAVM}/T_c	$V_{(T0)}$	r_T	R_{thJC}	R_{thCK}	$T_{vj\ max}$	outline / page
		V										
		$= V_{RRM} + 100V$			10 ms, $T_{vj\ max}$	10 ms, $T_{vj\ max}$		$T_{vj} = T_{vj\ max}$	$T_{vj} = T_{vj\ max}$	180° el sin		
Baseplate = 20 mm	DD 89 N	1000 ... 1800	140	2400	28,8	89/100	0,75	2,3	0,45	0,1	150	DP20/71
	ND 89 N	1000 ... 1800	140	2400	28,8	89/100	0,75	2,3	0,45	0,1	150	DP20/71
	DD 98 N	2000 ... 2500	160	2000	20	98/100	0,82	2	0,39	0,1	150	DP20/71
	DD 104 N	1000 ... 1800	160	2500	31,25	104/100	0,70	2,1	0,39	0,1	150	DP20/71
	ND 104 N	1000 ... 1800	160	2500	31,25	104/100	0,70	2,1	0,39	0,1	150	DP20/71
Baseplate = 25 mm	DD 106 N	1200 ... 2200*	180	2600	33,8	106/100	0,70	2	0,39	0,08	150	DP25/71
Baseplate = 30 mm	DD 151 N	1200 ... 2000*	240	4600	105,8	151/100	0,75	0,9	0,3	0,06	150	DP30/71
Baseplate = 34 mm	DD 171 N	1200 ... 1800*	270	5600	157	170/100	0,75	0,8	0,26	0,06	150	DP34/72
	ND 171 N	1200 ... 1800*	270	5600	157	170/100	0,75	0,8	0,26	0,06	150	DP34/72
Baseplate = 50 mm	DD 175N	2800 ... 3400*	350	4000	80	175/100	0,90	1,8	0,17	0,04	150	DP50/72
	DD 231 N	2000 ... 2600	410	6400	205	231/100	0,80	0,84	0,17	0,04	150	DP50/72
	ND 231 N	2000 ... 2600	410	6400	205	231/100	0,80	0,84	0,17	0,04	150	DP50ND/72
	DD 260 N	1000 ... 1800*	410	8300	344	260/100	0,70	0,68	0,17	0,04	150	DP50/72
	ND 260 N	1000 ... 1800*	410	8300	344	260/100	0,70	0,68	0,17	0,04	150	DP50ND/72
	DD 261 N	2000 ... 2600	410	8300	344	260/100	0,70	0,68	0,17	0,04	150	DP50/72
	ND 261 N	2000 ... 2600	410	8300	344	260/100	0,70	0,68	0,17	0,04	150	DP50ND/72
	DD 285 N	400 ... 800	450	8300	344	285/100	0,75	0,4	0,17	0,04	150	DP50/72
	DD 350 N	1000 ... 1800	550	11000	605	350/100	0,75	0,4	0,13	0,04	150	DP50/72
	DZ 540 N	2000 ... 2600	1150	14000	980	540/100	0,78	0,31	0,078	0,02	150	DP50.1/72
DZ 600 N	1200 ... 1800	1150	19000	1805	600/100	0,75	0,215	0,078	0,02	150	DP50.1/72	
Baseplate = 60 mm	DD 435 N	2800 ... 4000	900	12000	720	435/100	0,84	0,6	0,078	0,02	150	DP60/72
	DD 540 N	2000 ... 2600	900	14000	980	540/100	0,78	0,31	0,078	0,02	150	DP60/72
	DD 600 N	1200 ... 1800	950	19000	1800	600/100	0,75	0,215	0,078	0,02	150	DP60/72
	ND 600 N	1200 ... 1800	950	19000	1800	600/100	0,75	0,215	0,078	0,02	150	DP60/72
Baseplate = 70 mm	DZ 950 N	3600 ... 4400	1500	29000	4205	950/100	0,85	0,28	0,042	0,01	150	DP70/72
	DZ 1070 N	1800 ... 2800*	1700	35000	6125	1070/100	0,80	0,17	0,045	0,01	160	DP70/72

PowerBLOCK modules are UL recognized

Common anode or cathode on request

* Highest voltage on request

PowerBLOCK Thyristor/Diode Modules for current source inverters

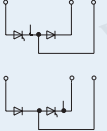
	Type	V_{DRM} V_{RRM} V (Thyr.)	V_{RRM} V (Diode)	I_{TRMSM} A	I_{TSM} A 10 ms, $T_{vj\ max}$	$\int i^2 dt$ $A^2 \cdot s \cdot 10^3$ 10 ms, $T_{vj\ max}$	I_{TAVM}/T_c A/°C 180° el sin	$V_{(TO)}$ V $T_{vj} = T_{vj\ max}$	r_T mΩ $T_{vj} = T_{vj\ max}$	$(di/dt)_{cr}$ V/μs DIN IEC 747 - 6	t_q μs typ.	$(di/dt)_{cr}$ V/μs DIN IEC 747 - 6	R_{thJC} °C/W 180° el sin	R_{thCK} °C/W	$T_{vj\ max}$ °C	outline / page
Baseplate = 20 mm	TD 61 N 14/20	1400	2000	120	1400	9,8	60/85	0,80	3,40	150	120	F = 1000	0,52	0,16	125	TP20/70
	DT 61 N 20/14															
	TD 92 N 14/20	1400	2000	160	1800	16,2	92/85	0,85	2,15	150	150	F = 1000	0,37	0,10	130	TP20/70
	DT 92 N 20/14															
	TD 92 N 16/25	1600	2500	160	1800	16,2	92/85	0,85	2,15	150	150	F = 1000	0,37	0,10	130	TP20/70
DT 92 N 25/16																
Baseplate = 25 mm	TD 106 N 14/20	1400	2000	180	2000	20,0	106/85	0,90	2,60	150	150	F = 1000	0,33	0,08	140	TP25/70
	DT 106 N 20/14															
	TD 106 N 16/25	1600	2500	180	2000	20,0	106/85	0,90	2,60	150	150	F = 1000	0,33	0,08	140	TP25/70
	DT 106 N 25/16															
Baseplate = 30 mm	TD 121 N 14/20	1400	2000	200	2350	27,6	121/85	0,85	2,00	150	180	F = 1000	0,23	0,06	125	TP30/70
	DT 121 N 20/14															
	TD 121 N 16/25	1600	2500	200	2350	27,6	121/85	0,85	2,00	150	180	F = 1000	0,23	0,06	125	TP30/70
	DT 121 N 25/16															
Baseplate = 50 mm	TD 150 N 24/32	2400	3200	350	4000	80,0	150/85	1,20	2,30	60	300	F = 1000	0,13	0,04	125	TP50/70
	DT 150 N 32/24															
	TD 170 N 14/20	1400	2000	350	4600	106,0	170/85	0,95	1,00	150	250	F = 1000	0,17	0,04	125	TP50/70
	DT 170 N 20/14															
	TD 170 N 16/25	1600	2500	350	4600	106,0	170/85	0,95	1,00	150	250	F = 1000	0,17	0,04	125	TP50/70
	DT 170 N 25/16															
	TD 210 N 14/20	1400	2000	410	5800	168,0	210/85	1,00	0,85	150	200	F = 1000	0,13	0,04	125	TP50/70
	DT 210 N 20/14															
	TD 210 N 16/25	1600	2500	410	5800	168,0	210/85	1,00	0,85	150	200	F = 1000	0,13	0,04	125	TP50/70
	DT 210 N 25/16															
	TD 215N22/30	2200	3000	410	6300	198,0	215/85	0,95	0,92	100	300	F = 1000	0,13	0,04	125	TP50/70
	DT 215N30/22															
	TD 250 N 14/20	1400	2000	410	7000	245,0	250/85	0,80	0,70	150	250	F = 1000	0,13	0,04	125	TP50/70
	DT 250 N 20/14						261/82						F = 1000			
TD 250 N 16/25	1600	2500	410	7000	245,0	250/85	0,80	0,70	150	250		0,13	0,04	125	TP50/70	
DT 250 N 25/16																

PowerBLOCK modules are UL recognized

PowerBLOCK Fast Thyristor Modules

	Type	V_{DRM} V_{RRM} V $V_{DSM} = V_{DRM}$ $V_{RSM} =$ $V_{RRM} + 100$ V	I_{TRMSM} A	I_{TSM} A 10 ms, $T_{vj\ max}$	$\int i^2 dt$ $A^2 \cdot s \cdot 10^3$ 10 ms, $T_{vj\ max}$	I_{TAVM}/T_c $A/^\circ C$ 180° el sin	$V_{(TO)}$ V $T_{vj} = T_{vj\ max}$	r_T $m\Omega$ $T_{vj} = T_{vj\ max}$	$(di/dt)_{cr}$ $A/\mu s$ DIN IEC 747 - 6	t_q μs typ.	$(dv/dt)_{cr}$ $V/\mu s$ DIN IEC 747 - 6	R_{thJC} $^\circ C/W$ 180° el sin	R_{thCK} $^\circ C/W$	$T_{vj\ max}$ $^\circ C$	outline / page
Baseplate = 20 mm	TT 46 F	800 ... 1200*	120	1150	6,60	45/85	1,30	3,4	120	F ≤ 25 E ≤ 20	C = 500	0,52	0,16	125	TP20/70
	TD 46 F														
Baseplate = 25 mm	TT 60 F	800 ... 1300*	150	1300	8,45	60/85	1,30	4	200	F ≤ 25 E ≤ 20	C = 500	0,35	0,08	125	TP25/70
Baseplate = 30 mm	TT 71 F	1000 ... 1400*	180	2100	22,00	71/85	1,30	3,1	160	F ≤ 25 E ≤ 20	C = 500	0,3	0,06	125	TP30/70
	TD 71 F														
	DT 71 F														
	TT 81 F ¹⁾	400 ... 800	180	2200	24,20	81/85	1,25	2	160	E ≤ 20 D ≤ 15	C = 500	0,3	0,06	125	TP30/70
	TD 81 F ¹⁾														
	DT 81 F ¹⁾														
	TT 101 F	1000 ... 1400*	200	2400	28,80	101/85	1,20	2,1	160	F ≤ 25 E ≤ 20	C = 500	0,23	0,06	125	TP30/70
	TD 101 F														
	DT 101 F														
TT 111 F ¹⁾	800 ... 1000	200	2600	33,80	111/85	1,20	1,4	200	E ≤ 20 D ≤ 15	C = 500	0,23	0,06	125	TP30/70	
TD 111 F ¹⁾															
DT 111 F ¹⁾															
Baseplate = 50 mm	TT 180 F	1000 ... 1300	350	6000	180,00	180/85	1,30	0,9	200	F ≤ 25 E ≤ 20 S ≤ 18	C = 500	0,13	0,04	125	TP50/70
	TD 180 F														
	DT 180 F														
	TT 200 F	1000 ... 1300*	410	6400	205,00	200/85	1,20	0,75	200	F ≤ 25 E ≤ 20 S ≤ 18	C = 500	0,13	0,04	125	TP50/70
	TD 200 F														
	DT 200 F														
	TZ 335 F	1000 ... 1300*	700	10000	500,00	335/85	1,15	0,42	200	G = 30 F = 25 E = 20	C = 500	0,08	0,02	125	TP50/70

PowerBLOCK modules are UL recognized

Common anode or cathode on request

* Highest voltage on request

¹⁾ $V_{RRM} \leq 1000$ V : $V_{RSM} = V_{RRM} + 50$ V

PowerBLOCK Fast Asymmetric Thyristor Modules

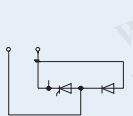
	Type	V_{DRM} V_{RRM} $V_{DSM} = V_{DRM}$	V_{RRM} V_{RRM} [($V_{RRM(C)}$) $t_p = 1\mu s$]	I_{TRMSM} A	I_{TSM} A 10 ms, $T_{vj\ max}$	$\int i^2 dt$ $A^2 \cdot s \cdot 10^3$ 10 ms, $T_{vj\ max}$	I_{TAVM}/T_c $A/^\circ C$ 180° el sin	$V_{(T0)}$ V $T_{vj} = T_{vj\ max}$	r_T m Ω $T_{vj} = T_{vj\ max}$	$(di/dt)_{cr}$ A/ μs DIN IEC 747 - 6	t_q μs typ.	$(dv/dt)_{cr}$ V/ μs DIN IEC 747 - 6	R_{thJC} $^\circ C/W$ 180° el sin	R_{thCK} $^\circ C/W$	$T_{vj\ max}$ $^\circ C$	outline / page
Baseplate = 20 mm	AD 50 F	1000 ... 1200*	15 [50]	120	1300	8,45	50/85	1,30	3,75	120	D ≤ 15 C ≤ 12 B ≤ 10	C = 500 F = 1000	0,45	0,16	125	TP20/70
	AD 60 F	1000 ... 1200*	15 [50]	150	1450	10,5	60/85	1,20	208	120	D ≤ 15 C ≤ 12 B ≤ 10	C = 500 F = 1000	0,39	0,16	125	TP20/70
Baseplate = 34 mm	AD 96 S	800 ... 1300*	15 [50]	200	2350	27,60	95/85	1,30	2,15	400	D ≤ 15 C ≤ 12 B ≤ 10	C = 500 F = 1000	0,23	0,06	125	TP34/70
	AD 116 S	800 ... 1200	15 [50]	220	2600	33,80	115/85	1,10	1,45	400	A ≤ 8 E ≤ 20 D ≤ 15	C = 500 F = 1000	0,23	0,06	125	TP34/70
Baseplate = 50 mm	AD 180 S	800 ... 1300*	15 [50]	350	4800	115,00	180/85	1,30	0,9	500	D ≤ 15 C ≤ 12 B ≤ 10	C = 500 F = 1000	0,13	0,04	125	TP50/70
	AD 220 S	800 ... 1300*	15 [50]	410	5200	135,00	220/85	1,10	0,6	500	A ≤ 8 F ≤ 25 E ≤ 20 D ≤ 15	C = 500 F = 1000	0,13	0,04	125	TP50/70

PowerBLOCK modules are UL recognized

* Highest voltage on request

PowerBLOCK Fast Diode Modules

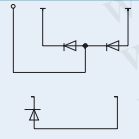
	Type	V_{RRM}	I_{FRMSM}	I_{FSM}	$\int i^2 dt$	I_{FAVM}/T_c	$V_{(TO)}$	r_T	I_{RM}	R_{thJC}	R_{thCK}	$T_{vj max}$	outline / page
		V	A	A	$A^2 \cdot 10^3$	$A/^\circ C$	V	$m\Omega$	A	$^\circ C/W$	$^\circ C/W$	$^\circ C$	
		V_{RSM} = $V_{RRM} + 100V$ (50 Hz)		10 ms, $T_{vj max}$	10 ms, $T_{vj max}$		$T_{vj} = T_{vj max}$	$T_{vj} = T_{vj max}$	$T_{vj} = T_{vj max}$ -di/dt = 100 A/ μs	180° el sin			
Baseplate = 20 mm	DD 46 S	800 ... 1200 ¹⁾	100	850	3,60	45/85	0,90	3,9		0,68	0,16	125	DP20/71
	DD 61 S	1000 ... 1400 ¹⁾	120	1600	12,80	61/100	1,00	2,2	82	0,62	0,16	150	DP20/71
	DD 62 S	400 ... 1000 ¹⁾	120	1600	12,80	61/100	1,00	2,2	62	0,62	0,16	150	DP20/71
	DD 81 S	1000 ... 1400	150	1900	18,05	81/100	0,95	1,7	87	0,48	0,16	150	DP20/71
	DD 82 S	400 ... 1000 ¹⁾	150	1900	18,05	81/100	0,95	1,7	65	0,48	0,16	150	DP20/71
Baseplate = 30 mm	DD 121 S	1000 ... 1400	200	2000	20,00	121/100	0,95	1,7	95	0,28	0,06	150	DP30/71
	DD122 S	400 ... 1000 ¹⁾	200	2000	20,00	121/100	0,95	1,7	70	0,28	0,06	150	DP30/71
Baseplate = 50 mm	DD 230 S	1800 ... 2600	410	7500	281,00	230/100	1,00	0,8		0,15	0,04	150	DP50/72
	ND 230 S	1800 ... 2600	410	7500	281,00	230/100	1,00	0,8		0,15	0,04	150	DP50/72
	DD 241 S	1000 ... 1400	410	7500	281,00	240/100	1,10	0,5	135	0,15	0,04	150	DP50/72
	ND 241 S	1000 ... 1400	410	7500	281,00	240/100	1,10	0,5	135	0,15	0,04	150	DP50/72
	DD 242 S	600 ... 1000 ¹⁾	410	7500	281,00	240/100	1,10	0,5	98	0,15	0,04	150	DP50/72
	ND 242 S	600 ... 1000 ¹⁾	410	7500	281,00	240/100	1,10	0,5	98	0,15	0,04	150	DP50/72

PowerBLOCK modules are UL recognized

Common anode or cathode on request

¹⁾ $V_{RRM} \leq 1000 V$: $V_{RSM} = V_{RRM} + 50 V$

IGBT and GCT – Freewheeling Diodes

Type 	$V_{(DRM)}$ V	$V_{(DID)}$ *) kV $T_c = 25$ typ.	$I_{(FSM)}$ kA sin, 10 ms $T_{vj\ max}$	$\int i^2 dt$ $A^2s \cdot 10^3$ sin, 10 ms $T_{vj\ max}$	$V_{(F)}/I_{(FM)}$ V/2,5 kA $T_{vj} = T_{vj\ max}$ sin	$I_{(RM)}$ A di/dt = 1000 A/ μ s $I_{(FM)} = 2,5$ kA $T_{vj} = T_{vj\ max}$	$Q_{(rr)}$ mAs di/dt = 1000 A/ μ s $I_{(FM)} = 2,5$ kA $T_{vj} = T_{vj\ max}$	R_{thJC} $^{\circ}C/W$ DC	$T_{vj\ max}$ $^{\circ}C$	outline / page
D 911 SH	4500	2,8	26	3380	6,0	1200**)	2,8**)	0,0100	140	D100.26K/82
D 1031 SH	4500	2,8	26	3380	4,2	1500**)	3,5**)	0,0100	140	D100.26K/82
D 1331 SH	4500	2,8	28	3920	4,2	1500**)	3,5**)	0,0075	140	D120.26K/82
■ D 1641 SX	4500	2,5	28	3920	3,1	1800***)	4,2***)	0,0075	140	D100.14K/82
■ D 1181 SX	6000	3,8	21	2200	4,0	1800***)	4,6***)	0,0100	140	D100.26K/82
■ D 1441 SX	6000	3,8	21	2200	4,0	1800***)	4,6***)	0,0075	140	D100.14K/82
D 931 SH	6500	3,2	16	1280	5,6	1300**)	3,5**)	0,0100	140	D100.26K/82
D 1131 SH	6500	3,2	22	2400	5,6	1300**)	3,5**)	0,0075	140	D120.26K/82
D 1951 SH	6500	3,2	44	9680	4,0	1500**)	4,3**)	0,0045	140	D150.26K/82

*) estimate failure rate $\lambda \sim 100$ fit

**) Clamp circuit $L = 0,25$ μ H

***) RCD - Snubber $C = 1$ μ F, $L = 0,1$ μ H

■ Not for new design

GTO – Freewheeling Diodes

Type 	$V_{(DRM)}$ V	$V_{(DID)}$ *) kV $T_c = 25$ typ.	$I_{(FSM)}$ kA sin, 10 ms $T_{vj\ max}$	$\int i^2 dt$ $A^2s \cdot 10^3$ sin, 10 ms $T_{vj\ max}$	$V_{(F)}/I_{(FM)}$ V/2,5 kA $T_{vj} = T_{vj\ max}$ sin	$I_{(RM)}$ **) A di/dt = 250 A/ μ s $I_{(FM)} = 1$ kA $T_{vj} = T_{vj\ max}$	$Q_{(rr)}$ **) mAs di/dt = 250 A/ μ s $I_{(FM)} = 1$ kA $T_{vj} = T_{vj\ max}$	$(-di/dt)_{com}$ a/ μ s	R_{thJC} $^{\circ}C/W$ DC	$T_{vj\ max}$ $^{\circ}C$	outline / page
D 1170 S	2000, 2500	1,25	24,0	2880	2,62/6,4	580	1,7	500	0,0184	120	D75.26K/81
D 721 S	3500 ... 4500	2,00	15,0	1130	3,5/2,5	600	1,7	500	0,0180	125	D76.26K/81
D 1461 S	3500 ... 4500	2,00	32,0	5120	2,5/2,5	840	2,8	500	0,0125	140	D100.26K/82
D 1251 S	4500	2,5	18,0	1620	2,5/2,5	800	3,0	550	0,0100	140	D76.14K/81
D 921 S	4500	2,5	32,0	5120	2,6/2,5	700	2,8	500	0,0125	140	D100.26K/82
D 1381 S	4500	3,00	32,0	5120	2,6/2,5	700	2,8	500	0,0125	140	D100.26K/82

■ Not for new design

*) Estimate failure rate $\lambda \sim 100$ fit

GTO-Snubber **) $V_{(R)} = 0,5 V_{(RM)}$, $V_{(RM)} = 0,8 V_{(RM)}$

Snubber Diodes

Type 	$V_{(RRM)}$ V	$V_{R(cr)}$ V ¹⁾	$I_{(FSM)}$ kA sin, 10 ms $T_{vj} = T_{vj,max}$	$V_{(F)/I_{(FM)}}$ V/kA sin, 10 ms $T_{vj} = T_{vj,max}$	V_{FRM} typ. V di/dt = 1000 A/μs $T_{vj} = T_{vj,max}$	R_{thJC} °C/W DC	$T_{vj,max}$ °C	outline / page
D 170 S	2500	1500	3,70	2,3/0,8		0,1800	140	DSW27.1/78
D 170 U	2500	1500	3,15	2,15/0,65		0,2500	140	DSW27.1/78
D 228 S	2500	1500	3,20	2,12/0,5		0,0750	125	D60.14/79
D 56 S	4500	3000	1,35	4,5/0,32	145	0,2450	125	DSW27.2/78
D 56 U	4500	3000	1,20	4,15/0,28	75	0,3250	125	DSW27.2/78
D 291 S	3500 ... 4500	3200	4,50	4,15/1,2	145	0,0400	125	D58.26K/81
D 841 S	4500	3200	15,00	3,5/2,5	75	0,0100	125	D58.26K/81
snubberless:								
■ D 271 S	4500	3200	4,30	4,15/1,2	180	0,0400	125	D58.26K/81
D 371 S	4500	3200	6,00	3,9/1,2	150	0,0350	125	D58.26K/81
D 801 S	4500	3200	14,00	3,7/2,5	85	0,0100	125	D76.14K/81
D 901 S	3500 ... 4500	2500	21,50	3,5/2,5	70	0,0125	125	D100.26K/82
D 281 S	6000	4500	5,00	5/1,2	280	0,0350	125	D58.26K/81
■ D 1101 S	6000	4500	17,00	6,6/2,5	200	0,0075	125	D100.26K/82

■ Not for new design

¹⁾ Maximum permissible link voltage, GTO snubber diode

Pulsed Power Applications

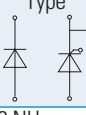
Type 	V_{BO} kV	V_{RRM} kV	V_{TM}/I_{TM} V/kA	I_{TSM} kA	di/dt _{cr(on)} ¹⁾ A/μs	di/dt _{cr(off)} ¹⁾ A/μs	R_{thJC} °C/W	$T_{vj,max}$ °C	outline / page
T 4003 NH	5,2	5,2	1,8/6	100	5000		0,0043	120	T172.40L/77
T 1503 NH	7,5	7,5 ... 8	3,0/4	40	5000		0,006	120	T150.40L/77
T 2563 NH	7,5	7,5 ... 8	2,96/6	56	5000		0,0043	120	T172.40L/77
D 2601 NH		9	4,9/4	32		7500	0,0075	120	D120.26K/82

Crow Bar Thyristors and Diodes

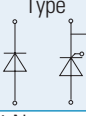
Type 	V_{DRM} kV	V_{RRM} kV	$V_{D,DC}$ kV	V_{TM}/I_{TM} V/kA	I_{TSM} kA	di/dt _{cr(on)} ¹⁾ A/μs	R_{thJC} °C/W	$T_{vj,max}$ °C	outline / page
T 1101 N	3	3	typ 1,5	2,0/4	29	1000	0,012	125	T100.26K/75
D 2201 N		4,5	typ 2,5	1,3/2,5	35		0,01	140	D100.26K/82

¹⁾ Single pulse

Overview Thyristors in Disc Housings

V_{DRM} - Concept

8000 V																	T1901N T1503N T1501N	T2561N T2563N
7000 V																		
5200 V																		
5000 V																		
4800 V																		
4400 V																		
4200 V	1200 V_{RMS}																	
4000 V																		
3800 V																		
3600 V	1100 V_{RMS}																	
3400 V																		
3200 V																		
2900 V																		
2600 V																		
2400 V																		
2200 V	690 V_{RMS}																	
2000 V																		
1800 V	550 V_{RMS}																	
1600 V																		
1400 V																		
1200 V	200 V_{RMS}																	
600 V																		
400 V																		
Pellet Ø	21 mm	23 mm	25 mm	30 mm	32 mm	38 mm	42 mm	46 mm	51 mm	55/56 mm	58 mm	65 mm	75 mm	80 mm	100 mm	119 mm		
Case Ø		41 mm		50 mm		57/60 mm			75 mm		100 mm		120 mm	110 mm	150 mm	170 mm		



High Power - Discs

Epoxy - Discs

Thyristors

up to 600 V														
Type	$V_{DRM}^{2)}$ V_{RRM} V $V_{DSM} = V_{DRM}$ $V_{RSM} = V_{RRM}$ 50 V	I_{TRMSM} A	$\int i^2 dt$ $A^2s \cdot 10^3$ 10 ms, $T_{vj\ max}$	I_{TSM} kA 10 ms, $T_{vj\ max}$	V_T/I_T V/kA $T_{vj\ max}$	I_{TAVM} $A/^\circ C$ 180°el sin $T_c = 85^\circ C$	$V_{(TO)}$ V $T_{vj} = T_{vj\ max}$	r_T $m\Omega$ $T_{vj} = T_{vj\ max}$	$(di/dt)_{cr}$ $A/\mu s$ DIN IEC 747 - 6	t_q μs typ.	$(dv/dt)_{cr}$ $V/\mu s$ DIN IEC 747 - 6	R_{thJC} $^\circ C/W$ 180°el sin	$T_{vj\ max}$ $^\circ C$	outline / page
T 210 N	200 ... 600	330	151	5,5	1,33/0,6	210	0,80	0,850	200	200	F = 1000	0,1500	140	TSW27/73
T 348 N	200 ... 600	600	80	4,0	1,92/1,1	348	1,00	0,700	200	200	F = 1000	0,1000	140	T41.14/74
T 398 N	200 ... 600	800	151	5,5	1,63/1,5	398	1,00	0,400	200	200	F = 1000	0,1000	140	T41.14/74
T 568 N	200 ... 600	900	225	6,7	1,76/2,0	568	0,80	0,440	200	200	F = 1000	0,0680	140	T41.14/74
T 828 N	200 ... 600	1500	720	12,0	1,65/2,5	828	1,00	0,230	300	150	F = 1000	0,0450	140	T50.14/74
T 1078 N	200 ... 600	2000	1050	14,5	1,81/3,5	1078	1,02	0,200	200	150	F = 1000	0,0330	140	T50.14/74
T 1258 N	200 ... 600	2500	2000	20,0	1,5/4,5	1258	1,00	0,100	120	200	F = 1000	0,0330	140	T60.14/74
T 2509 N	200 ... 600*	4900	8820	42,0 ¹⁾	1,22/6	2509	0,75	0,072	200	200	F = 1000	0,0184	140	T75.26/74
T 3709 N	200 ... 600*	7000	18000	60,0 ²⁾	1,50/15	3710	0,75	0,0475	200	200	F = 1000	0,0125	140	T100.26/74

up to 1800 V														
Type	$V_{DRM}^{2)}$ V_{RRM} V $V_{DSM} = V_{DRM}$ $V_{RSM} = V_{RRM}$ +100 V	I_{TRMSM} A	$\int i^2 dt$ $A^2s \cdot 10^3$ 10 ms, $T_{vj\ max}$	I_{TSM} kA 10 ms, $T_{vj\ max}$	V_T/I_T V/kA $T_{vj\ max}$	I_{TAVM} A 180°el sin $T_c = 85^\circ C$	$V_{(TO)}$ V $T_{vj} = T_{vj\ max}$	r_T $m\Omega$ $T_{vj} = T_{vj\ max}$	$(di/dt)_{cr}$ $A/\mu s$ DIN IEC 747 - 6	t_q μs typ.	$(dv/dt)_{cr}$ $V/\mu s$ DIN IEC 747 - 6	R_{thJC} $^\circ C/W$ 180°el sin	$T_{vj\ max}$ $^\circ C$	outline / page
T 86 N	1200 ... 1800*	200	20	2,00	1,99/0,4	86	1,00	2,60	150	200	F = 1000	0,3000	125	TSW27/73
T 130 N	1200 ... 1800	300	45	3,00	1,96/0,6	130	1,08	1,53	150	180	F = 1000	0,2000	125	TSW27/73 TFL36/73
T 160 N	1200 ... 1800	300	58	3,40	1,96/0,6	160	1,08	1,53	150	200	F = 1000	0,1500	125	TSW27/73 TFL36/73
T 178 N	1200 ... 1800	300	34	2,60	1,9/0,6	178	0,92	1,50	150	180	F = 1000	0,1400	125	T41.14/74
T 218 N	1200 ... 1800	400	58	3,40	2,2/0,8	218	0,90	1,35	150	200	F = 1000	0,1100	125	T41.14/74
T 221 N	1200 ... 1800	450	163	5,70	1,74/0,8	221	1,10	0,75	150	200	F = 1000	0,1200	125	TSW41/73 TFL54/73
T 298 N	600 ... 1600*	600	90,6	4,25	2,0/1,1	298	0,85	0,90	150	200	F = 1000	0,0880	125	T41.14/74
T 345 N	1200 ... 1800*	550	238	6,90	1,56/1,0	345	0,80	0,70	150	250	F = 1000	0,0800	125	TFL54/73
T 358 N	1200 ... 1800*	700	106	4,60	2,07/1,2	358	0,85	0,90	150	250	F = 1000	0,0680	125	T41.14/74
T 370 N	1200 ... 1800	650	320	8,00	1,65/1,2	370	0,80	0,50	200	250	F = 1000	0,0850	125	TSW41/73
T 378 N	1200 ... 1600*	800	202	6,35	1,85/1,2	378	0,80	0,75	150	250	F = 1000	0,0680	125	T41.14/74
T 388 N	1200 ... 1800*	730	205	6,40	2,1/1,5	388	0,90	0,75	120	220	F = 1000	0,0680	125	T50.14/74
T 508 N	1200 ... 1800*	800	238	6,90	1,92/1,6	510	0,80	0,60	120	250	F = 1000	0,0530	125	T50.14/74
T 509 N	1200 ... 1800*	800	238	6,90	1,92/1,6	510	0,80	0,60	120	250	F = 1000	0,0530	125	T57.26/74

■ Not for new design

◆ New type

* Highest voltage on request

¹⁾ Case rapture current 32 kA (sinusoidal half wave 50 Hz)²⁾ Case rapture current 36 kA

Thyristors

up to 1800 V														
Type	V_{DRM} V_{RRM} V $V_{DSM} = V_{DRM}$ $V_{RSM} = V_{RRM}$ 50 V	I_{TRMSM} A	$\int i^2 dt$ $A^2s \cdot 10^3$ 10 ms $T_{vj\ max}$	I_{TSM} kA 10 ms $T_{vj\ max}$	V_T/I_T V/kA $T_{vj\ max}$	I_{TAVM} A 180 ° el sin $T_c = 85\ ^\circ C$	$V_{(TO)}$ V $T_{vj} = T_{vj\ max}$	r_T m Ω $T_{vj} = T_{vj\ max}$	$(di/dt)_{cr}$ A/ μs DIN IEC 747 - 6	t_q μs typ.	$(dv/dt)_{cr}$ V/ μs DIN IEC 747 - 6	R_{thJC} $^\circ C/W$ 180 ° el sin	$T_{vj\ max}$ $^\circ C$	outline / page
T 588 N	1200 ... 1800*	1250	320	8,0	2,15/2,4	588	0,800	0,5000	200	250	F = 1000	0,0450	125	T50.14/74
T 589 N	1200 ... 1800*	1250	320	8,0	2,15/2,4	588	0,800	0,5000	200	250	F = 1000	0,0450	125	T57.26/74
T 618 N	1200 ... 1400	1250	451	9,5	1,75/2,0	618	0,800	0,4200	200	250	F = 1000	0,0450	125	T50.14/74
T 619 N	1200 ... 1400	1250	451	9,5	1,75/2,0	618	0,800	0,4200	200	250	F = 1000	0,0450	125	T57.26/74
T 648 N	1200 ... 1600	1300	605	11,0	2,1/2,5	649	1,000	0,3800	120	250	F = 1000	0,0380	125	T60.14/74
T 649 N	1200 ... 1600	1300	605	11,0	2,1/2,5	649	1,000	0,3800	120	250	F = 1000	0,0380	125	T57.26/74
T 718 N	1200 ... 1600*	1500	781	12,5	1,94/3,0	718	0,850	0,3500	120	250	F = 1000	0,0380	125	T60.14/74
T 719 N	1200 ... 1600*	1500	781	12,5	1,94/3,0	718	0,850	0,3500	120	250	F = 1000	0,0380	125	T57.26/74
T 878 N	1200 ... 1800	1750	1200	15,5	1,95/3,6	879	0,850	0,2700	200	250	F = 1000	0,0320	125	T60.14/74
T 879 N	1200 ... 1800	1750	1200	15,5	1,95/3,6	879	0,850	0,2700	200	250	F = 1000	0,0320	125	T57.26/74
T 1049 N	1200 ... 1800	1870	1280	16,0	1,34/1,8	1050	0,850	0,2250	200	250	F = 1000	0,0265	125	T75.26/74
T 1189 N	1200 ... 1800	2800	2530	22,5	2,05/5,4	1190	0,900	0,1900	200	240	F = 1000	0,0230	125	T75.26/74
T 1500 N	1200 ... 1800	3500	5611	33,5 ²⁾	2,1/7,0	1500	0,900	0,1500	200	240	C = 500	0,0184	125	T75.26K/75
T 1509 N	1200 ... 1800	3500	5611	33,5 ²⁾	2,1/7,0	1500	0,900	0,1500	200	240	F = 1000	0,0184	125	T75.26/74
T 1989 N	1200 ... 1800	4200	6480	36,0	2,05/8,0	1990	0,900	0,1200	200	250	C = 500	0,0133	125	T120.26K/75
T 3159 N	1200 ... 1800	7000	16245	57,0 ¹⁾	1,37/6,0	3160	0,850	0,0820	200	250	F = 1000	0,0850	125	T110.26/74

■ Not for new design

◆ New type

* Highest voltage on request

¹⁾ Case rapture current 38 kA (sinusoidal half wave 50 Hz)

²⁾ Case rapture current 32 kA

Thyristors

up to 3000 V															
Type	V_{DRM} V_{RRM} V $V_{DSM} = V_{DRM}$ $V_{RSM} = V_{RRM}$ 50 V	I_{TRMSM} A	$\int i^2 dt$ $A^2s \cdot 10^3$ 10 ms T_{vjmax}	I_{TSM} kA 10 ms T_{vjmax}	V_T/I_T V/kA T_{vjmax}	I_{TAVM} A 180 ° el sin $T_c = 85 °C$	$V_{(TO)}$ V $T_{vj} = T_{vjmax}$	r_T m Ω $T_{vj} = T_{vjmax}$	$(di/dt)_{cr}$ A/ μs DIN IEC 747 - 6	t_q μs typ.	$(dv/dt)_{cr}$ V/ μs DIN IEC 747 - 6	R_{thJC} °C/W 180 ° el sin	T_{vjmax} °C	outline / page	
■ T 271 N	2000 ... 2500	650	245	7,0	2,35/1,2	270	1,070	0,870	60	300	C = 500 F = 1000	0,0910	125	TSW41/73	
T 308 N	2000 ... 2600*	550	101	4,5	2,88/1,1	308	1,100	1,600	60	350	C = 500 F = 1000	0,0560	125	T50.14/74	
T 458 N	2000 ... 2600	1000	405	9,0	2,75/2,0	459	1,000	0,840	120	300	C = 500 F = 1000	0,0455	125	T60.14/74	
T 459 N											F = 1000			T57.26/74	
T 639 N	1800 ... 2200	1250	562	10,6	1,88/1,8	640	0,850	0,510	120	400	F = 1000	0,0377	125	T57.26/74	
T 658 N	2200 ... 2600	1500	660	11,5	2,53/2,85	659	1,000	0,500	150	300	F = 1000	0,0330	125	T60.14/74	
T 659 N	2200 ... 2600	1500	660	11,5	2,53/2,85	659	1,000	0,500	150	300	F = 1000	0,0330	125	T57.26/74	
T 699 N	1800 ... 2200	1500	744	12,2	2,32/2,85	699	0,950	0,450	200	300	F = 1000	0,0320	125	T57.26/74	
T 708 N	1800 ... 2200	1500	744	12,2	2,32/2,85	699	0,950	0,450	200	300	F = 1000	0,0320	125	T60.14/74	
T 709 N	2000 ... 2600	1500	845	13,0	2,84/3,0	700	1,050	0,530	50	300	C = 500 F = 1000	0,0290	125	T75.26/74	
T 829 N	2000 ... 2600	1800	1201	15,5	1,78/1,8	829	0,950	0,425	50	350	F = 1000	0,0265	125	T75.26/75	
T 1039 N	1800 ... 2200	2200	1711	18,5	1,53/2	1039	0,90	0,300	200	300	F = 1000	0,0231	125	T75.26/75	
T 1219 N	2000 ... 2800	2625	2531	22,5	1,38/1,0	1220	1,000	0,275	150	350	F = 1000	0,0184	125	T75.26/75	
T 1329 N	1800 ... 2200	2600	2645	23,0	1,13/1,0	1329	0,900	0,234	200	300	F = 1000	0,0184	125	T75.26/75	
T 1589 N	2000 ... 2800*	3200	3920	28,0	2,45/5,0	1589	1,100	0,237	150	400	C = 500 F = 1000	0,0124	125	T100.26/76	
T 1869 N	1800 ... 2200	4100	6125	35,0	2,2/8,0	1869	0,900	0,155	200	300	F = 1000	0,0133	125	T100.26/76	
■ T 2101 N	2000 ... 2600	5000	10100	45,0	1,2/2,0	2200	0,920	0,139	150	250	F = 1000	0,0107	125	T120.35K.2/76	
T 2156 N	2000 ... 2800	4600	8000	40,0 ¹⁾	2,65/8,8	2159	1,050	0,154	150	400	C = 500	0,0099	125	T110.35/74	
T 2159 N	2000 ... 2800	4600	8000	40,0 ¹⁾	2,65/8,8	2159	1,050	0,154	150	400	F = 1000	0,0099	125	T110.26/74	
T 2160 N	2200 ... 2800	4600	8000	40,0	2,65/8,8	2159	1,050	0,154	150		F = 1000	0,0099	125	T120.26K/75	
T 2476 N	2200 ... 2800	5100	9460	43,5 ¹⁾	1,43/3,0	2480	0,950	0,154	200	400	C = 500 F = 1000	0,0085	125	T110.35/74	
T 2479 N	2200 ... 2800	5100	9460	43,5 ¹⁾	1,43/3,0	2480	0,950	0,154	200	400	F = 1000	0,0085	125	T110.26/74	
T 2480 N	2200 ... 2800	5100	9460	43,5	1,43/3,0	2480	0,950	0,154	200	400	F = 1000	0,0085	125	T120.26K/75	
T 2709 N	1600 ... 2200	5800	12500	50,0 ¹⁾	2,35/11	2709	0,900	0,125	200	300	F = 1000	0,0085	125	T110.26/74	
T 2710 N	1600 ... 2200	5800	12500	50,0	2,35/11	2709	0,900	0,125	200	300	F = 1000	0,0085	125	T120.26K/75	
T 4301 N	2200 ... 2900	9600	40500	90,0	1,14/4	4460	0,821	0,0774	300	250	F = 1000	0,0053	125	T150.35K/76	
T 4771 N	2200 ... 2900	10200	40500	90,0	1,14/4	4770	0,821	0,0774	300	250	F = 1000	0,0048	125	T150.26K/76	

■ Not for new design

* Highest voltage on request

¹⁾ Case rupture current 38 kA (sinusoidal half wave 50 Hz)

Thyristors

up to 4500 V														
Type 	V_{DRM} V_{RRM} V $V_{DSM} = V_{DRM}$ $V_{RSM} = V_{RRM} + 100$ V	I_{TRMSM} A	$\int i^2 dt$ $A^2s \cdot 10^3$ 10 ms $T_{vj\ max}$	I_{TSM} kA 10 ms $T_{vj\ max}$	V_T/I_T V/kA $T_{vj\ max}$	I_{TAVM} A 180 ° el sin $T_c = 85$ °C	$V_{(T0)}$ V $T_{vj} = T_{vj\ max}$	r_T mΩ $T_{vj} = T_{vj\ max}$	$(di/dt)_{cr}$ A/μs DIN IEC 747 - 6	t_q μs typ.	$(dv/dt)_{cr}$ V/μs DIN IEC 747 - 6	R_{thJC} °C/W 180 ° el sin	$T_{vj\ max}$ °C	outline / page
T 379 N	3600 ... 4200	800	205	6,4	3,26/1,2	422	1,20	1,600	100	500	F = 1000 C = 500	0,033	125	T57.26/74
T 380 N	3200 ... 3800	750	211	6,5	2,8/1,2	380	1,20	1,200	100	350	F = 1000	0,045	125	T57.26K/75
■ T 860 N	3000 ... 3600	2000	1445	17,0	3,18/3,8	860	1,08	0,500	80	400	C = 500	0,0210	125	T75.26K/75
T 869 N											F = 1000			T75.26/74
T 901 N	2800 ... 3600	2050	1445	17,0	1,75/1,2	950	1,16	0,494	150	300	F = 1000	0,0180	125	T76.26K/75
T 909 N														T75.26/74
T 929 N	3000 ... 3600	2200	1530	17,5	2,7/3,6	930	1,00	0,430	80	500	C = 500 F = 1000	0,0215	125	T75.26/74
T 1601 N	2800 ... 3600	4050	7400	38,5	1,5/2,0	1900	1,00	0,250	300	300	F = 1000	0,0097	125	T120.35K.2/76
T 1929 N	3000 ... 3800	4200	6850	37,0	2,9/8,0	1930	1,08	0,200	150	450	C = 500 F = 1000	0,0099	125	T110.26/74
T 2001 N	2800 ... 3600	4350	7400	38,5	1,5/2,0	2050	1,00	0,250	300	300	F = 1000	0,0087	125	T120.26K.1/75
T 2009 N	2800 ... 3600	4350	7400	39,5 ¹⁾	3,5/2	2050	1,00	0,250	300	300	F = 1000	0,0087	125	T110.26/74
T 3401 N	3100 ... 3600	7500	28000	75,0	1,4/4	3550	0,82	0,145	300	300	F = 1000	0,0054	125	T150.35K/76
T3801 N	3100 ... 3600	8000	28000	75	1,4/4	3810	0,82	0,145	300	300	F = 1000	0,0048	125	T150.35K/76
T 729 N	3600 ... 4200	1840	1250	15,8	3,4/3,5	730	1,20	0,570	80	400	F = 1000	0,0215	120	T75.26/74
T 730 N	3600 ... 4200	1840	1250	15,8	3,4/3,5	730	1,20	0,570	80	400	F = 1000	0,0215	120	T75.26K/75
T 731 N	3600 ... 4400	1980	1280	16,0	1,75/1,2	925	1,10	0,542	300	400	H = 2000	0,0185	125	T76.26K/75
T 739 N	3600 ... 4400	1980	1280	16,0	1,75/1,2	925	1,10	0,542	300	400	H = 2000	0,0185	125	T75.26/74
T 1401 N	3600 ... 4400	3450	5100	32,0	1,95/2,0	1600	1,29	0,330	300	350	H = 2000	0,0096	125	T120.35K.2/76
T 1971 N	3600 ... 4400	3700	5100	32,0	1,95/2,0	1730	1,29	0,330	300	350	H = 2000	0,0086	125	T120.26K.1/75
◆ T 3101 N	4000 ... 4400	6500	21000	65,0	1,75/4	3080	1,01	0,185	300	400	H = 2000	0,0054	125	T150.35K/76

■ Not for new design

◆ New type

¹⁾ Case rupture current 38 kA (sinusoidal half wave 50 Hz)

Thyristors

up to 5500 V														
Type	V_{DRM} V_{RRM} V $V_{DSM} = V_{DRM}$ $V_{RSM} = V_{RRM} + 100$ V	I_{TRMSM} A	$\int i^2 dt$ $A^2s \cdot 10^3$ 10 ms $T_{vj\ max}$	I_{TSM} kA 10 ms $T_{vj\ max}$	V_T/I_T V/kA $T_{vj\ max}$	I_{TAVM} A 180 ° el sin $T_c = 85$ °C	$V_{(T0)}$ V $T_{vj} = T_{vj\ max}$	r_T m Ω $T_{vj} = T_{vj\ max}$	$(di/dt)_{cr}$ A/ μ s DIN IEC 747 - 6	t_q μ s typ.	$(dv/dt)_{cr}$ V/ μ s DIN IEC 747 - 6	R_{thJC} °C/W 180 ° el sin	$T_{vj\ max}$ °C	outline / page
T 1451 N	4800 ... 5200	3550	4000	28,5	1,7/2,0	1680	0,92	0,370	300	450	H = 2000	0,0097	125	T120.35K.2/76
T 1551 N	4800 ... 5200	3800	4000	28,5	1,7/2,0	1810	0,92	0,370	300	450	H = 2000	0,0086	125	T120.26K.1/75
◆ T 2161 N	4800 ... 5200	4700	14600	54,0	1,85/3,0	2160	0,81	0,360	300	450	H = 2000	0,0075	125	T120.35K/76
◆ T 2351 N	4800 ... 5200	5000	14600	54,0	1,85/3,0	2350	0,81	0,360	300	450	H = 2000	0,0064	125	T120.26K/75
T 2401 N	4800 ... 5200	5900	12500	50,0	1,95/4,0	2800	0,99	0,240	300	350	H = 2000	0,0054	125	T150.35K/76
T 2851 N	4800 ... 5200	6800	21000	65,0	1,65/4,0	3200	0,97	0,170	300	600	H = 2000	0,0054	125	T150.35K/76
◆ T 4001 N	4800 ... 5350	8200	50000	100,0	1,8/6	3880	0,92	0,142	150	550	H = 2000	0,00453	120	T172.40K/76

6000 V and more

Type	V_{DRM} V_{RRM} V $V_{DSM} = V_{DRM}$ $V_{RSM} = V_{RRM} + 100$ V	I_{TRMSM} A	$\int i^2 dt$ $A^2s \cdot 10^3$ 10 ms $T_{vj\ max}$	I_{TSM} kA 10 ms $T_{vj\ max}$	V_T/I_T V/kA $T_{vj\ max}$	I_{TAVM} A 180 ° el sin $T_c = 85$ °C	$V_{(T0)}$ V $T_{vj} = T_{vj\ max}$	r_T m Ω $T_{vj} = T_{vj\ max}$	$(di/dt)_{cr}$ A/ μ s DIN IEC 747 - 6	t_q μ s typ.	$(dv/dt)_{cr}$ V/ μ s DIN IEC 747 - 6	R_{thJC} °C/W 180 ° el sin	$T_{vj\ max}$ °C	outline / page
T 201 N	6000 ... 7000	510	88,2	4,2	3,40/0,5	245	1,29	4,180	300	600	H = 2000	0,0430	125	T58.26K/75
T 501 N	6000 ... 7000	1350	845	13,0	2,65/1,0	640	1,30	1,350	300	650	H = 2000	0,0185	125	T76.26K/75
T 551 N	6000 ... 7000	1260	845	13,0	2,65/1,0	600	1,30	1,350	300	650	H = 2000	0,0200	125	T76.35K/75
T 1081 N	6000 ... 7000	2700	5780	34,0	2,7/2,0	1300	1,18	0,759	300	600	H = 2000	0,0086	125	T120.26K.1/75
T 1201 N	6000 ... 7000	2520	5780	34,0	2,7/2,0	1200	1,18	0,759	300	600	H = 2000	0,0096	125	T120.35K.1/76
T 1851 N	6000 ... 7000	4000	11500	48,0	2,65/3	1850	1,22	0,490	300	600	H = 2000	0,0064	125	T120.26K/75
T 1901 N	7000 ... 8000	4400	8000	40,0	3,0/4,0	2100	1,24	0,440	300	550	H = 2000	0,0054	125	T150.35K/76
T 2561 N	7500 ... 8000	5600	15700	56,0	2,95/6,0	2560	1,28	0,278	300	550	H = 2000	0,0046	125	T172.40K/76

■ Not for new design

◆ New type

Thyristors

Light Triggered Thyristors															
Type	V_{BO} V	V_{RRM} V	I_{TRMSM} A	$\int i^2 dt$ $A^2s \cdot 10^3$ 10 ms $T_{vj\ max}$	I_{TSM} kA 10 ms $T_{vj\ max}$	V_T/I_T V/kA $T_{vj\ max}$	I_{TAVM} A 180° el sin $T_c = 85\ ^\circ C$	$V_{(TO)}$ V $T_{vj} = T_{vj\ max}$	r_T m Ω $T_{vj} = T_{vj\ max}$	$(di/dt)_{cr}$ A/ μs DIN IEC 747 - 6	t_q μs typ.	$(dv/dt)_{cr}$ V/ μs DIN IEC 747 - 6	R_{thJC} $^\circ C/W$ 180° el sin	$T_{vj\ max}$ $^\circ C$	outline / page
◆ T 553 N	6500	7000	1200	684	11,7	2,65/1,0	550	1,30	1,35	300	650	H = 2000	0,0200	120	T76.35L/77
T 1503 N	7500	7500 ... 8000	3800	8000	40,0	3,0/4,0	1760	1,24	0,44	300	550	H = 2000	0,0063	120	T150.40L/77
T 2563 N	7500	7500 ... 8000	5600	15700	56,0	2,95/6,0	2560	1,28	0,278	300	550	H = 2000	0,0046	120	T172.40L/77
◆ T 4003 N	5200	5200	8130	50000	100,0	1,8/6,0	3845	0,92	0,142	300	550	H = 2000	0,0046	120	T172.40L/77

◆ New type

Fast Thyristors

up to 800 V															
Type	V_{DRM}, V_{RRM} $V_{DSM} = V_{DRM}$ $V_{RSM} = V_{RRM} + 50\ V$	I_{TRMSM} A	I_{TSM} kA 10 ms, $T_{vj\ max}$	V_T/I_T V/kA $T_{vj\ max}$	$V_{(TO)}$ V $T_{vj} = T_{vj\ max}$	r_T m Ω $T_{vj} = T_{vj\ max}$	$(di/dt)_{cr}$ A/ μs DIN IEC 747 - 6	t_q μs typ.	$(dv/dt)_{cr}$ V/ μs DIN IEC 747 - 6	V_{GT} V $T_{vj} = 25\ ^\circ C$	I_{GT} mA $T_{vj} = 25\ ^\circ C$	R_{thJC} $^\circ C/W$ 180° el sin	$T_{vj\ max}$ $^\circ C$	outline / page	
■ T 72 F	400 ... 600	200	2,05	2,1/0,4	1,25	1,8	200	S ≤ 18 D ≤ 15	B = 50 C* = 500 L = 500	2,0	150	0,350	125	TSW27/73	
■ T 102 F	200 ... 600	220	2,75	1,95/0,5	1,20	1,4	200	D ≤ 15	B = 50 C* = 500 L = 500 M* = 1000	2,0	150	0,260	125	TSW27/73	
T 178 F	200 ... 600	300	1,90	1,85/0,5	1,02	1,55	300	E ≤ 20 D ≤ 15 C* ≤ 12 ²⁾	B = 50 C = 500	2,0	200	0,180	140	T41.14/74	
T 308 F	200 ... 600	600	4,00	1,9/1,0	1	0,7	300	E ≤ 20 D ≤ 15 ²⁾	C* = 500 M* = 1000	2,0	200	0,108	140	T41.14/73	

■ Phase out type

* Large quantities on request

¹⁾ At $V_{RRM} < 800\ V + 50\ V$

²⁾ Only in connection with $(dv/dt)_{cr} = B$ or C

Fast Thyristors

up to 800 V															
Type	V_{DRM}, V_{RRM} $V_{DSM} = V_{DRM}$ $V_{RSM} = V_{RRM} + 50$ V	I_{TRMSM} A	I_{TSM} kA 10 ms, T_{vjmax}	V_T/I_T V/kA T_{vjmax}	$V_{(T0)}$ V $T_{vj} = T_{vjmax}$	r_T m Ω $T_{vj} = T_{vjmax}$	$(di/dt)_{cr}$ A/ μ s DIN IEC 747 - 6	t_q μ s typ.	$(dv/dt)_{cr}$ V/ μ s DIN IEC 747 - 6	V_{GT} V $T_{vj} = 25$ °C	I_{GT} mA $T_{vj} = 25$ °C	R_{thJC} °C/W 180 ° el sin	T_{vjmax} °C	outline / page	
T 698 F	200 ... 600	1100	11,00	1,65/2,0	1,02	0,32	300	E ≤ 20 D ≤ 15 C* ≤ 12 ²⁾	C* = 500 M* = 1000	2,0	200	0,0500	140	T50.14/74	
T 1078 F	200 ... 400	2000	14,50	1,81/3,5	1,02	0,2	200	S ≤ 18 D ≤ 15 C* ≤ 12	C* = 500 M* = 1000	2,0	250	0,0330	140	T50.14/74	

up to 1400 V															
Type	V_{DRM}, V_{RRM} $V_{DSM} = V_{DRM}$ $V_{RSM} = V_{RRM} + 50$ V	I_{TRMSM} A	I_{TSM} kA 10 ms, T_{vjmax}	V_T/I_T V/kA T_{vjmax}	$V_{(T0)}$ V $T_{vj} = T_{vjmax}$	r_T m Ω $T_{vj} = T_{vjmax}$	$(di/dt)_{cr}$ A/ μ s DIN IEC 747 - 6	t_q μ s typ.	$(dv/dt)_{cr}$ V/ μ s DIN IEC 747 - 6	V_{GT} V $T_{vj} = 25$ °C	I_{GT} mA $T_{vj} = 25$ °C	R_{thJC} °C/W 180 ° el sin	T_{vjmax} °C	outline / page	
■ T 80 F	1200 ... 1300*	200	2,45	2,4/0,4	1,30	2,40	160	F ≤ 25 E ≤ 20 S ≤ 18	B = 50 C* = 500 L = 500 M* = 1000	2,0	150	0,280	125	TSW27/73	
■ T 120 F	1200 ... 1300*	240	2,90	2,2/0,5	1,20	1,60	160	F ≤ 25 E ≤ 20 S ≤ 18 ²⁾	B = 50 C* = 500 L = 500 M* = 1000	2,0	150	0,200	125	TSW27/73	
T 128 F	1200 ... 1300*	300	2,45	2,6/0,6	1,28	2,15	160	F ≤ 25 E ≤ 20 S ≤ 18 ²⁾	B = 50 C* = 500 L = 500 M* = 1000	2,0	150	0,163	125	T41.14/74	
T 188 F	1000 ... 1300*	400	2,90	2,44/0,8	1,20	1,35	160	F ≤ 25 E ≤ 20 S ≤ 18 ²⁾	B = 50 C* = 500 L = 500 M* = 1000	2,0	150	0,117	125	T41.14/74	

■ Phase out type

* on request

²⁾ Only in connection with $(dv/dt)_{cr} = B$ or C

Fast Thyristors

up to 1400 V														
Type 	V_{DRM}, V_{RRM} $V_{DSM} = V_{DRM}$ $V_{RSM} = V_{RRM} + 50$ V	I_{TRMSM} A	I_{TSM} kA 10 ms, $T_{vj\ max}$	V_T/I_T V/kA $T_{vj\ max}$	$V_{(T0)}$ V $T_{vj} = T_{vj\ max}$	r_T m Ω $T_{vj} = T_{vj\ max}$	$(di/dt)_{cr}$ A/ μ s DIN IEC 747 - 6	t_q μ s typ.	$(dv/dt)_{cr}$ V/ μ s DIN IEC 747 - 6	V_{GT} V $T_{vj} = 25^\circ\text{C}$	I_{GT} mA $T_{vj} = 25^\circ\text{C}$	R_{thJC} $^\circ\text{C}/\text{W}$ 180 $^\circ$ el sin	$T_{vj\ max}$ $^\circ\text{C}$	outline / page
■ T 290 F	1000 ... 1300	550	6,40	2,1/1,0	1,20	0,75	200	F \leq 25 E \leq 20 S \leq 18 ²⁾	C* = 500 M* = 1000	2,2	250	0,080	125	TFL54/73
T 318 F	1000 ... 1200*	700	6,00	2,25/1,2	1,30	0,70	200	F \leq 25 E \leq 20 S \leq 18 ²⁾	B = 50 C* = 500 L = 500 M* = 1000	2,2	250	0,068	125	T50.14/74
■ T 320 F	1000 ... 1300*	600	9,15	1,95/1,2	1,15	0,42	200	F \leq 25 G \leq 30	B = 50 C* = 500 L = 500 M* = 1000	2,2	250	0,085	125	TSW41/73
T 340 F	1000 ... 1400	600	6,40	1,65/1,0	0,90	0,70	200	N \leq 60	C* = 500 L = 500 M* = 1000	2,2	250	0,080	125	TFL54/73
T 408 F	1000 ... 1200*	750	6,40	2,20/1,4	1,20	0,63	200	F \leq 25 E \leq 20 S \leq 18 ²⁾	C* = 500 L = 500 M* = 1000	2,2	250	0,0530	125	T50.14/74
■ T 599 F	1200 ... 1300*	1500	10,00	1,66/1,0	1,15	0,42	200	G \leq 30	B = 50 C* = 500	2,2	250	0,0380	125	T57.26/74
■ T 600 F	1200 ... 1300*	1500	10,00	1,66/1,0	1,15	0,42	200	F \leq 25 E \leq 20 ²⁾	L = 500 M* = 1000	2,2	250	0,0380	125	T57.26K/75
■ T 1052 S	1000 ... 1200	2200	20,00	2,70/4,0	1,45	0,3	400	F \leq 25 E \leq 20 D \leq 15 C* \leq 12 ²⁾	B = 50 C* = 500 L = 500 M* = 1000	2,2	300	0,0180	125	T75.26K/75

■ Phase out type

¹⁾ At $V_{RRM} < 800$ V + 50 V

* Large quantities on request

²⁾ Only in connection with $(dv/dt)_{cr} = B$ or C

Fast Thyristors

up to 2000 V														
Type	V_{DRM}, V_{RRM} $V_{DSM} = V_{DRM}$ $V_{RSM} = V_{RRM} + 50 \text{ V}$	I_{TRMSM} A	I_{TSM} kA 10 ms, $T_{vj\max}$	V_T/I_T V/kA $T_{vj\max}$	$V_{(TO)}$ V $T_{vj} = T_{vj\max}$	r_T m Ω $T_{vj} = T_{vj\max}$	$(di/dt)_{cr}$ A/ μ s DIN IEC 747 - 6	t_q μ s typ.	$(dv/dt)_{cr}$ V/ μ s DIN IEC 747 - 6	V_{GT} V $T_{vj} = 25^\circ\text{C}$	I_{GT} mA $T_{vj} = 25^\circ\text{C}$	R_{thJC} $^\circ\text{C}/\text{W}$ 180° el sin	$T_{vj\max}$ $^\circ\text{C}$	outline / page
T 930 S	1600 ... 2000*	2000	18,00	2,70/3,5	1,35	0,33	250	N ≤ 60 M ≤ 50 L ≤ 45 K ≤ 40 ²⁾	B = 50 C* = 500 L = 500 M* = 1000	2,2	250	0,0210	125	T75.26K/75

■ Phase out type

¹⁾ At $V_{RRM} < 800 \text{ V} + 50 \text{ V}$

* on request

²⁾ Only in connection with $(dv/dt)_{cr} = B$ or C

Fast Asymmetric Thyristors

Type	V_{DRM} V $V_{DSM} = V_{DRM}$	V_{RRM} V ($V_{RRM(C)}$) $tp = 1 \mu\text{s}$	I_{TRMSM} A	I_{TSM} kA 10 ms $T_{vj\max}$	V_T/I_T V/kA $T_{vj\max}$	$V_{(TO)}/r_T$ V/m Ω $T_{vj} = T_{vj\max}$	$(di/dt)_{cr}$ A/ μ s DIN IEC 747 - 6	t_q ¹⁾ μ s typ.	$(dv/dt)_{cr}$ V/ μ s DIN IEC 747 - 6	V_{GT} V $T_{vj} = 25^\circ\text{C}$	I_{GT} mA $T_{vj} = 25^\circ\text{C}$	R_{thJC} $^\circ\text{C}/\text{W}$ 180° el sin	$T_{vj\max}$ $^\circ\text{C}$	outline / page
A 158 S	1000 ... 1300*	15 (50)	400	2,45	2,60/0,6	1,3/2	400	D ≤ 15 C ≤ 12 B ≤ 10 A ≤ 8 ²⁾	C = 500 F = 1000	2,7	300	0,117	125	T41.14/74
A 198 S	1000 ... 1300*	15 (50)	400	2,70	2,0/0,25	1,1/1,3	400	E ≤ 20	C = 500 F = 1000	2,7	300	0,117	125	T41.14/74
A 358 S	1000 ... 1300*	15 (50)	800	5,00	2,75/1,5	1,3/0,9	500	D ≤ 15 C ≤ 12 B ≤ 10 A ≤ 8 ²⁾	C = 500 F = 1000	2,7	300	0,053	125	T50.14/74
A 438 S	1000 ... 1300*	15 (50)	900	5,50	2,1/1,5	1,1/0,6	500	F ≤ 25 E ≤ 20 D ≤ 15	C = 500 F = 1000	2,7	300	0,053	125	T50.14/74

■ Not for new design

¹⁾ With fast inverse diode

* on request

²⁾ $V_{DRM} \leq 1000 \text{ V}$

Diodes

up to 1000 V										
Type	V_{RRM} V $V_{RSM} = V_{RRM} + 100$ V	I_{FRMSM} A	I_{FSM} kA 10 ms, $T_{vj\ max}$	J^2dt $A^2s \cdot 10^3$ 10 ms $T_{vj\ max}$	I_{FAVM}/T_c $A/^\circ C$ 180° sinus	$V_{(TO)}$ V $T_{vj} = T_{vj\ max}$	r_T $m\Omega$ $T_{vj} = T_{vj\ max}$	R_{thJC} $^\circ C/W$ 180° el sin	$T_{vj\ max}$ $^\circ C$	outline / page
D 255 N	200 ... 800*	400	4,6	105,8	255/110	0,65	0,850	0,2300	180	DSW27/78
■ D 255 K	200 ... 800*	400	4,0	80,0	255/75	0,65	0,850	0,3450	180	DSW27/78
D 448 N	200 ... 800*	710	5,1	130,0	450/122	0,70	0,510	0,1020	180	D41.14/79
D 758 N	400 ... 800*	1195	8,8	387,2	760/115	0,70	0,310	0,0670	180	D41.14/79
D 2228 N	200 ... 800*	4000	28,5	4061,0	2230/110	0,70	0,0975	0,0254	180	D60.14/79
D 4457 N	400 ... 600	7000	52,0	13500,0	4460/111	0,70	0,047	0,0128	180	D60.8/79
D 5807 N	400 ... 600	9100	70,0	24500,0	5800/108	0,70	0,040	0,0098	180	D73.8/79
D 5809 N	400 ... 600	9100	70,0	24500,0	5800/58	0,70	0,040	0,0166	180	D75.26/80
D 8019 N	200 ... 600	13300	95,0	45000,0	8020/56	0,70	0,027	0,0125	180	D100.26/80

up to 2000 V										
Type	V_{RRM} V $V_{RSM} = V_{RRM} + 100$ V	I_{FRMSM} A	I_{FSM} kA 10 ms, $T_{vj\ max}$	J^2dt $A^2s \cdot 10^3$ 10 ms $T_{vj\ max}$	I_{FAVM}/T_c $A/^\circ C$ 180° sinus	$V_{(TO)}$ V $T_{vj} = T_{vj\ max}$	r_T $m\Omega$ $T_{vj} = T_{vj\ max}$	R_{thJC} $^\circ C/W$ 180° el sin	$T_{vj\ max}$ $^\circ C$	outline / page
D 798 N	1200 ... 1800	1650	11,8	696,0	800/130	0,81	0,28	0,046	180	D50.14/79
D 1049 N	1200 ... 1800	2590	18,5	1710,0	1050/130	0,81	0,17	0,038	180	D57.26/79
D 452 N	1200 ... 1800	710	10,8	583,2	450/130	0,77	0,48	0,0855	180	DFL54/78
D 452 K										DFL54/78

■ Not for new design

* At $V_{RRM} < 800$ V + 50 V

* Highest voltage on request

Diodes

up to 3000 V										
Type 	V_{RRM} V $V_{RSM} = V_{RRM} + 100$ V	I_{FRMSM} A	I_{FSM} kA 10 ms, $T_{vj\ max}$	J^2dt $A^2 \cdot s \cdot 10^3$ 10 ms $T_{vj\ max}$	I_{FAVM}/T_c $A/^\circ C$ 180° sinus	$V_{(T0)}$ V $T_{vj} = T_{vj\ max}$	r_T m Ω $T_{vj} = T_{vj\ max}$	R_{thJC} $^\circ C/W$ 180° el sin	$T_{vj\ max}$ $^\circ C$	outline / page
D 121 N	1200 ... 2000	360	2,60	33,8	120/130	0,72	1,90	0,324	180	DSW27/78
D 121 K	1200 ... 2000	330	2,40	28,8	120/130	0,72	1,90	0,434	180	DSW27/78
D 251 N	1200 ... 2000	400	5,30	140,5	250/130	0,80	0,85	0,151	180	DSW27/78 DFL36/78
D 251 K	1200 ... 2000	400	4,70	110,5	250/102	0,80	0,85	0,236	180	DSW27/78 DFL36/78
D 400 N	1600 ... 2200	710	9,80	480,2	400/130	0,70	0,62	0,095	180	DSW41/78
■ D 400 K	1600 ... 2200	710	9,80	480,2	400/130	0,70	0,62	0,095	180	DSW41/78
D 428 N	1200 ... 2000	840	6,00	180	430/139	0,81	0,54	0,069	180	D41.14/79
D 660 N	1200 ... 2200	1435	10,25	525	660/130	0,70	0,50	0,050	180	D41.14K/81
D 748 N	2000 ... 2800	1260	9,00	405	750/100	0,83	0,52	0,045	160	D50.14/79
D 1029 N	1800 ... 2600	2040	14,50	1051	1030/100	0,82	0,28	0,038	160	D57.26/79
D 1030 N	1800 ... 2600	2040	14,50	1051	1030/100	0,82	0,28	0,038	160	D57.26K/81
D 1709 N	2000 ... 2400	2700	18,00	1620	1700/90	0,83	0,20	0,0245	160	D75.26/80
D 2209 N	2000 ... 2800	4900	35,00	6125	2200/100	0,83	0,145	0,017	160	D75.26/80
D 2200 N	2000 ... 2800	4900	35,00	6125	2200/100	0,83	0,145	0,017	160	D75.26K/81
D 2650 N	2000 ... 2400	4710	33,50	5611	2650/100	0,82	0,148	0,0169	180	D75.26K/80
D 2659 N	2000 ... 2400	4710	33,50	5611	2650/100	0,82	0,148	0,0169	180	D75.26/80
D 4201 N	1600 ... 2200	10350	73,50	27000	4650/100	0,70	0,075	0,009	160	D120.35K/82
D 4709 N	2000 ... 2800	8400	60,00	18000	4700/100	0,83	0,07	0,008	160	D110.26/80

■ Not for new design

Diodes

up to 5000 V										
Type 	V_{RRM} V $V_{RSM} = V_{RRM} + 100$ V	I_{FRMSM} A	I_{FSM} kA 10 ms, $T_{vj\ max}$	$\int i^2 dt$ $A^2 \cdot s \cdot 10^3$ 10 ms $T_{vj\ max}$	I_{FAVM}/T_c $A/^\circ C$ 180° sinus	$V_{(TO)}$ V $T_{vj} = T_{vj\ max}$	r_T $m\Omega$ $T_{vj} = T_{vj\ max}$	R_{thJC} $^\circ C/W$ 180° el sin	$T_{vj\ max}$ $^\circ C$	outline / page
■ D 269 N	3200 ... 3600	550	4,0	80	270/100	0,86	1,540	0,098	150	D57.26/79
D 475 N	3200 ... 4000	745	10,9	594	475/100	0,765	0,612	0,085	160	DSW41.1/78
■ D 475 K	3200 ... 4000	745	10,9	594	475/100	0,765	0,612	0,085	160	DSW41.1/78
D 749 N	3600 ... 4800*	1540	11,0	605	750/100	0,85	0,650	0,039	160	D57.26/79
D 849 N	2800 ... 4000*	1790	12,8	819	850/100	0,84	0,485	0,038	160	D57.26/79
D 850 N	2800 ... 4000*	1790	12,8	819	850/100	0,84	0,485	0,038	160	D57.26K/81
■ D 1069 N	3600 ... 4400	2200	15,5	1201	1070/100	0,85	0,460	0,027	160	D75.26/80
D 1809 N	3200 ... 4800	3850	27,5	3781	1800/100	0,85	0,253	0,0169	160	D75.26/80
D 1800 N	3200 ... 4800	3850	27,5	3781	1800/100	0,85	0,253	0,0169	160	D75.26K/81
D 3501 N	3200 ... 4200	8300	56	15680	3700/100	0,76	0,128	0,009	160	D120.35K/82

up to 10000 V										
Type 	V_{RRM} V $V_{RSM} = V_{RRM} + 100$ V	I_{FRMSM} A	I_{FSM} kA 10 ms, $T_{vj\ max}$	$\int i^2 dt$ $A^2 \cdot s \cdot 10^3$ 10 ms $T_{vj\ max}$	I_{FAVM}/T_c $A/^\circ C$ 180° sinus	$V_{(TO)}$ V $T_{vj} = T_{vj\ max}$	r_T $m\Omega$ $T_{vj} = T_{vj\ max}$	R_{thJC} $^\circ C/W$ 180° el sin	$T_{vj\ max}$ $^\circ C$	outline / page
D 711 N	5800 ... 6800	1660	8,5	360	780/100	0,845	0,872	0,030	160	D58.26K/81
D 1481 N	5800 ... 6800	3400	20,0	2000	1600/100	0,880	0,41	0,015	160	D76.26K/81
D 3001 N	5800 ... 6800	6030	53,0	14040	2820/100	0,860	0,21	0,009	160	D120.35K/82
D 471 N	8000 ... 9000	1200	10,0	500	565/100	1,180	1,69	0,030	160	D58.26K/81
D 2601 N	8500 ... 9000	4850	50,0	12500	2600/85	1,000	0,40	0,008	160	D120.26K/82

■ Not for new design

Fast Diodes

up to 1000 V											
Type	V_{RRM} V $V_{RSM} = V_{RRM} + 100$ V	I_{FRMSM} A	I_{FSM} kA 10 ms $T_{vj\ max}$	$\int i^2 dt$ $A^2 \cdot s \cdot 10^3$ 10 ms $T_{vj} = T_{vj\ max}$	I_{FAVM}/T_c $A/^\circ C$ 180° sinus	$V_{(TO)}$ V $T_{vj} = T_{vj\ max}$	r_T mΩ $T_{vj} = T_{vj\ max}$	I_{RM} A $T_{vj\ max}$ $i_F = I_{FAVM}$, $di_F/dt = 50$ A/μs	R_{thJC} °C/W 180° el sin	$T_{vj\ max}$ °C	outline / page
D 138 S	900 ... 1000	230	1,60	12,80	138/85	1,32	2,20	47 ³⁾	0,140	125	D41.14/81
■ D 358 S	600 ... 1000	730	5,20	135,20	358/100	1,05	0,80	70	0,079	150	D41.14/81
D 648 S	800 ... 1000	1400	10,10	510,05	648/100	1,05	0,43	82	0,044	150	D50.14/81
D 649 S	800 ... 1000	1400	10,10	510,05	650/96	1,05	0,43	82	0,048	150	D57.26/81

up to 1400 V											
Type	V_{RRM} V $V_{RSM} = V_{RRM} + 100$ V	I_{FRMSM} A	I_{FSM} kA 10 ms $T_{vj\ max}$	$\int i^2 dt$ $A^2 \cdot s \cdot 10^3$ 10 ms $T_{vj} = T_{vj\ max}$	I_{FAVM}/T_c $A/^\circ C$ 180° sinus	$V_{(TO)}$ V $T_{vj} = T_{vj\ max}$	r_T mΩ $T_{vj} = T_{vj\ max}$	I_{RM} A $T_{vj\ max}$ $i_F = I_{FAVM}$, $di_F/dt = 50$ A/μs	R_{thJC} °C/W 180° el sin	$T_{vj\ max}$ °C	outline / page
D 188 S	1000 ... 1400	290	1,90	18,05	185/100	1,00	1,80	80	0,150	150	D41.14/79
■ D 211 S	1000 ... 1400	400	4,30	92,45	211/100	1,00	1,00	100	0,155	150	DSW27/78
■ D 211 U	1000 ... 1400	400	3,90	76,05	150/100	1,00	1,00	100	0,245	150	DSW27/78
D 238 S	1200	455	3,20	51,20	238/85	1,45	1,10	45	0,080	125	D41.14/79
D 368 S	1000 ... 1400	730	5,20	135,20	368/100	1,00	0,80	102	0,080	150	D41.14/79
D 658 S	1000 ... 1400	1400	10,10	510,05	658/100	1,00	0,45	122	0,044	150	D50.14/79
D 659 S	1000 ... 1400	1400	10,10	510,05	660/95	1,00	0,45	122	0,048	150	D57.26/79

²⁾ $i_{FM} = 150$ A, $-di_F/dt = 200$ A/μs
³⁾ $i_{FM} = 225$ A, $-di_F/dt = 100$ A/μs
⁴⁾ $i_{FM} = 500$ A, $-di_F/dt = 200$ A/μs

⁵⁾ $i_{FM} = 500$ A, $-di_F/dt = 250$ A/μs
⁶⁾ $i_{FM} = 760$ A, $-di_F/dt = 500$ A/μs
⁷⁾ $i_{FM} = 1000$ A, $-di_F/dt = 20$ A/μs

⁸⁾ $i_{FM} = 1600$ A, $-di_F/dt = 600$ A/μs
⁹⁾ $i_{FM} = 1000$ A, $-di_F/dt = 250$ A/μs
 ■ Not for new design

Fast Diodes

up to 2600 V											
Type	V_{RRM} V $V_{RSM} = V_{RRM} + 100$ V	I_{FRMSM} A	I_{FSM} kA 10 ms $T_{vj\ max}$	$\int i^2 dt$ $A^2 \cdot 10^3$ 10 ms $T_{vj} = T_{vj\ max}$	I_{FAVM}/T_c $A/^\circ C$ 180° sinus	$V_{(TO)}$ V $T_{vj} = T_{vj\ max}$	r_T $m\Omega$ $T_{vj} = T_{vj\ max}$	I_{RM} A $T_{vj\ max}$ $i_F = I_{FAVM}$, $di_F/dt = 50$ A/ μ s	R_{thJC} $^\circ C/W$ 180° el sin	$T_{vj\ max}$ $^\circ C$	outline / page
D 170 S	2500	400	3,70	68,45	170/85	1,10	1,400	340 ⁴⁾	0,190	140	DSW27.1/78
D 170 U	2500	330	3,15	49,60	170/64	1,10	1,500	340 ⁴⁾	0,260	140	DSW27.1/78
D 228 S	2200, 2500	450	3,20	51,20	228/85	1,18	1,800	280	0,080	125	D41.14/79
D 348 S	1600 ... 2000	645	4,60	105,80	348/100	1,00	0,900	160	0,080	150	D41.14/79
D 438 S	1600 ... 2000	740	5,30	140,50	440/100	1,14	0,725	770 ⁵⁾	0,059	150	D41.14/79
D 440 S	1600 ... 2000	740	5,30	140,50	440/100	1,14	0,725	770 ⁵⁾	0,059	150	D57.26K/81
■ D 509 S	2400 ... 2600	1050	7,50	281,25	509/100	1,00	0,800	205	0,049	150	D57.26/79
D 675 S	2000, 2500	1200	8,50	361,00	675/85	1,25	0,500	860 ⁸⁾	0,039	140	D57.26K/81
D 689 S	2000 ... 2600	1600	11,50	661,25	690/100	1,00	0,500	230	0,039	150	D57.26/79
D 690 S											D57.26K/81
D 1169 S	2000, 2500	3360	24,00	2880,00	1170/85	1,16	0,210	580 ⁹⁾	0,0194	125	D75.26/80
D 1170 S	2000, 2500	3360	24,00	2880,00	1170/85	1,16	0,210	580 ⁹⁾	0,0194	125	D75.26K/81
D 1408 S	2000, 2500	3360	24,00	2880,00	1410/85	1,16	0,210	580 ⁹⁾	0,0150	125	D75.14/80

up to 6000 V											
Type	V_{RRM} V $V_{RSM} = V_{RRM} + 100$ V	I_{FRMSM} A	I_{FSM} kA 10 ms $T_{vj\ max}$	$\int i^2 dt$ $A^2 \cdot 10^3$ 10 ms $T_{vj} = T_{vj\ max}$	I_{FAVM}/T_c $A/^\circ C$ 180° sinus	$V_{(TO)}$ V $T_{vj} = T_{vj\ max}$	r_T $m\Omega$ $T_{vj} = T_{vj\ max}$	I_{RM} A $T_{vj\ max}$ $i_F = I_{FAVM}$, $di_F/dt = 50$ A/ μ s	R_{thJC} $^\circ C/W$ 180° el sin	$T_{vj\ max}$ $^\circ C$	outline / page
D 56 S	4000, 4500	160	1,35	9,1	56/85	1,64	8,00	230 ²⁾	0,2600	125	DSW27.2/78
D 56 U	4000, 4500	140	1,20	7,2	56/73	1,64	8,00	230 ²⁾	0,3400	125	DSW27.2/78
■ D271 S	4500	600	4,30	100,0	270/85	2,35	1,50	400 ⁹⁾	0,0430	125	D58.26K/81
D 281 S	6000	610	5,00	125,0	280/85	2,15	2,38	550 ⁹⁾	0,0375	140	D58.26K/81
D 291 S	3500 ... 4500	700	4,50	100,0	290/85	1,90	1,76	500 ⁹⁾	0,0430	125	D58.26K/81
D 371 S	4500	800	6,00	180,0	330/85	2,00	1,49	500 ⁹⁾	0,0375	125	D58.26K/81
D 721 S	3500 ... 4500	1700	15,00	1130,0	720/85	1,70	0,69	600 ⁹⁾	0,0192	125	D76.26K/81
D 901 S	3500 ... 4500	1920	21,50	2300,0	900/85	1,80	0,68	550 ⁹⁾	0,0134	125	D100.26K/82
D 1461 S	3500 ... 4500	2700	32,00	5120,0	1460/85	1,43	0,38	840 ⁹⁾	0,0134	140	D100.26K/82

²⁾ $i_{FM} = 150$ A, - $di_F/dt = 200$ A/ μ s⁵⁾ $i_{FM} = 500$ A, - $di_F/dt = 250$ A/ μ s⁸⁾ $i_{FM} = 1600$ A, - $di_F/dt = 600$ A/ μ s³⁾ $i_{FM} = 225$ A, - $di_F/dt = 100$ A/ μ s⁶⁾ $i_{FM} = 760$ A, - $di_F/dt = 500$ A/ μ s⁹⁾ $i_{FM} = 1000$ A, - $di_F/dt = 250$ A/ μ s⁴⁾ $i_{FM} = 500$ A, - $di_F/dt = 200$ A/ μ s⁷⁾ $i_{FM} = 1000$ A, - $di_F/dt = 20$ A/ μ s

■ Not for new design

Avalanche Diodes

Type 	V_{RRM} V $V_{RSM} = V_{RRM} + 100$ V	I_{FRMSM} A	I_{FSM} kA 10 ms, $T_{vj\ max}$	$\int i^2 dt$ $A^2 \cdot s \cdot 10^3$ 10 ms, $T_{vj\ max}$	I_{FAVM}/T_c $A/^\circ C$ 180° sinus	$V_{(TO)}$ V $T_{vj} = T_{vj\ max}$	r_T $m\Omega$ $T_{vj} = T_{vj\ max}$	$V_{(BR)}$ A min.	R_{thJC} $^\circ C/W$ 180° el sin	$T_{vj\ max}$ $^\circ C$	outline / page
D 126 A 45	4500	315	2,30	26,45	126/100 200/35	0,86	3,2	4800	0,257	160	DSW27.2/78
D 126 B 45	4500	300	2,10	22,00	126/80 190/9	0,86	3,2	4800	0,337	160	DSW27.2 /78
DD 126 A 45 K-B9*	4500	220	2,30	26,45	128/100	0,86	3,2	4800	0,060	160	DP30.1 /71

* Non isolated module

Welding Diodes

up to 600 V											
Type 	V_{RRM} V $V_{RSM} = V_{RRM} + 100$ V (50 V) ¹⁾	I_{FRMSM} A	I_{FSM} kA 10 ms, $T_{vj\ max}$	$\int i^2 dt$ $A^2 \cdot s \cdot 10^3$ 10 ms $T_{vj\ max}$	I_{FAVM}/T_c $A/^\circ C$ 180° sinus	$V_{(TO)}$ V $T_{vj} = T_{vj\ max}$	r_T $m\Omega$ $T_{vj} = T_{vj\ max}$	R_{thJC} $^\circ C/W$ 180° el sin	$T_{vj\ max}$ $^\circ C$	outline / page	
25 DN 06	600	1800	12,75	813	1145/155	0,7	0,188	0,0174	180	25DN06/83	
46 DN 06	600	8000	52,00	13500	5100/118	0,7	0,047	0,00935	180	46DN06/83	
56 DN 06	600	10050	70,00	24500	6400/116	0,7	0,040	0,0062	180	56DN06/83	
65 DN 06	600	13300	95,00	45000	8470/98	0,7	0,027	0,0047	180	65DN06/83	

Insulated Cells

Type	V_M V	V_{RMS} V_{DC}	CTI - Value	Iso-Class	$T_c(max)$ $^\circ C$	R_{thCK} $^\circ C/W$	$R_{thC-C (typ)}$ $^\circ C/W$	at clamp. force $V_W = 4$ l/min	F_{max} kN	weight g	outline / page
ISO 57/26	6400	2520	250	III a	150	0,010	0,088	at 12kN	30	260	157.26/83
ISO 72/8	2250	700	250	III a	150	0,005	0,028	at 20kN	45	130	172.8/83
ISO 75/14	3500	1250	250	III a	150	0,005	0,0435	at 20kN	45	245	175.14/83
ISO 75/26	5900	2250	250	III a	150	0,005	0,048	at 20kN	45	460	175.26/83
ISO 65/35	10600	4180	250	III a	150	0,010	0,136	at 12kN	30	350	165.35/83
ISO 120/35	11700	4400	250	III a	150	0,002	0,0275	at 30kN	70	1650	1120.35/83
ISO 120/59	11700	4400	250	III a	150	0,002	0,029 ¹⁾	at 30kN	70	2500	1120.59/83

* On request

Insulating disc with water cooling

Insulating material: Al N

¹⁾ Water cooling with $V_W = 4$ l/min

Possible Combinations of Presspacks and Heatsinks

for air cooling
for water cooling

applicable up to V_{RRM}	BE/KK = Elements per Heatsink																
7000 V	1	K0.05.8F	K0.05.8F	K0.05.8F	K0.05.8F			K0.05.8F									
	1							KE01	KE01	KE01	KE01	KE01	KE01	KE01	KE01	KE01	KE01
	2							KE02	KE02	KE02	KE02	KE02	KE02	KE02	KE02	KE02	KE02
6000 V	1	K0.05.7F	K0.05.7F	K0.05.7F	K0.05.7F			K0.05.7F	K0.048.7F	K0.048.7F				K0.048.7F			
2600 V	1	K0.05F	K0.05F	K0.05F	K0.05F			K0.05F	K0.048F	K0.048F				K0.048F			
	2	K0.08F K0.92S	K0.08F K0.92S	K0.08F K0.92S	K0.08F K0.92S			K0.08F K0.92S									
	3	K0.11F	K0.11F	K0.11F	K0.11F			K0.11F									
	2	K0.024W	K0.024W	K0.024W	K0.024W	K0.024W	K0.024W	K0.024W									
	2, 4, 6							K53 K63	K53 K63	K53 K63	K53 K63	K53 K63	K53 K63	K53 K63	K53 K63	K53 K63	K53 K63
2900 V	2	KA30	KA30														
2200 V	1	KK32	KK32														
	2	KK34	KK34														
	1	K0.12F K0.36S	K0.12F K0.36S					K0.12F K0.36S									
	2	K0.17F K0.22F	K0.17F K0.22F					K0.17F K0.22F									
	2	K0.65S	K0.65S					K0.65S									
	2, 4, 6	KA20;KC20;KD20	KA20;KC20;KD20	KA20;KC20;KD20	KA20;KC20;KD20	KA20;KC20;KD20	KA20;KC20;KD20	KA20;KC20;KD20									
Outline		D41.14	D50.14	D57.26	D60.8	D60.14	D72.8	D75.26	D100.26	D110.26	D120.35						
		T41.14	T50.14	T57.26		T60.14		T75.26	T100.26	T110.26	T120.35	T120.26	T110.35	T120.26	T150.35		

K 1.1 - M 12

G = 0,635 kg

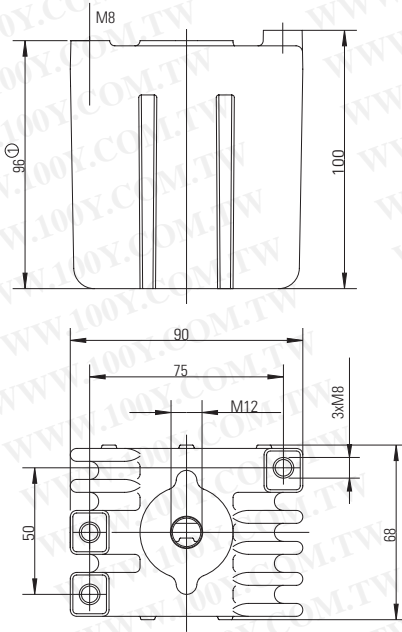

K 0.55 - FB 54 - A

G = 1,760 kg

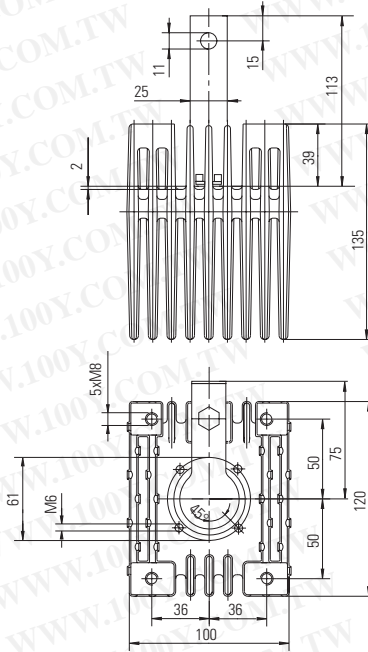

K0.55 - M 12
K0.55 - M 24 x 1,5

G = 1,760 kg
G = 1,760 kg

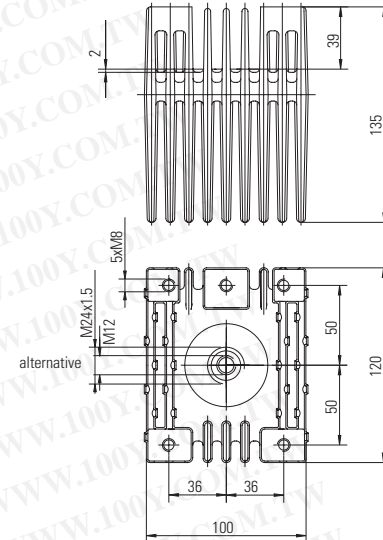

KM 10

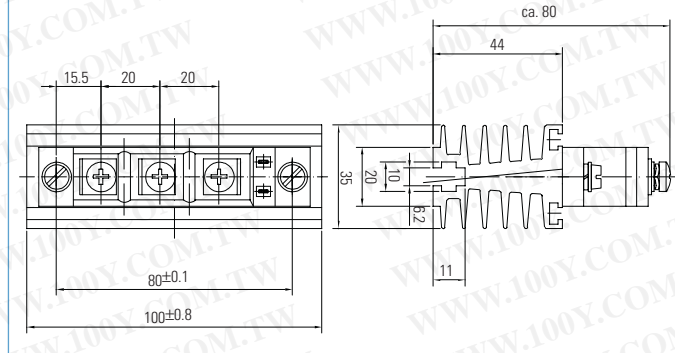
KM 11
KM 14
KM 17
KM 18

G = 2,1 kg
G = 3,1 kg
G = 5,3 kg
G = 8,8 kg

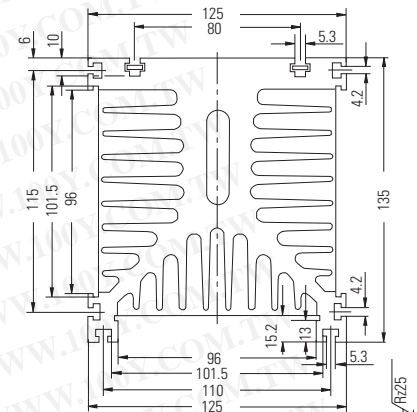

KM 11 H = 120 mm
KM 14 H = 180 mm
KM 17 H = 300 mm
KM 18 H = 500 mm

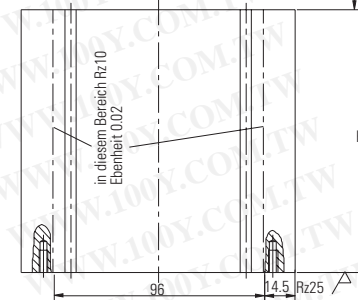

KA 20.X-V

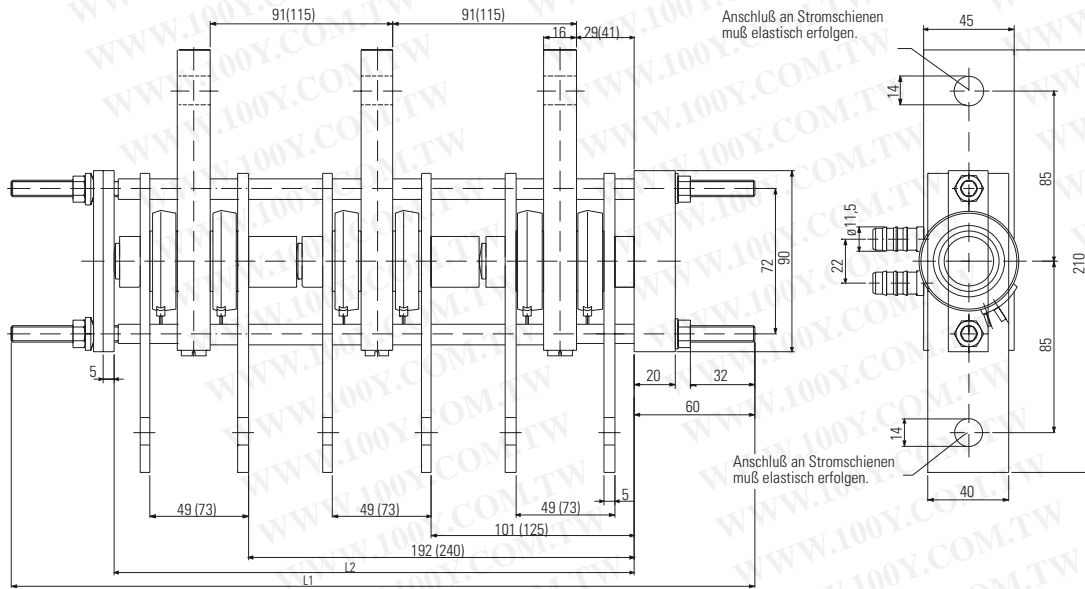

(...) für Bauelemente s=26

Anzahl Thy./Di.	Typ	L1	L2
6 (s=14mm)	-KA20.6...	370	259
4 (s=14mm)	-KA20.4-	280	168
2 (s=14mm)	-KA20.2-	190	77
6 (s=26mm)	-KA20.62-	445	331
4 (s=26mm)	-KA20.42-	325	216
2 (s=26mm)	-KA20.22-	210	101

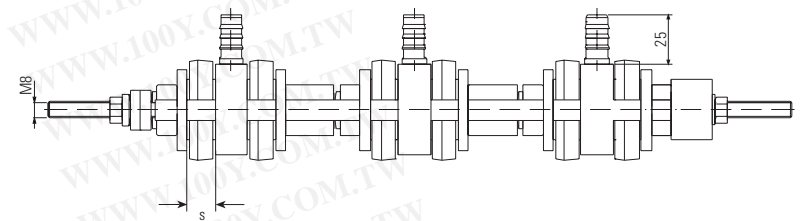

KC 20-XE

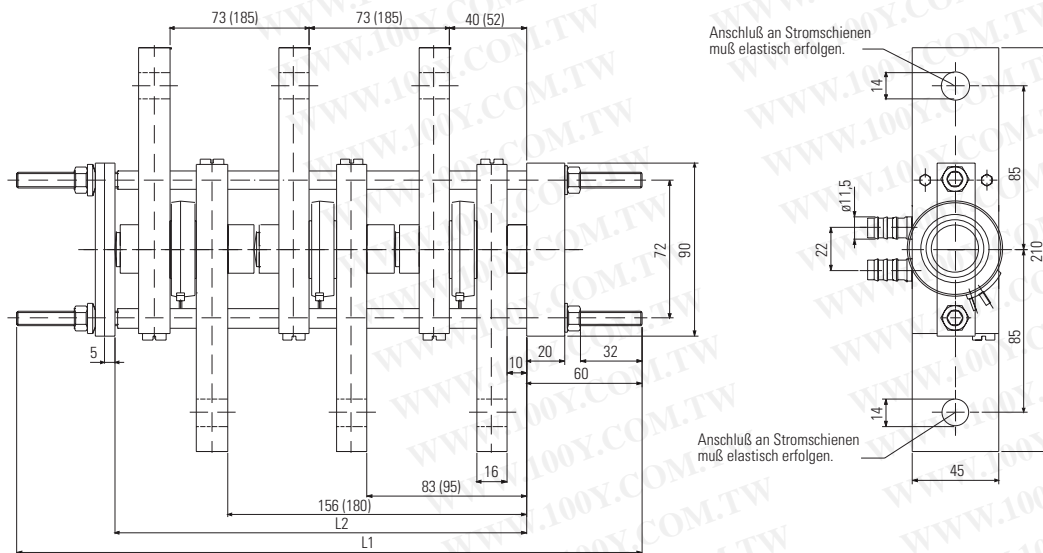

(...) für Bauelemente s=26

Anzahl Thy./Di.	Typ	L1	L2
3 (s=14mm)	-KC20-3E	325	215
2 (s=14mm)	-KC20-2E	250	142
1 (s=14mm)	-KC20-1E	175	69
3 (s=26mm)	-KC20-3E	260	251
2 (s=26mm)	-KC20-2E	275	166
1 (s=26mm)	-KC20-1E	190	81

Zellenlage bei KC20.x-E

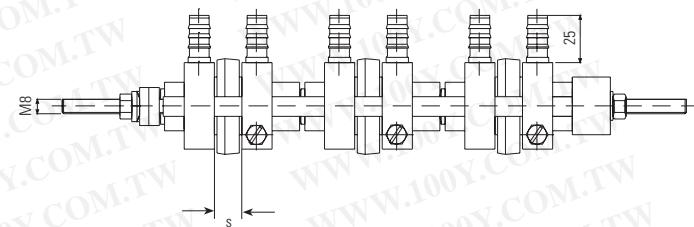
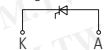

KD 20.X-V

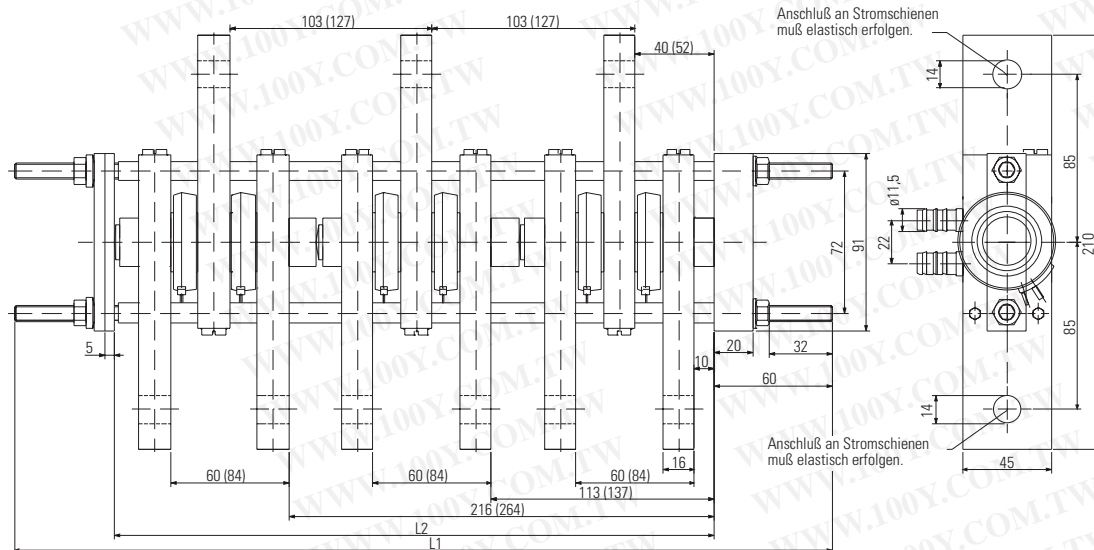

[...] für Bauelemente s=26

Anzahl Thy./Di.	Typ	L1	L2
6 (s=14mm)	-KD20.6...	415	305
4 (s=14mm)	-KD20.4-	310	202
2 (s=14mm)	-KD20.2-	205	99
6 (s=26mm)	-KD20.62-	490	377
4 (s=26mm)	-KD20.42-	360	250
2 (s=26mm)	-KD20.22-	230	123

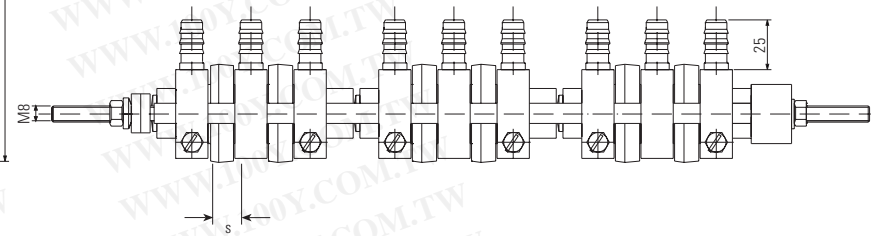

K 0.024 W

G = 3 kg

for W1C-circuits

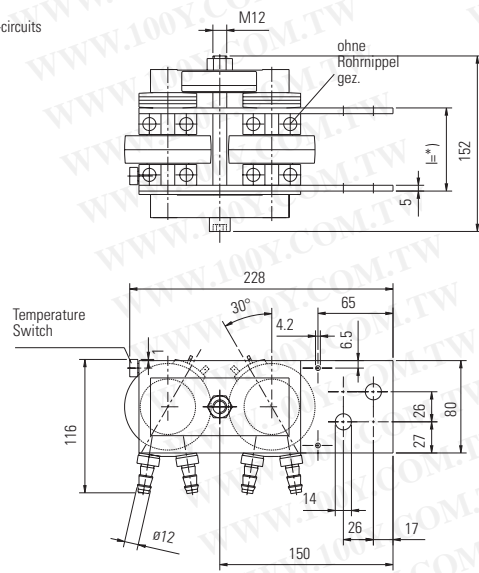

*) Bauelementhöhe 14 mm: l=60mm
Bauelementhöhe 26 mm: l=72mm

K 0.024 W

G = 3 kg

for B- and M-circuits

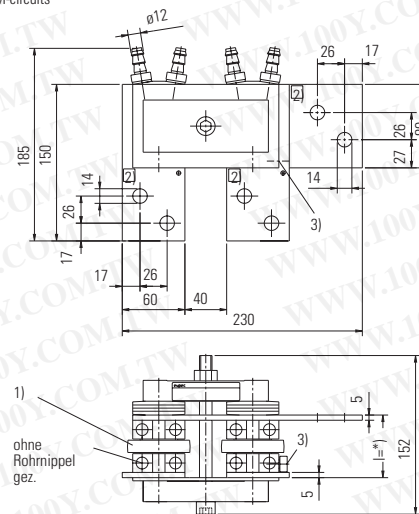

*) Bauelementhöhe 14 mm: l=60mm
Bauelementhöhe 26 mm: l=72mm

K 53 V

G = 17 kg

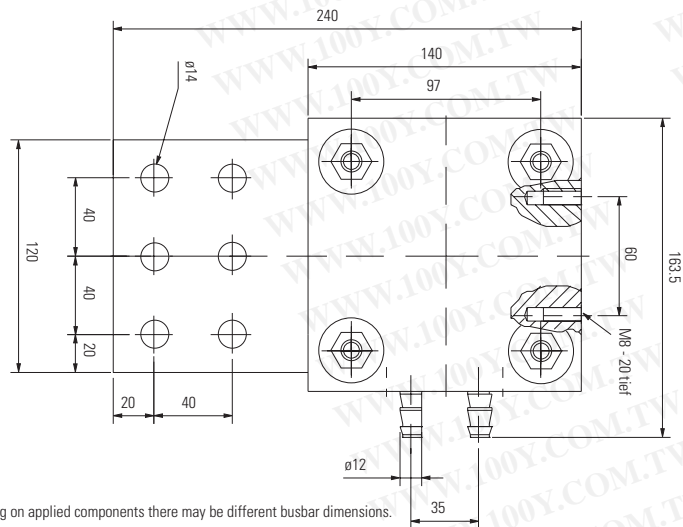
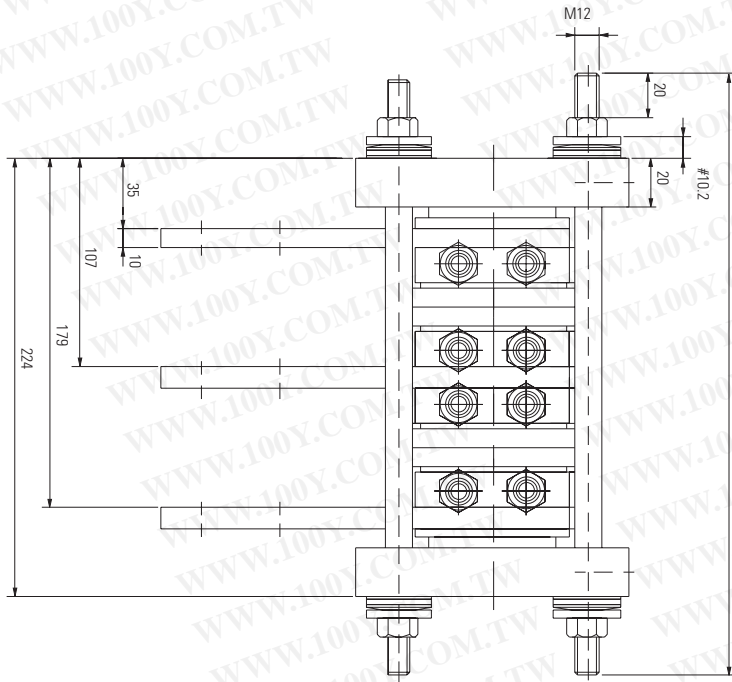

Example: Depending on applied components there may be different busbar dimensions.

K 63 V

G = 30 kg

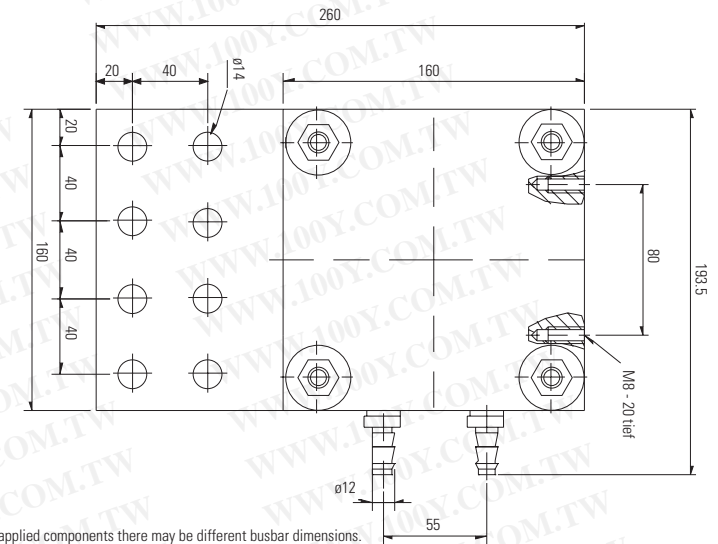
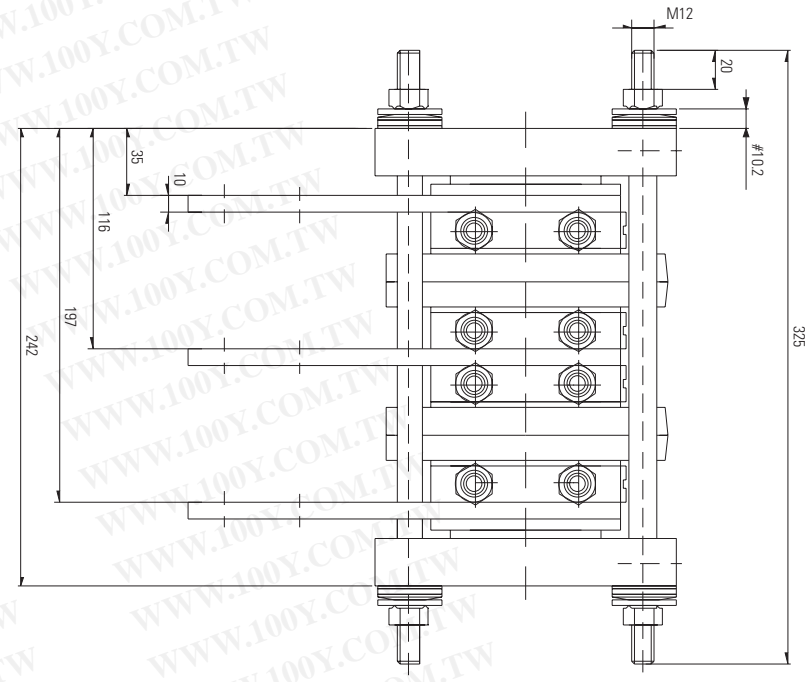

Example: Depending on applied components there may be different busbar dimensions.

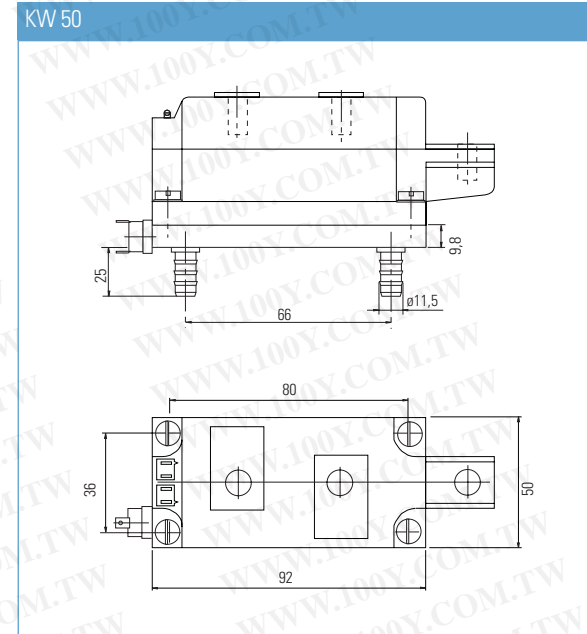
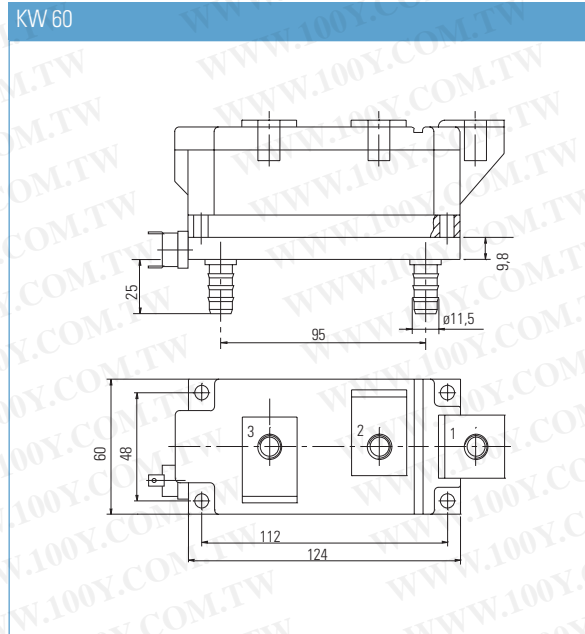

K 0.05F G = 9 kg

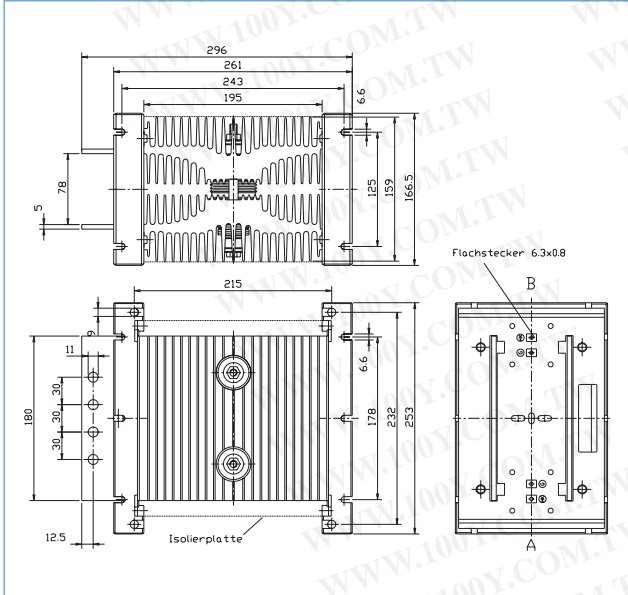

K 0.12F G = 2,5 kg

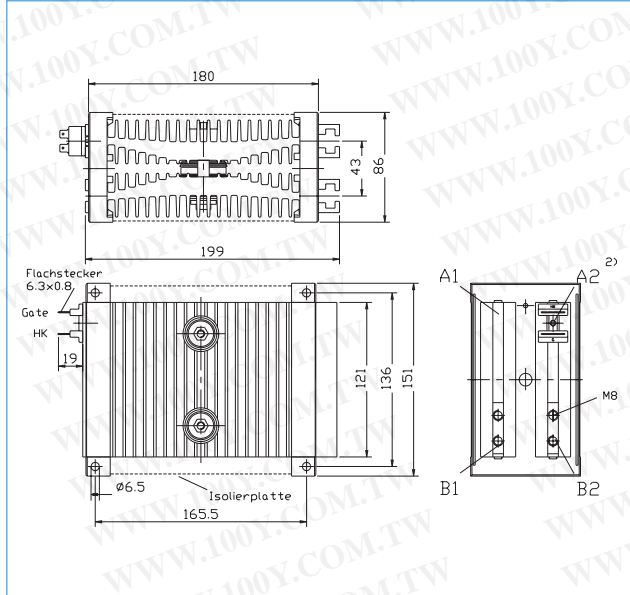

KK 32 G = 1 kg

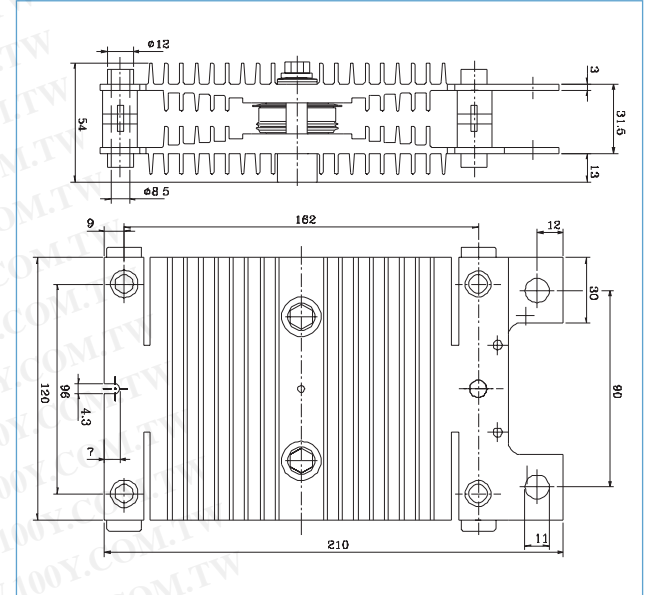

K 0.08 F/K 0.08.7 F/K 0.08.8 F G = 9 kg

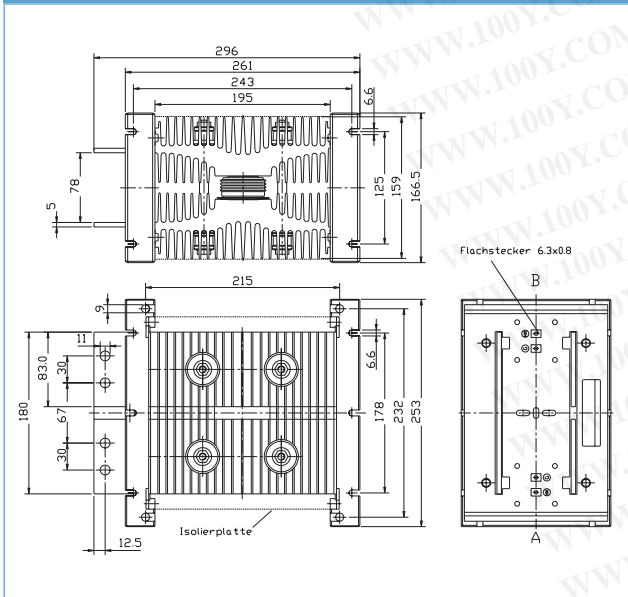

K 0.22 F G = 3 kg

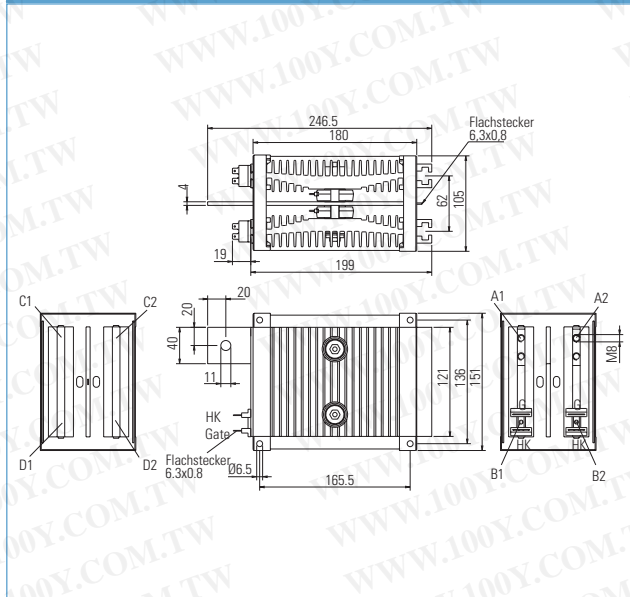

KK 34 G = 1,3 kg

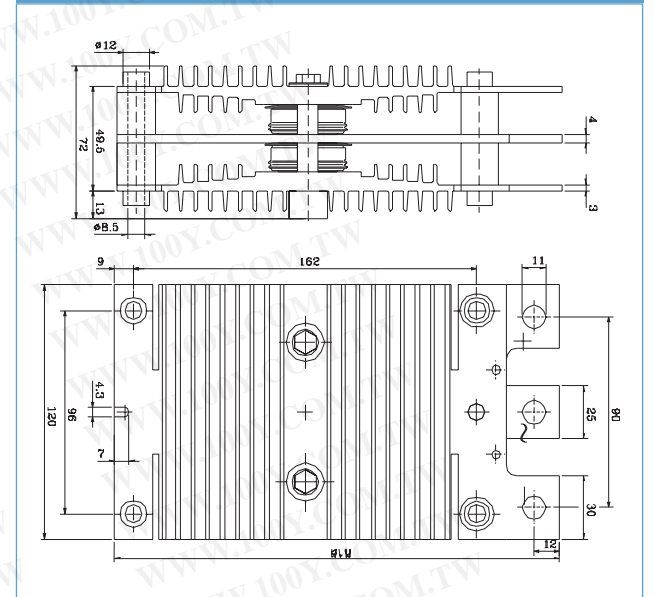

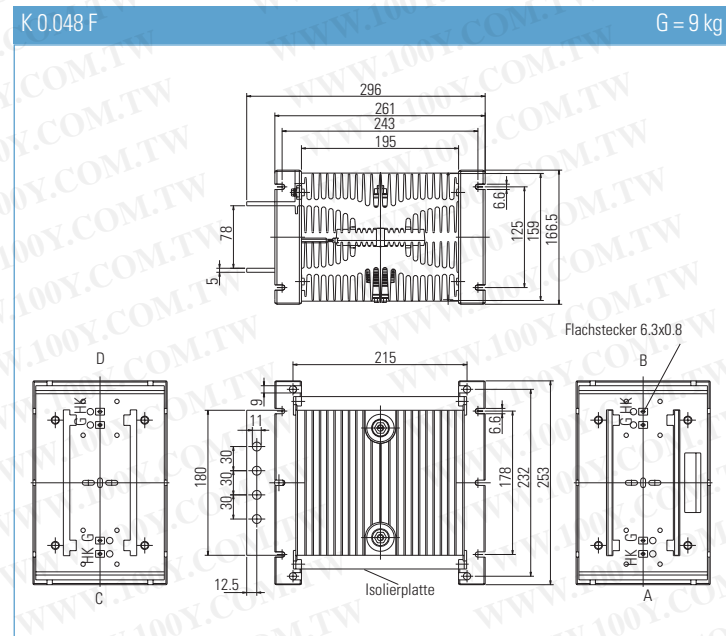
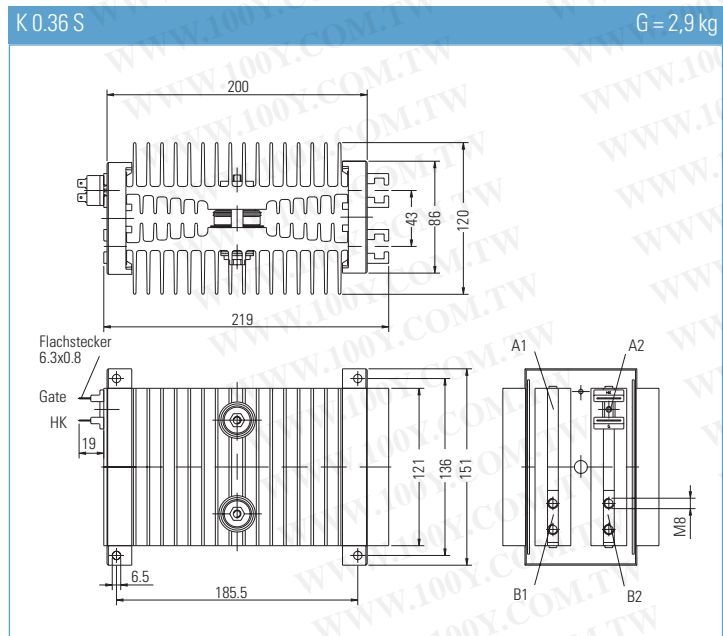
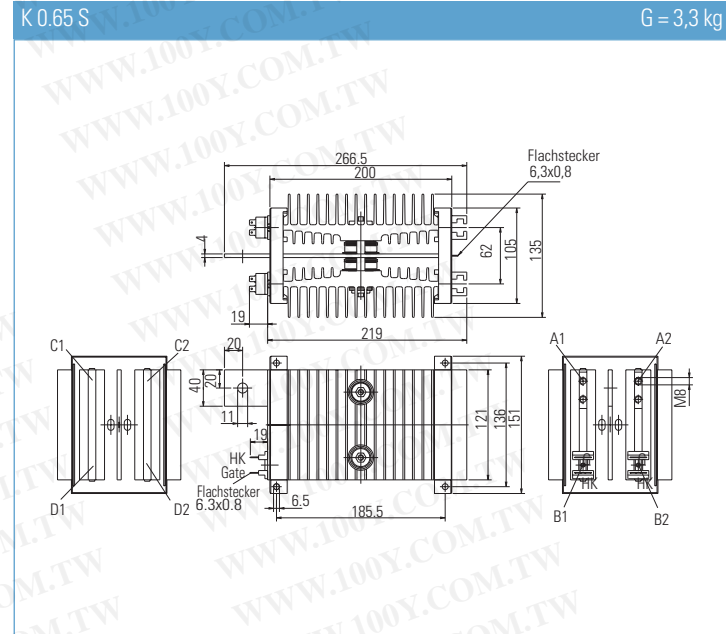
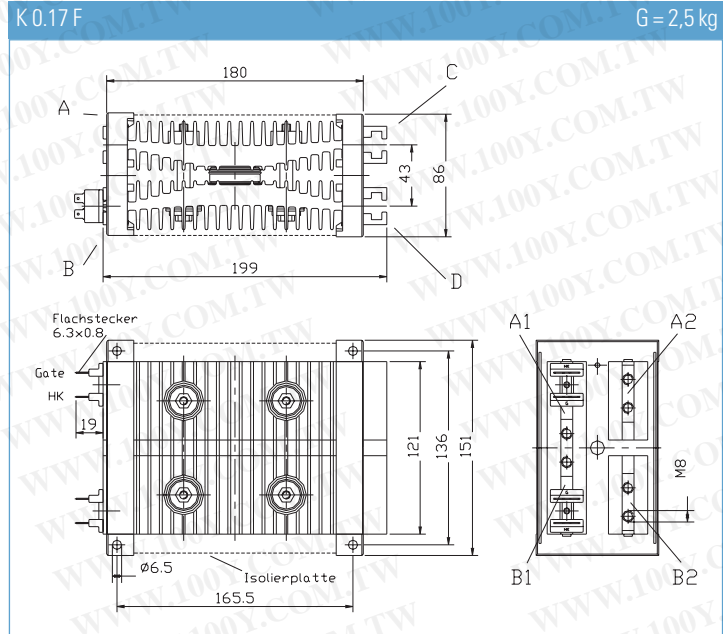

KE 01

G = 20 kg

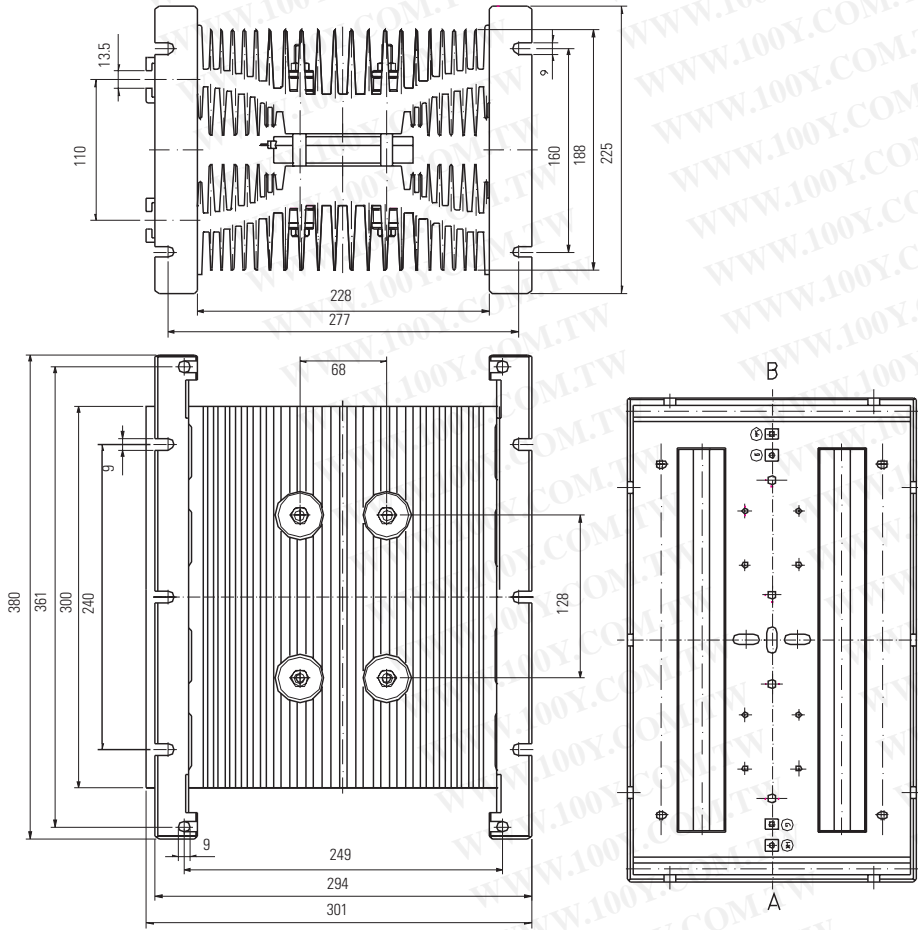

KE 02

G = 21 kg

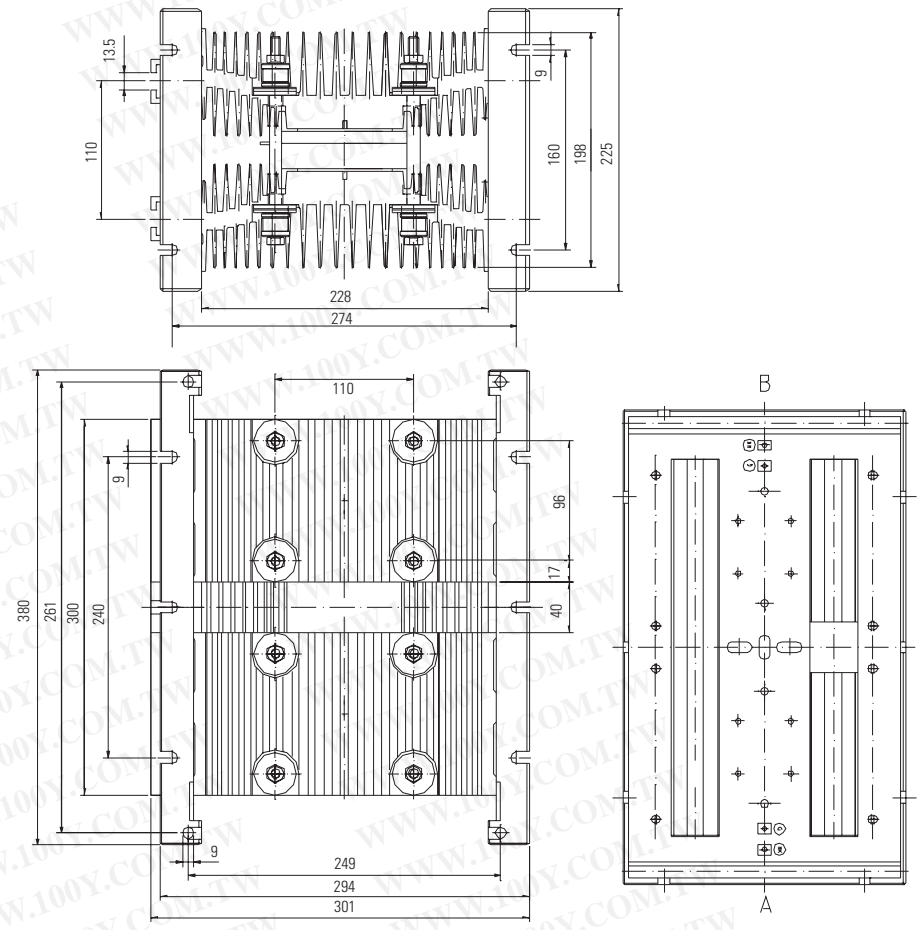

IH1

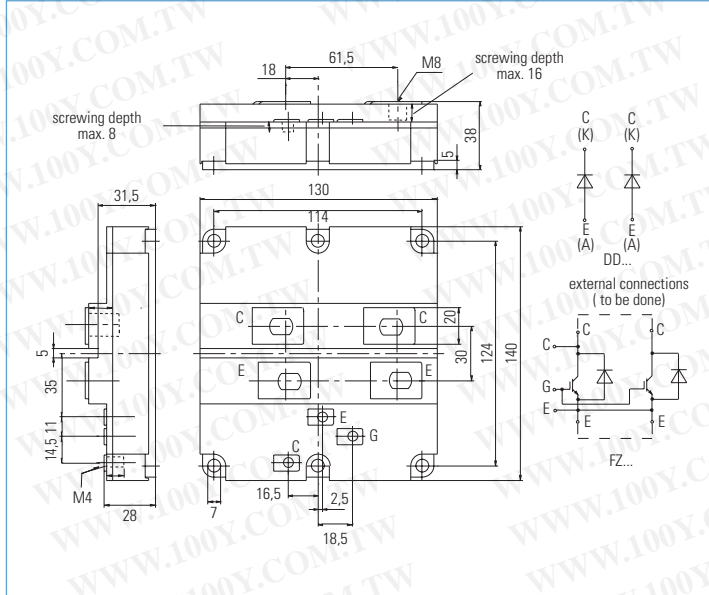

IH2

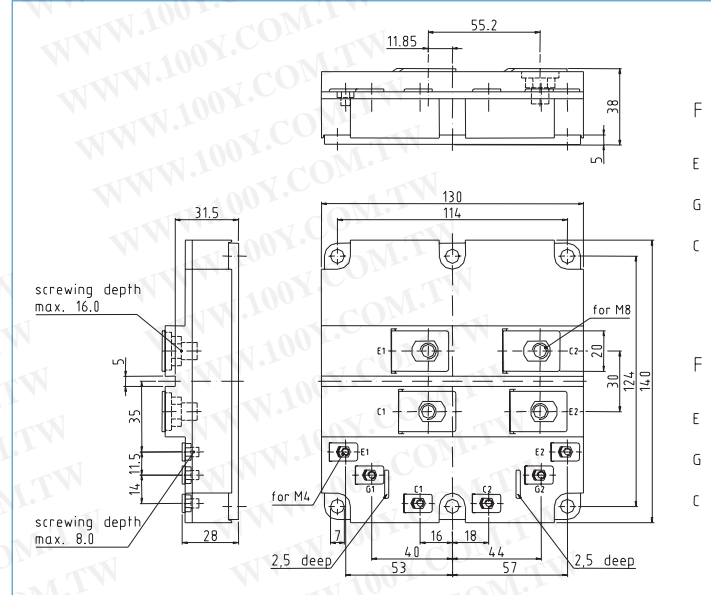

IH4

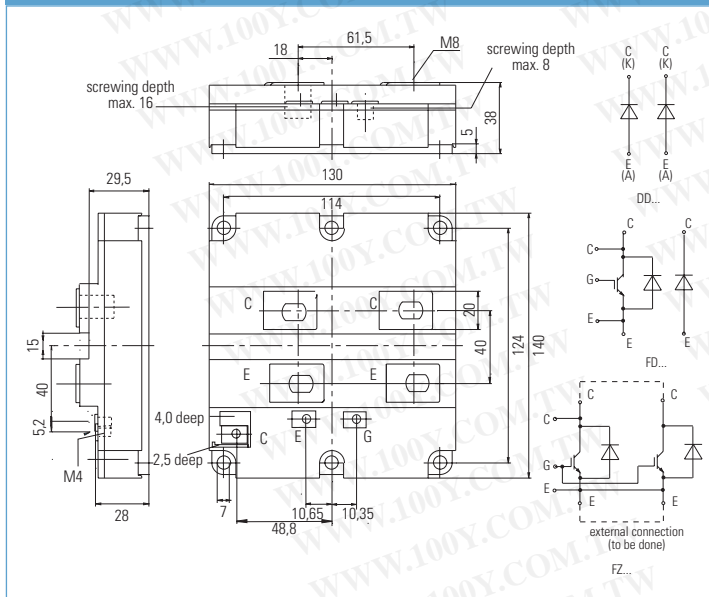

IH5

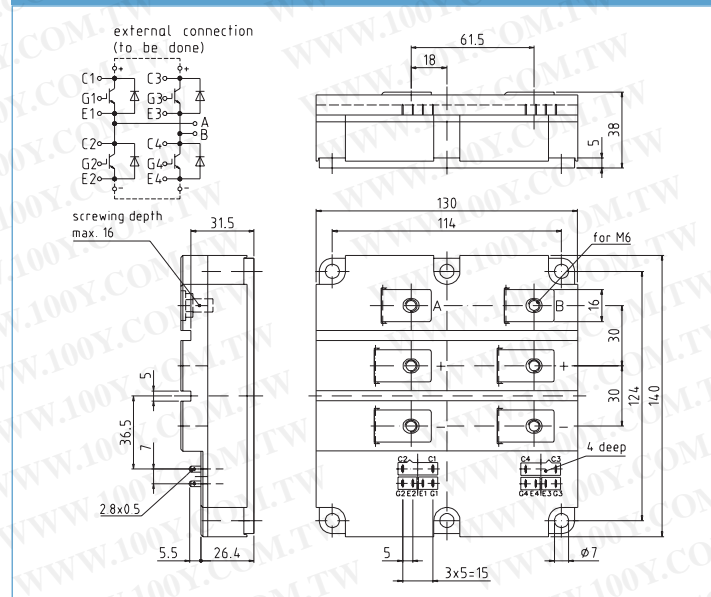

IH10

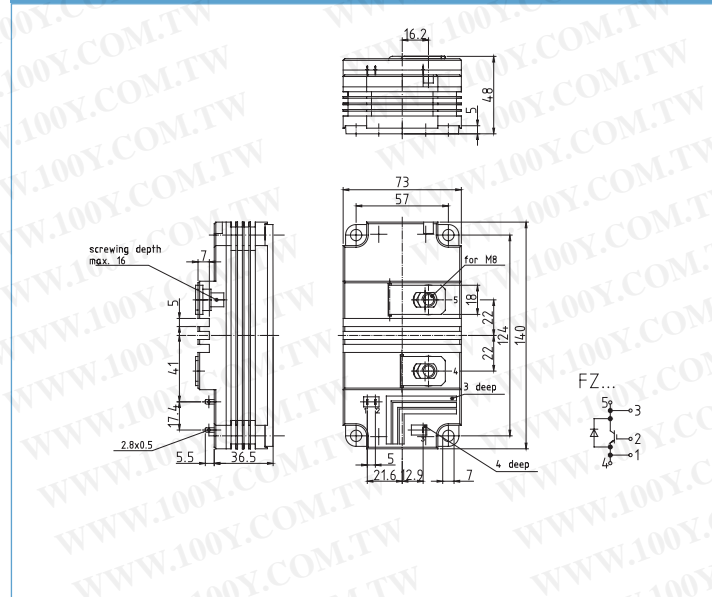

IH11

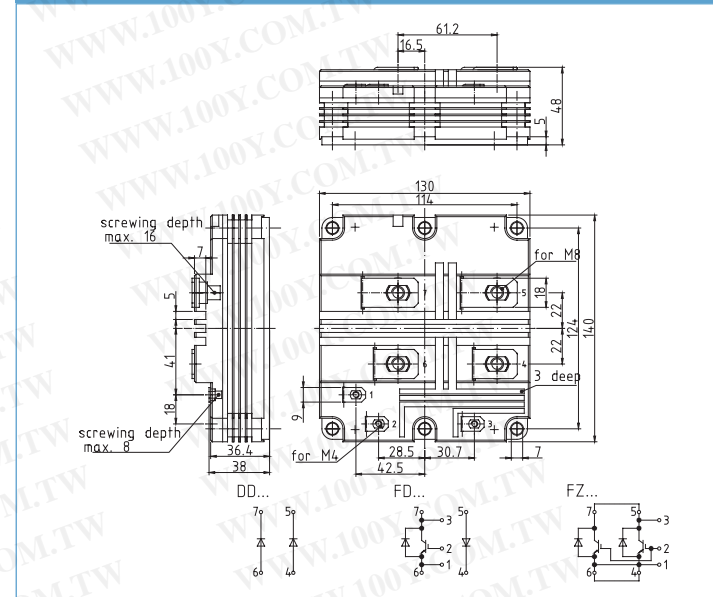

IH12

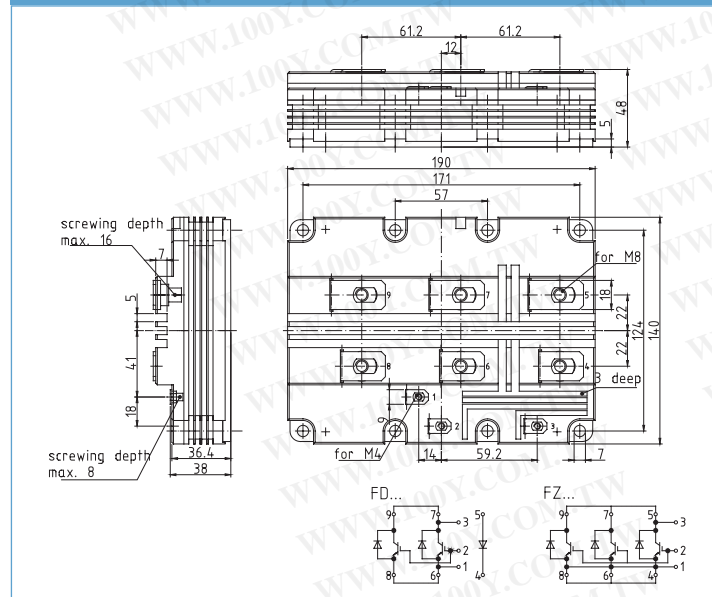

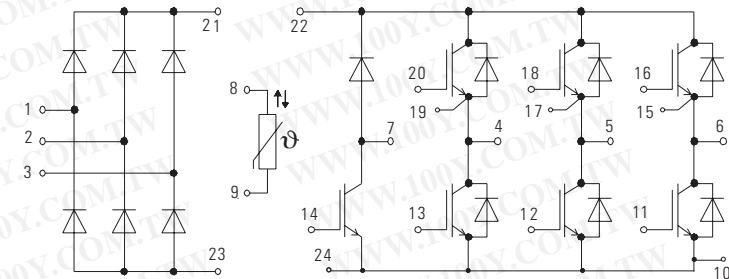
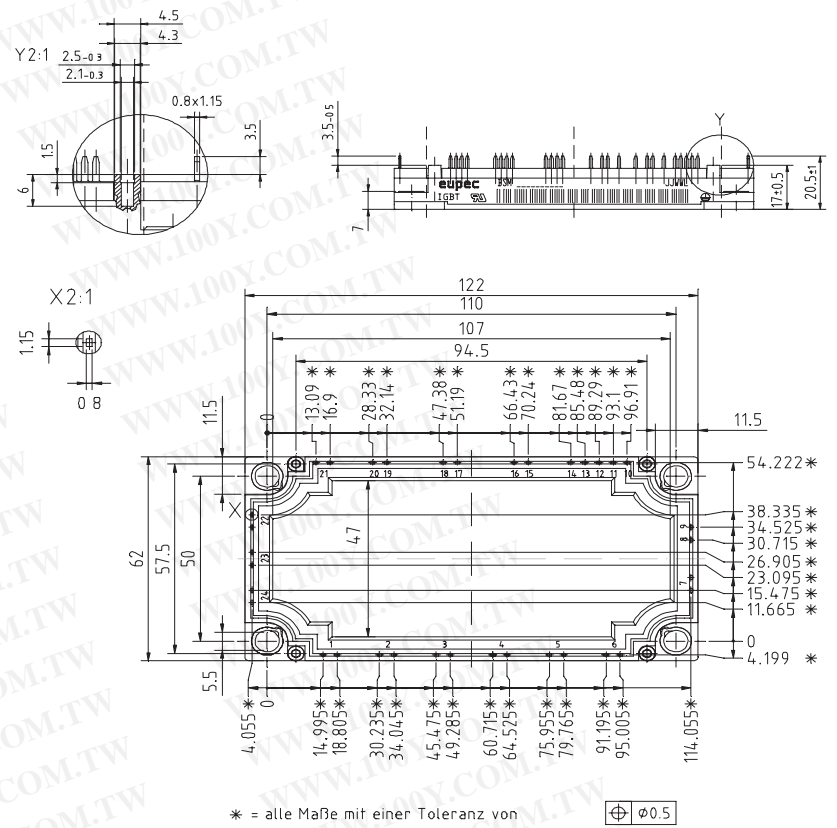
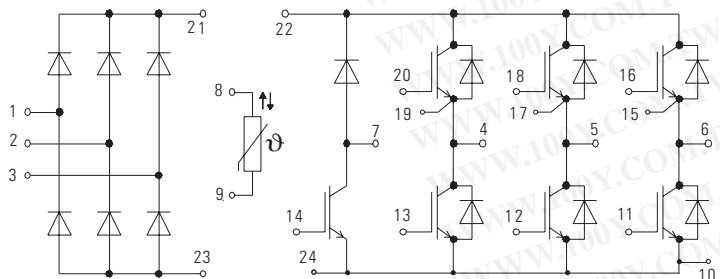
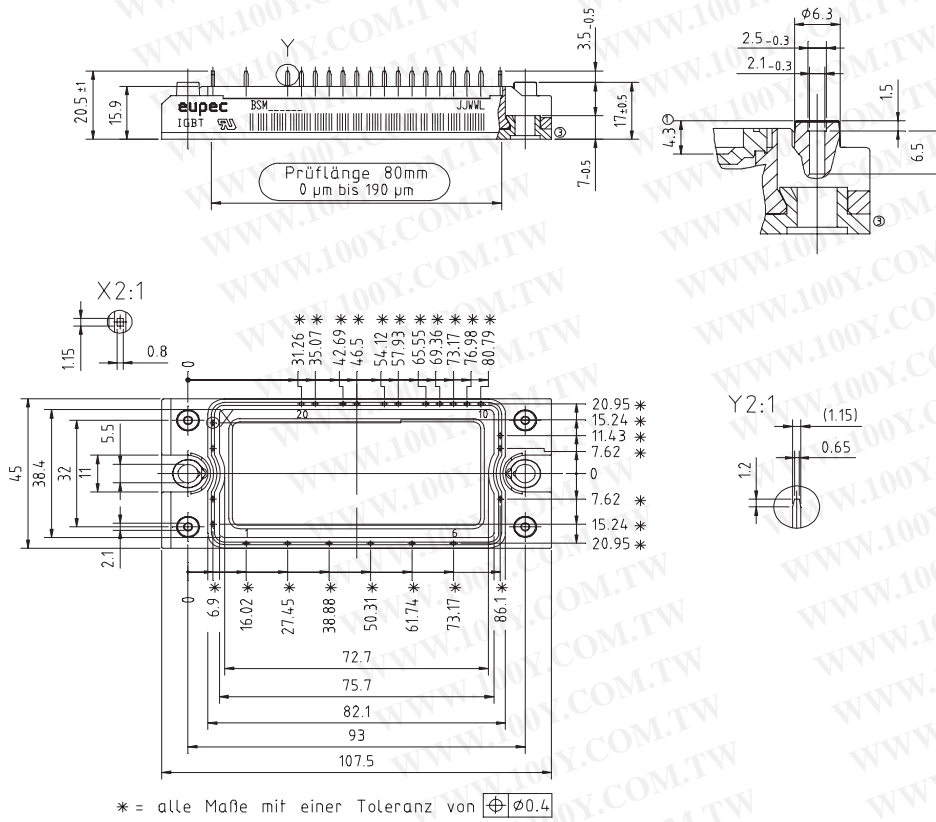

EconoPACK+

IS14

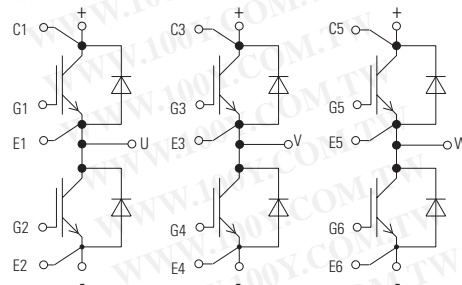
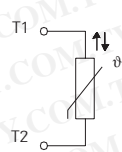
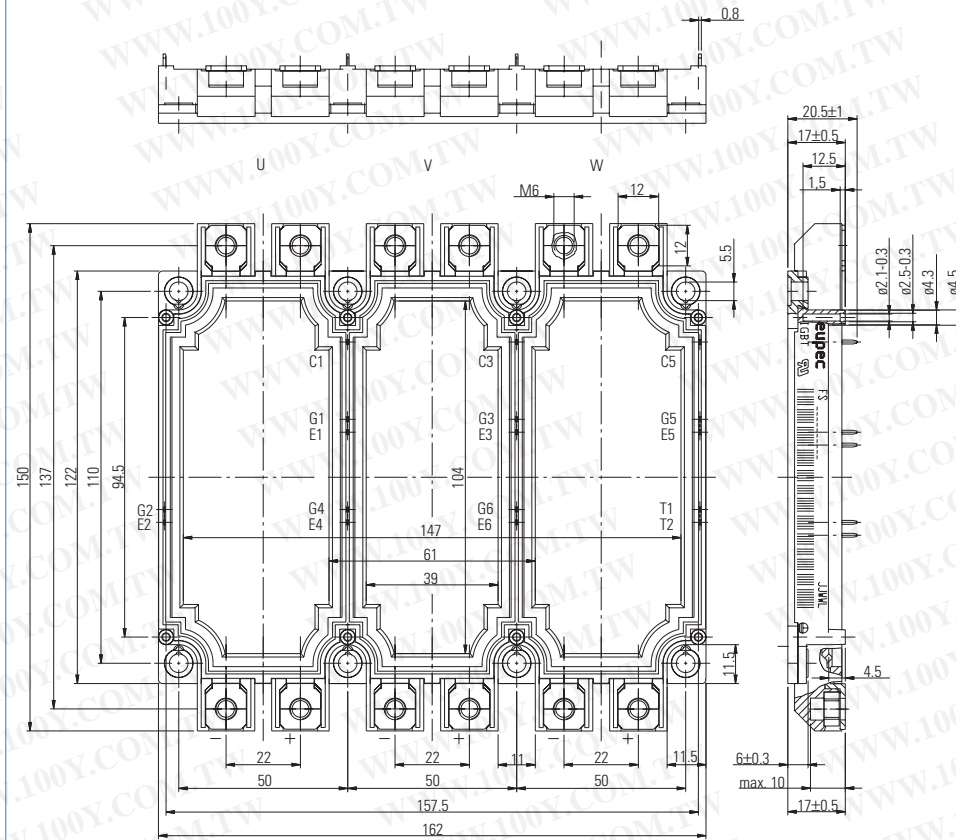

EasyPIM1

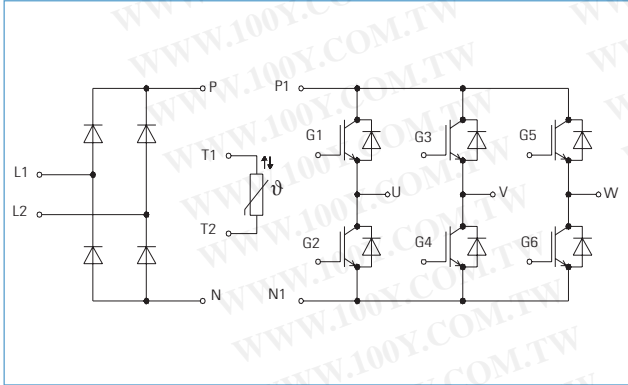

EasyPIM2

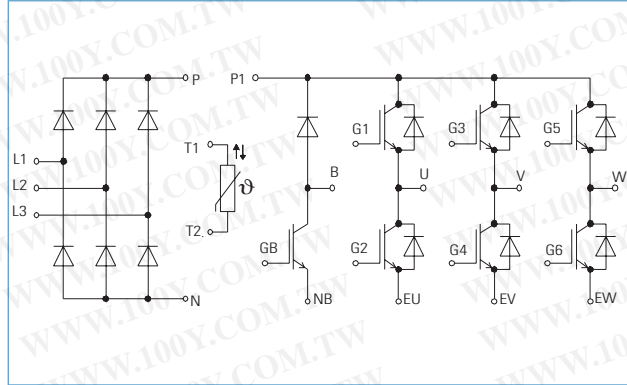

EasyPIM2 Single Phase

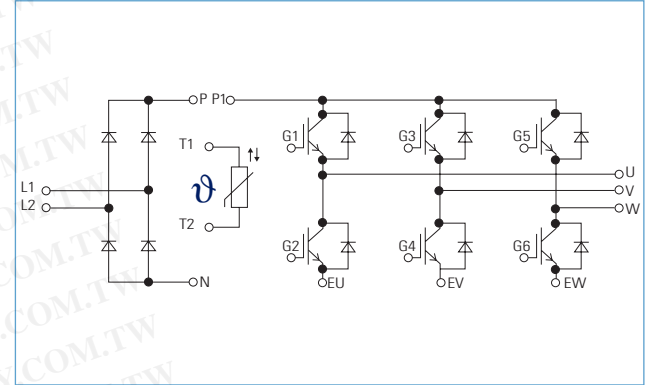

EasyPIM1

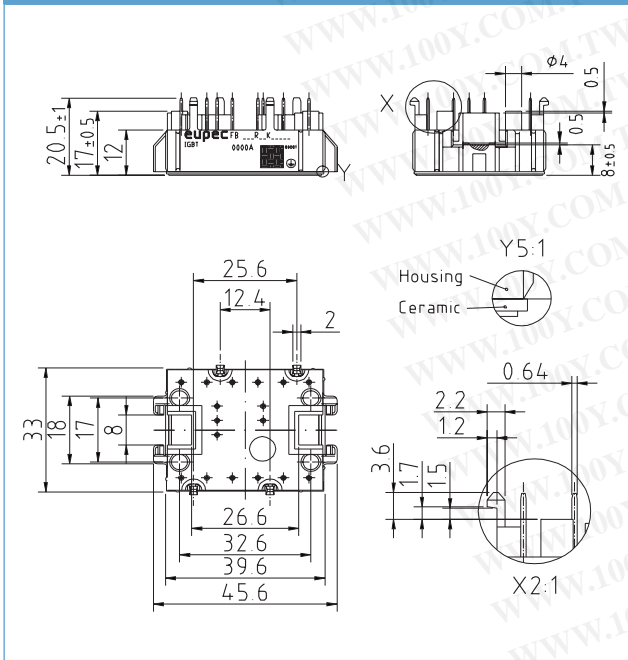

IS15

EasyPIM2

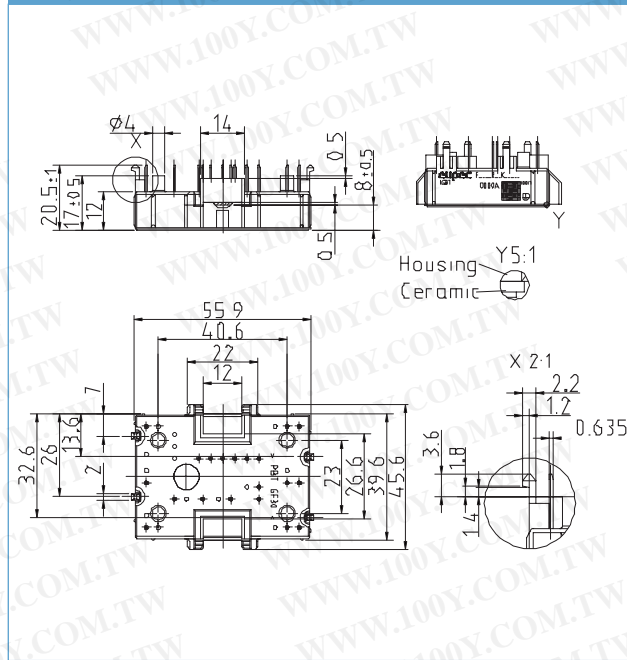

IS16

EasyPIM2 Single Phase

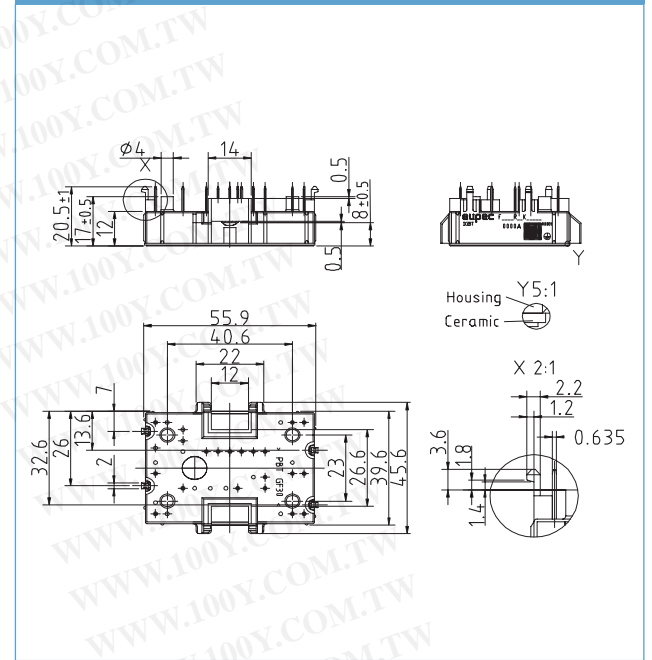

IS17

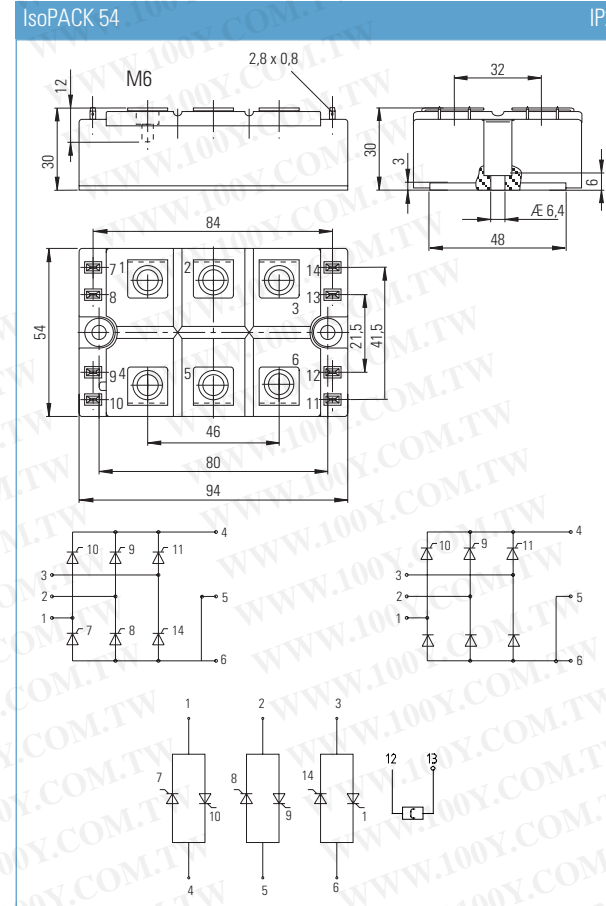
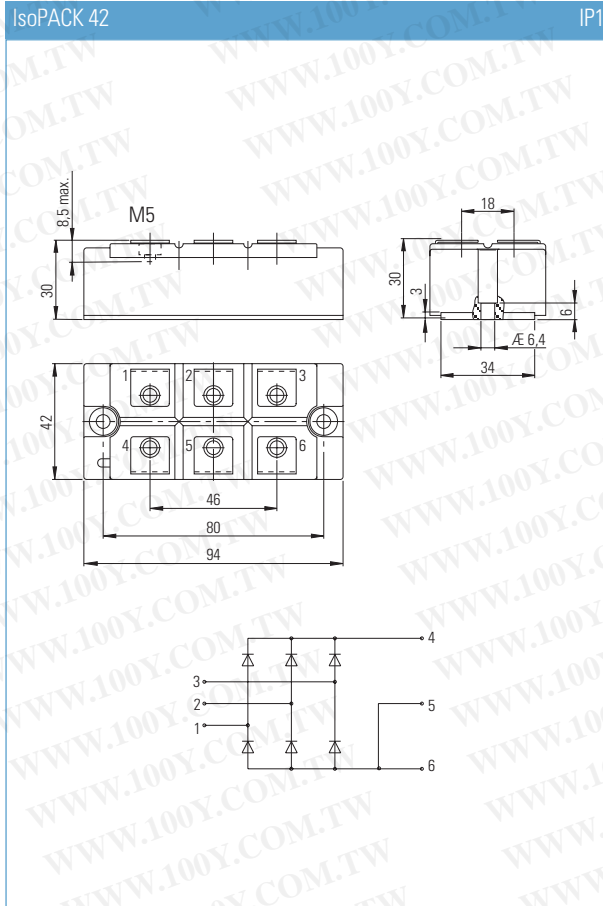

EconoBRIDGE Rectifier 2

EC1

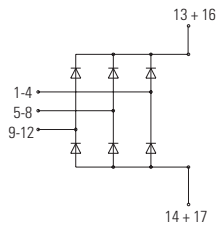
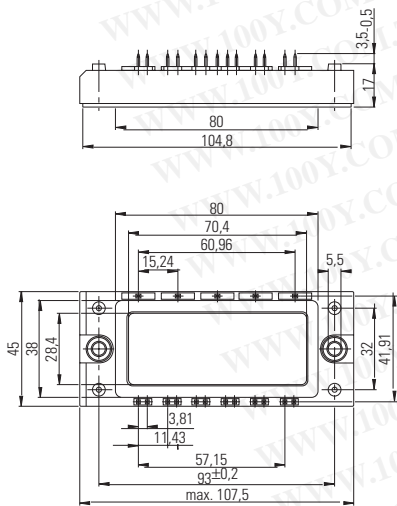

EconoBRIDGE Rectifier 2

EC2

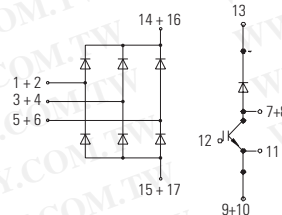
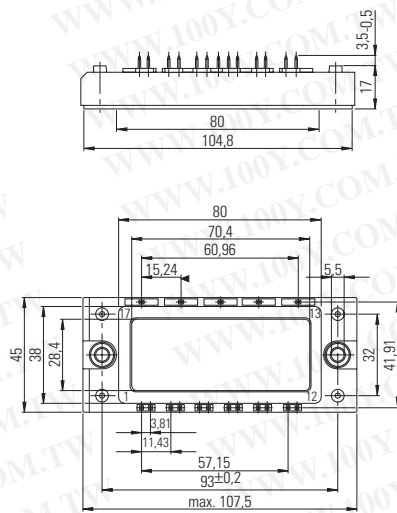

EconoBRIDGE Rectifier 2

EC3

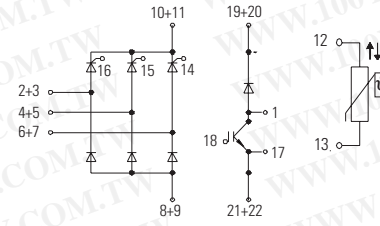
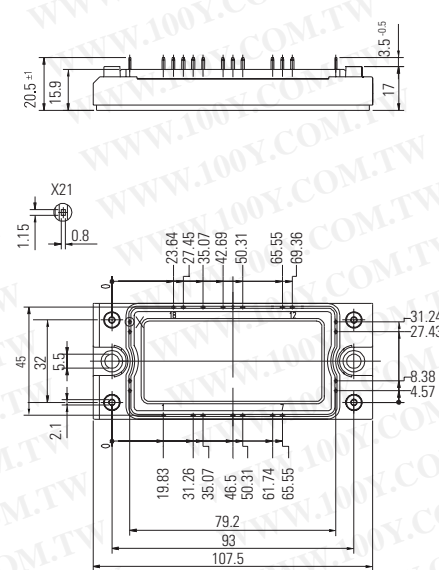

EconoBRIDGE Rectifier 2

EC 4

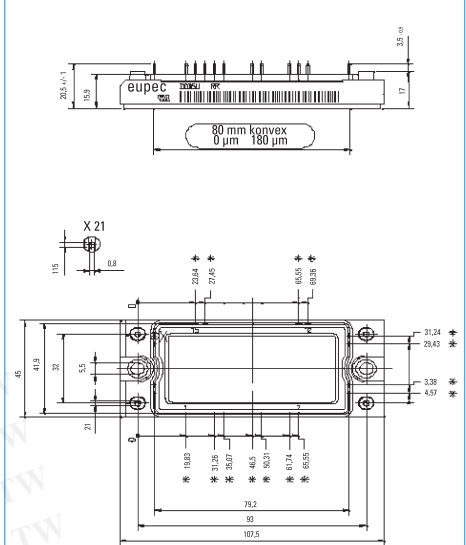

** all dimensions have a tolerance of ± 0.4

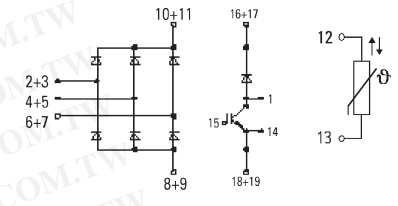

TP50.1

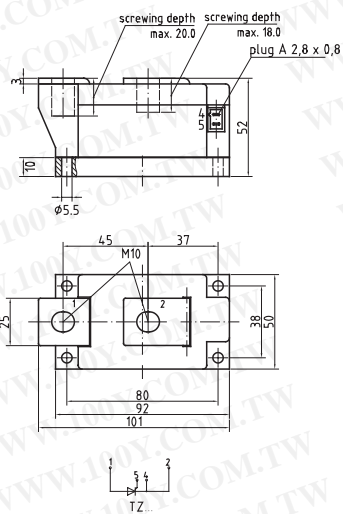

TP70

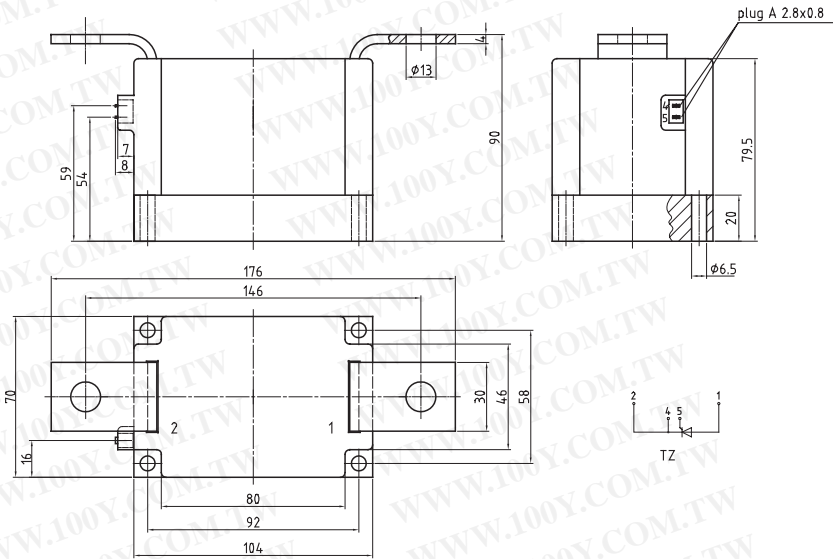

DP20

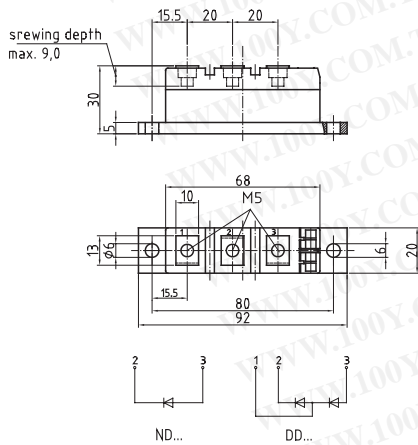

DP25

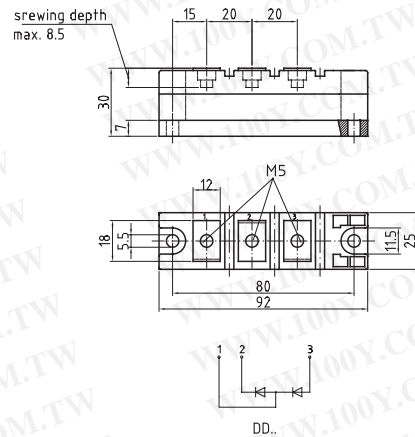

DP30

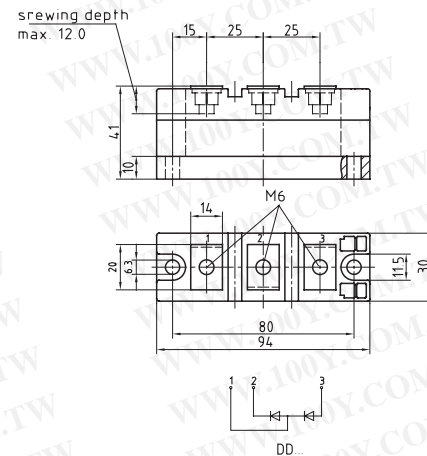

DP30.1

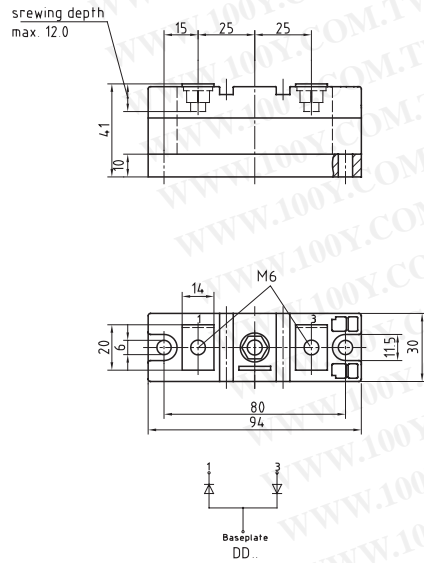

DP34

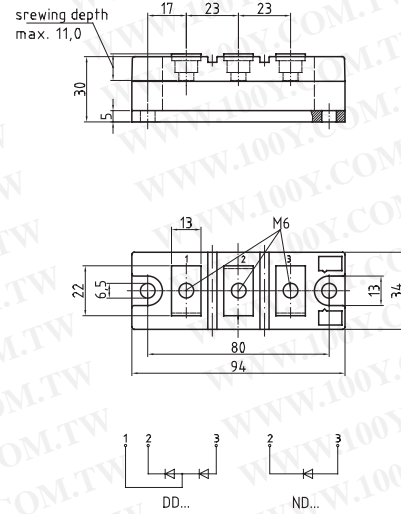

DP50

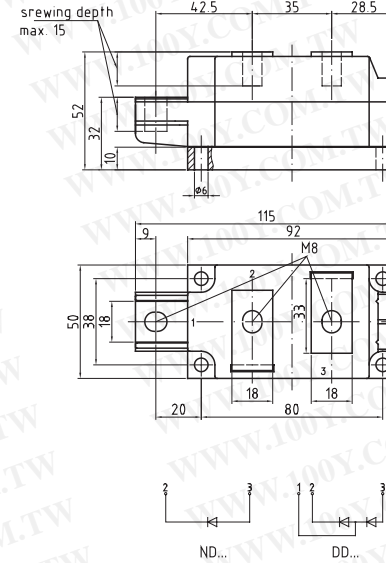

DP60

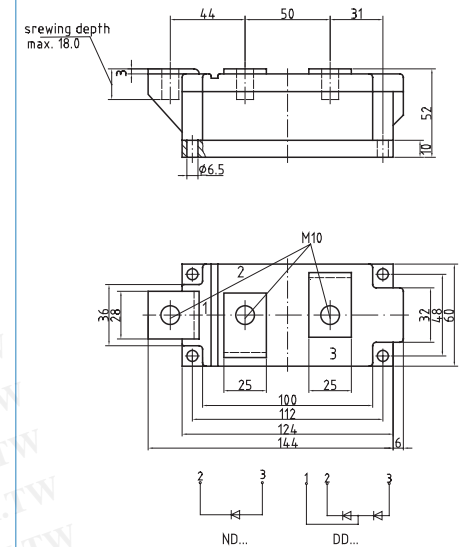

DP50ND

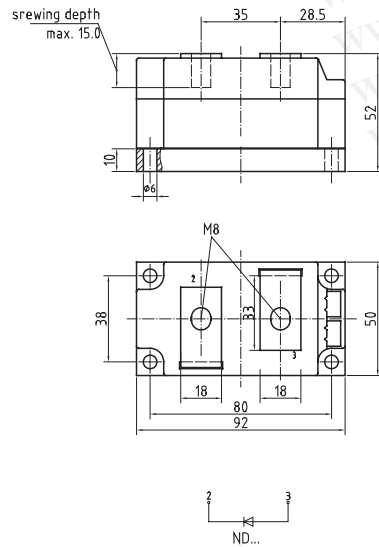

DP50.1

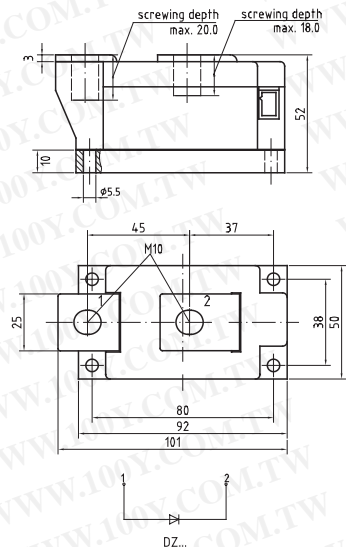

DP70

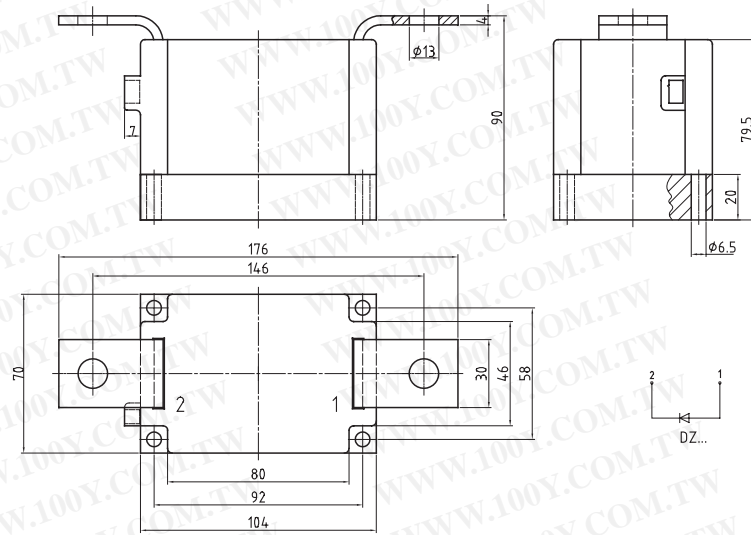

TSW27

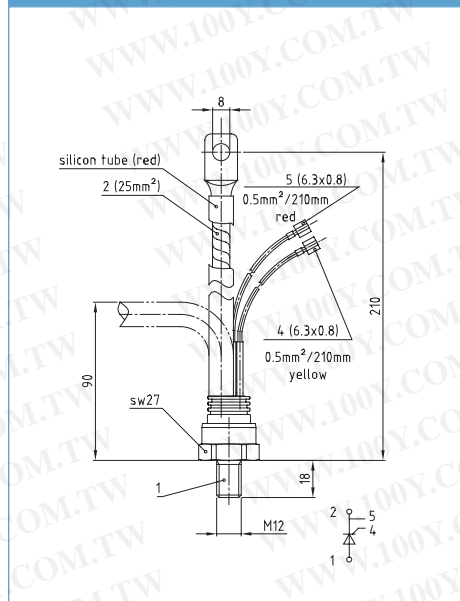

TFL36

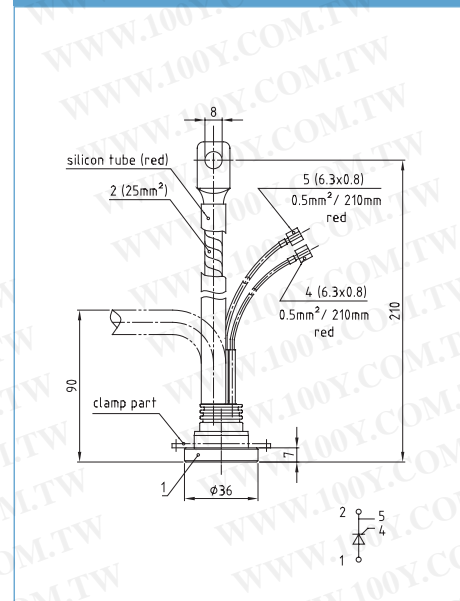

TSW41

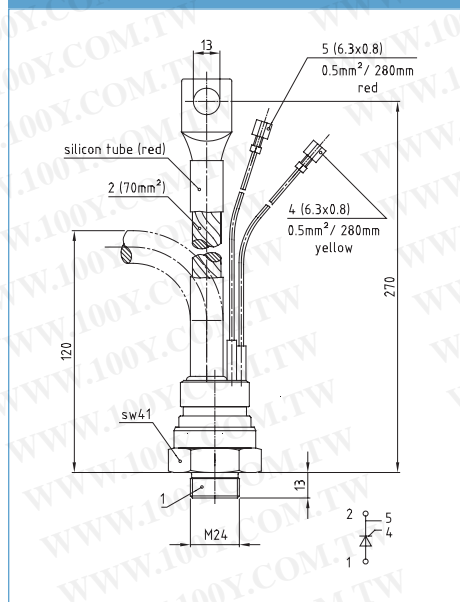

TFL54

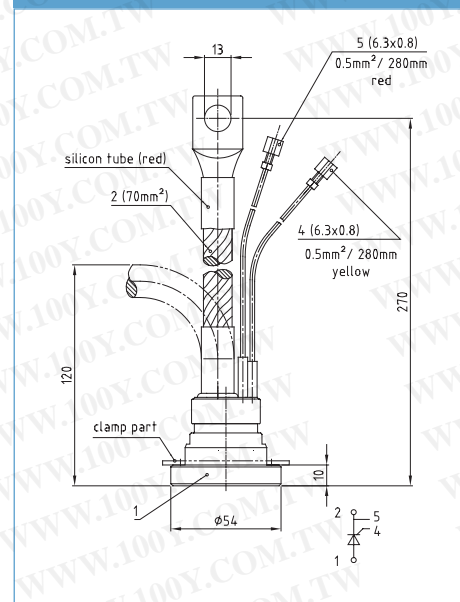

T41.14

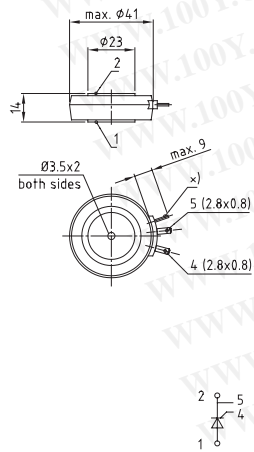

T50.14

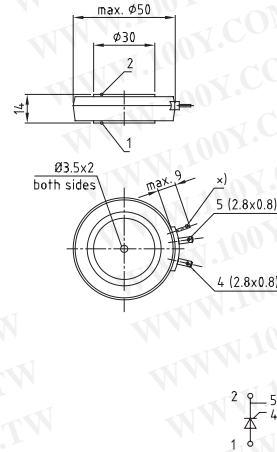

T57.26

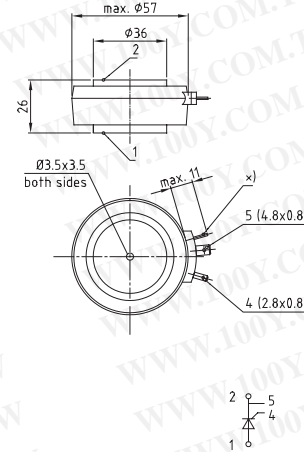

T60.14

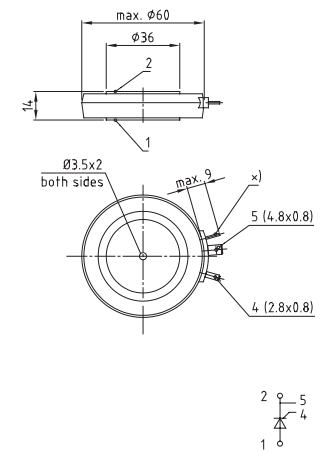

T75.26

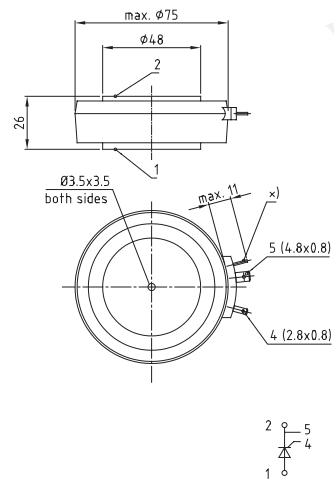

T100.26

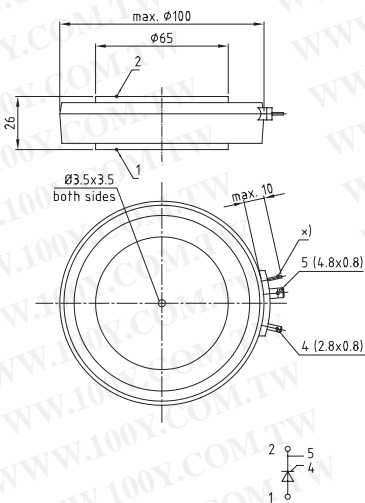

T110.26

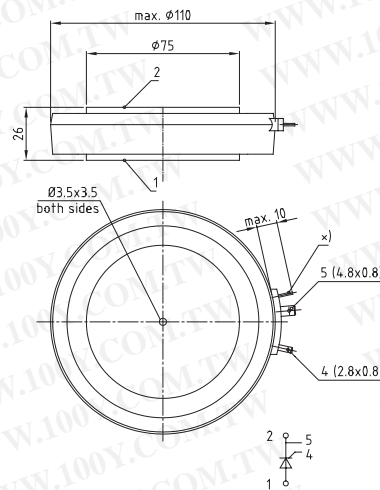

T110.35

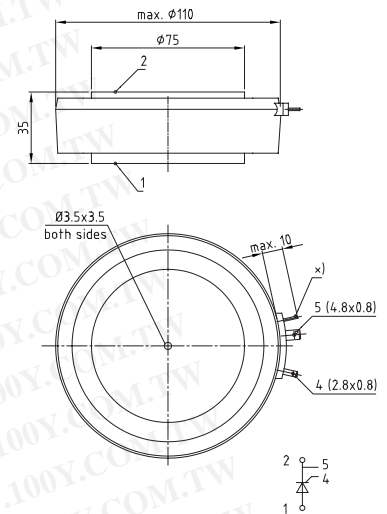

T57.26K

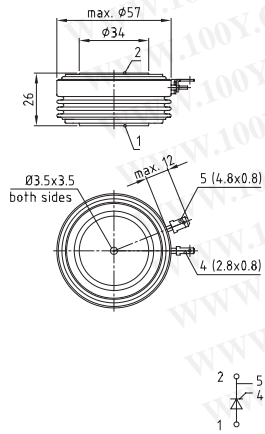

T58.26K

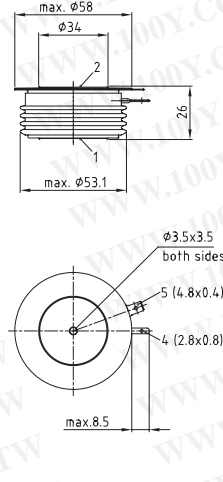

T75.26K

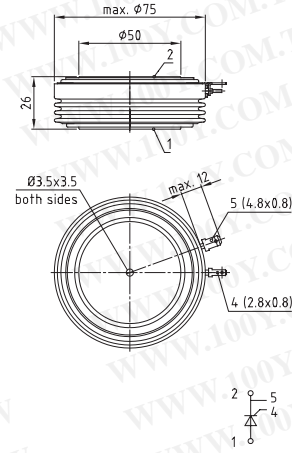

T76.26K

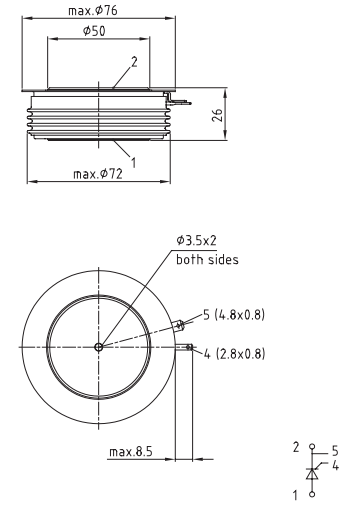

T76.35K

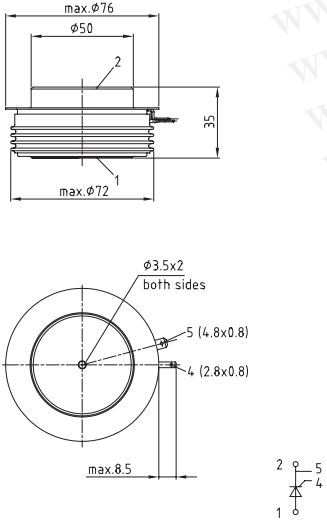

T100.26K

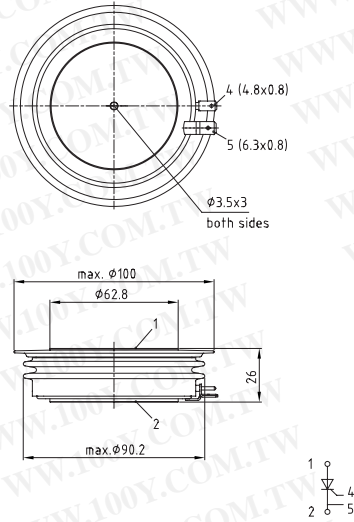

T120.26K

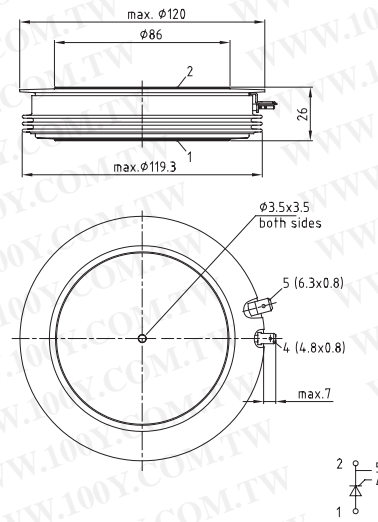

T120.26K.1

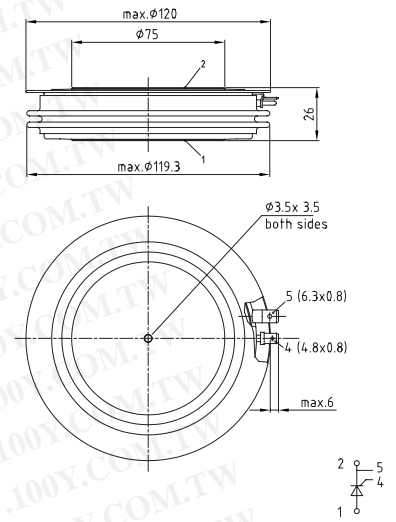

T120.35K

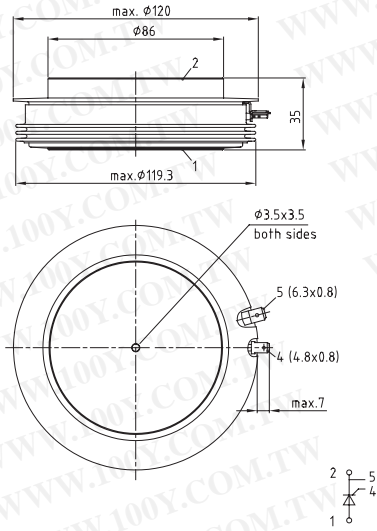

T120.35K.1

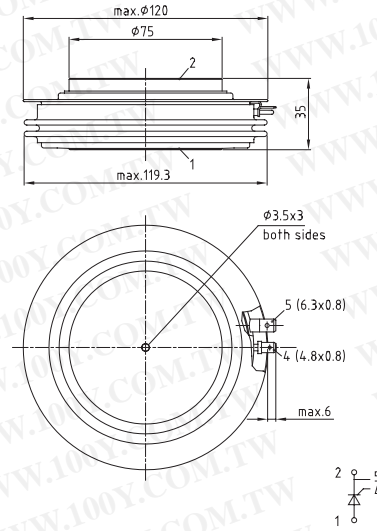

T120.35K.2

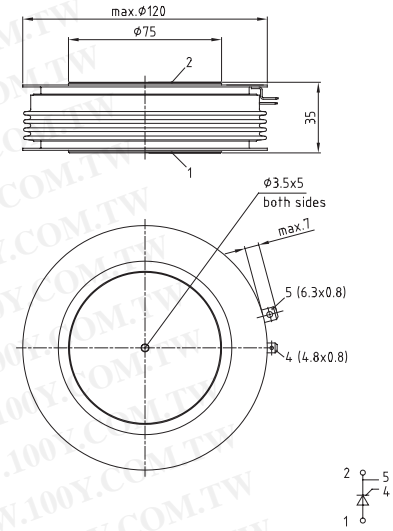

T150.26K

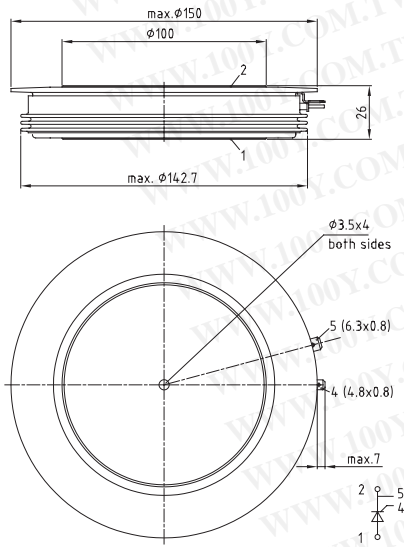

T150.35K

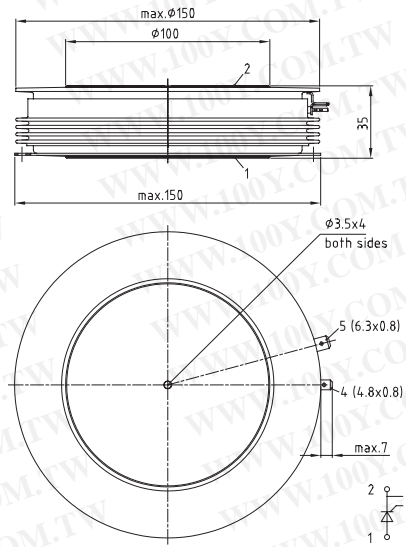

T172.40K

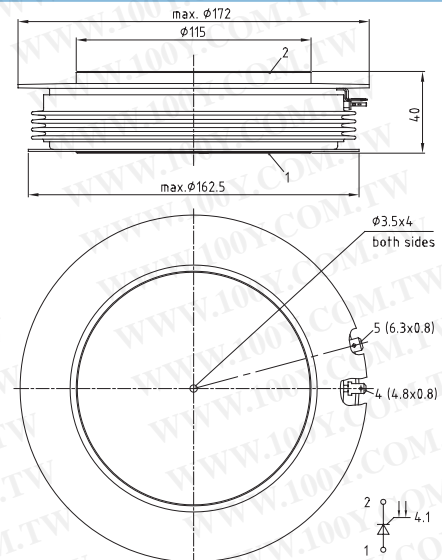

T76.35L

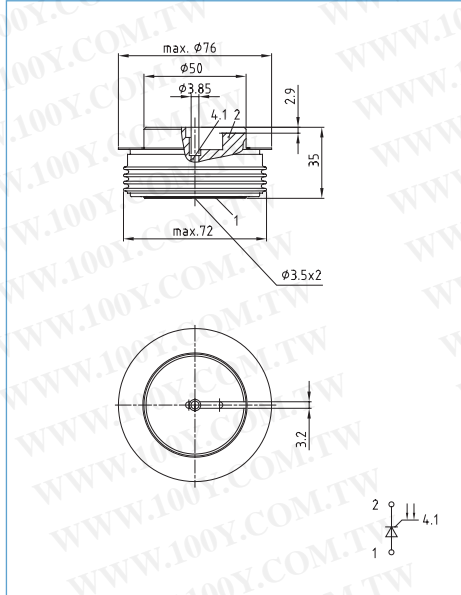

T150.40L

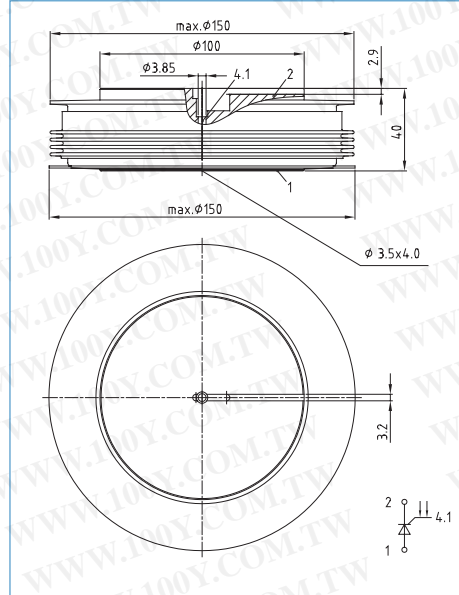

T172.40L

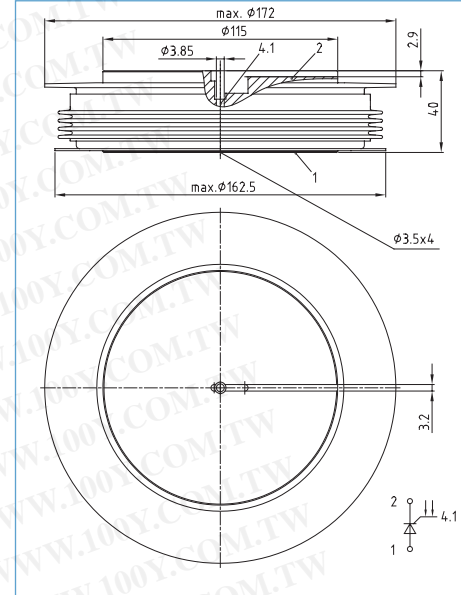

DSW27

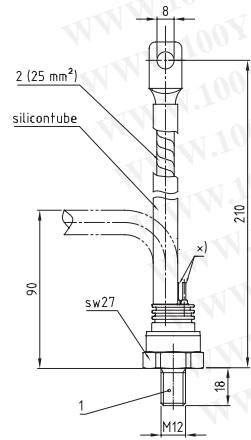

type	symbol	cathode	anode	prof. flex. tubing
N, S	⌞	rope (2)	case (1)	red
K, U	⌞	case (1)	rope (2)	blue

DSW27.1

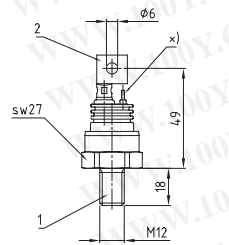

type	symbol	cathode	anode
N, S	⌞	connection pin (2)	case (1)
K, U	⌞	case (1)	connection pin (2)

DSW27.2

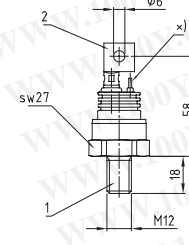

type	symbol	cathode	anode
N, S	⌞	connection pin (2)	case (1)
K, U	⌞	case (1)	connection pin (2)

DFL36

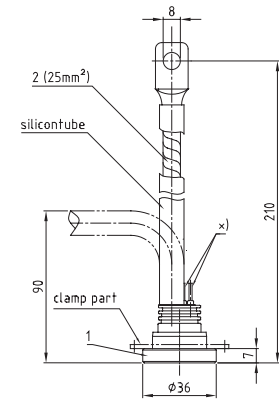

type	symbol	cathode	anode	prof. flex. tubing
N, S	⌞	rope (2)	case (1)	red
K, U	⌞	case (1)	rope (2)	blue

DSW41

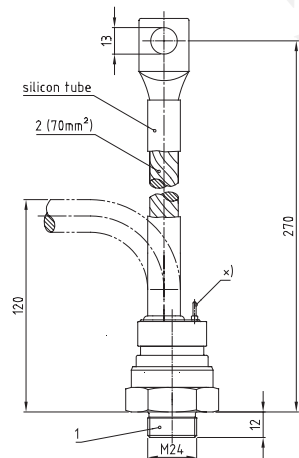

type	symbol	cathode	anode	prof. flex. tubing
N, S	⌞	rope (2)	case (1)	red
K, U	⌞	case (1)	rope (2)	blue

DSW41.1

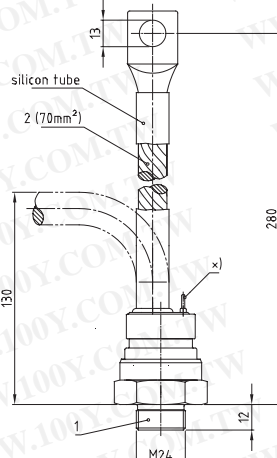

type	symbol	cathode	anode	prof. flex. tubing
N, S	⌞	rope (2)	case (1)	red
K, U	⌞	case (1)	rope (2)	blue

DFL54

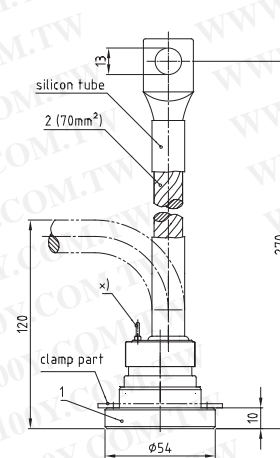

type	symbol	cathode	anode	prof. flex. tubing
N, S	⌞	rope (2)	case (1)	red
K, U	⌞	case (1)	rope (2)	blue

D41.14

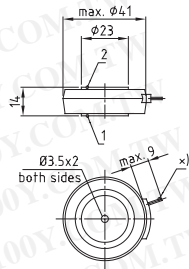

D50.14

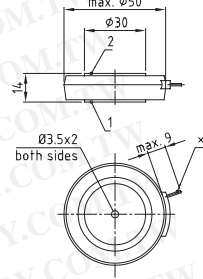

D57.26

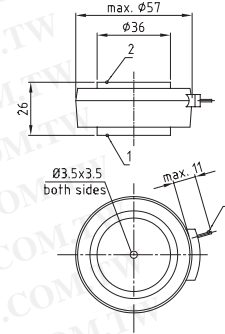

D60.8

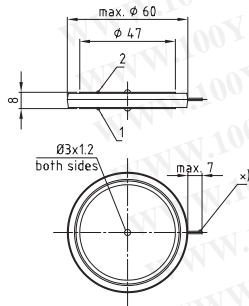

D60.14

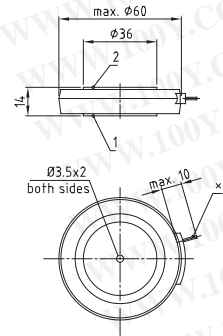

D73.8

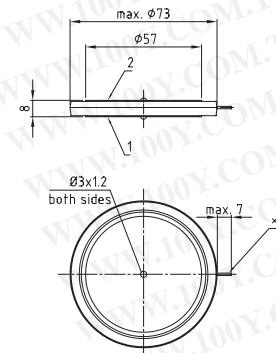

D75.14

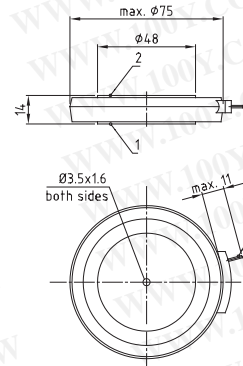

D75.26

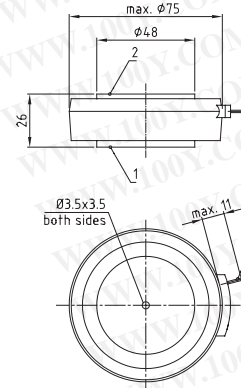

D100.26

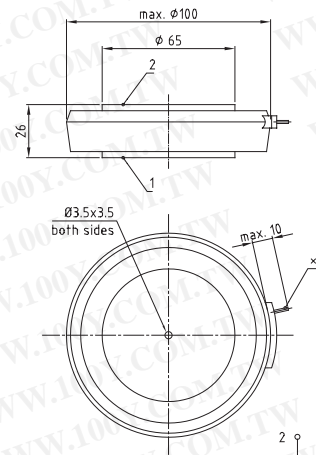

D110.26

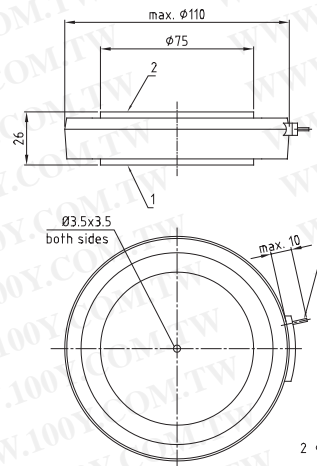

D41.14K

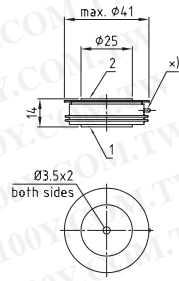

D57.26K

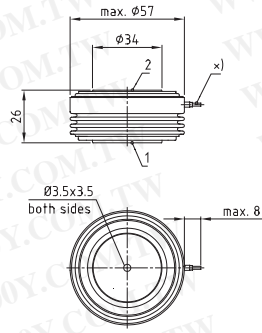

D58.26K

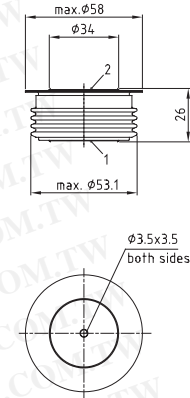

D75.26K

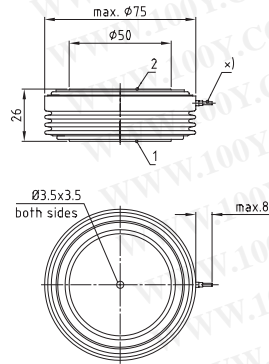

D76.14K

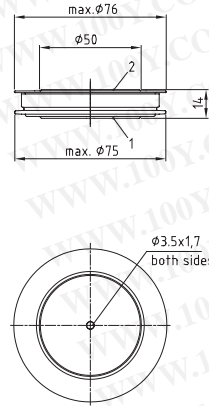

D76.26K

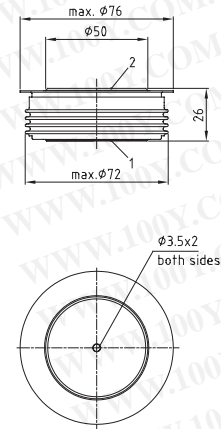

D100.14K

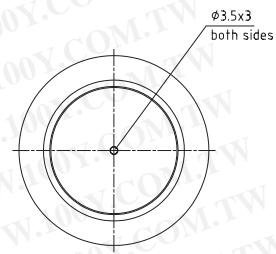
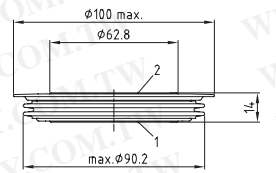

D100.26K

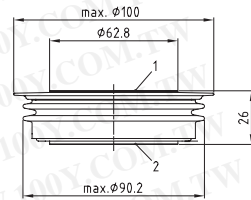
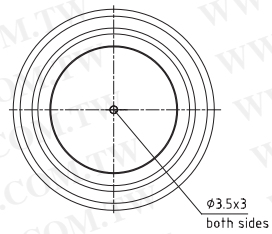

D120.26K

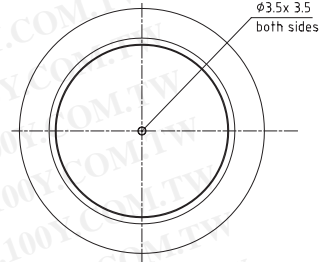
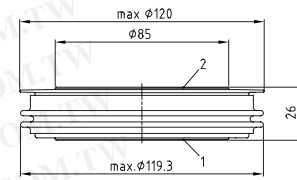

D120.35K

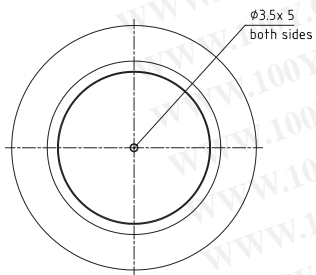
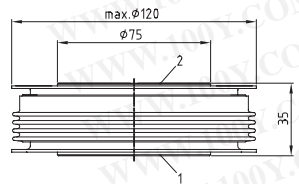

D150.26K

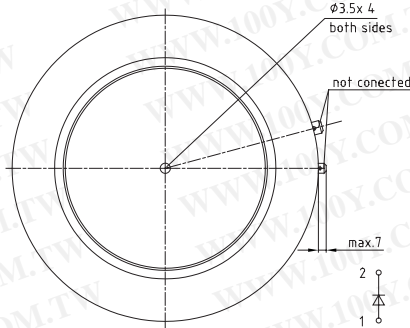
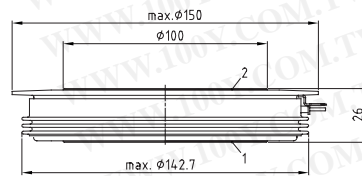

25DN06

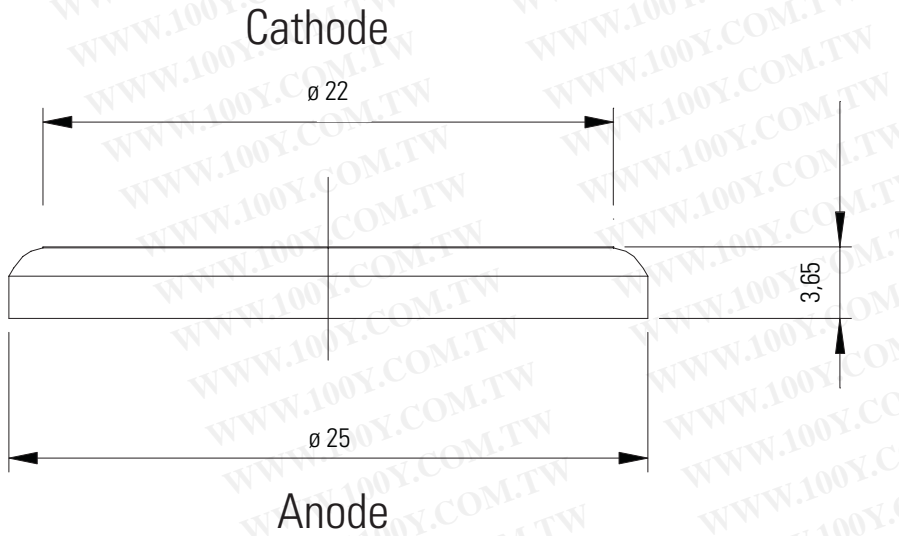

46DN06

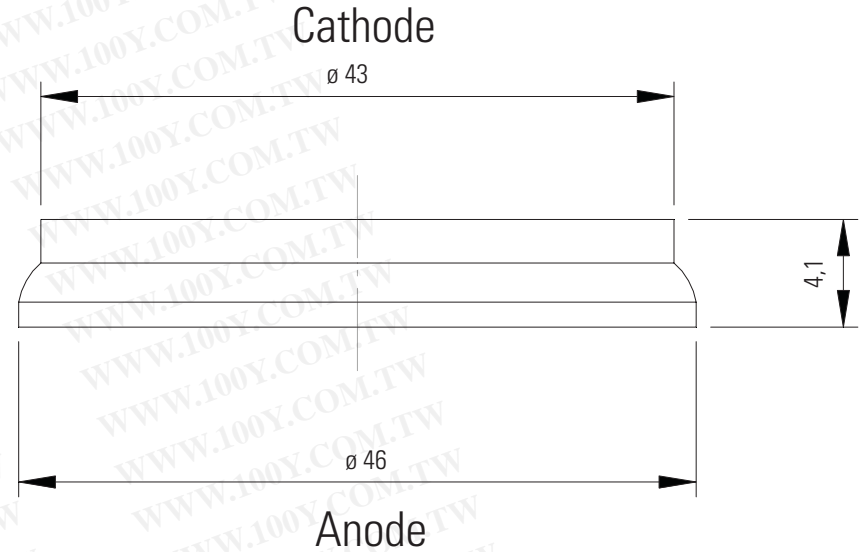

56DN06

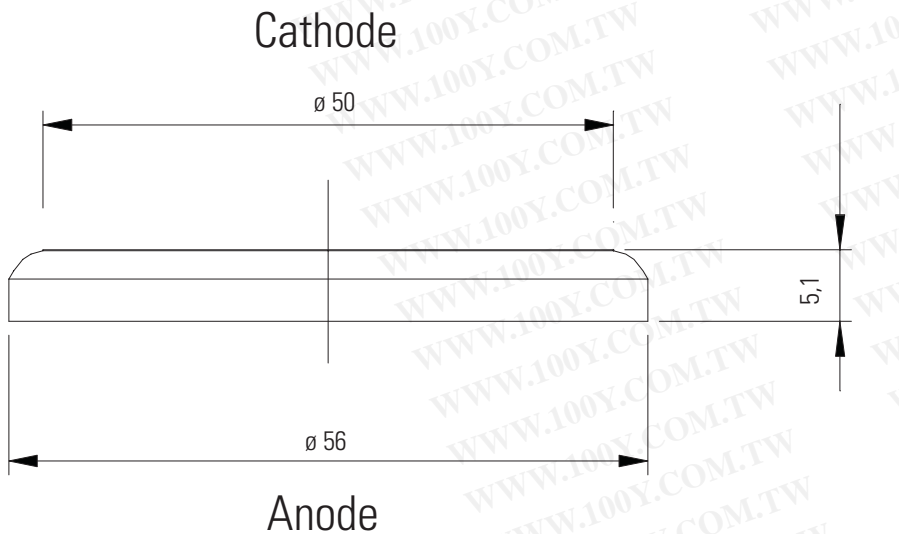

65DN06

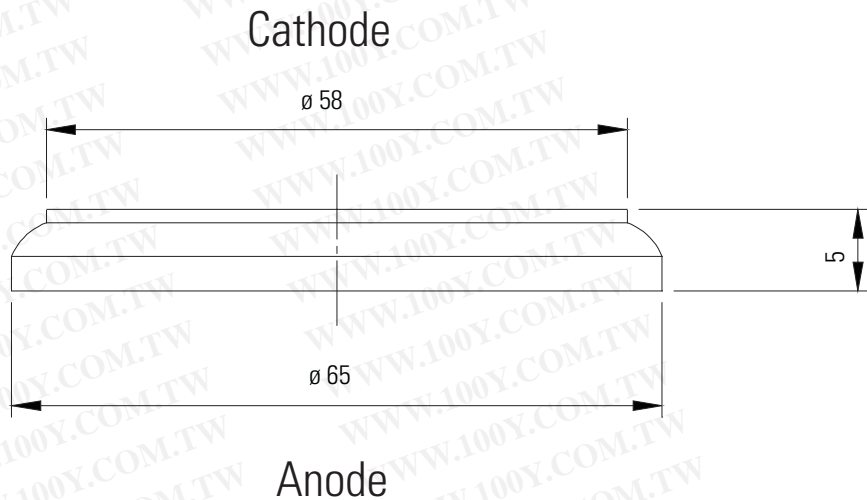

157.26

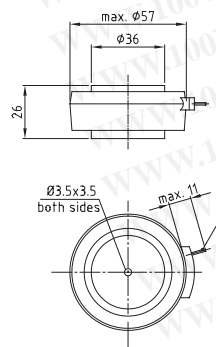

165.35

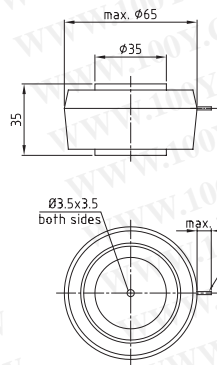

172.8

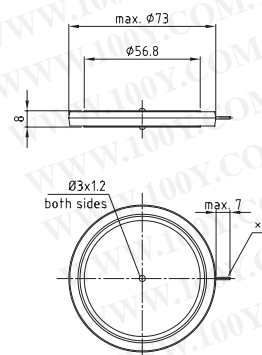

175.14

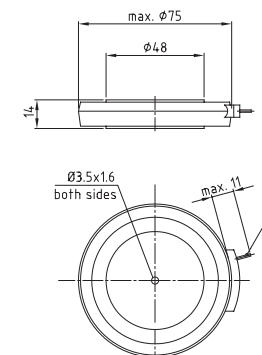

175.26

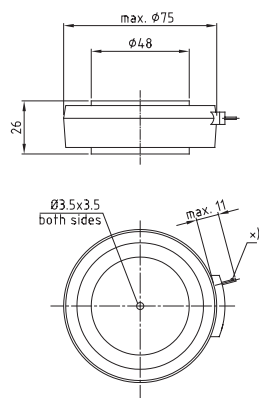

1120.35

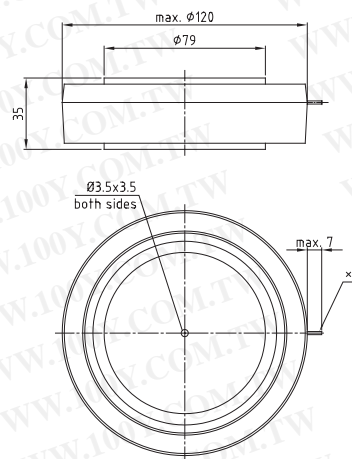

1120.59

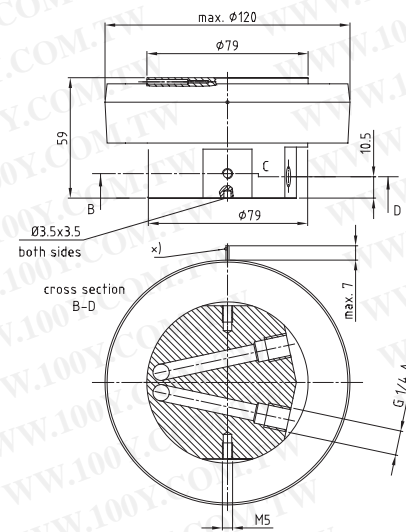

SZ 1

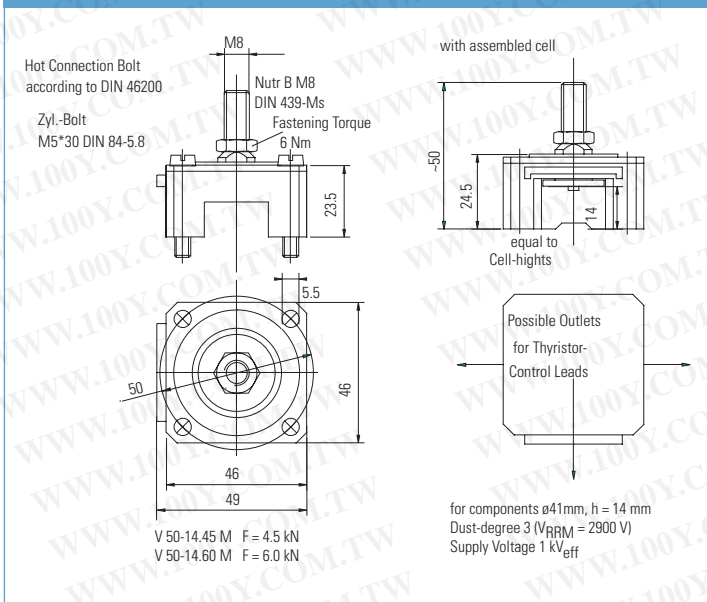

SZ 2

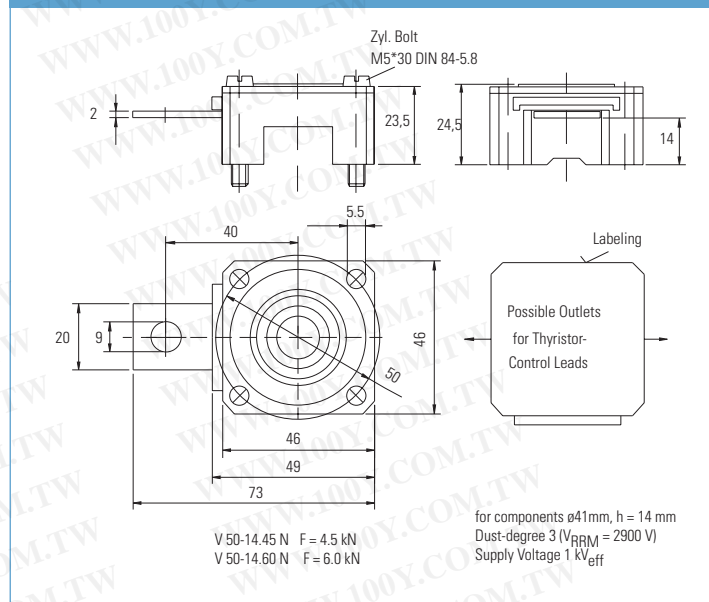

SZ 3

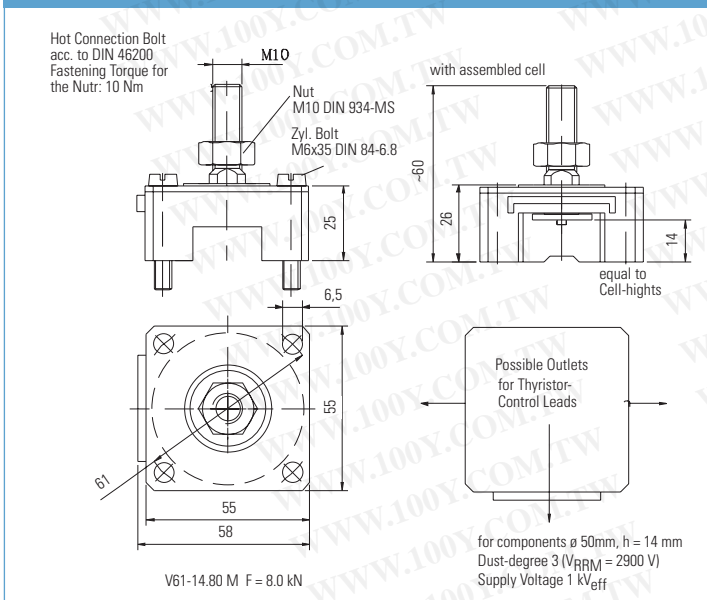

SZ 4

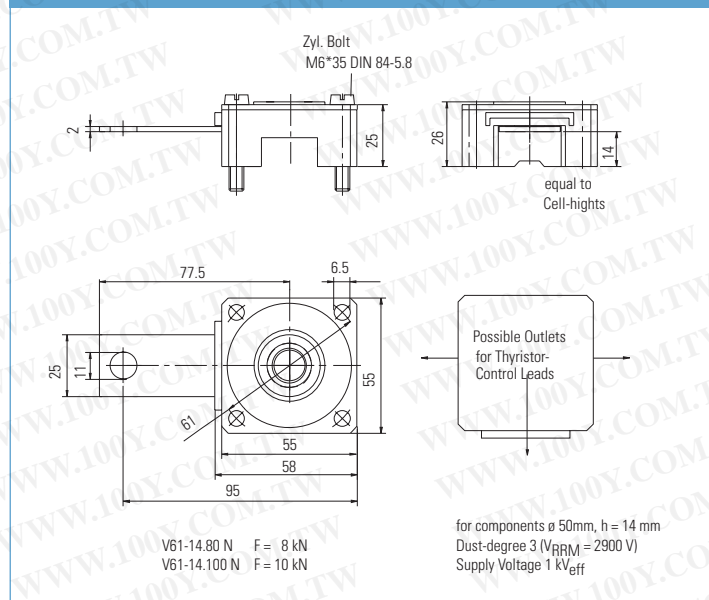

SZ 5

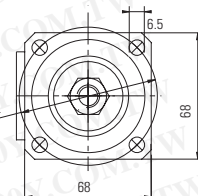
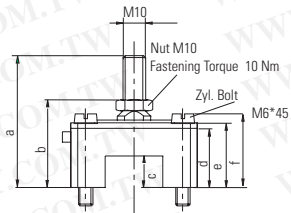

for components $\phi 60\text{mm}$, $h = 14/26\text{ mm}$
Dust-degree 3 ($V_{RRM} = 4000/5000\text{ V}$)
Supply Voltage 1.4/1.8 kV_{eff}

Clamping device	c	l	a	b	d	e	f	F	U _{eff}
V72-14.150M	14	45	68	49	32	36	40,5	15 kN	1400V
V72-26.150M	26	60	80	61	44	48	52,5	15 kN	1800V
V72-26.80 M	26	60	80	61	44	48	52,5	8 kN	1800V
V72-26.120M	26	60	80	61	44	48	52,5	12 kN	1800V
V72-26.120MS	26	60	80	61	44	49	53,5	12 kN	2100V

161

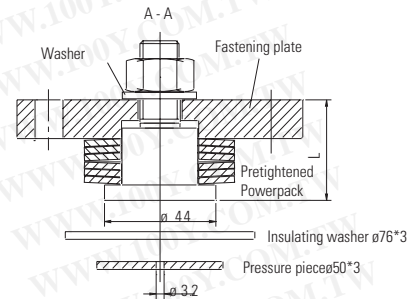

#) Bolts and Nuts for assembling, insulating pipes and pressure piece are not included in the delivery

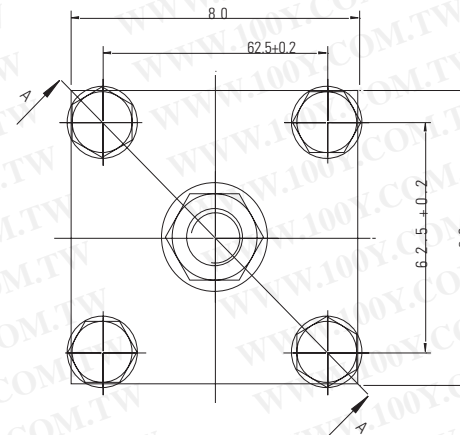

V89-26.400 N: F = 40 kN L = 38 mm
V89-26.300 N: F = 30 kN L = 39 mm
V89-26.170 N: F = 17 kN L = 40 mm

For max. 1.0 kV_{eff} applications

SZ 6

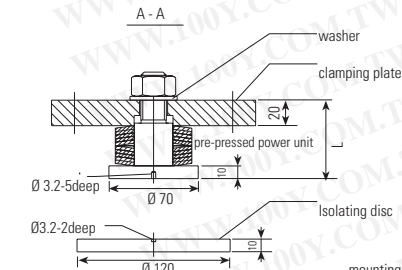

mounting instructions:
- part are to be centered
- the clamping plate must be fixed equally with 4 Bolts M12 - 8.8 (not included) until the washer is untight up to a gap of 0.2 mm.
- glue untightened washer to avoid noises

For max. 2.5 kV_{eff} applications

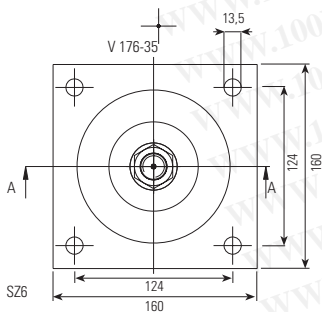

Type	Mat.-No.	clamping force	L
V176-35.650N	19610	65KN	57.5
V176-35.500N	19611	50KN	58.5
V176-35.400N	19612	40KN	59.5

IGBT Drivers

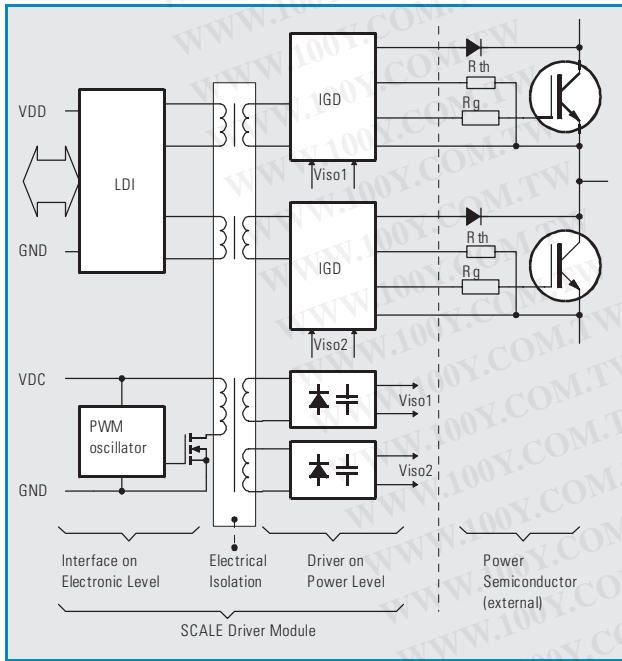

Block diagram shows 2 channels (i.e. one third of the 6SD 106E1-17)

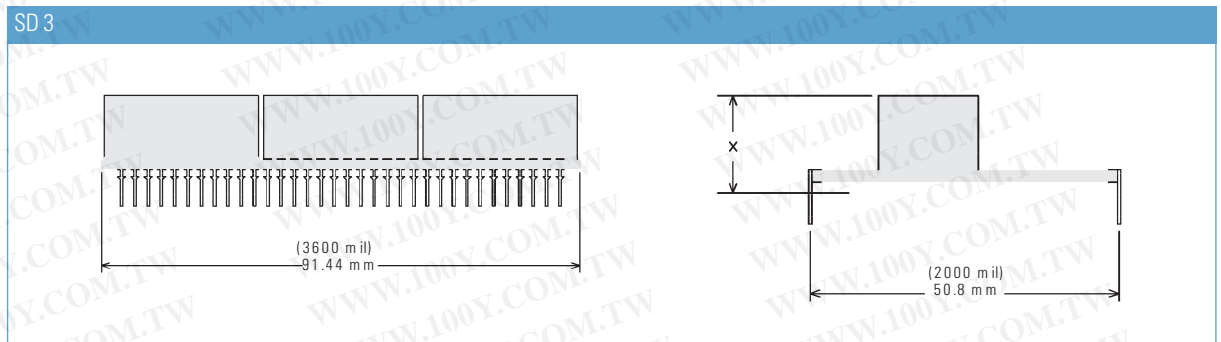
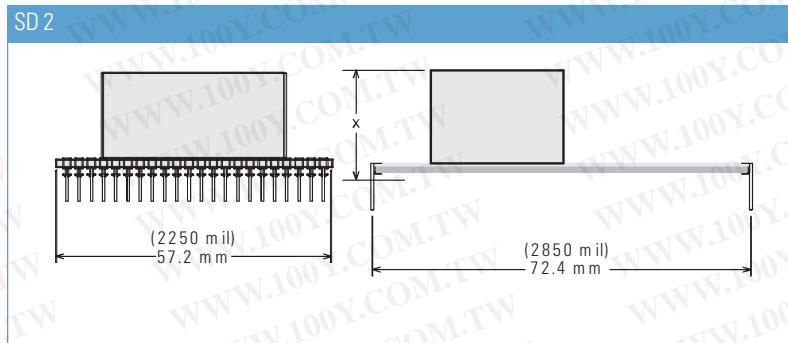
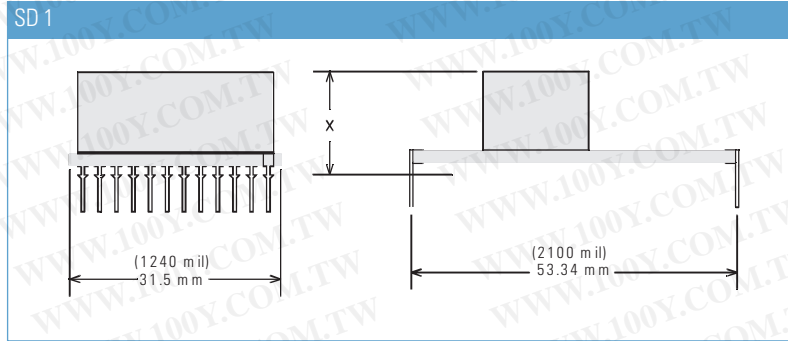

Outline 1

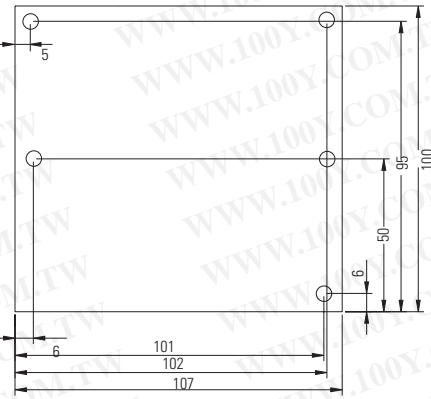

Outline 2

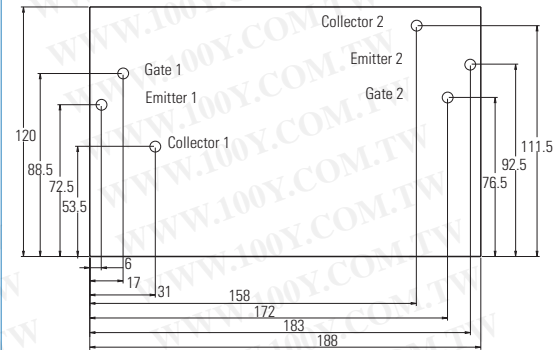

Outline 3

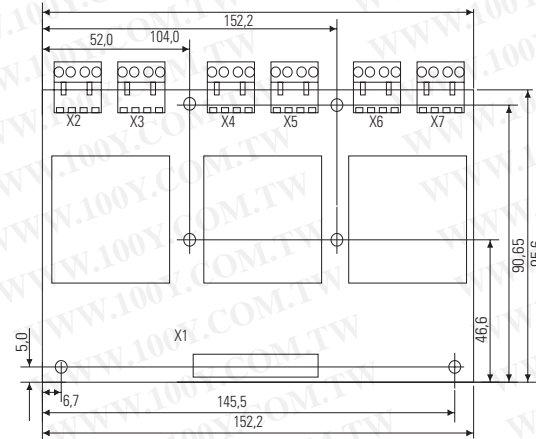

Outline 4

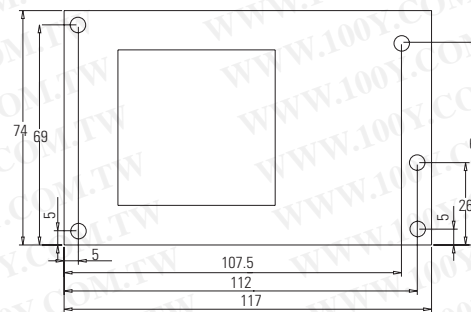

Outline 5

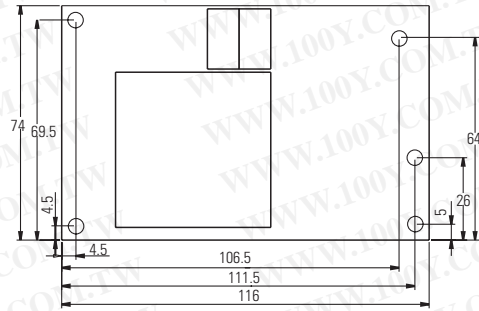

Outline 6

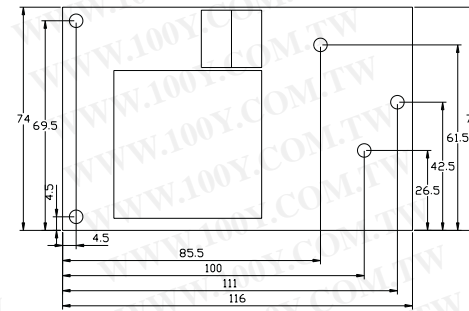

Outline 7

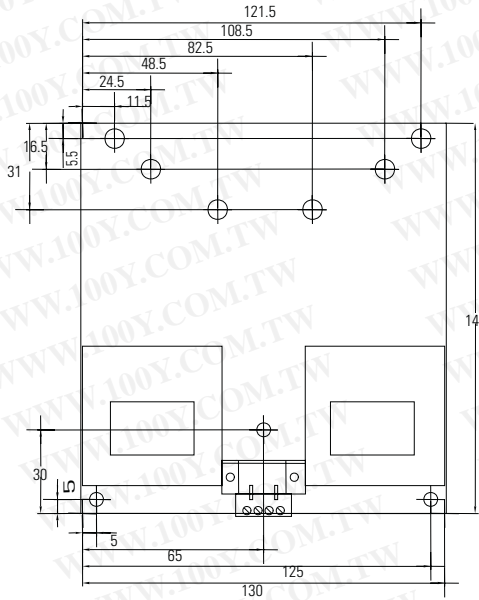

Outline 8

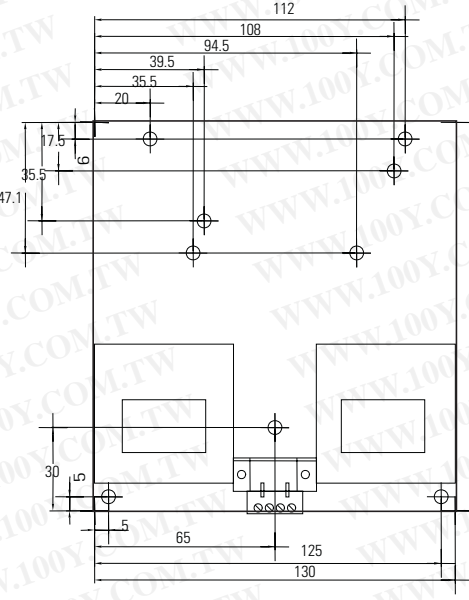

Gate Leads for Thyristor Modules

Leads and gate strands must be ordered separately

Baseplate	connection to	part no.	Outline
20 mm	4/5	2391	LZ1
	6/7	2392	LZ2
25 mm	4/5	4301	LZ3
	6/7	4303	LZ4
30 mm	4/5	4305	LZ5
	6/7	4307	LZ6
34, 50, 60 mm	5/4	12669	LZ7
	6/7	12711	LZ8
50 mm-Single	5/4	12669	LZ7
70 mm-Single	5/4	12711	LZ8

The strands consist of copper, 0,5 mm² and are insulated with silicon rubber 0,6 mm.

Operating voltage: 380 V_{eff}

Test voltage: 2000 V_{RMS}

Breakdown voltage min 3000 V

Temperature range: - 50 °C/+ 180 °C

Mounting Hardware for Modules

Type	Content	Quantity	Part-No.
IsoPACK 42	M5x11	30	4195
IsoPACK 54	M6x15	30	4210

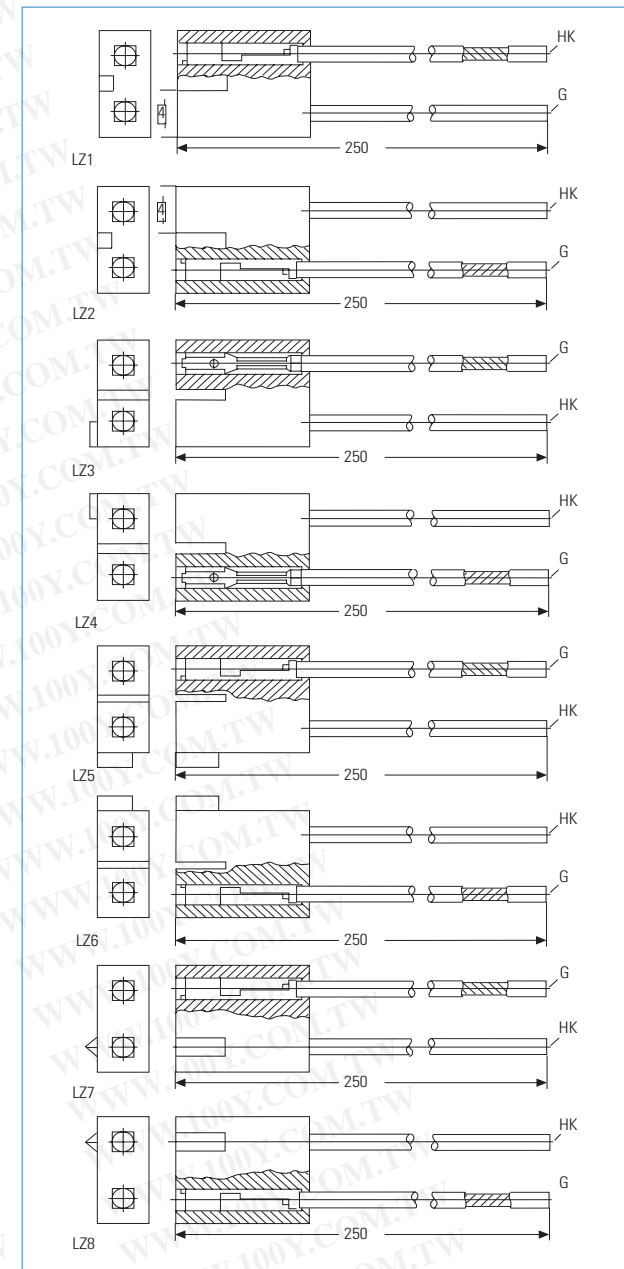

Standard Gate Leads for Disc Type Devices

Leads and gate leads must be ordered separately

Disc outline/page	Material	Mat. no.	Connection	Color	Length mm
T41.14/75	epoxy	2385	HK	red	225
		2386	G	yellow	225
T50.14/75	epoxy	2385	HK	red	225
		2386	G	yellow	225
T60.14/75	epoxy	2387	HK	red	225
		2386	G	yellow	225
T57.26/75	epoxy	2387	HK	red	225
		2386	G	yellow	225
T75.26/76	epoxy	2387	HK	red	225
		2386	G	yellow	225
T57.26K/76	ceramic	2387	HK	red	225
		2386	G	yellow	225
T120.35K.2/76	ceramic	2390	HK	red	225
		2386	G	yellow	225
T150.35K/76	ceramic	2390	HK	red	225
		2386	G	yellow	225
T75.26K/77	ceramic	2387	HK	red	225
		2386	G	yellow	225
T58.26K/79	ceramic	2387	HK	red	225
		2386	G	yellow	225
T76.26K/79	ceramic	2387	HK	red	225
		2386	G	yellow	225

All gate connection leads with plug 6,3 x 1 mm at the free ends.

Lead material: silicon cord type SIFF 0,5 mm²

Lead material no. 2390 is not standard stock material.

Clamping Force (kN) and Disc Diameter (mm)

Phase control thyristors			Phase control thyristors			Phase control thyristors			Phase control thyristors		
Typ	kN	mm	Typ	kN	mm	Typ	kN	mm	Typ	kN	mm
T 178 N	2,5 - 5	41	T 739 N	15 - 24	75	T 1869 N	30 - 65	100	Fast Thyristors		
T 201 N	7 - 12	58	T 821 N	27 - 40	100	T 1901 N	63 - 91	150			
T 218 N	2,5 - 5	41	T 828 N	5,5 - 8	50	T 1929 N	42 - 95	110	T 128 F	3 - 6	41
T 268 N	5 - 10	50	T 829 N	12 - 29	75	T 1971 N	36 - 52	120	T 178 F	1,5 - 2,5	41
T 298 N	3 - 6	41	T 860 N	20 - 45	74	T 1989 N	30 - 65	100	T 188 F	3 - 6	41
T 308 N	5 - 10	50	T 869 N	20 - 45	75	T 2001 N	36 - 52	120	T 308 F	2,5 - 5	41
T 348 N	2,5 - 5	41	T 878 N	10,5 - 21	60	T 2006 N	36 - 52	110	T 318 F	5,5 - 10	50
T 358 N	4 - 8	41	T 879 N	10,5 - 21	75	T 2009 N	36 - 52	110	T 358 S	4,5 - 9	50
T 378 N	4 - 8	41	T 901 N	15 - 24	75	T 2101 N	36 - 52	120	T 408 F	5 - 10	50
T 379 N	10,5 - 21	57	T 909 N	15 - 24	75	T 2156 N	42 - 95	110	T 468 S	7 - 15	60
T 380 N	7,5 - 17,5	56	T 929 N	20 - 45	75	T 2159 N	42 - 95	110	T 510 S	7 - 15	56
T 388 N	5 - 10	50	T 1039 N	16 - 32	75	T 2160 N	42 - 95	120	T 599 F	9 - 18	57
T 398 N	3 - 6	41	T 1049 N	12 - 24	75	T 2161 N	45 - 65	120	T 600 F	9 - 18	56
T 399 N	7,5 - 17,5	57	T 1050 N	20 - 45	75	T 2301 N	63 - 91	150	T 698 F	5,5 - 11	50
T 458 N	7,5 - 17,5	60	T 1059 N	20 - 45	75	T 2351 N	45 - 65	120	T 930 S	16 - 32	74
T 459 N	7,5 - 17,5	57	T 1078 N	8 - 16	50	T 2401 N	63 - 91	150	T 1052 S	16 - 32	74
T 501 N	15 - 24	75	T 1081 N	36 - 52	120	T 2451 N	63 - 91	150	T 1078 F	8 - 16	50
T 508 N	5 - 10	50	T 1101 N	27 - 40	100	T 2476 N	42 - 95	110	T 1101 S	27 - 39	100
T 509 N	5 - 10	57	T 1189 N	16 - 32	75	T 2479 N	42 - 95	110			
T 551 N	15 - 24	75	T 1200 N	20 - 45	74	T 2509 N	24 - 56	75	Fast Asymmetric Thyristors		
T 553 N	15 - 24	75	T 1201 N	36 - 52	120	T 2551 N	36 - 52	120			
T 568 N	4 - 8	41	T 1209 N	20 - 45	75	T 2561 N	90 - 130	170	A 158 S	2,5 - 4,5	41
T 588 N	6 - 12	50	T 1219 N	20 - 45	75	T 2563 N	90 - 130	170	A 198 S	2,5 - 4,5	41
T 589 N	6 - 12	57	T 1258 N	12 - 24	60	T 2601 N	63 - 91	150	A 358 S	4,5 - 9	50
T 618 N	6 - 12	50	T 1321 N	36 - 52	120	T 2651 N	36 - 52	120	A 438 S	4,5 - 9	50
T 619 N	6 - 12	57	T 1329 N	20 - 45	75	T 2709 N	42 - 95	110	A 901 S	13,5 - 24	75
T 648 N	9 - 18	50	T 1401 N	36 - 52	120	T 2710 N	42 - 95	120	A 931 S	13,5 - 24	75
T 649 N	9 - 18	57	T 1451 N	36 - 52	120	T 2851 N	63 - 91	150			
T 658 N	10,5 - 21	60	T 1500 N	24 - 56	74	T 3101 N	63 - 91	150			
T 659 N	10,5 - 21	57	T 1501 N	63 - 91	150	T 3159 N		110			
T 699 N	10,5 - 21	57	T 1503 N	63 - 91	150	T 3401 N	63 - 91	150			
T 708 N	10,5 - 21	60	T 1509 N	24 - 56	75	T 3709 N	30 - 65	100			
T 709 N	12 - 29	75	T 1549 N	42 - 95	110	T 4001 N	90 - 130	170			
T 718 N	9 - 18	60	T 1551 N	36 - 52	120	T 4003 N	90 - 130	170			
T 719 N	9 - 18	57	T 1589 N	30 - 65	100	T 4301 N	63 - 91	150			
T 729 N	18 - 43	75	T 1601 N	36 - 52	120	T 4771 N	63 - 91	150			
T 730 N	18 - 43	75	T 1791 N	36 - 52	120						
T 731 N	15 - 24	75	T 1851 N	45 - 65	120						

Clamping Force (kN) and Disc Diameter (mm)

Rectifier diodes			Rectifier diodes			Fast rectifier diodes			Fast rectifier diodes		
Typ	kN	mm	Typ	kN	mm	Typ	kN	mm	Typ	kN	mm
D 269 N	3,2 - 7,6	57	D 5807 N	40 - 60	72	D 138 S	1,7 - 3,4	41	D 1331 SH	36 - 52	120
D 428 N	3,2 - 7,6	41	D 5809 N	30 - 60	75	D 178 S	1,7 - 3,4	41	D 1251 S	15 - 36	75
D 448 N	2,6 - 4,6	41	D 8019 N	40 - 80	100	D 188 S	1,7 - 3,4	41	D 1181 SX	27 - 45	100
D 471 N	10 - 16	58				D 228 S	3,2 - 7,6	41	D 1381 S	27 - 45	100
D 660 N	6,1 - 14,7	41				D 238 S	3,2 - 7,6	41	D 1408 S	18 - 50	75
D 711 N	10 - 16	58				D 261 S	9 - 13	58	D 1461 S	27 - 45	100
D 748 N	6,1 - 14,7	50				D 271 S	9 - 13	58	D 1641 SX	27 - 45	100
D 749 N	10 - 24	57				D 281 S	10 - 16	58	D 1951 SH	55 - 91	150
D 758 N	3,2 - 7,6	41				D 291 S	9 - 13	58			
D 798 N	6 - 14,7	50				D 348 S	3,2 - 7,6	41			
D 849 N	10 - 24	57				D 358 S	3,2 - 7,6	41			
D 850 N	10 - 24	56				D 368 S	3,2 - 7,6	41			
D 1029 N	10 - 24	57				D 371 S	10 - 16	58			
D 1030 N	10 - 24	56				D 438 S	4,8 - 11,4	41			
D 1049 N	10 - 24	57				D 440 S	4,8 - 11,4	56			
D 1069 N	14 - 34	75				D 509 S	6 - 14,5	57			
D 1481 N	15 - 36	75				D 648 S	6 - 14,5	50			
D 1709 N	12 - 24	75				D 649 S	6 - 14,5	57			
D 1800 N	24 - 60	74				D 658 S	6 - 14,5	50			
D 1809 N	24 - 60	75				D 659 S	6 - 14,5	57			
D 2151 N	27 - 45	100				D 675 S	10 - 24	56			
D 2200 N	24 - 60	74				D 689 S	10 - 24	57			
D 2001 N	27 - 45	100				D 721 S	15 - 36	75			
D 2209 N	24 - 60	75				D 801 S	15 - 36	75			
D 2228 N	12 - 24	60				D 841 S	15 - 36	75			
D 2601 N	36 - 52	120				D 901 S	27 - 45	100			
D 2650 N	24 - 60	74				D 911 SH	27 - 45	100			
D 2659 N	24 - 60	75				D 921 S	27 - 45	100			
D 3001 N	36 - 52	120				D 1031 SH	27 - 45	100			
D 3301 N	45 - 65	120				D 1081 S	15 - 36	75			
D 3401 N	36 - 52	120				D 1101 S	27 - 45	100			
D 3501 N	36 - 52	120				D 1131 SH	36 - 52	120			
D 4201 N	36 - 52	120				D 1169 S	18 - 50	75			
D 4457 N	30 - 45	60				D 1170 S	8 - 50	74			
D 4709 N	42 - 95	110				D 1181 S	27 - 45	100			

Letter Symbols

B	DC current gain	di_G/dt	rate of rise of gate current	$t_{fb\ min}$	minimum duration of forward base current
FBSOA	forward biased safe operating area	$di_T/dt/di_r/dt$	rate of rise of on-state current	t_{off}	turn-off time
f	frequency	$(di/dt)_{cr}$	critical rate of rise of on-state current	t_{on}	turn-on time
f_o	repetition frequency	L	inductance	t_s	storage time
F	clamping force	M	tightening torque	$t_{vj\ op}$	operating temperature
G	weight	P_{ON}	turn-on dissipation	t_{stg}	storage temperature
I_C	maximum permissible DC collector current	P_{OFF}	turn-off dissipation	V_D	forward off-state voltage
I_{CAVM}	maximum perm. average collector current	P	power dissipation	V_{DM}	forward off-state voltage (peak value)
I_{CES}	collector-emitter cut-off current	P_D	forward off-state dissipation	V_{DRM}	repetitive peak forward off-state voltage
I_{GES}	gate-leakage current	P_G	gate dissipation	V_{DSM}	non-repetitive peak forward off-state voltage
I_{EGS}	gate-leakage current	P_R	reverse power dissipation	V_G	gate voltage
i_{CBO}	collector-base cut-off current	P_{RQ}	turn-off dissipation	V_{GD}	gate non trigger voltage
I_{CRM}	permissible repetitive peak collector current	$P_{TT} + P_{RQ}$	switching dissipation	$V_{GE(th)}$	gate threshold voltage
i_{EBO}	emitter-base cut-off current	P_T/P_F	on-state power dissipation	V_{GT}	gate trigger voltage
i_{FB}	forward base current	P_{TAV}/P_{FAV}	on-state power dissipation (average value)	V_{ISOL}	insulation test voltage
I_{FB}	maximum permissible peak forward current	P_{TT}	turn-on dissipation	V_L	no-load voltage of trigger pulse generator
i_{RB}	reverse base current	P_{tot}	total power dissipation	V_R	reverse voltage
I_{RB}	maximum perm. peak reverse base current	Q_r	recovered charge	V_R	direct reverse voltage
I_D	forward off-state current	Q_s	lag charge	V_{RG}	reverse gate voltage
i_G	gate current	R	resistance	V_{RGM}	peak reverse gate voltage
I_{GD}	gate non trigger current	r_T	slope resistance	V_{RM}	reverse voltage (peak value)
i_{GM}	peak gate current	R_{thCA}	thermal resistance, case to coolant	$V_{RMS} V_{DC}$	RMS or DC voltage value
I_{GT}	gate trigger current	R_{thCK}	thermal resistance, case to heatsink	V_{RRM}	repetitive reverse voltage
I_H	holding current	R_{thJA}	thermal resistance, junction to coolant	$V_{RRM(C)}$	repetitive peak reverse voltage after commutation
I_L	latching current	R_{thJC}	thermal resistance, junction to case	V_{RSM}	non-repetitive peak reverse voltage
i_R	reverse current	RBSOA	reverse biased safe operating area	V_T/V_F	on-state voltage
I_{RMS}	RMS current	t	time	$V_{(TO)}$	threshold voltage
I_{RM}	peak reverse recovery current	T	period	V_M	repetitive peak voltage
i_T/i_F	on-state current	T_A	coolant temperature	$V_{CE\ sat}$	collector-emitter saturation emitter voltage
I_{TAV}/I_{FAV}	on-state current (average value)	T_{IC}	case temperature	V_{CES}, V_{CE}	maximum permissible collector-voltage
I_{TAVM}/I_{FAVM}	maximum average on-state current	T_{oop}	operating temperature	dv_D/dt	rate of rise of forward off-state voltage
I_{TINT}/I_{FINT}	on-state current at intermittent duty	t_g	trigger pulse duration	dv_r/dt	rate of rise of reverse voltage
I_{TM}/I_{FM}	on-state current (peak value)	t_{gd}	gate controlled delay time	$(dv/dt)_{cr}$	critical rate of rise of off-state voltage
$I_{T(OV)}/I_{F(OV)}$	on-state current at shorttime duty	T_K	heatsink temperature	V_L	air quantity
$I_{T(OVM)}/I_{F(OVM)}$	maximum overload on-state current	t_p	current pulse duration (sinusoidal)	V_W	water quantity
$I_{T(RCIM)}$	repetitive turn-on current (from snubber)	t_q	circuit commutated turn-off time	W	energy
I_{TRMSM}/I_{FRMSM}	maximum RMS on-state current	t_{rr}	reverse recovery time	W_{tot}	total energy
I_{TSM}/I_{FSM}	surge non repetitive on-state current	T_{vj}	junction temperature	Z_{thCA}	transient thermal impedance, case to coolant
$I_F(max)$	DC forward current	$T_{vj\ max}$	maximum permissible junction temperature	Z_{thJA}	transient thermal impedance, junction to coolant
I_{FRM}	repetive peak forward current	t_w	current pulse duration (trapezoidal)	Z_{thJC}	transient thermal impedance, junction to case
$\int I^2 dt$	maximum rated value	t_f	fall time	Θ	current conduct. angle

Type designations

Presspacks

T 930 S 18 T M C	
T	thyristor
D	diode
A	asymmetric thyristor
930	average on state current (A)
0	standard ceramic disc
1	high power ceramic disc
4	epoxy disc 19 mm high
6	epoxy disc 35 mm high
7	epoxy disc 8 mm high
8	epoxy disc 14 mm high
9	epoxy disc 26 mm high
3	light triggered thyristor, ceramic disc
N	phase control device
K	phase control diode with cathode on case (only flatbase or metric)
F	fast thyristor with central gate
S	fast thyristor with gate cathode interdigitated, fast diode
U	fast diode with cathode on case (only flatbase or metric)
A	avalanche diode
B	avalanche diode with cathode on case (only flatbase or metric)
18	repetitive peak off-state and reverse voltage in 10 ²
B	metric thread with cable
C	metric thread with solder pin
E	flat base
T	disc
	turn-off time:
A	8 μs
B	10 μs
C	12 μs
D	15 μs
S	18 μs
E	20 μs
F	25 μs
G	30 μs
K	40 μs
M	50 μs
P	55 μs
N	60 μs
T	80 μs

T 930 S 18 T M C	
U	120 μs
O	no guaranteed turn off time
1	see data sheet
2	see data sheet
	critical rate of off-state voltage
B	50 V/μs
C	500 V/μs
F	1000 V/μs
G	1500 V/μs
H	2000 V/μs
	B 1...n construction variation
	S 1...n electrical selection

PowerBLOCK Modules

TT 162 N 16 K O F -K	
TT	with 2 thyristors
DD	with 2 diodes
ND, DZ, TZ	with 1 thyristor or 1 diode
TD, DT	with 1 thyristor and 1 diode
AD	with 1 asymmetric thyristor and 1 diode
162	average on state current (A)
N	phase control device
F	fast thyristor with central gate
S	fast thyristor with gate cathode interdigitated, fast diode
16	repetitive peak off-state and reverse voltage in 10 ²
K	mechanical construction: module
O	turn off time (see disk devices)
F	critical rate of rise of off-state voltage (see disk devices)
-K	design with common cathode
-A	design with common anode
B1...n	construction variation
S1...n	electrical selection

IGBT Modules

IGBT and Diode for IHM/IHV and all new eupec modules	
FF 400 R 33 KF x	example for a High-Power-Module
FZ	single switch with one IGBT and FWD
FF	half bridge
FP	(two IGBTs an FWDs)
FM	Power Integrated Module
FD/DF	Matrix Module
FB	chopper module
	Power Integrated Module with B4 rectifier
DD	dual diode module
F4	4-pack
FS	3 phase full bridge (6-pack)
400	max. DC-collector current (A)
R	reverse conducting
S	fast Diode
33	collector-emitter-voltage in 10 ² V
K	mechanical construction: module
F	fast switching type
L	type with low v _{CEsat}
S	fast short tail IGBT Chip
E	low sat IGBT Chip
1 ... n	internal reference numbers
C	EmCon Diode
D	higher Diode current
-K	design with common cathode
G	module in big housing
I	integrated cooling
B1 ... n	Construction variation
S1 ... n	Electrical selection

Old and topical designation for IGBT and Diode module

BSM 100 GB 120 DL x	example for a standard module
BSM BYM	switch with IGBT and FWD diode module
100	max. DC-collector current (A)
GA	single switch with one IGBT and FWD
GB	half bridge
GD	(two IGBTs and FWDs)
GT	3 phase full bridge (6-pack)
	3 single switches an FWDs (Tripack)

BSM 100 GB 120 DL x	
GP	Power Intergrated Module
	B6/Break/Inverter
GAL	chopper module (diode on collector side)
GAR	chopper module (diode on emitter side)
A	single diode
120	collector-emitter-voltage in 10 ² V
DL	Typ with low v _{CEsat}
DN2	fast switching type
DLC	low loss type with EmCon Diode
S	with collector sense
G	Design Variation
Exxx	special type

Bridge Rectifiers and AC-Switches

TD B6 H K 135 N 16 L OF	
DD	diode module
TT	thyristor module
TD	thyristor/diode
B6	three phase bridge
W3	three phase AC-switch
C	fully controlled
H	half controlled
U	uncontrolled
K	common cathode of thyristors
105	output current (A)
N	(W3C: RMS-current)
16	phase control thyristor/diode
L	repetitive peak off-state voltage in 100 V
R	IsoPACK
RR	Econo2
	Econo2
O	with integr. brake chopper IGBT
F	no guaranteed turn-off time
	critical rate of rise of off-state voltage



www.eupec.com
info.usa@eupec.com

eupec Inc.
1050 Route 22
Lebanon, NJ 08833
Phone (908)236-5600
Fax (908)236-5620

Regional Offices

Eastern Region

eupec Inc.
1050 Route 22
Lebanon, NJ 08833
Phone (908)236-5600
Fax (908)236-5620

eupec Inc.
132 Great Rd., Suite 200
Stow, MA 01775
Phone (978)897-6667

Central Region

eupec Inc.
34930 N. Highway 45
Suite B
Lake Villa, IL 60046
Phone (847)543-9560
Fax (847)543-9654

eupec Inc.
9611 West Forrester Court
Mequon, WI 53097
Phone (262)512-1830
Fax (262)512-0449

eupec Inc.
16690 Champion Forest Drive
PMB 332
Spring, TX 77379-7023
Phone (281)374-7622
Fax (281)374-7621

Western Region

eupec Inc.
700 NW Gilman Blvd.
E-103, Suite 492
Issaquah, WA 98027
Phone (425)396-5060
Fax (425)396-5061

Canada

Please contact eupec's nearest
Regional Office

Latin America

Please contact eupec's Head-
quarters in Lebanon.