



AP431/AP431A

Adjustable Precision Shunt Regulator

■ Features

- Precision reference voltage
AP431 : 2.495V ± 1%
AP431A : 2.495V ± 0.5%
- Sink current capability: 200mA
- Minimum cathode current for regulation: 300 μA
- Equivalent full-range temp coefficient: 30 ppm/°C
- Fast turn-on response
- Low dynamic output impedance: 0.2Ω
- Programmable output voltage to 36V
- Low output noise.
- Packages: TO92, SOT89, SOT23, SOT25 and SOP

■ Description

The AP431/AP431A are 3-terminal adjustable precision shunt regulators with guaranteed temperature stability over the applicable extended commercial temperature range. The output voltage may be set at any level greater than 2.495V(V_{REF}) up to 36V merely by selecting two external resistors that act as a voltage divider network. These devices have a typical output impedance of 0.2Ω. Active output circuitry provides very sharp turn-on characteristics, making these devices excellent improved replacements for Zener diodes in many applications.

The precise (+/-) 1% Reference voltage tolerance of the AP431/431A make it possible in many applications to avoid the use of a variable resistor, consequently saving cost and eliminating drift and reliability problems associated with it.

■ Ordering Information

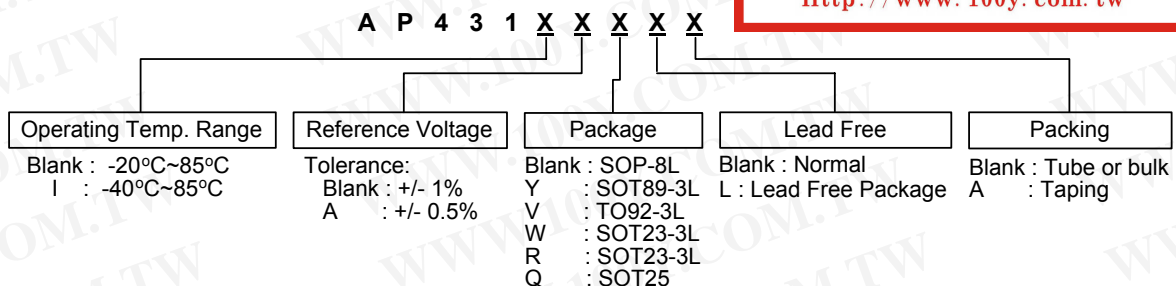

勝特力材料 886-3-5753170
 勝特力电子(上海) 86-21-34970699
 勝特力电子(深圳) 86-755-83298787
[Http://www.100y.com.tw](http://www.100y.com.tw)

■ Typical Application Circuit

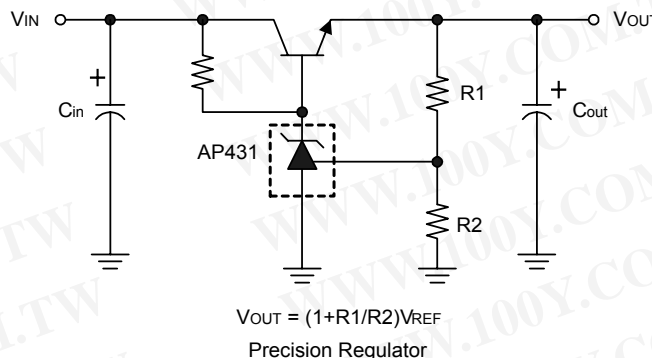



AP431/AP431A

Adjustable Precision Shunt Regulator

■ Block Diagram

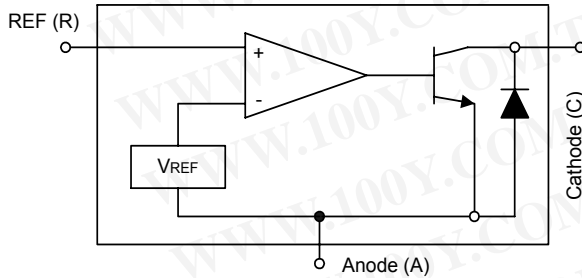

■ Symbol

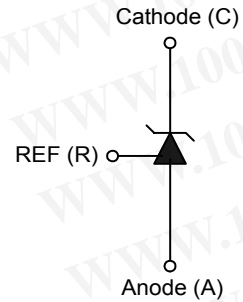

■ Pin Configuration

勝特力材料 886-3-5753170
 勝特力电子(上海) 86-21-34970699
 勝特力电子(深圳) 86-755-83298787
[Http://www.100y.com.tw](http://www.100y.com.tw)

Order Number	Pin Configuration (Top View)	Order Number	Pin Configuration (Top View)
AP431Y AP431AY AP431IY AP431IAY (SOT89)		AP431R AP431AR AP431IR AP431IAR (SOT23)	
AP431V AP431AV AP431IV AP431IAV (TO92)		AP431W AP431AW AP431IW AP431IAW (SOT23)	
AP431 AP431A AP431I AP431IA (SOP)		AP431Q AP431AQ AP431IQ AP431IAQ (SOT25)	



AP431/AP431A

Adjustable Precision Shunt Regulator

■ Marking Information

勝特力材料 886-3-5753170
 勝特力电子(上海) 86-21-34970699
 勝特力电子(深圳) 86-755-83298787
[Http://www.100y.com.tw](http://www.100y.com.tw)

(1) SOT23 / SOT25 / SOT89

P/N Type	X X
AP431Y	A 4
AP431AY	A 5
AP431IY	A A
AP431IAY	A B
AP431W	A 6
AP431AW	A 7
AP431IW	A C
AP431IAW	A D
AP431R	A 8
AP431AR	A 9
AP431IR	A E
AP431IAR	A F
AP431Q	A 2
AP431AQ	A 3
AP431IQ	A G
AP431IAQ	A H

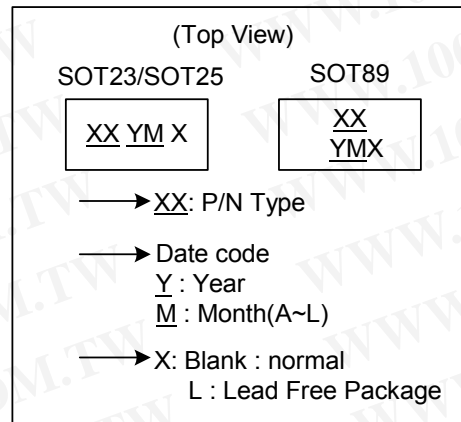

(2) SOP

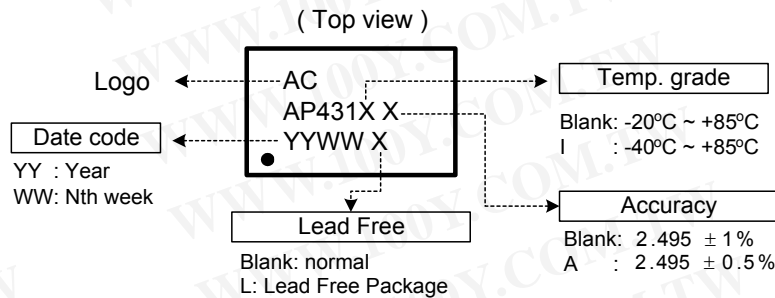

(3) TO92

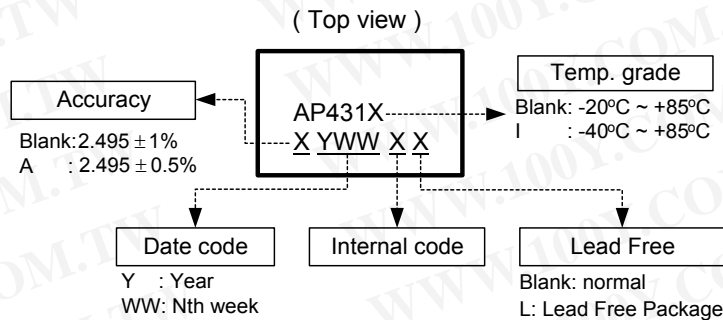



AP431/AP431A

Adjustable Precision Shunt Regulator

■ Absolute Maximum Ratings

Cathode Voltage	36V
Continuous Cathode Current	-10mA ~ 250mA
Reference Input Current Range	10mA
Operating Temperature Range (AP431).....	-20°C ~ 85°C
(AP431I).....	-40°C ~ 85°C
Lead Temperature.....	260°C
Storage Temperature	-65°C ~ 150°C
Power Dissipation (Notes 1, 2)	
SOT89 Package	0.80W
TO92 Package	0.78W
SOT23 package	0.25W
SOT25 Package.....	0.25W
SOP Package.....	0.6W

Note 1: T_J, max =150°C

Note 2: Ratings apply to ambient temperature at 25°C

■ Electrical Characteristics (T_a=25°C, unless otherwise specified.)

PARAMETER	TEST CONDITIONS	SYMBOL	MIN.	TYP.	MAX.	UNIT
Reference voltage	V _{KA} = V _{REF} , I _{KA} = 10mA (Fig.1)	AP431 AP431A	2.470 2.482	2.495	2.520 2.507	V
Deviation of Reference input voltage over temperature (Note 3)	V _{KA} = V _{REF} , I _{KA} = 10mA, T _a = Full range (Fig.1)	V _{REF}		8.0	20	mV
Ratio of the change in Reference voltage to the change in Cathode voltage	I _{KA} = 10mA (Fig.2)	V _{KA} = 10V ~V _{REF}		-1.4	-2.0	mV/V
		V _{KA} = 36V ~10V	ΔV _{KA}		-1	-2
Reference input current	R1 = 10KΩ, R2 = ∞ I _{KA} = 10mA (Fig.2)	I _{REF}		1.4	3.5	μA
Deviation of Reference input current over temperature	R1 = 10KΩ, R2 = ∞ I _{KA} = 10mA T _a = Full range (Fig.2)	αI _{REF}		0.4	1.2	μA
Minimum Cathode current for regulation	V _{KA} = V _{REF} (Fig.1)	I _{KA(MIN)}		0.19	0.5	mA
Off-state current	V _{KA} = 36V, V _{REF} = 0V (Fig.3)	I _{KA(OFF)}		0.1	1.0	μA
Dynamic output impedance (Note 4)	V _{KA} = V _{REF} V _{KA} = V _{REF} ΔI _{KA} = 0.1mA ~ 15mA Frequency ≤ 1KHz (Fig.1)	Z _{KA}		0.2	0.5	Ω

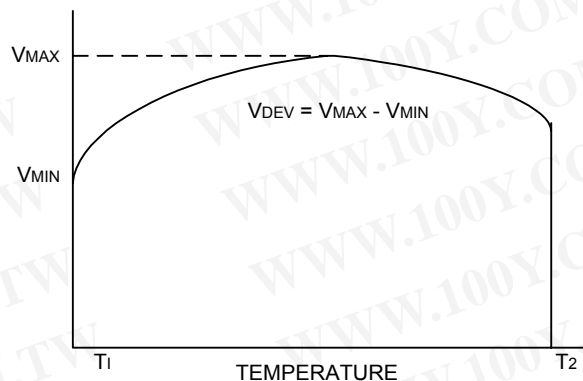

勝特力材料 886-3-5753170
 勝特力电子(上海) 86-21-34970699
 勝特力电子(深圳) 86-755-83298787
[Http://www.100y.com.tw](http://www.100y.com.tw)

Adjustable Precision Shunt Regulator

Note 3. Deviation of reference input voltage, V_{DEV} , is defined as the maximum variation of the reference over the full temperature range.

The average temperature coefficient of the reference input voltage αV_{REF} is defined as:

$$|\alpha V_{REF}| = \frac{\left(\frac{V_{DEV}}{V_{REF}(25^{\circ}\text{C})}\right) \cdot 10^6}{T_2 - T_1} \dots\dots\dots (\text{ppm}/^{\circ}\text{C})$$

Where:

$T_2 - T_1$ = full temperature change.

αV_{REF} can be positive or negative depending on whether the slope is positive or negative.

Note 4. The dynamic output impedance, R_z , is defined as:

$$|Z_{KA}| = \frac{\Delta V_{KA}}{\Delta I_{KA}}$$

When the device is programmed with two external resistors R_1 and R_2 (see Figure 2.), the dynamic output impedance of the overall circuit, is defined as:

$$|Z_{KA}'| = \frac{\Delta V}{\Delta i} \approx |Z_{KA}| \left(1 + \frac{R_1}{R_2}\right)$$

■ Test Circuits

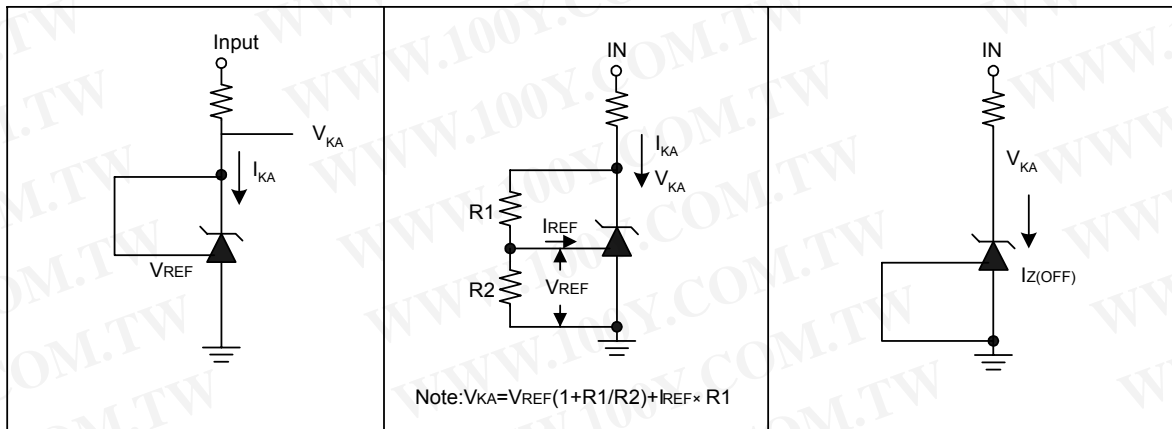

Fig1. Test Circuit for $V_{KA} = V_{REF}$

Fig2. Test circuit for $V_{KA} > V_{REF}$

Fig3. Test Circuit for off-state Current

勝特力材料 886-3-5753170
 勝特力电子(上海) 86-21-34970699
 勝特力电子(深圳) 86-755-83298787
[Http://www.100y.com.tw](http://www.100y.com.tw)



AP431/AP431A

Adjustable Precision Shunt Regulator

■ Typical Performance Characteristics

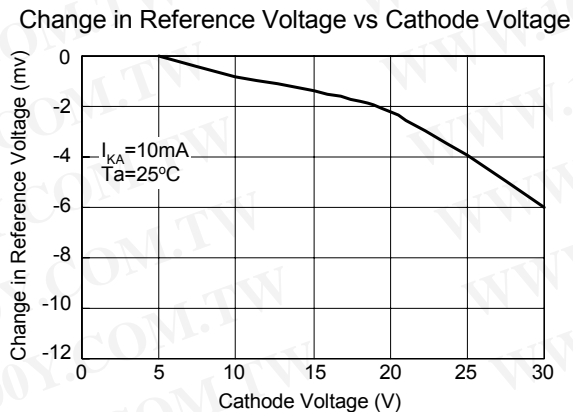
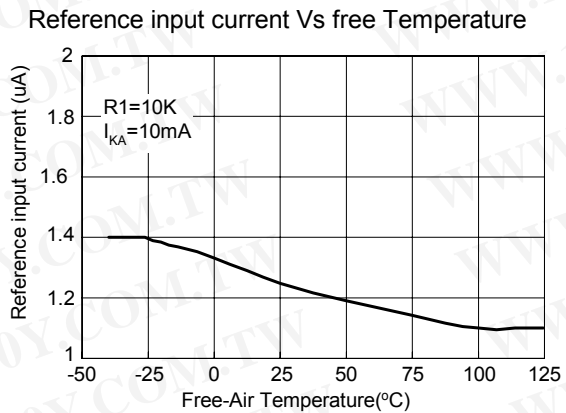
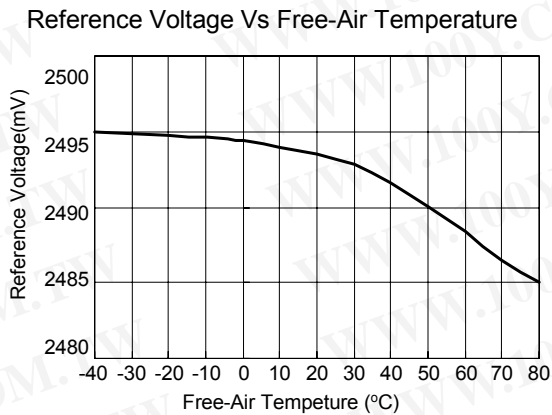
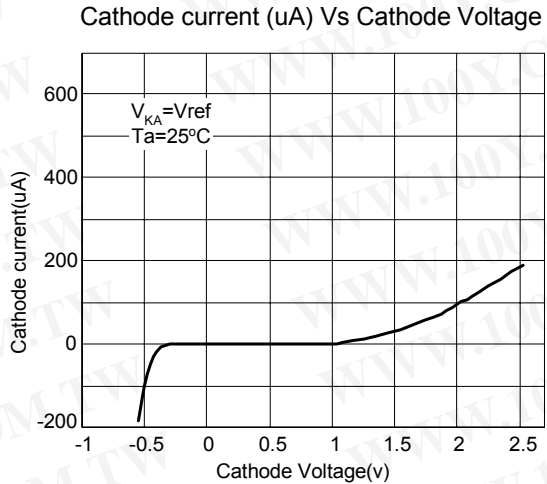
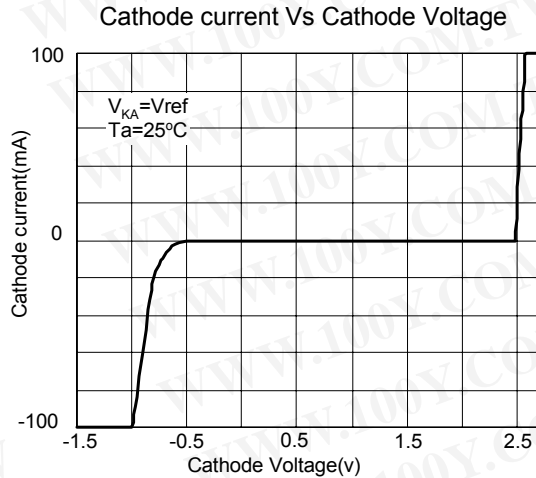

勝特力材料 886-3-5753170
勝特力电子(上海) 86-21-34970699
勝特力电子(深圳) 86-755-83298787
[Http://www.100y.com.tw](http://www.100y.com.tw)

Adjustable Precision Shunt Regulator

Typical Performance Characteristics(Continued)

SMALL-SIGNAL VOLTAGE AMPLIFICATION vs. FREQUENCY

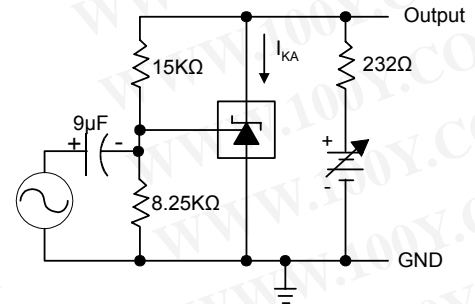
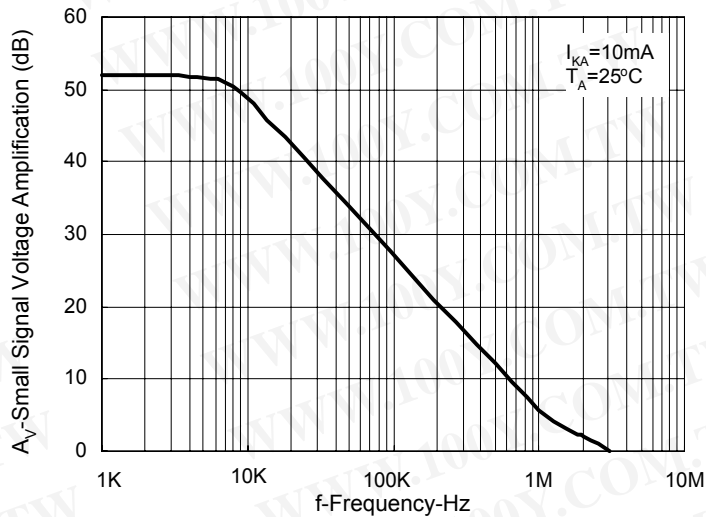

TEST CIRCUIT FOR VOLTAGE AMPLIFICATION

REFERENCE IMPEDANCE vs. FREQUENCY

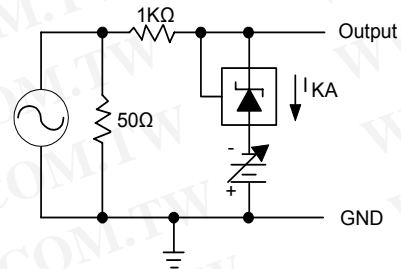
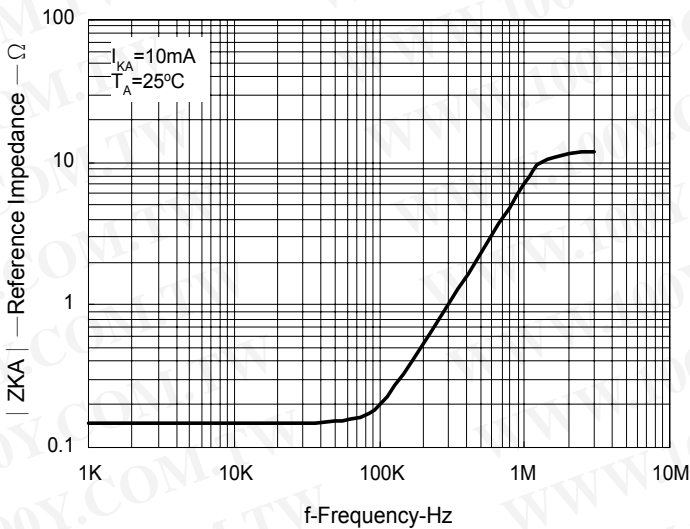

TEST CIRCUIT FOR REFERENCE IMPEDANCE

勝特力材料 886-3-5753170
 勝特力电子(上海) 86-21-34970699
 勝特力电子(深圳) 86-755-83298787
[Http://www.100y.com.tw](http://www.100y.com.tw)



AP431/AP431A

Adjustable Precision Shunt Regulator

PULSE RESPONSE

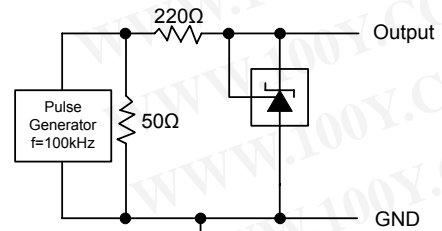
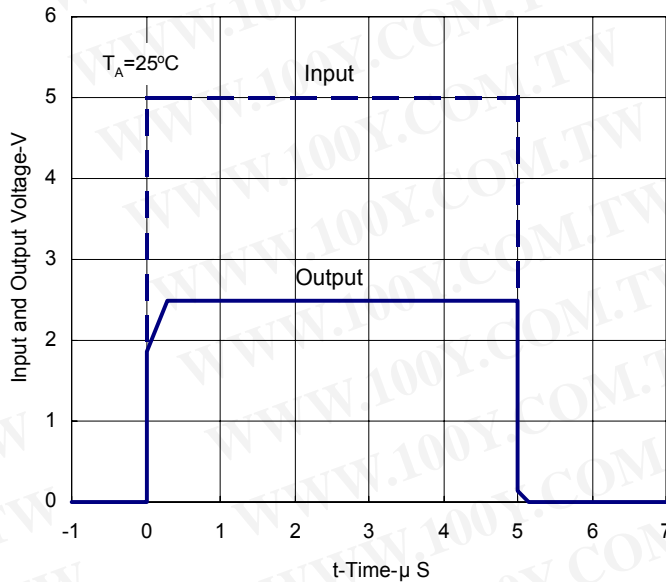

TEST CIRCUIT FOR PULSE RESPONSE

STABILITY BOUNDARY CONDITIONS[†]

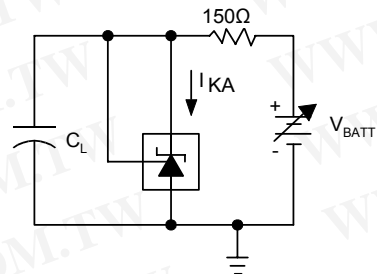
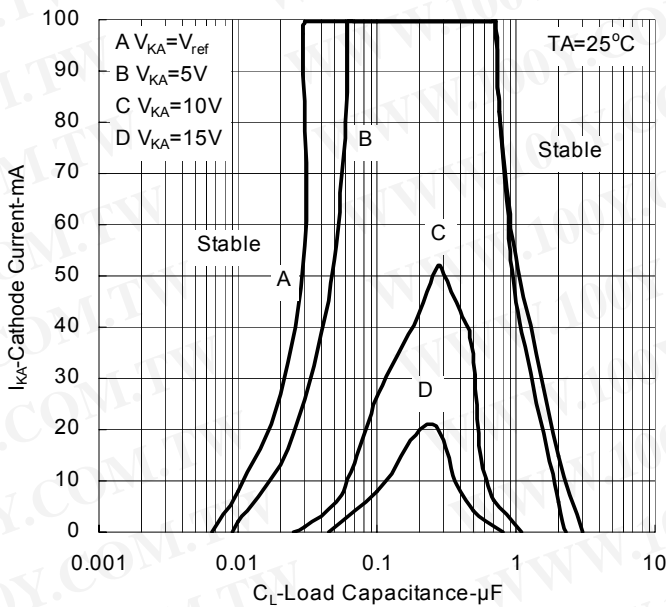

TEST CIRCUIT FOR CURVE A

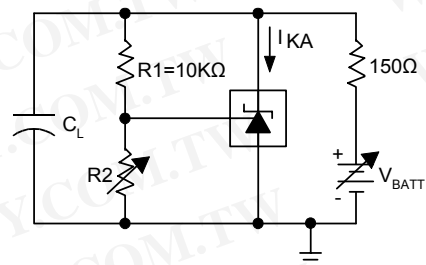

TEST CIRCUIT FOR CURVE B, C, AND D

[†]The areas under the curves represent conditions that may cause the device to oscillate. For curves B, C, and D, R_2 and V_+ were adjusted to establish the initial V_{KA} and I_{KA} conditions with $C_L=0$. V_{BATT} and C_L were then adjusted to determine the ranges of stability.

勝特力材料 886-3-5753170
 勝特力电子(上海) 86-21-34970699
 勝特力电子(深圳) 86-755-83298787
[Http://www.100y.com.tw](http://www.100y.com.tw)

Adjustable Precision Shunt Regulator

Application Examples

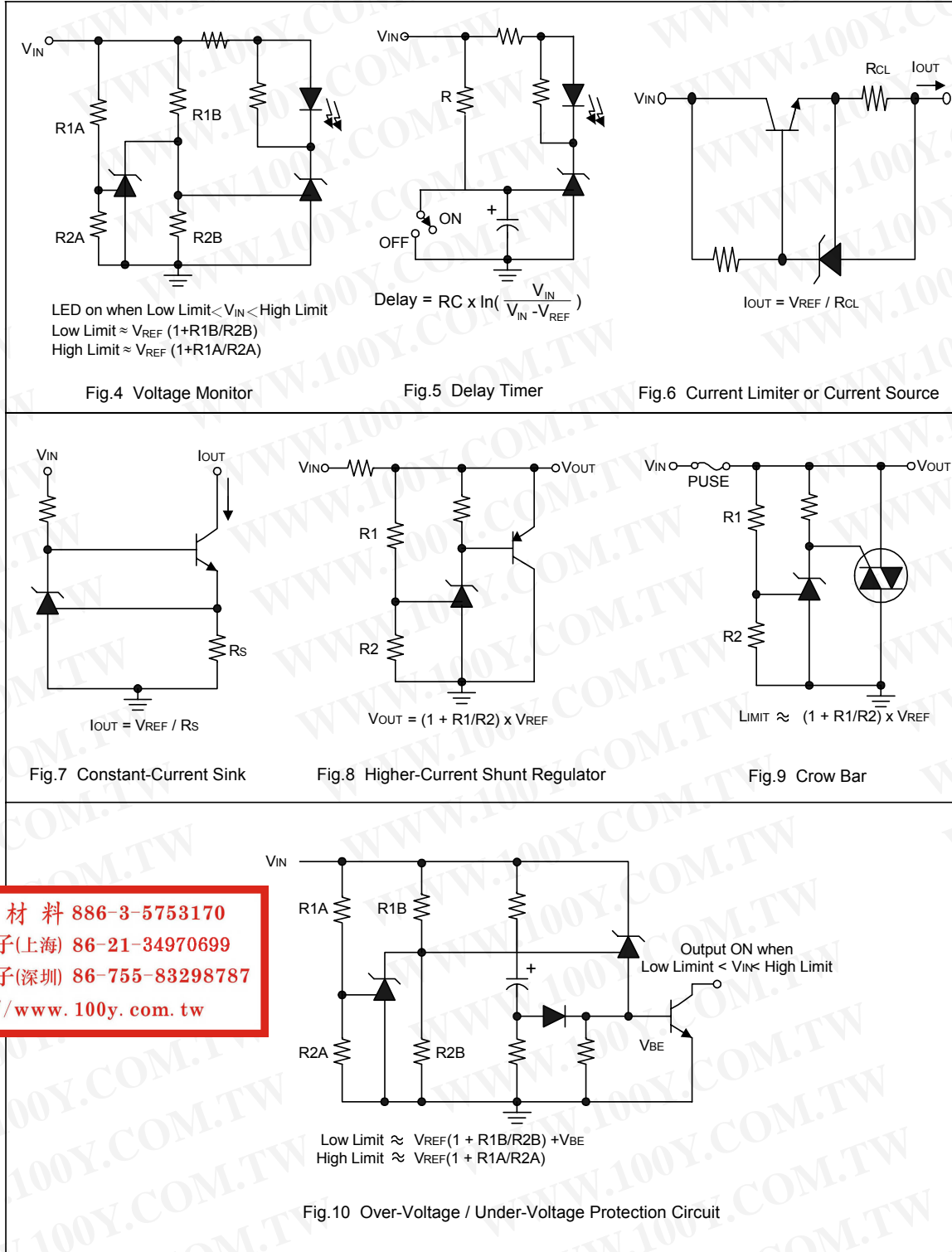

勝特力材料 886-3-5753170
勝特力电子(上海) 86-21-34970699
勝特力电子(深圳) 86-755-83298787
[Http://www.100y.com.tw](http://www.100y.com.tw)



AP431/AP431A

Adjustable Precision Shunt Regulator

■ Package Diagrams

(1) SOT89-3L Package Outline Dimension

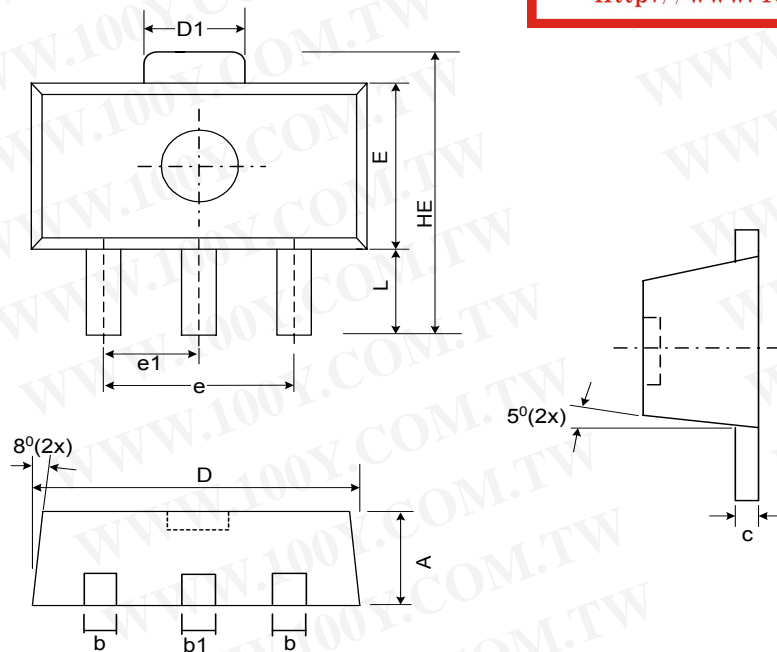

勝特力材料 886-3-5753170
 勝特力电子(上海) 86-21-34970699
 勝特力电子(深圳) 86-755-83298787
[Http://www.100y.com.tw](http://www.100y.com.tw)

Symbol	Dimensions In Millimeters			Dimensions In Inches		
	Min.	Nom.	Max.	Min.	Nom.	Max.
A	1.40	1.50	1.60	0.055	0.059	0.063
b	0.36	0.42	0.48	0.014	0.016	0.018
b1	0.41	0.47	0.53	0.016	0.043	0.051
C	0.35	0.39	0.43	0.014	0.015	0.017
D	4.40	4.50	4.60	0.173	0.177	0.181
D1	1.40	1.60	1.75	0.055	0.062	0.069
e	2.90	3.00	3.10	0.114	0.118	0.122
e1	1.45	1.50	1.55	0.057	0.059	0.061
E	2.40	2.50	2.60	0.094	0.098	0.102
HE	3.94	-	4.25	0.155	-	0.167
L	0.80	-	1.20	0.031	-	0.047



AP431/AP431A

Adjustable Precision Shunt Regulator

(2) TO92-3L Package Outline Dimension

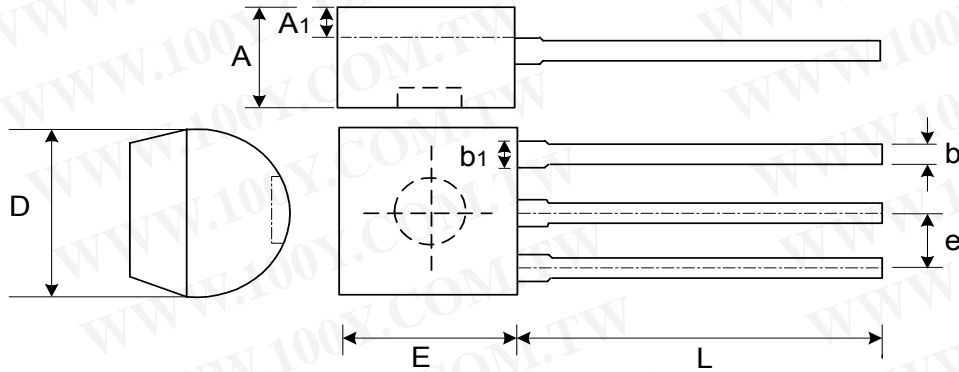

Symbol	Dimensions In Millimeters			Dimensions In Inches		
	Min.	Nom.	Max.	Min.	Nom.	Max.
A	3.302	3.556	3.810	0.130	0.140	0.150
A1	1.016	-	-	0.040	-	-
b	0.330	0.381	0.432	0.013	0.015	0.017
b1	0.406	0.457	0.506	0.016	0.018	0.020
D	4.445	4.572	4.699	0.175	0.180	0.185
E	4.445	4.572	4.699	0.175	0.180	0.185
L	13.00	-	15.500	0.512	-	0.610
e	1.150	1.270	1.390	0.045	0.050	0.055

勝特力材料 886-3-5753170
 勝特力电子(上海) 86-21-34970699
 勝特力电子(深圳) 86-755-83298787
[Http://www.100y.com.tw](http://www.100y.com.tw)



勝特力材料 886-3-5753170
 勝特力电子(上海) 86-21-34970699
 勝特力电子(深圳) 86-755-83298787
 Http://www.100y.com.tw

AP431/AP431A

Adjustable Precision Shunt Regulator

(3) SOT23-5L Package Outline Dimension

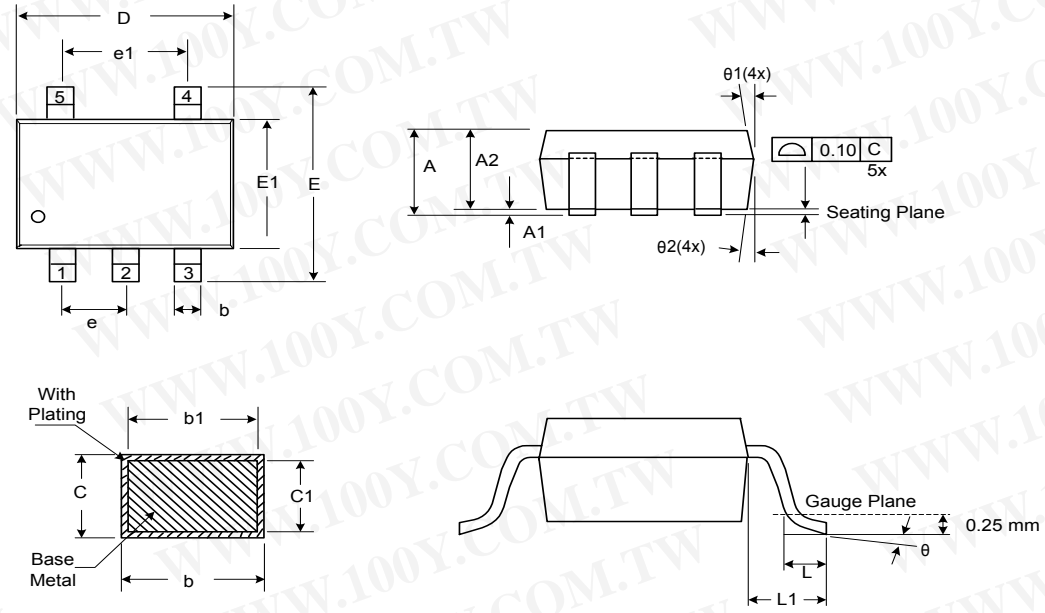

Symbol	Dimensions In Millimeters			Dimensions In Inches		
	Min.	Nom.	Max.	Min.	Nom.	Max.
A	1.05	1.20	1.35	0.041	0.047	0.053
A1	0.05	0.10	0.15	0.002	0.004	0.006
A2	1.00	1.10	1.20	0.039	0.043	0.047
b	0.25	-	0.55	0.010	-	0.022
b1	0.25	0.40	0.45	0.010	0.016	0.018
c	0.08	-	0.20	0.003	-	0.008
c1	0.08	0.11	0.15	0.003	0.004	0.006
D	2.70	2.85	3.00	0.106	0.112	0.118
E	2.60	2.80	3.00	0.102	0.110	0.118
E1	1.50	1.60	1.70	0.059	0.063	0.067
L	0.35	0.45	0.55	0.014	0.018	0.022
L1	0.60 Ref.			0.024 Ref.		
e	0.95 Bsc.			0.037 Bsc.		
e1	1.90 Bsc.			0.075 Bsc.		
theta	0°	5°	10°	0°	5°	10°
theta1	3°	5°	7°	3°	5°	7°
theta2	6°	8°	10°	6°	8°	10°



AP431/AP431A

Adjustable Precision Shunt Regulator

(4) SOT23-3L Package Outline Dimension

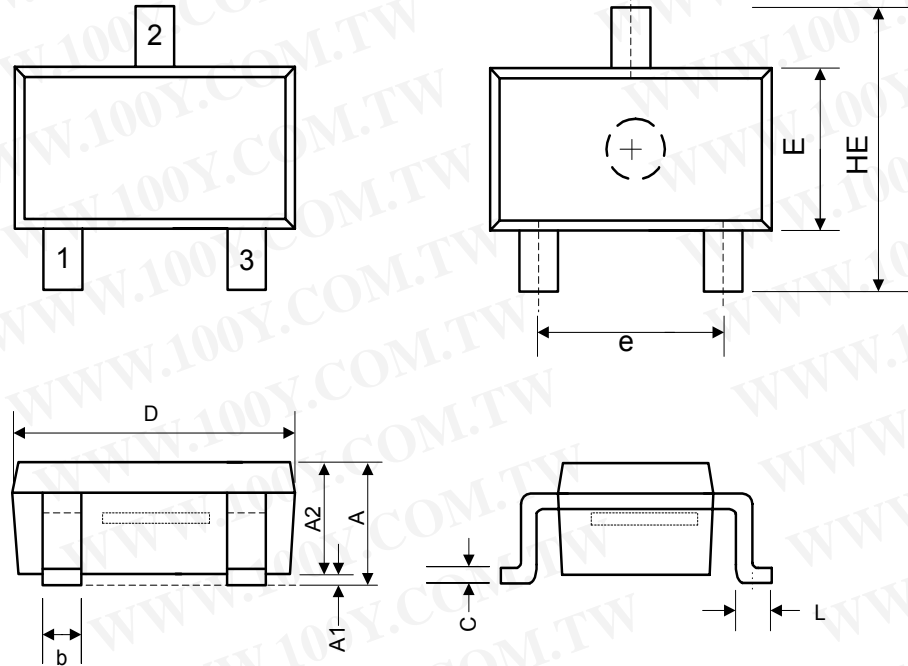

Symbol	Dimensions In Millimeters			Dimensions In Inches		
	Min.	Nom.	Max.	Min.	Nom.	Max.
A	1.00	1.20	1.40	0.039	0.047	0.055
A1	0.00	-	0.10	0.000	-	0.004
A2	1.00	1.15	1.30	0.039	0.045	0.051
b	0.35	-	0.50	0.014	-	0.020
C	0.10	0.175	0.25	0.004	0.007	0.010
D	2.70	2.90	3.10	0.106	0.114	0.122
E	1.40	1.60	1.80	0.055	0.063	0.071
e	1.70	2.00	2.30	0.067	0.079	0.091
HE	2.40	2.70	3.00	0.094	0.106	0.118
L	0.30	-	0.55	0.012	-	0.022

勝特力材料 886-3-5753170
 勝特力电子(上海) 86-21-34970699
 勝特力电子(深圳) 86-755-83298787
[Http://www.100y.com.tw](http://www.100y.com.tw)



AP431/AP431A

Adjustable Precision Shunt Regulator

(5) SOP-8L Package Outline Dimension

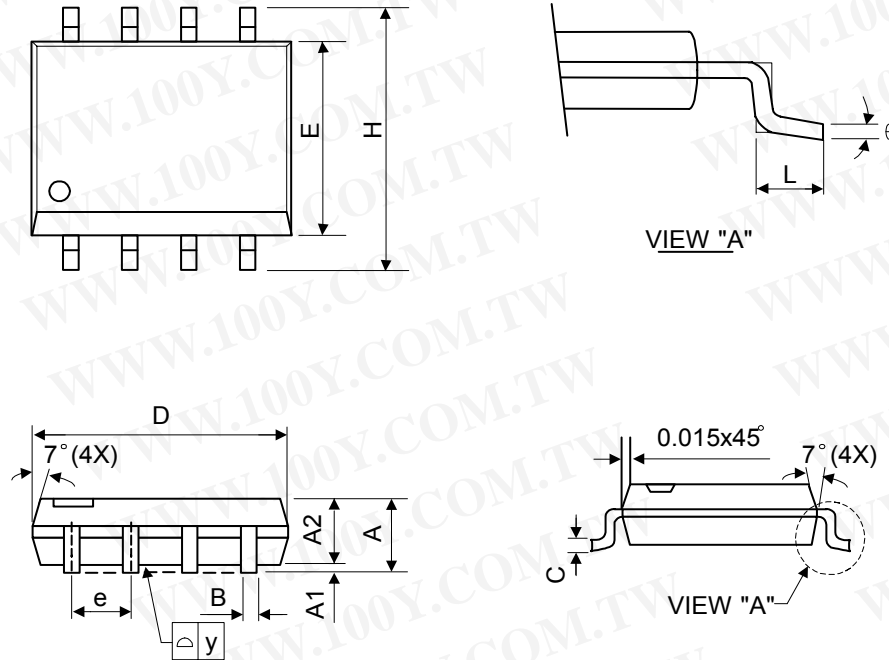

Symbol	Dimensions In Millimeters			Dimensions In Inches		
	Min.	Nom.	Max.	Min.	Nom.	Max.
A	1.40	1.60	1.75	0.055	0.063	0.069
A1	0.10	-	0.25	0.040	-	0.100
A2	1.30	1.45	1.50	0.051	0.057	0.059
B	0.33	0.41	0.51	0.013	0.016	0.020
C	0.19	0.20	0.25	0.0075	0.008	0.010
D	4.80	5.05	5.30	0.189	0.199	0.209
E	3.70	3.90	4.10	0.146	0.154	0.161
e	-	1.27	-	-	0.050	-
H	5.79	5.99	6.20	0.228	0.236	0.244
L	0.38	0.71	1.27	0.015	0.028	0.050
y	-	-	0.10	-	-	0.004
θ	0°	-	8°	0°	-	8°

勝特力材料 886-3-5753170
 勝特力电子(上海) 86-21-34970699
 勝特力电子(深圳) 86-755-83298787
[Http://www.100y.com.tw](http://www.100y.com.tw)



AP431/AP431A

Adjustable Precision Shunt Regulator

■ Taping Information

(1)T092 TAPING

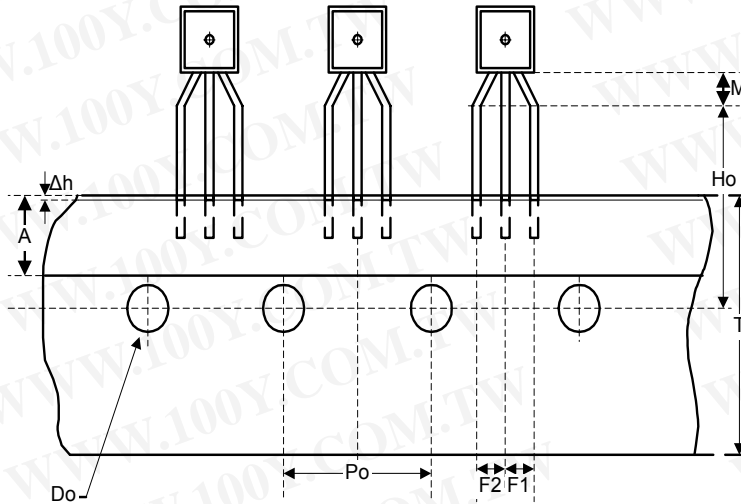

Symbol	Millimeters			Inches		
	Min.	Typ.	Max.	Min.	Typ.	Max.
Po	12.4	12.7	13.0	0.488	0.500	0.512
M	2.0	2.5	3.0	0.079	0.098	0.118
Ho	15.5	16.0	16.5	0.610	0.630	0.650
Do	-	4.0	-	-	0.157	-
A	-	6.0	-	-	0.236	-
Δh	0.0	-	1.0	0.000	-	0.039
T	-	18.0	-	-	0.709	-
F1	2.4	2.5	2.9	0.094	0.098	0.114
F2	2.4	2.5	2.9	0.094	0.098	0.114

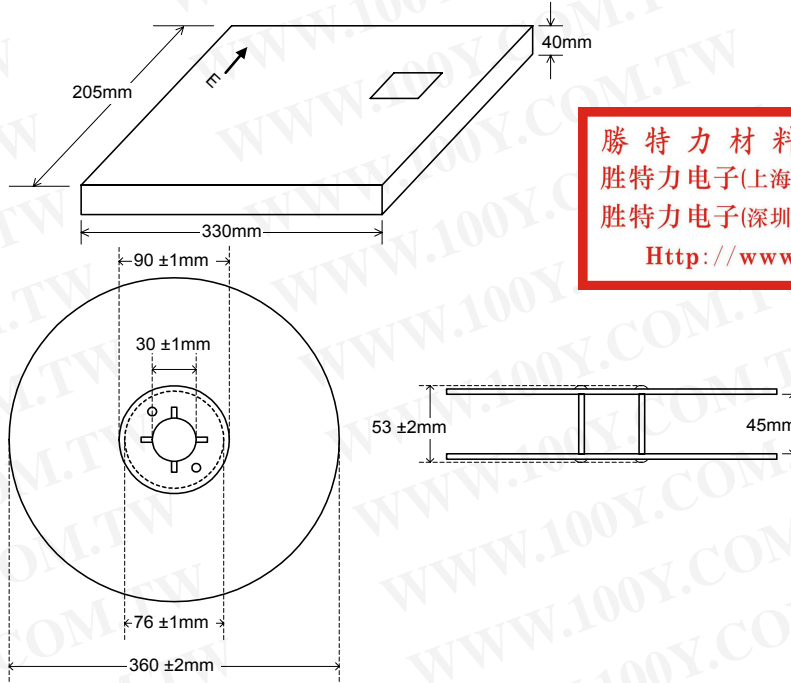

勝特力材料 886-3-5753170
 勝特力电子(上海) 86-21-34970699
 勝特力电子(深圳) 86-755-83298787
[Http://www.100y.com.tw](http://www.100y.com.tw)



AP431/AP431A

Adjustable Precision Shunt Regulator

(2)TO92 TAPING

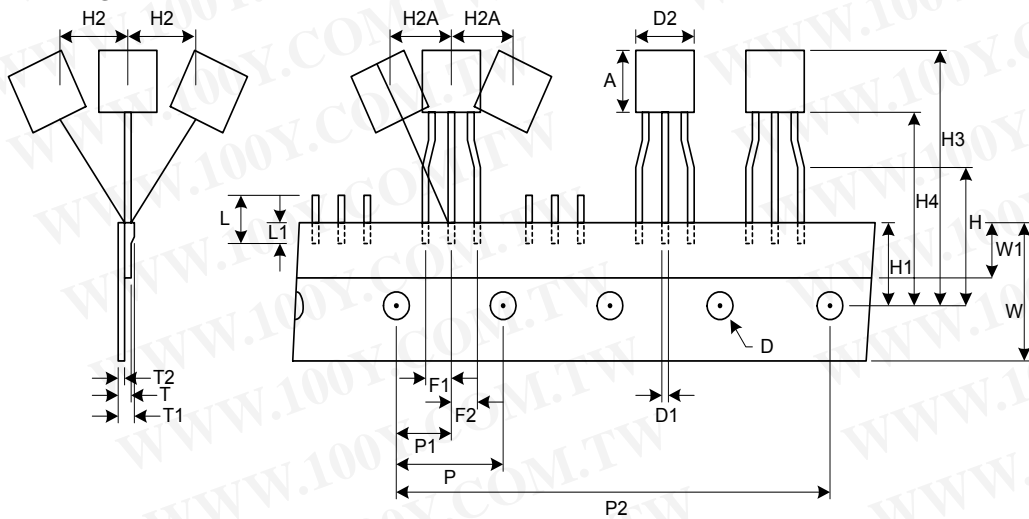

Symbol	Millimeters			Inches		
	Min.	Typ.	Max.	Min.	Typ.	Max.
A	3.18	7.59	12	0.125	0.299	0.472
D	3.8	4	4.2	0.150	0.157	0.165
D1	0.36	0.445	0.53	0.014	0.018	0.021
D2	-	-	9.0	-	-	0.354
F1,F2	2.4	2.5	2.7	0.094	0.098	0.106
F1-F2	-	0.30	-	-	±0.012	-
H	15.5	16	16.5	0.610	0.630	0.650
H1	8.5	9	9.5	0.335	0.354	0.374
H2	-	-	0.5	-	-	0.020
H2A	-	-	0.5	-	-	0.020
H3	-	-	27	-	-	1.063
H4	-	-	20	-	-	0.787
L	-	-	11	-	-	0.433
L1	2.5	-	-	0.098	-	-
P	12.5	12.7	12.9	0.492	0.500	0.508
P1	5.95	6.35	6.75	0.234	0.250	0.266
P2	50.3	50.8	51.3	1.980	2.000	2.020
T	-	-	0.55	-	-	0.022
T1	-	-	1.42	-	-	0.056
T2	0.36	0.52	0.68	0.014	0.020	0.027
W	17.5	18.25	19	0.689	0.719	0.748
W1	5	6	7	0.197	0.236	0.276
----*	253	254	255	9.961	10.000	10.039

----* = every 20 pcs distance.

勝特力材料 886-3-5753170
 勝特力电子(上海) 86-21-34970699
 勝特力电子(深圳) 86-755-83298787
[Http://www.100y.com.tw](http://www.100y.com.tw)

