

DATA SHEET

CHIP RESISTORS
RC1210 (Pb Free)
5%; 1%

勝特力材料 886-3-5753170
勝特力电子(上海) 86-21-34970699
勝特力电子(深圳) 86-755-83298787
[Http://www.100y.com.tw](http://www.100y.com.tw)

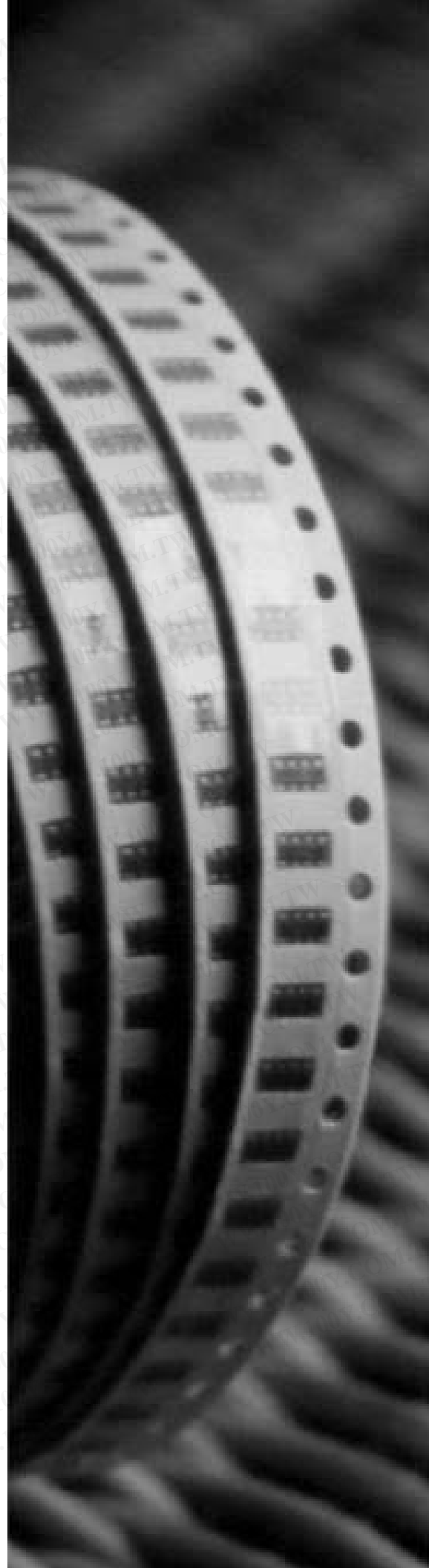

勝特力材料 886-3-5753170
 勝特力电子(上海) 86-21-34970699
 勝特力电子(深圳) 86-755-83298787
[Http://www.100y.com.tw](http://www.100y.com.tw)

SCOPE

This specification describes RC 1210 series chip resistors with lead-free terminations made by thick film process.

ORDERING INFORMATION

Part number is identified by the series, size, tolerance, packing style, temperature coefficient, special type and resistance value.

RC1210 X X X XX XXXX L
 (1) (2) (3) (4) (5) (6)

MARKING

RC1210

(1) TOLERANCE

- F = ±1%
- J = ±5%

(2) PACKAGING TYPE

R = Paper taping reel

(3) TEMPERATURE CHARACTERISTIC OF RESISTANCE

- F = ±100ppm/°C
- G = ±200ppm/°C
- I = ±300ppm/°C
- = Base on spec

(4) SPECIAL TYPE

07 = 7 inch dia. Reel

(5) RESISTANCE VALUE

5R6, 56R, 560R, 5K6, 56K, 22M.

(6) RESISTOR TERMINATIONS

L = Lead free terminations (pure Tin)



Fig. 1 Value=10KΩ

E-24 series: 3 digits

First two digits for significant figure and 3rd digit for number of zeros



Fig. 2 Value=10KΩ

Both E-24 and E-96 series: 4 digits

First three digits for significant figure and 4th digit for number of zeros

CONSTRUCTION

The resistors are constructed out of a high-grade ceramic body. Internal metal electrodes are added at each end and connected by a resistive paste. The composition of the paste is adjusted to give the approximate required resistance and laser cutting of this resistive layer that achieves tolerance trims the value. The resistive layer is covered with a protective coat and printed with the resistance value. Finally, the two external terminations (pure Tin) are added. See fig. 3

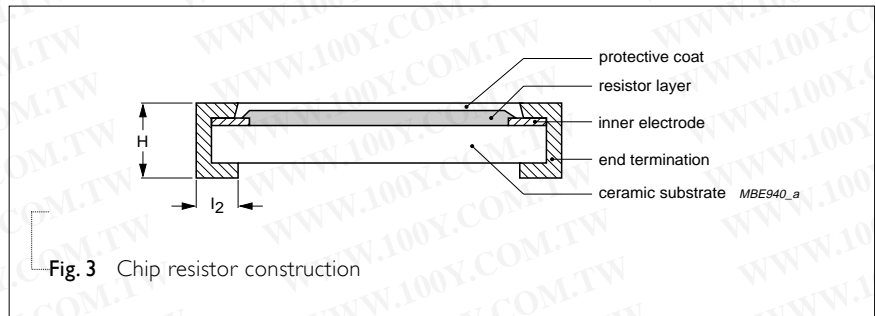

勝特力材料 886-3-5753170
 勝特力电子(上海) 86-21-34970699
 勝特力电子(深圳) 86-755-83298787
[Http://www.100y.com.tw](http://www.100y.com.tw)

DIMENSION

Table I

TYPE	RC1210
L (mm)	3.10±0.10
W (mm)	2.60±0.15
H (mm)	0.50±0.10
l ₁ (mm)	0.45±0.15
l ₂ (mm)	0.50±0.20

For dimension see Table I

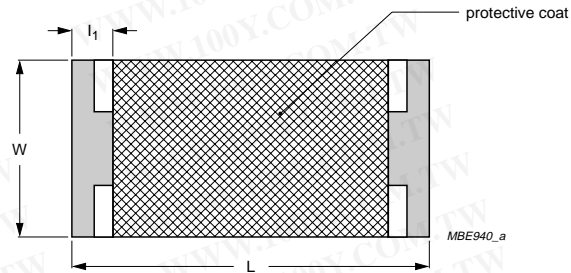

Fig. 4 Chip resistor dimension

POWER RATING

**RATED POWER AT 70°C,
RC1210 1/2W**

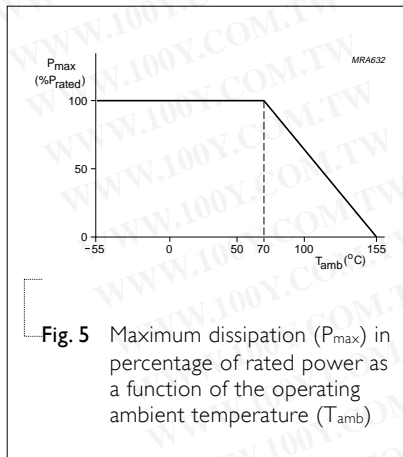

Fig. 5 Maximum dissipation (P_{max}) in percentage of rated power as a function of the operating ambient temperature (T_{amb})

ELECTRICAL CHARACTERISTICS

Table 2

CHARACTERISTICS	RC1210 1/2 W
Operating Temperature Range	-55°C to +155°C
Maximum Working Voltage	200V
Maximum Overload Voltage	400V
Dielectric Withstanding Voltage	500V
Resistance Range	1Ω to 22MΩ (E24)
	1Ω to 10MΩ (E96)
	Zero Ohm Jumper<0.05Ω
Temperature Coefficient	10Ω< R ≤10MΩ ±100ppm/°C
	R≤10Ω; R>10MΩ ±200ppm/°C
Jumper Criteria	Rated Current 2.0A
	Maximum Current 10.0A

RATED VOLTAGE:

The DC or AC (rms) continuous working voltage corresponding to the rated power is determined by the following formula:

$$V = \sqrt{P \times R}$$

Where

V=Continuous rated DC or AC (rms) working voltage (V)

P=Rated power (W)

R=Resistance value (Ω)

勝特力材料 886-3-5753170
 勝特力电子(上海) 86-21-34970699
 勝特力电子(深圳) 86-755-83298787
[Http://www.100y.com.tw](http://www.100y.com.tw)

TAPING REEL

Table 3

DIMENSION	RC1210
Tape Width	8mm
ØA (mm)	180+0/-3
ØB (mm)	60+1/-0
ØC (mm)	13.0±0.2
W (mm)	9.0±0.3
T (mm)	11.4±1

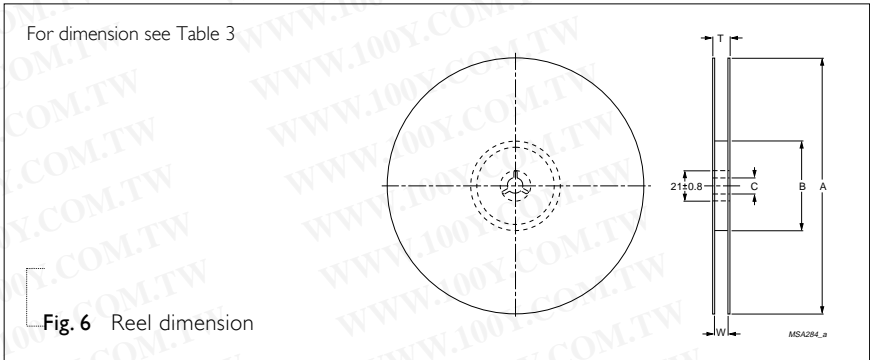

PAPER TAPE SPECIFICATION

Table 4

DIMENSION	RC1210
A (mm)	2.80±0.1
B (mm)	3.5±0.1
W (mm)	8.0±0.2
E (mm)	1.75±0.1
F (mm)	3.5±0.05
P ₀ (mm)	4.0±0.1
P ₁ (mm)	4.0±0.05
P ₂ (mm)	2.0±0.05
ØD ₀ (mm)	1.5+0.1/-0
T (mm)	0.85±0.10

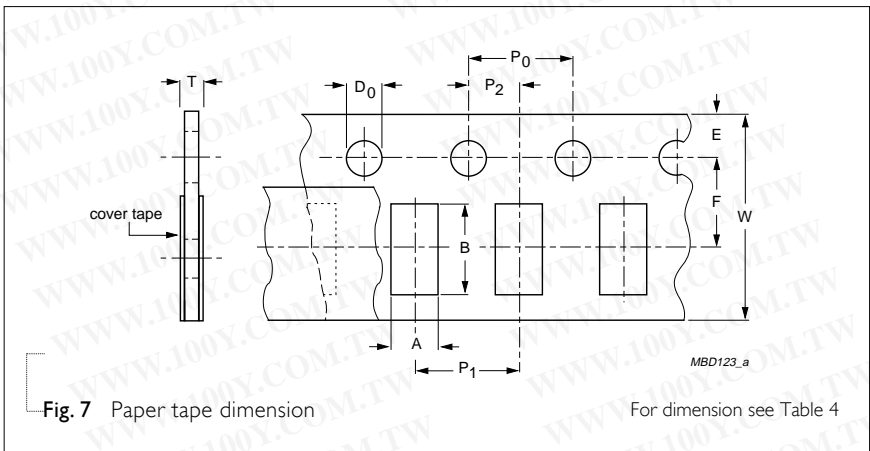

PACKING METHOD

LEADER/TRAILER TAPE SPECIFICATION

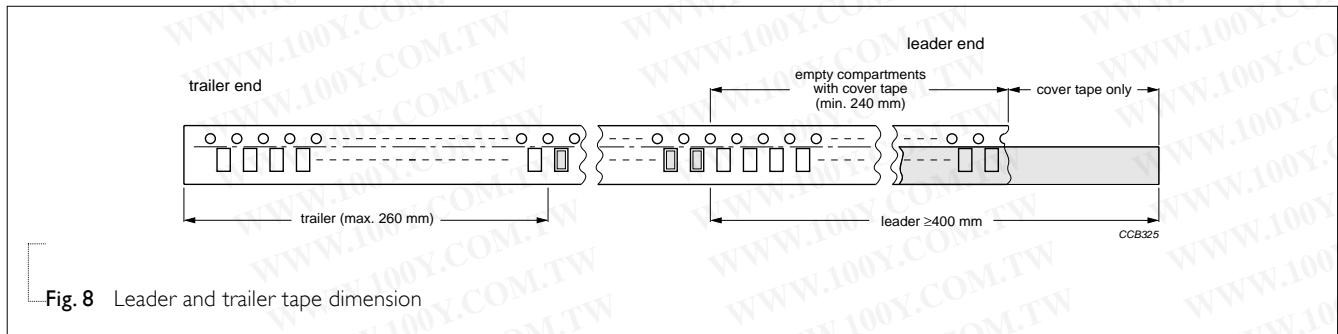

Table 5 Packing style and packaging quantity

PACKING STYLE	REEL DIMENSION	RC1210
Paper Taping Reel (R)	7" (178 mm)	5,000

TYPE	TEST METHOD	Formula	ACCEPTANCE STANDARD				
Temperature Coefficient of Resistance (T.C.R.)	Measure resistance at +25°C or specified room temperature as R ₁ , then measure at -55°C or +155°C respectively as R ₂ . Determine the temperature coefficient of resistance from the following formula:	$T.C.R. = \frac{R_2 - R_1}{R_1(t_2 - t_1)} \times 10^6 \text{ (ppm/}^\circ\text{C)}$ Where t ₁ = +25°C or specified room temperature t ₂ = -55°C or +155°C test temperature R ₁ = resistance at reference temperature in ohms R ₂ = resistance at test temperature in ohms	Refer to table 2				
Thermal Shock	At -55±3°C for 2 minutes and at +155±2°C for 2 minutes as one cycle. After 5 cycles, the specimen shall be stabilized at room temp. Measure the resistance to determine ΔR/R(%) after one more hour.		±(0.5%+0.05Ω) for 1% tol. ±(1%+0.05Ω) for 5% tol.				
Low Temperature Operation	Place the specimen in a test chamber maintained at -65 (+0/-5)°C. After one hour stabilization at this temperature, full rated working voltage shall be applied for 45 (+5/-0) minutes. Have 15 (+5/-0) minutes after remove the voltage, the specimen shall be removed from the chamber and stabilized at room temperature for 24 hrs. Measure the resistance to determine ΔR/R(%).		±(0.5%+0.05Ω) for 1% tol. ±(1.0%+0.05Ω) for 5% tol. No visible damage				
Short Time Overload	Apply 2.5 times of rated voltage but not exceeding the maximum overload voltage for 5 seconds. Have the specimen stabilized at room temperature for 30 minutes minimum. Measure the resistance to determine ΔR/R(%).		±(1.0%+0.05Ω) for 1% tol. ±(2.0%+0.05Ω) for 5% tol. No visible damage				
Insulation Resistance	Place the specimen in the jig and apply a rated continues overload voltage (R.C.O.V) for one minute as shown. Measure the insulation resistance.	<table border="1"> <tr> <td>Type (DC)</td> <td>RC1210</td> </tr> <tr> <td>Voltage</td> <td>400V</td> </tr> </table>	Type (DC)	RC1210	Voltage	400V	≥10,000MΩ
Type (DC)	RC1210						
Voltage	400V						
Dielectric Withstand Voltage	Place the specimen in the jig and apply a specified value continuous overload voltage as shown for one minute.	<table border="1"> <tr> <td>Type (AC)</td> <td>RC1210</td> </tr> <tr> <td>Voltage</td> <td>500Vrms</td> </tr> </table>	Type (AC)	RC1210	Voltage	500Vrms	Breakdown voltage > specification and without open/short
Type (AC)	RC1210						
Voltage	500Vrms						
Resistance To Soldering Heat	Immerse the specimen in the solder pot at 260±5°C. for 10±1 seconds. Have the specimen stabilized at room temperature for 30 minutes minimum. Measure the resistance to determine ΔR/R(%).		±(0.5%+0.05Ω) for 1% tol. ±(1.0%+0.05Ω) for 5% tol. No visible damage				

勝特力材料 886-3-5753170
勝特力电子(上海) 86-21-34970699
勝特力电子(深圳) 86-755-83298787
[Http://www.100y.com.tw](http://www.100y.com.tw)

TYPE	TEST METHOD	ACCEPTANCE STANDARD
Moisture Resistance	Place the specimen in the test chamber and subject to 42 damp heat cycles. Each one of which consists of the steps 1 to 7 as figure 10. The total length of test is 1,000 hours. Have the specimen stabilized at room temperature for 24 hours after testing. Measure the resistance to determine $\Delta R/R(\%)$.	$\pm(0.5\%+0.05\Omega)$ for 1% tol. $\pm(2.0\%+0.05\Omega)$ for 5% tol. No visible damage
Life	Place the specimen in the oven at $70\pm 2^{\circ}\text{C}$. Apply the rated voltage to the specimen at the 1.5 hours on and 0.5 hour off cycle. The total length of test is 1,000 hours. Have the specimen stabilized at room temperature for one hour minimum after testing. Measure the $\Delta R/R(\%)$.	$\pm(1\%+0.05\Omega)$ for 1% tol. $\pm(3\%+0.05\Omega)$ for 5% tol. No visible damage
Solderability	Immerse the specimen in the solder pot at $245\pm 5^{\circ}\text{C}$ for 2 sec.	At least 95% solder coverage on the termination

Bending Strength Mount the specimen on a test board as shown in the figure 9. Slowly apply the force till the board is bent for 5 ± 1 sec.
Measure the $\Delta R/R(\%)$ at this position.

Type **RC1210**
Bent Distance (d) 2mm

$\pm(1.0\%+0.05\Omega)$ for 1% tol.
 $\pm(1.0\%+0.05\Omega)$ for 5% tol.
No visible damage

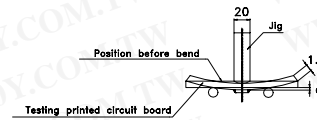
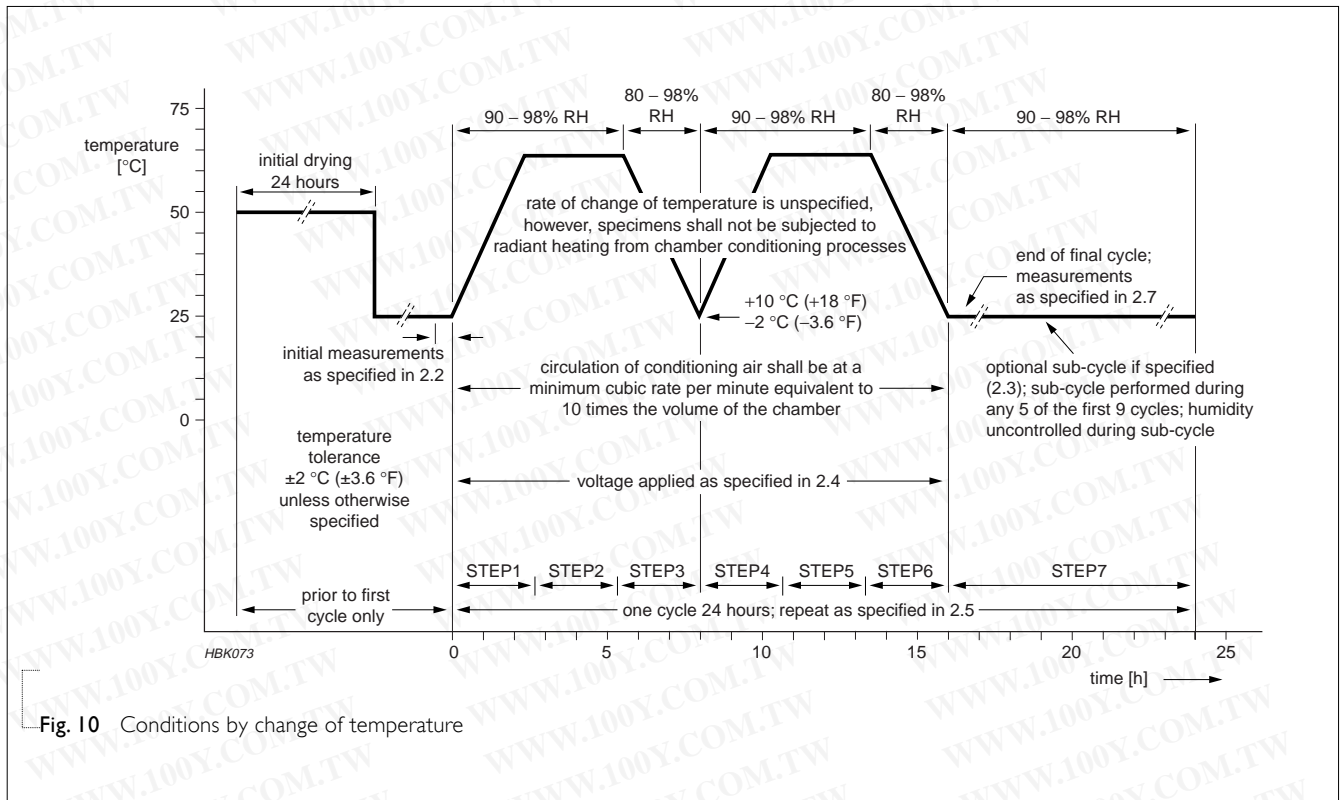

Fig. 9 Principle of the bending test

勝特力材料 886-3-5753170
 勝特力电子(上海) 86-21-34970699
 勝特力电子(深圳) 86-755-83298787
[Http://www.100y.com.tw](http://www.100y.com.tw)



勝特力材料 886-3-5753170
勝特力电子(上海) 86-21-34970699
勝特力电子(深圳) 86-755-83298787
[Http://www.100y.com.tw](http://www.100y.com.tw)