

# International IOR Rectifier

## 300U(R) SERIES

### STANDARD RECOVERY DIODES

### Stud Version

#### Features

- Alloy diode
- Popular series for rough service
- Stud cathode and stud anode version

#### Typical Applications

- Welders
- Power supplies
- Motor controls
- Battery chargers
- General industrial current rectification

#### Major Ratings and Characteristics

Parameters	300U	Units
$I_{F(AV)}$	300	A
@ $T_c$	150	°C
$I_{FSM}$		
@ 50Hz	6550	A
@ 60Hz	6850	A
$I^2t$		
@ 50Hz	214	KA <sup>2</sup> s
@ 60Hz	195	KA <sup>2</sup> s
$V_{RRM}$ range	100 to 600	V
$T_J$	-65 to 200	°C

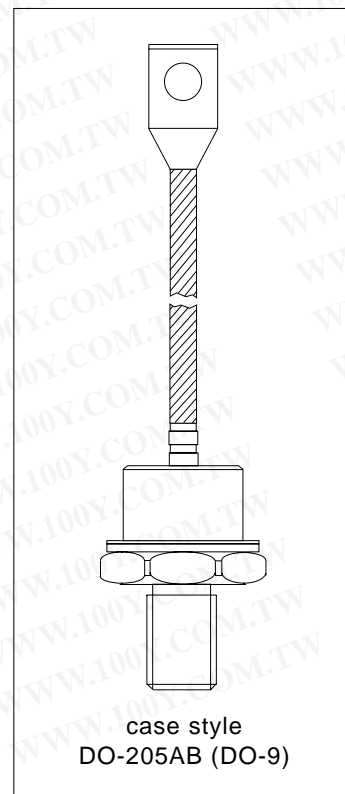

### 300U(R) Series

Bulletin I2039 rev. C 03/03

International  
 Rectifier

#### ELECTRICAL SPECIFICATIONS

##### Voltage Ratings

Type number	Voltage Code	$V_{RRM}$ , maximum repetitive peak reverse voltage V	$V_{RSM}$ , maximum non-repetitive peak rev. voltage V	$I_{RRM}$ max. $T_J = 175^\circ\text{C}$ mA
300U	10	100	200	40
	20	200	300	
	30	300	400	
	40	400	500	
	60	600	700	

##### Forward Conduction

Parameter	300U	Units	Conditions		
$I_{F(AV)}$ Max. average forward current @ Case temperature	300	A	180° conduction, half sine wave		
	130	°C			
$I_{FSM}$ Max. peak, one-cycle forward, non-repetitive surge current	6550	A	t = 10ms	No voltage	Sinusoidal half wave, Initial $T_J = T_J$ max.
	6850		t = 8.3ms	reapplied	
	5500		t = 10ms	100% $V_{RRM}$	
	5750		t = 8.3ms	reapplied	
$I^2t$ Maximum $I^2t$ for fusing	214	KA <sup>2</sup> s	t = 10ms	No voltage	
	195		t = 8.3ms	reapplied	
	151		t = 10ms	100% $V_{RRM}$	
	138		t = 8.3ms	reapplied	
$I^2\sqrt{t}$ Maximum $I^2\sqrt{t}$ for fusing	2140	KA <sup>2</sup> √s	t = 0.1 to 10ms, no voltage reapplied		
$V_{F(TO)}$ Max. value of threshold voltage	0.610	V	$T_J = 200^\circ\text{C}$		
$r_f$ Max. value of forward slope resistance	0.751	mΩ			
$V_{FM}$ Max. peak forward voltage	1.40	V	$I_{peak} = 942\text{A}, T_J = 25^\circ\text{C}$		

##### Thermal and Mechanical Specifications

Parameter	300U(R)	Units	Conditions
$T_J$ Max. junction operating temperature range	-65 to 200	°C	
$T_{stg}$ Max. storage temperature range	-65 to 200		
$R_{thJC}$ Max. thermal resistance, junction to case	0.18	K/W	DC operation
$R_{thCS}$ Max. thermal resistance, case to heatsink	0.08		Mounting surface, smooth, flat and greased
T Max. allowed mounting torque +0 -20%	37	Nm	Not lubricated threads
	28		Lubricated threads
wt Approximate weight	250	g	
Case style	DO-205AB (DO-9)**		JEDEC (See Outline Table)

\*\* 302U-A uses IR case style B-26

$\Delta R_{thJC}$  Conduction

(The following table shows the increment of thermal resistance  $R_{thJC}$  when devices operate at different conduction angles than DC)

Conduction angle	Sinusoidal conduction	Rectangular conduction	Units	Conditions
180°	0.020	0.015	K/W	$T_J = T_J \text{ max.}$
120°	0.024	0.025		
90°	0.031	0.034		
60°	0.045	0.047		
30°	0.077	0.077		

Ordering Information Table

**Device Code**

300	U	R	060	A
①	②	③	④	⑤

- 1** - 300 = Standard 300U device  
302 = 300U Top Threaded version
- 2** - U = Essential Part Number
- 3** - R = Stud Reverse Polarity (Anode to Stud)  
None = Stud Normal Polarity (Cathode to Stud)
- 4** - Voltage code: Code x 10 =  $V_{RRM}$  (See Voltage Ratings table)
- 5** - A = Essential Part Number

NOTE: For Metric Device M16 x 1.5 Contact Factory

**300U(R) Series**

Bulletin I2039 rev. C 03/03

International  
**IR** Rectifier

Outline Table

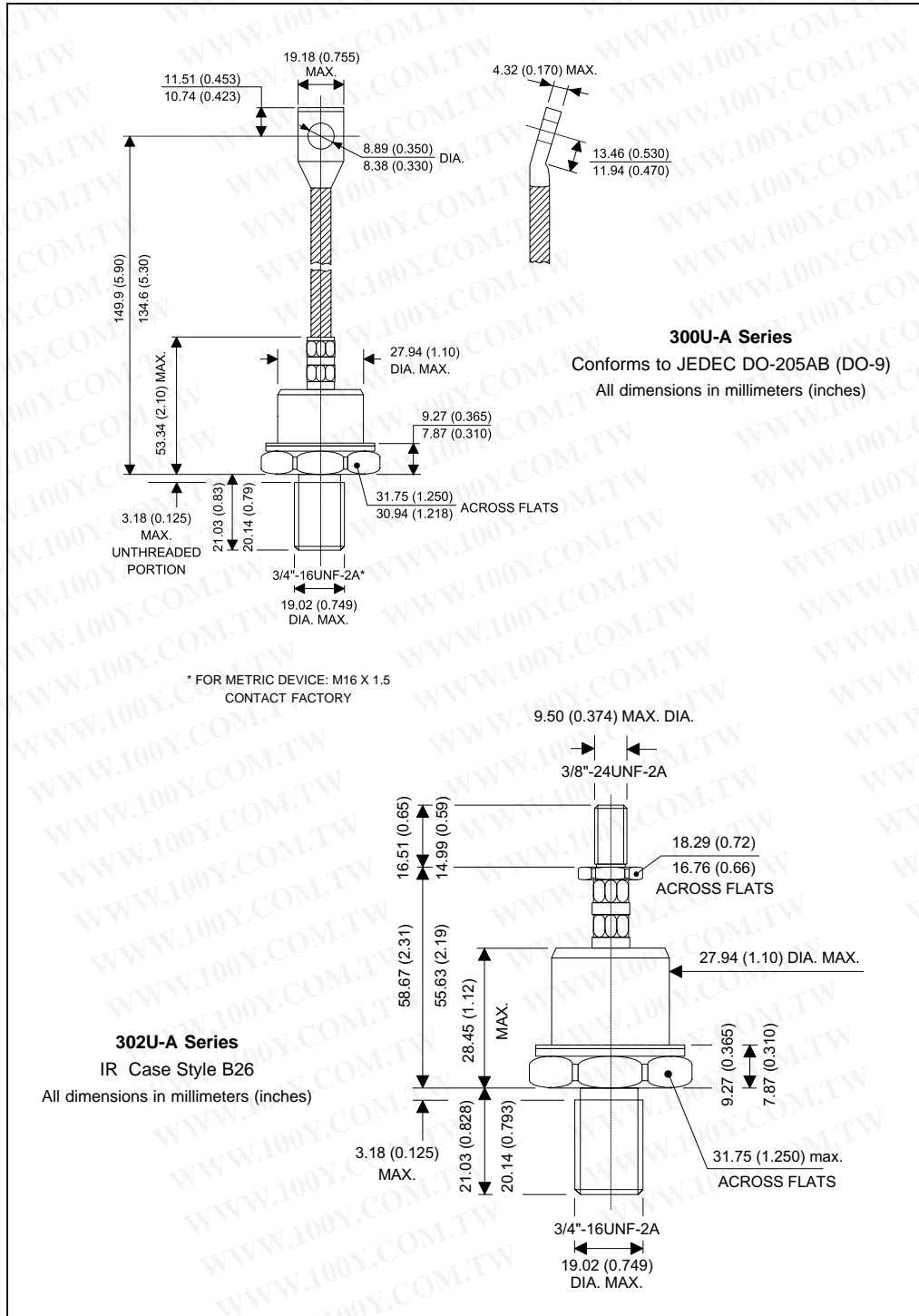

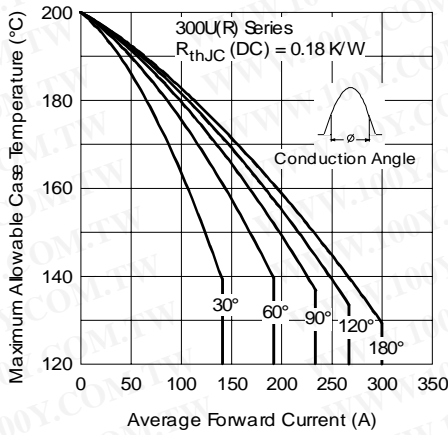

Fig. 1 - Current Ratings Characteristics

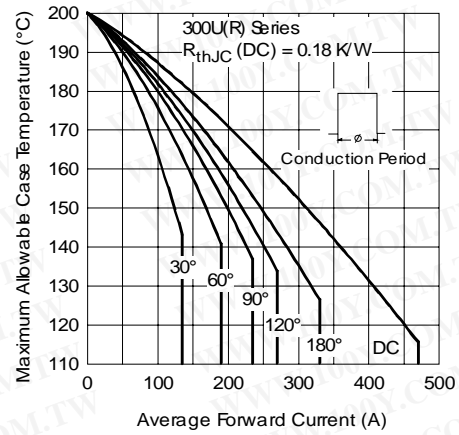

Fig. 2 - Current Ratings Characteristics

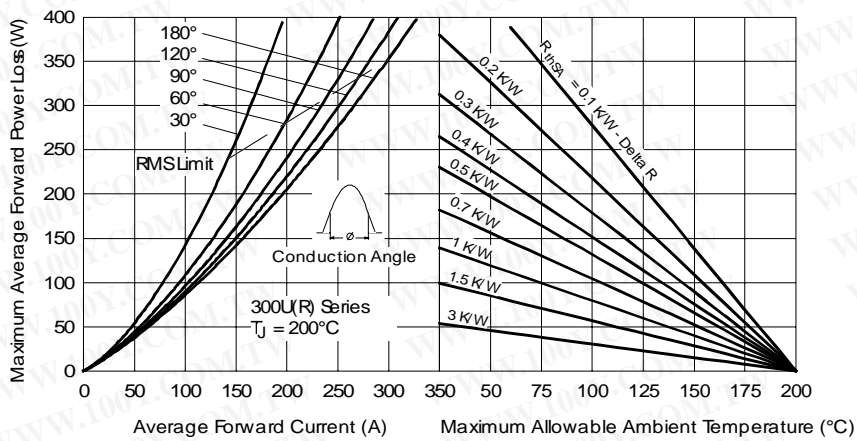

Fig. 3 - Forward Power Loss Characteristics

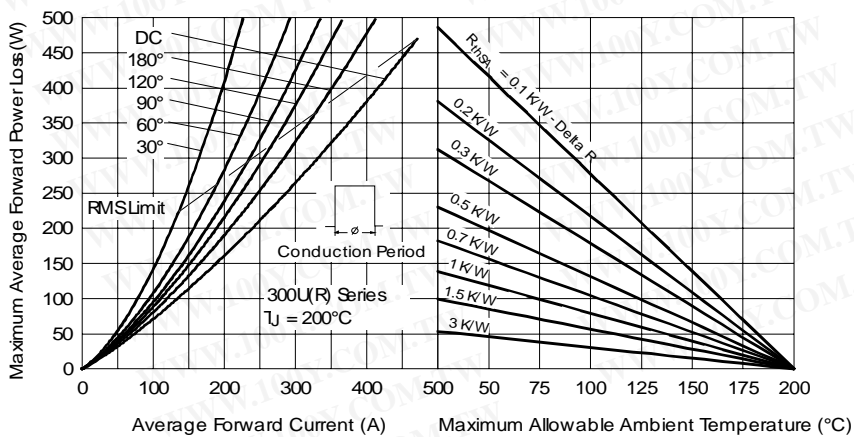

Fig. 4 - Forward Power Loss Characteristics

### 300U(R) Series

Bulletin I2039 rev. C 03/03

International  
**IR** Rectifier

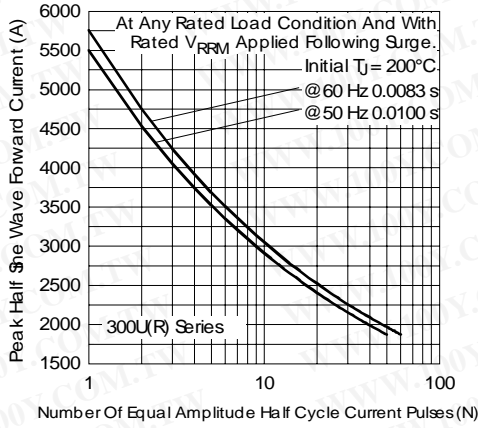

Fig. 5 - Maximum Non-Repetitive Surge Current

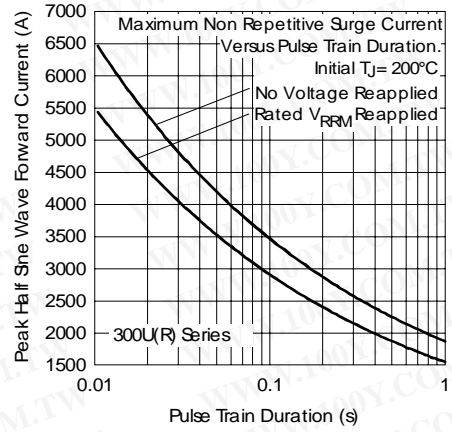

Fig. 6 - Maximum Non-Repetitive Surge Current

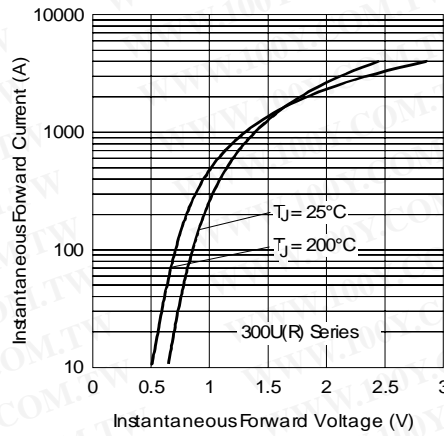

Fig. 7 - Forward Voltage Drop Characteristics

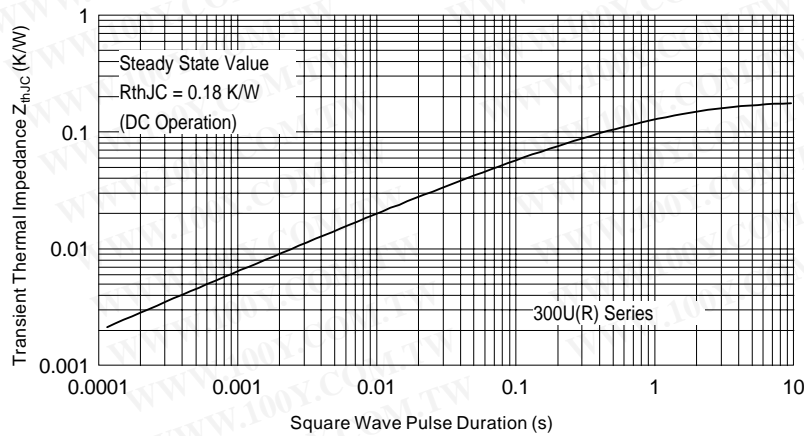

Fig. 8 - Thermal Impedance  $Z_{thjC}$  Characteristic