

勝特力材料 886-3-5753170  
勝特力电子(上海) 86-21-34970699  
勝特力电子(深圳) 86-755-83298787  
[Http://www.100y.com.tw](http://www.100y.com.tw)

# DATA SHEET

THIN FILM CHIP RESISTORS

High precision - high stability

RT series

0.05% TO 1%, TC 10 TO 50

sizes 0402/0603/0805/1206/

1210/2010/2512

RoHS compliant



**SCOPE**

This specification describes RT0402 to RT2512 high precision - high stability chip resistors with lead-free terminations made by thin film process.

**APPLICATIONS**

- Converters
- Printer equipment
- Server board
- Telecom
- Consumer

**FEATURES**

- Halogen Free Epoxy
- RoHS compliant
  - Products with lead free terminations meet RoHS requirements
  - Pb-glass contained in electrodes, resistor element and glass are exempted by RoHS
- Reducing environmentally hazardous wastes
- High component and equipment reliability
- Saving of PCB space
- None forbidden-materials used in products/production

**ORDERING INFORMATION - GLOBAL PART NUMBER & I2NC**

Both part numbers are identified by the series, size, tolerance, packing type, temperature coefficient, taping reel and resistance value.

**YAGEO BRAND ordering code**

**GLOBAL PART NUMBER (PREFERRED)**

**RT XXXX F X X XX XXXX L**  
 (1) (2) (3) (4) (5) (6) (7)

**(1) SIZE**

0402 / 0603 / 0805 / 1206 / 1210 / 2010 / 2512

**(2) TOLERANCE**

W = ±0.05%  
 B = ±0.1%  
 C = ±0.25%  
 D = ±0.5%  
 F = ±1%

**勝特力材料 886-3-5753170**  
**胜特力电子(上海) 86-21-34970699**  
**胜特力电子(深圳) 86-755-83298787**  
[Http://www.100y.com.tw](http://www.100y.com.tw)

**(3) PACKAGING TYPE**

R = Paper/PE taping reel      K = Embossed taping reel

**(4) TEMPERATURE COEFFICIENT OF RESISTANCE**

B = 10 ppm/°C      C = 15 ppm/°C      D = 25 ppm/°C      E = 50 ppm/°C

**(5) TAPING REEL**

07 = 7 inch dia. Reel      10 = 10 inch dia. Reel      13 = 13 inch dia. Reel

**(6) RESISTANCE VALUE**

There are 2~4 digits indicated the resistor value. Letter R/K/M is decimal point, no need to mention the last zero after R/K/M, e.g. 1K2, not 1K20.

Detailed resistance rules show in table of "Resistance rule of global part number".

**(7) DEFAULT CODE**

Letter L is system default code for order only (Note)

Resistance code rule	Example
XRXX (1 to 9.76 Ω)	1R = 1 Ω 1R5 = 1.5 Ω 9R76 = 9.76 Ω
XXRX (10 to 97.6 Ω)	10R = 10 Ω 97R6 = 97.6 Ω
XXXX (100 to 976 Ω)	100R = 100 Ω
XKXX (1 to 9.76 KΩ)	1K = 1,000 Ω 9K76 = 9760 Ω
XMXX (1 to 9.76 MΩ)	1M = 1,000,000 Ω 9M76 = 9,760,000 Ω

**ORDERING EXAMPLE**

The ordering code of a RT0603 chip resistor, TC 50 value 56 Ω with ±0.5% tolerance, supplied in 7-inch tape reel is: RT0603DRE0756RL.

**NOTE**

1. All our RSMD products meet RoHS compliant and Halogen Free. "LFP" of the internal 2D reel label mentions "Lead Free Process"
2. On customized label, "LFP" or specific symbol can be printed

**PHYCOMP BRAND ordering codes**

Both GLOBAL PART NUMBER (preferred) and I2NC (traditional) codes are acceptable to order Phycomp brand products. For matching traditional types with size codes, please refer to “Comparison table of traditional types and sizes”.

**GLOBAL PART NUMBER (PREFERRED)**

For detailed information of GLOBAL PART NUMBER and ordering example, please refer to page 2.

**I2NC CODE**

2390 (1)	X (2)	XX (3)	X (4)	XXXX (5)	L (6)
START WITH <sup>(1)</sup>	TCR <sup>(2)</sup> (ppm/°C)	PACKING CODE BY SIZE (inch) <sup>(3)</sup>	TOL. <sup>(4)</sup> (%)	RESISTANCE RANGE	DEFAULT CODE (NOTE)
2390	8 = ±10 7 = ±15 6 = ±25 4 = ±50	0402: 07 = 7" reel 27 = 10" reel 47 = 13" reel 0603: 04 = 7" reel 24 = 10" reel 44 = 13" reel 0805: 01 = 7" reel 21 = 10" reel 41 = 13" reel 1206: 11 = 7" reel 31 = 10" reel 51 = 13" reel 1210: 12 = 7" reel 32 = 10" reel 52 = 13" reel 2010: 15 = 7" reel 2512: 18 = 7" reel	7 = ±1 6 = ±0.5 5 = ±0.25 4 = ±0.1 3 = ±0.05	The remaining 4 digits represent the resistance value with the last digit indicating the multiplier as shown in the table of “Last digit of I2NC”.	Letter L is system default code for order only
				0402: 10Ω ≤ R < 121KΩ 0603: 5.1 Ω ≤ R ≤ 681 KΩ 0805: 5.1Ω ≤ R ≤ 1.5 MΩ 1206: 5.1Ω ≤ R ≤ 1.5 MΩ 1210: 5.1Ω ≤ R ≤ 1.5 MΩ 2010: 10Ω ≤ R ≤ 1 MΩ 2512: 10Ω ≤ R ≤ 1 MΩ	

Comparison table of traditional types and sizes

TF (1)	X (2)	X (3)	X (4)
START WITH	SIZE CODE	TCR (ppm/°C)	TOL (%)
TF	3 = 0402 2 = 0603 1 = 0805 0 = 1206 5 = 1210 7 = 2010 6 = 2512	4 = ±10 3 = ±15 1 = ±25 2 = ±50	0 = ±1 1 = ±0.5 2 = ±0.25 3 = ±0.1 4 = ±0.05

**Example:**

TF321 = RT0402, TC50, ±0.5% tolerance

Resistance decade <sup>(3)</sup>	Last digit
1 to 9.76 Ω	8
10 to 97.6 Ω	9
100 to 976 Ω	1
1 to 9.76 kΩ	2
10 to 97.6 kΩ	3
100 to 976 kΩ	4
1 to 9.76 MΩ	5
10 to 97.6 MΩ	6

Example: 1 Ω = 1008 or 108  
33 kΩ = 3303 or 333  
10 MΩ = 1006 or 106

**Exceptions to above packing code definitions:**

- 0805 TC50 with 1%, supplied in 13" reel, the packing code is 02.
- 0603 TC50 with 1%, supplied in 13" reel, the packing code is 03.
- 2512 TC15, in 7" reel, the packing code is 35.
- 2010 TC15, in 7" reel, the packing code is 31.

**ORDERING EXAMPLE**

The ordering code of a TF221 resistor, TC50, value 56 Ω, with ±0.5% tolerance, supplied in tape of 5,000 units per reel is: 239040465609L or RT0603DRE0756RL.

**NOTE**

- All our RSMD products meet RoHS compliant and Halogen Free. "LFP" of the internal 2D reel label mentions "Lead Free Process"
- On customized label, "LFP" or specific symbol can be printed

**勝特力材料 886-3-5753170**  
**勝特力电子(上海) 86-21-34970699**  
**勝特力电子(深圳) 86-755-83298787**  
[Http://www.100y.com.tw](http://www.100y.com.tw)

勝特力材料 886-3-5753170  
 勝特力电子(上海) 86-21-34970699  
 勝特力电子(深圳) 86-755-83298787  
[Http://www.100y.com.tw](http://www.100y.com.tw)

**MARKING**

RT0805 / RT1206 / RT1210 / RT2010 / RT2512



Fig. 1 Value = 10 kΩ

Either resistance in E-24 or E-96: 4 digits  
 First three digits for significant figure and 4th digit for number of zeros

RT0603



Fig. 2 Value = 12 kΩ

E-24 series: 3 digits  
 First two digits for significant figure and 3rd digit for number of zeros



Fig. 3 Value = 12.4 kΩ

E-96 series: 3 digits for 0603±1% EIA-96 marking method

RT0402 / RESISTANCE VALUE IS NOT IN E-24 / E96 SERIES

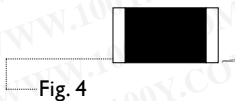

Fig. 4

No marking

For further marking information, please see special data sheet “Chip resistors marking”.

**CONSTRUCTION**

The resistors are constructed out of a high-grade ceramic body. Internal metal electrodes are added at each end and connected by a resistive layer. The resistive layer is adjusted to give the approximate required resistance and laser cutting of this resistive layer that achieves tolerance trims the value. The resistive layer is covered with a protective coat and printed with the resistance value. Finally, the two external terminations (matte tin) are added. See fig. 5.

**OUTLINES**

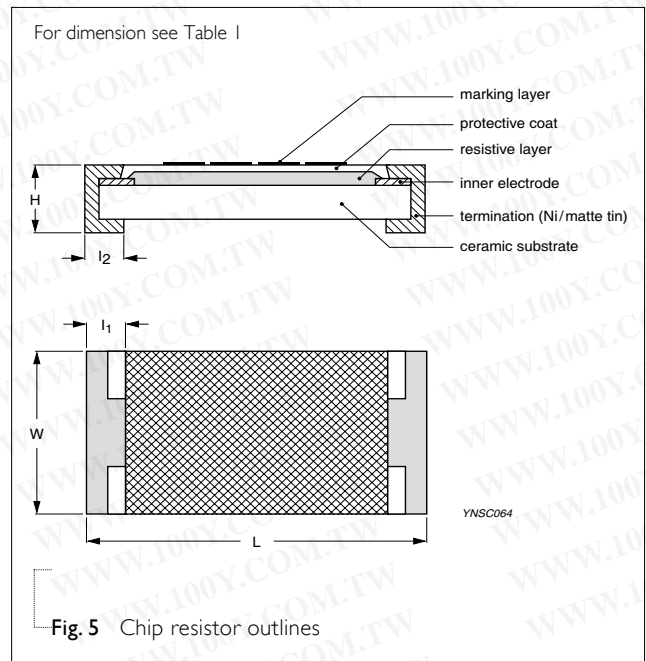

Fig. 5 Chip resistor outlines

**DIMENSION**

Table I For outlines see fig. 5

TYPE	L (mm)	W (mm)	H (mm)	l <sub>1</sub> (mm)	l <sub>2</sub> (mm)
RT0402	1.00 ±0.10	0.50 ±0.05	0.30 ±0.05	0.20 ±0.10	0.25 ±0.10
RT0603	1.60 ±0.10	0.80 ±0.10	0.45 ±0.10	0.25 ±0.15	0.25 ±0.15
RT0805	2.00 ±0.10	1.25 ±0.10	0.50 ±0.10	0.35 ±0.20	0.35 ±0.20
RT1206	3.10 ±0.10	1.60 ±0.10	0.55 ±0.10	0.45 ±0.20	0.40 ±0.20
RT1210	3.10 ±0.10	2.60 ±0.15	0.55 ±0.10	0.50 ±0.20	0.50 ±0.20
RT2010	5.00 ±0.10	2.50 ±0.15	0.55 ±0.10	0.60 ±0.20	0.50 ±0.20
RT2512	6.35 ±0.10	3.20 ±0.15	0.55 ±0.10	0.60 ±0.20	0.50 ±0.20

勝特力材料 886-3-5753170  
 勝特力电子(上海) 86-21-34970699  
 勝特力电子(深圳) 86-755-83298787  
[Http://www.100y.com.tw](http://www.100y.com.tw)

**ELECTRICAL CHARACTERISTICS**

Table 2

TYPE	Operating Temperature Range	Power Rating	Max. Work Vol. (1)	Max. Overload Vol.	Dielectric Withstand Vol.	T.C.R. (ppm/°C)	Resistance Range (E-24/E-96 series) <sup>(2)</sup> & Tolerance					
							±0.05%	±0.1%	±0.25%	±0.5%	±1.0%	
RT0402	-55 °C to +125 °C	1/16W	50V	100V	75V	±50	---	10~121k	10~121k	10~121k	10~121k	
							±25	---	10~121k	10~121k	10~121k	---
							±15	---	10~100k	10~100k	---	---
							±10	---	10~100k	10~100k	---	---
							±50	---	10~681k	5.1~681k	5.1~681k	5.1~681k
RT0603	-55 °C to +125 °C	1/10W	75V	150V	100V	±50	---	10~681k	10~681k	10~681k	---	
							±25	1k~47k	10~681k	10~681k	10~681k	---
							±15	1k~47k	10~100k	10~100k	---	---
							±10	1k~47k	10~100k	10~100k	---	---
							±50	---	10~1.5M	5.1~1.5M	5.1~1.5M	5.1~1.5M
RT0805	-55 °C to +125 °C	1/8W	150V	300V	200V	±50	---	10~1.5M	10~1.5M	10~1.5M	---	
							±25	100~100k	10~1.5M	10~1.5M	10~1.5M	---
							±15	100~100k	10~100k	10~100k	---	---
							±10	100~100k	10~100k	10~100k	---	---
							±50	---	10~1.5M	5.1~1.5M	5.1~1.5M	5.1~1.5M
RT1206	-55 °C to +125 °C	1/4W	200V	400V	300V	±50	---	10~1.5M	10~1.5M	10~1.5M	---	
							±25	100~100k	10~1.5M	10~1.5M	10~1.5M	---
							±15	100~100k	10~100k	10~100k	---	---
							±10	100~100k	10~100k	10~100k	---	---
							±50	---	10~1M	5.1~1M	5.1~1M	5.1~1M
RT1210	-55 °C to +125 °C	1/4W	200V	400V	400V	±50	---	10~1M	10~1M	10~1M	10~1M	
							±25	100~100k	10~1M	10~1M	10~1M	---
							±15	100~100k	10~100k	10~100k	---	---
							±10	100~100k	10~100k	10~100k	---	---
							±50	---	10~1M	10~1M	10~1M	10~1M
RT2010	-55 °C to +125 °C	1/2W	200V	400V	400V	±50	---	10~1M	10~1M	10~1M	10~1M	
							±25	100~100k	10~1M	10~1M	10~1M	---
							±15	100~100k	10~100k	10~100k	---	---
							±10	100~100k	10~100k	10~100k	---	---
							±50	---	10~1M	10~1M	10~1M	10~1M
RT2512	-55 °C to +125 °C	3/4W	200V	400V	400V	±50	---	10~1M	10~1M	10~1M	10~1M	
							±25	100~100k	10~1M	10~1M	10~1M	---
							±15	100~100k	10~100k	10~100k	---	---
							±10	100~100k	10~100k	10~100k	---	---
							±50	---	10~1M	10~1M	10~1M	10~1M

**NOTE**

1. The maximum working voltage that may be continuously applied to the resistor element, see "IEC publication 60115-8"
2. Value of E-192 series is on request

**FOOTPRINT AND SOLDERING PROFILES**

For recommended footprint and soldering profiles, please see the special data sheet “Chip resistors mounting”.

**PACKING STYLE AND PACKAGING QUANTITY**

Table 3 Packing style and packaging quantity

PACKING STYLE	REEL DIMENSION	RT0402	RT0603	RT0805	RT1206	RT1210	RT2010	RT2512
Paper/PE taping reel (R)	7" (178 mm)	10,000	5,000	5,000	5,000	5,000	---	---
	10" (254 mm)	20,000	10,000	10,000	10,000	10,000	---	---
	13" (330 mm)	50,000	20,000	20,000	20,000	20,000	---	---
Embossed taping reel (K)	7" (178 mm)	---	---	---	---	---	4,000	4,000

**NOTE**

I. For Paper/Embossed tape and reel specification/dimensions, please see the special data sheet “Chip resistors packing”

**FUNCTIONAL DESCRIPTION**

**POWER RATING**

Each type rated power at 70°C:  
 RT0402=1/16 W, RT0603=1/10 W, RT0805=1/8 W,  
 RT1206=1/4 W, RT1210=1/4 W, RT2010=1/2 W,  
 RT2512=3/4 W.

**RATED VOLTAGE**

The DC or AC (rms) continuous working voltage corresponding to the rated power is determined by the following formula:

$$V = \sqrt{P \times R}$$

or max. working voltage whichever is less

Where

V=Continuous rated DC or AC (rms) working voltage (V)

P=Rated power (W)

R=Resistance value (Ω)

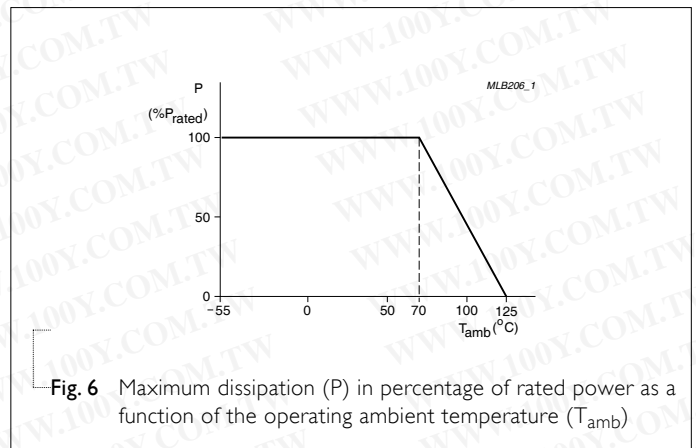

Fig. 6 Maximum dissipation (P) in percentage of rated power as a function of the operating ambient temperature (T<sub>amb</sub>)

**勝特力材料 886-3-5753170**  
**勝特力电子(上海) 86-21-34970699**  
**勝特力电子(深圳) 86-755-83298787**  
**Http://www.100y.com.tw**

**TESTS AND REQUIREMENTS**

Table 4 Test condition, procedure and requirements

TEST	TEST METHOD	PROCEDURE	REQUIREMENTS
Temperature Coefficient of Resistance (T.C.R.)	IEC 60115-1 4.8	At +25/-55 °C and +25/+125 °C  Formula: $T.C.R = \frac{R_2 - R_1}{R_1(t_2 - t_1)} \times 10^6 \text{ (ppm/°C)}$ Where t <sub>1</sub> = +25 °C or specified room temperature t <sub>2</sub> = -55 °C or +125 °C test temperature R <sub>1</sub> = resistance at reference temperature in ohms R <sub>2</sub> = resistance at test temperature in ohms	Refer to table 2
Life/Endurance	IEC 60115-1 4.25.1	At 70±5 °C for 1,000 hours, RCWV applied for 1.5 hours on, 0.5 hour off, still air required	±(0.5%+0.05 Ω)
High Temperature Exposure/Endurance at Upper Category Temperature	IEC 60068-2-2	1,000 hours at 155±5 °C, unpowered	±(0.5%+0.05 Ω)
Moisture Resistance	MIL-STD-202G Method-106G	Each temperature / humidity cycle is defined at 8 hours, 3 cycles / 24 hours for 10d. with 25 °C / 65 °C 95% R.H, without steps 7a & 7b, unpowered  Parts mounted on test-boards, without condensation on parts  Measurement at 24±2 hours after test conclusion	±(0.5%+0.05 Ω)
Thermal Shock	MIL-STD-202G Method-107G	-55/+125 °C  Number of cycles required is 300. Devices unmounted  Maximum transfer time is 20 seconds. Dwell time is 15 minutes. Air – Air	±(0.5%+0.05 Ω) for 10 KΩ to 10 MΩ ±(0.5%+0.05 Ω) for others
Humidity (steady state)	IEC 60115-1 4.37	Steady state for 1000 hours at 40 °C / 95% R.H. RCWV applied for 1.5 hours on and 0.5 hour off	±(0.5%+0.05 Ω)

**勝特力材料 886-3-5753170**  
**勝特力电子(上海) 86-21-34970699**  
**勝特力电子(深圳) 86-755-83298787**  
**Http://www.100y.com.tw**

TEST	TEST METHOD	PROCEDURE	REQUIREMENTS
Short Time Overload	IEC60115-1 4.13	2.5 times of rated voltage or maximum overload voltage whichever is less for 5 sec at room temperature	±(0.5%+0.05 Ω) No visible damage
Board Flex/ Bending	IEC 60068-2-21	Chips mounted on a 90mm glass epoxy resin PCB (FR4) Bending: see table 6 for each size Bending time: 60±5 seconds	±(0.25%+0.05 Ω) No visible damage
Low Temperature Operation	IEC 60068-2-1	The resistor shall be subjected to a DC rated voltage for 1.5 h-on, 0.5 h-off, at -55±3 °C This constitutes shall be repeated for 96 hours However the applied voltage shall not exceed the maximum operating voltage	±(0.5%+0.05 Ω) No visible damage
Insulation Resistance	IEC 60115-1 4.6	Rated continuous overload voltage (RCOV) for 1 minute Details see below table 5	≥10 GΩ
Dielectric Withstand Voltage	IEC 60115-1 4.7	Maximum voltage (V <sub>ms</sub> ) applied for 1 minute Details see below table 5	No breakdown or flashover
Solderability - Wetting	IPC/JEDEC J-STD-002B test B	Electrical Test not required Magnification 50X SMD conditions: 1 <sup>st</sup> step: method B, aging 4 hours at 155°C dry heat 2 <sup>nd</sup> step: leadfree solder bath at 245±3°C Dipping time: 3±0.5 seconds	Well tinned (≥95% covered) No visible damage
- Leaching	IPC/JEDEC J-STD-002B test D	Leadfree solder, 260 °C, 30 seconds immersion time	No visible damage
- Resistance to Soldering Heat	IEC 60068-2-58	Condition B, no pre-heat of samples. Leadfree solder, 260 °C, 10 seconds immersion time Procedure 2 for SMD: devices fluxed and cleaned with isopropanol	±(0.5%+0.05 Ω) No visible damage

**勝特力材料 886-3-5753170**  
**勝特力电子(上海) 86-21-34970699**  
**勝特力电子(深圳) 86-755-83298787**  
**Http://www.100y.com.tw**

Table 5 Criteria of rated continued working voltage and overload voltage

TYPE	RT0402	RT0603	RT0805	RT1206	RT1210	RT2010	RT2512
Voltage (DC/unit: V); (AC/ unit: V <sub>rms</sub> )	100	100	300	500	500	500	500

Table 6 Bending for sizes 0402 to 2512

TYPE	RT0402	RT0603	RT0805	RT1206	RT1210	RT2010	RT2512
Specification (mm)	5	3	3	2	2	2	2

**勝特力材料 886-3-5753170**  
**勝特力电子(上海) 86-21-34970699**  
**勝特力电子(深圳) 86-755-83298787**  
[Http://www.100y.com.tw](http://www.100y.com.tw)

**REVISION HISTORY**

REVISION	DATE	CHANGE NOTIFICATION	DESCRIPTION
Version 4	Oct 21, 2009	-	<ul style="list-style-type: none"> <li>- Test Items and methods updated</li> <li>- Test requirements upgraded</li> </ul>
Version 3	Jul 11, 2008	-	<ul style="list-style-type: none"> <li>- Change to dual brand datasheet that describe RT0402 to RT2512 with RoHS compliant</li> <li>- Description of "Halogen Free Epoxy" added</li> <li>- Define global part number</li> <li>- Modify electrical characteristic</li> </ul>
Version 2	Dec 26, 2005	-	<ul style="list-style-type: none"> <li>- New datasheet for thin film high precision - high stability chip resistors sizes of 0201/0402/0603/0805/1206/1210/2010/2512, 1%, 0.5%, 0.25%, 0.1%, 0.05%, TC25/50 with lead-free terminations</li> <li>- Replace the 0402 to 1210 parts of pdf files: TFx10_1_1, TFx11_5_2, TFx12_25_2, TFx13_1_3, TFx14_05_1, TFx20_1_2, TFx21_5_2, TFx22_25_2, TFx23_1_2, TFx24_05_1, and combine into a document.</li> <li>- Test method and procedure updated</li> <li>- PE tape added (paper tape will be replaced by PE tape)</li> </ul>

*“Yageo reserves all the rights for revising the content of this datasheet without further notification, as long as the products itself are unchanged. Any product change will be announced by PCN.”*