

DATA SHEET

GENERAL PURPOSE CHIP RESISTORS

RC1210
5%, 1%
RoHS compliant

勝特力材料 886-3-5753170
勝特力电子(上海) 86-21-34970699
勝特力电子(深圳) 86-755-83298787
[Http://www.100y.com.tw](http://www.100y.com.tw)



SCOPE

This specification describes RC1210 series chip resistors with lead-free terminations made by thick film process.

APPLICATIONS

- All general purpose application

FEATURES

- Halogen Free Epoxy
- RoHS compliant
 - Products with lead free terminations meet RoHS requirements
 - Pb-glass contained in electrodes, resistor element and glass are exempted by RoHS
- Reducing environmentally hazardous wastes
- High component and equipment reliability
- Saving of PCB space
- None forbidden-materials used in products/production

ORDERING INFORMATION - GLOBAL PART NUMBER & I2NC

Both part numbers are identified by the series, size, tolerance, packing type, temperature coefficient, taping reel and resistance value.

YAGEO BRAND ordering code

GLOBAL PART NUMBER (PREFERRED)

RC1210 X R - XX XXXX L
 (1) (2) (3) (4) (5) (6)

(1) TOLERANCE

F = ±1%
 J = ±5% (for Jumper ordering, use code of J)

(2) PACKAGING TYPE

R = Paper taping reel

(3) TEMPERATURE COEFFICIENT OF RESISTANCE

-- = Base on spec

(4) TAPING REEL

07 = 7 inch dia. Reel
 13 = 13 inch dia. Reel

(5) RESISTANCE VALUE

There are 2~4 digits indicated the resistor value. Letter R/K/M is decimal point, no need to mention the last zero after R/K/M, e.g. 1K2, not 1K20.
 Detailed resistance rules show in table of "Resistance rule of global part number".

(6) DEFAULT CODE

Letter L is system default code for order only (Note)

Resistance rule of global part number

Resistance code rule	Example
0R	0R = Jumper
XRXX (1 to 9.76 Ω)	1R = 1 Ω 1R5 = 1.5 Ω 9R76 = 9.76 Ω
XXRX (10 to 97.6 Ω)	10R = 10 Ω 97R6 = 97.6 Ω
XXXR (100 to 976 Ω)	100R = 100 Ω
XKXX (1 to 9.76 KΩ)	1K = 1,000 Ω 9K76 = 9760 Ω
XMXX (1 to 9.76 MΩ)	1M = 1,000,000 Ω 9M76 = 9,760,000 Ω

ORDERING EXAMPLE

The ordering code of a RC1210 chip resistor, value 56 Ω with ±1% tolerance, supplied in 7-inch tape reel is: RC1210FR-0756RL.

NOTE

1. All our RSMD products meet RoHS compliant and Halogen Free. "LFP" of the internal 2D reel label mentions "Lead Free Process"
2. On customized label, "LFP" or specific symbol can be printed

勝特力材料 886-3-5753170
 勝特力电子(上海) 86-21-34970699
 勝特力电子(深圳) 86-755-83298787
[Http://www.100y.com.tw](http://www.100y.com.tw)

PHYCOMP BRAND ordering codes

Both GLOBAL PART NUMBER (preferred) and I2NC (traditional) codes are acceptable to order Phycomp brand products.

GLOBAL PART NUMBER (PREFERRED)

For detailed information of GLOBAL PART NUMBER and ordering example, please refer to page 2.

I2NC CODE

2390 (1)	XXX (2)	XXXXX (3)	L (4)	EMBOSSED TAPE ON REEL (units) (2)	
TYPE/ START I210 IN (1)	TOL. (%)	RESISTANCE RANGE		5,000	20,000
PRCI01 2390	±5%	1 to 22 MΩ		735 70xxx	735 71xxx
PRCI02 2390	±1%	1 to 10 MΩ		735 3xxxx	735 5xxxx
Jumper 2390	-	0 Ω		735 90001	-

Last digit of I2NC Resistance decade (3)	Last digit
0.01 to 0.0976 Ω	0
0.1 to 0.976 Ω	7
1 to 9.76 Ω	8
10 to 97.6 Ω	9
100 to 976 Ω	1
1 to 9.76 KΩ	2
10 to 97.6 KΩ	3
100 to 976 KΩ	4
1 to 9.76 MΩ	5
10 to 97.6 MΩ	6

- (1) The resistors have a 12-digit ordering code starting with 2390.
- (2) The subsequent 4 or 5 digits indicate the resistor tolerance and packaging.
- (3) The remaining 4 or 3 digits represent the resistance value with the last digit indicating the multiplier as shown in the table of "Last digit of I2NC".
- (4) Letter L is system default code for order only (Note)

Example:

0.02 Ω	=	0200 or 200
0.3 Ω	=	3007 or 307
1 Ω	=	1008 or 108
33 KΩ	=	3303 or 333
10 MΩ	=	1006 or 106

ORDERING EXAMPLE

The ordering code of a PRCI02 resistor, value 56 Ω with ±1% tolerance, supplied in tape of 5,000 units per reel is: 239073535609L or RC1210FR-0756RL.

NOTE

- 1. All our RSMD products meet RoHS compliant and Halogen Free. "LFP" of the internal 2D reel label mentions "Lead Free Process"
- 2. On customized label, "LFP" or specific symbol can be printed

勝特力材料 886-3-5753170
勝特力电子(上海) 86-21-34970699
勝特力电子(深圳) 86-755-83298787
[Http://www.100y.com.tw](http://www.100y.com.tw)

MARKING

RC1210



E-24 series: 3 digits
First two digits for significant figure and 3rd digit for number of zeros

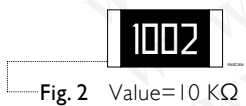

Both E-24 and E-96 series: 4 digits
First three digits for significant figure and 4th digit for number of zeros

For further marking information, please see special data sheet "Chip resistors marking".

CONSTRUCTION

The resistor is constructed on top of a high-grade ceramic body. Internal metal electrodes are added on each end to make the contacts to the thick film resistive element. The composition of the resistive element is a noble metal imbedded into a glass and covered by a second glass to prevent environment influences. The resistor is laser trimmed to the rated resistance value. The resistor is covered with a protective epoxy coat, finally the two external terminations (matte tin on Ni-barrier) are added. See fig.3

OUTLINES

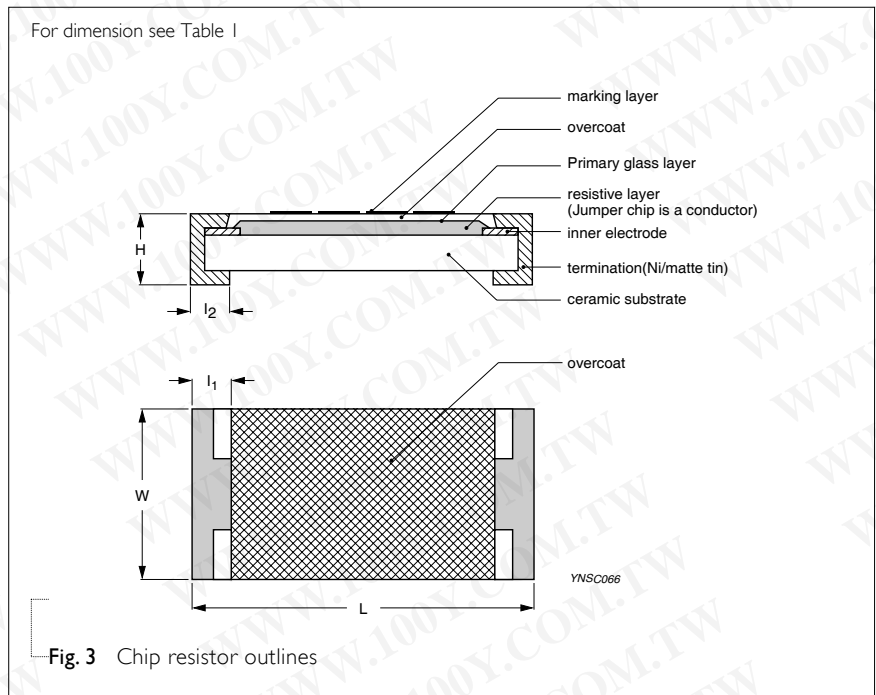

DIMENSIONS

Table I

TYPE	RC1210
L (mm)	3.10 ± 0.10
W (mm)	2.60 ± 0.15
H (mm)	0.50 ± 0.10
l ₁ (mm)	0.45 ± 0.15
l ₂ (mm)	0.50 ± 0.20

勝特力材料 886-3-5753170
 勝特力电子(上海) 86-21-34970699
 勝特力电子(深圳) 86-755-83298787
[Http://www.100y.com.tw](http://www.100y.com.tw)

ELECTRICAL CHARACTERISTICS

Table 2

CHARACTERISTICS	RC1210 1/2 W	
Operating Temperature Range	-55 °C to +155 °C	
Maximum Working Voltage	200 V	
Maximum Overload Voltage	500 V	
Dielectric Withstanding Voltage	500 V	
Resistance Range	5% (E24)	1 Ω to 22 MΩ
	1% (E24/E96)	1 Ω to 10 MΩ
	Zero Ohm Jumper < 0.05 Ω	
Temperature Coefficient	1 Ω ≤ R ≤ 10 Ω	±200 ppm/°C
	10 MΩ ≤ R ≤ 22 MΩ	±200 ppm/°C
	10 Ω < R ≤ 10 MΩ	±100 ppm/°C
Jumper Criteria	Rated Current	2 A
	Maximum Current	10 A

FOOTPRINT AND SOLDERING PROFILES

For recommended footprint and soldering profiles, please see the special data sheet “Chip resistors mounting”.

勝特力材料 886-3-5753170
 勝特力电子(上海) 86-21-34970699
 勝特力电子(深圳) 86-755-83298787
[Http://www.100y.com.tw](http://www.100y.com.tw)

PACKING STYLE AND PACKAGING QUANTITY

Table 3 Packing style and packaging quantity

PRODUCT TYPE	PACKING STYLE	REEL DIMENSION	QUANTITY PER REEL
RC1210	Paper Taping Reel (R)	7" (178 mm)	5,000 units
		13" (330 mm)	20,000 units

NOTE

1. For paper tape and reel specification/dimensions, please see the special data sheet “Packing” document.

FUNCTIONAL DESCRIPTION

POWER RATING

RC1210 rated power at 70°C is 1/2 W

RATED VOLTAGE

The DC or AC (rms) continuous working voltage corresponding to the rated power is determined by the following formula:

$$V = \sqrt{P \times R}$$

or max. working voltage whichever is less

Where

V=Continuous rated DC or AC (rms) working voltage (V)

P=Rated power (W)

R=Resistance value (Ω)

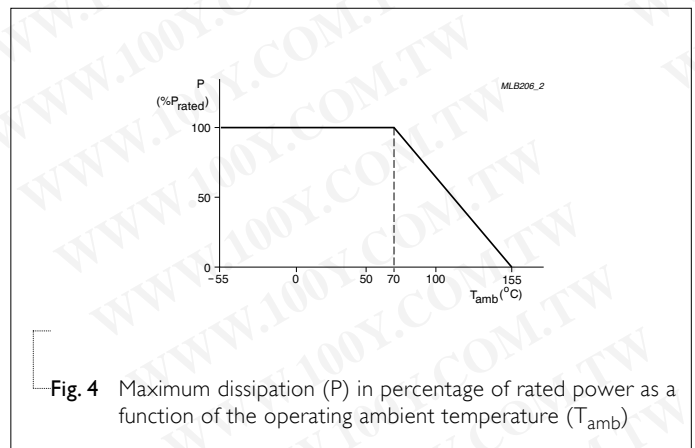

Fig. 4 Maximum dissipation (P) in percentage of rated power as a function of the operating ambient temperature (T_{amb})

TESTS AND REQUIREMENTS

Table 4 Test condition, procedure and requirements

TEST	TEST METHOD	PROCEDURE	REQUIREMENTS
Temperature Coefficient of Resistance (T.C.R.)	IEC 60115-1 4.8	At +25/-55 °C and +25/+125 °C Formula: $T.C.R = \frac{R_2 - R_1}{R_1(t_2 - t_1)} \times 10^6 \text{ (ppm/°C)}$ Where t ₁ =+25 °C or specified room temperature t ₂ =-55 °C or +125 °C test temperature R ₁ =resistance at reference temperature in ohms R ₂ =resistance at test temperature in ohms	Refer to table 2
<p>勝特力材料 886-3-5753170 勝特力电子(上海) 86-21-34970699 勝特力电子(深圳) 86-755-83298787 Http://www.100y.com.tw</p>			
Life/Endurance	IEC 60115-1 4.25.1	At 70±5 °C for 1,000 hours, RCWV applied for 1.5 hours on, 0.5 hour off, still air required	±(1.0%+0.05 Ω) for 1% tol. ±(3.0%+0.05 Ω) for 5% tol. <100 mΩ for Jumper
High Temperature Exposure/Endurance at Upper Category Temperature	IEC 60068-2-2	1,000 hours at 155±5 °C, unpowered	±(1.0%+0.05 Ω) for 1% tol. ±(2.0%+0.05 Ω) for 5% tol. <50 mΩ for Jumper
Moisture Resistance	MIL-STD-202G Method-I06G	Each temperature / humidity cycle is defined at 8 hours, 3 cycles / 24 hours for 10d. with 25 °C / 65 °C 95% R.H, without steps 7a & 7b, unpowered Parts mounted on test-boards, without condensation on parts Measurement at 24±2 hours after test conclusion	±(0.5%+0.05 Ω) for 1% tol. ±(2.0%+0.05 Ω) for 5% tol. <100 mΩ for Jumper
Thermal Shock	MIL-STD-202G Method-I07G	-55/+125 °C Number of cycles required is 300. Devices unmounted Maximum transfer time is 20 seconds. Dwell time is 15 minutes. Air – Air	±(0.5%+0.05 Ω) for 1% tol. ±(1%+0.05 Ω) for 5% tol. <50 mΩ for Jumper
Short Time Overload	IEC60115-1 4.13	2.5 times of rated voltage or maximum overload voltage whichever is less for 5 sec at room temperature	±(1.0%+0.05 Ω) for 1% tol. ±(2.0%+0.05 Ω) for 5% tol. <50 mΩ for Jumper No visible damage

TEST	TEST METHOD	PROCEDURE	REQUIREMENTS														
Board Flex/ Bending	IEC 60068-2-21	Chips mounted on a 90mm glass epoxy resin PCB (FR4) 2 mm bending Bending time: 60±5 seconds	±(1.0%+0.05 Ω) for 1%, 5% tol. <50 mΩ for Jumper No visible damage														
Low Temperature Operation	IEC 60068-2-1	The resistor shall be subjected to a DC rated voltage for 1.5 h-on, 0.5 h-off, at -55±3 °C This constitutes shall be repeated for 96 hours However the applied voltage shall not exceed the maximum operating voltage	±(0.5%+0.05 Ω) for 1% tol. ±(1.0%+0.05 Ω) for 5% tol. No visible damage														
Insulation Resistance	IEC 60115-1 4.6	Rated continuous overload voltage (RCOV) for 1 minute Type RC1210 Voltage (DC) 100 V	≥10 GΩ														
Dielectric Withstand Voltage	IEC 60115-1 4.7	Maximum voltage (V _{rms}) applied for 1 minute Type RC1210 Voltage (AC) 500 V _{rms}	No breakdown or flashover														
Resistance to Solvent	IPC/JEDEC J-STD-020D	Isopropylalcohol (C ₃ H ₇ OH) followed by brushing	No smeared														
Noise	IEC 60115-1 4.12	Maximum voltage (V _{rms}) applied	<table border="1"> <thead> <tr> <th>Resistors range</th> <th>Value</th> </tr> </thead> <tbody> <tr> <td>R < 100 Ω</td> <td>10 dB</td> </tr> <tr> <td>100 Ω ≤ R < 1 KΩ</td> <td>20 dB</td> </tr> <tr> <td>1 KΩ ≤ R < 10 KΩ</td> <td>30 dB</td> </tr> <tr> <td>10 KΩ ≤ R < 100 KΩ</td> <td>40 dB</td> </tr> <tr> <td>100 KΩ ≤ R < 1 MΩ</td> <td>46 dB</td> </tr> <tr> <td>1 MΩ ≤ R ≤ 22 MΩ</td> <td>48 dB</td> </tr> </tbody> </table>	Resistors range	Value	R < 100 Ω	10 dB	100 Ω ≤ R < 1 KΩ	20 dB	1 KΩ ≤ R < 10 KΩ	30 dB	10 KΩ ≤ R < 100 KΩ	40 dB	100 KΩ ≤ R < 1 MΩ	46 dB	1 MΩ ≤ R ≤ 22 MΩ	48 dB
Resistors range	Value																
R < 100 Ω	10 dB																
100 Ω ≤ R < 1 KΩ	20 dB																
1 KΩ ≤ R < 10 KΩ	30 dB																
10 KΩ ≤ R < 100 KΩ	40 dB																
100 KΩ ≤ R < 1 MΩ	46 dB																
1 MΩ ≤ R ≤ 22 MΩ	48 dB																
Biased Humidity (steady state)	IEC 60115-1 4.37	Steady state for 1000 hours at 40 °C / 95% R.H. RCWV applied for 1.5 hours on and 0.5 hour off	±(1.0%+0.05 Ω) for 1% tol. ±(2.0%+0.05 Ω) for 5% tol. <100 mΩ for Jumper														

勝特力材料 886-3-5753170
 勝特力电子(上海) 86-21-34970699
 勝特力电子(深圳) 86-755-83298787
[Http://www.100y.com.tw](http://www.100y.com.tw)

TEST	TEST METHOD	PROCEDURE	REQUIREMENTS
Intermittent Overload	IEC 60115-1 4.39	2.5 times of rated voltage or maximum overload voltage whichever is less for 1 second on and 25 seconds off; total 10,000 cycles	±(1.0%+0.05 Ω) for 1% tol. ±(2.0%+0.05 Ω) for 5% tol. <100 mΩ for Jumper
Solderability - Wetting	IPC/JEDEC J-STD-002B test B	Electrical Test not required Magnification 50X SMD conditions: 1 st step: method B, aging 4 hours at 155 °C dry heat 2 nd step: leadfree solder bath at 245±3 °C Dipping time: 3±0.5 seconds	Well tinned (≥95% covered) No visible damage
- Leaching	IPC/JEDEC J-STD-002B test D	Leadfree solder, 260 °C, 30 seconds immersion time	No visible damage
- Resistance to Soldering Heat	IEC 60068-2-58	Condition B, no pre-heat of samples Leadfree solder, 260 °C, 10 seconds immersion time Procedure 2 for SMD: devices fluxed and cleaned with isopropanol	±(0.5%+0.05 Ω) for 1% tol. ±(1.0%+0.05 Ω) for 5% tol. <50 mΩ for Jumper No visible damage

勝特力材料 886-3-5753170
勝特力电子(上海) 86-21-34970699
勝特力电子(深圳) 86-755-83298787
[Http://www.100y.com.tw](http://www.100y.com.tw)

REVISION HISTORY

REVISION	DATE	CHANGE NOTIFICATION	DESCRIPTION
Version 4	Nov 09, 2009	-	<ul style="list-style-type: none"> - Test items and methods updated - Test requirements upgraded
Version 3	Jul 15, 2008	-	<ul style="list-style-type: none"> - Change to dual brand datasheet that describe RC1210 with RoHS compliant - Description of "Halogen Free Epoxy" added - Define global part number
Version 2	Oct 13, 2004	-	<ul style="list-style-type: none"> - New datasheet for 1210 thick film 1% and 5% with lead-free terminations - Replace the 1210 part of pdf files: PRC101_5_1, PRC102_1_1 - Test method and procedure updated

勝特力材料 886-3-5753170
勝特力电子(上海) 86-21-34970699
勝特力电子(深圳) 86-755-83298787
[Http://www.100y.com.tw](http://www.100y.com.tw)

“Yageo reserves all the rights for revising the content of this datasheet without further notification, as long as the products itself are unchanged. Any product change will be announced by PCN.”