

勝特力材料 886-3-5753170  
 勝特力电子(上海) 86-21-34970699  
 勝特力电子(深圳) 86-755-83298787  
[Http://www.100y.com.tw](http://www.100y.com.tw)

1206 貼片電阻本

封裝：1206 (3.2x1.6mm)

精度：5%精度

170 種型號，每種 50 顆，一共 8500 顆，阻值清單如下：

R1206 (單位：歐姆)							
x1	x10	x100	x1K	x10K	x100K	x1M	x10M
0							
1	10	100	1K	10K	100K	1M	10M
1.1	11	110	1.1K	11K	110K	1.1M	
1.2	12	120	1.2K	12K	120K	1.2M	
1.3	13	130	1.3K	13K	130K	1.3M	
1.5	15	150	1.5K	15K	150K	1.5M	
1.6	16	160	1.6K	16K	160K	1.6M	
1.8	18	180	1.8K	18K	180K	1.8M	
2	20	200	2K	20K	200K	2M	
2.2	22	220	2.2K	22K	220K	2.2M	
2.4	24	240	2.4K	24K	240K	2.4M	
2.7	27	270	2.7K	27K	270K	2.7M	
3	30	300	3K	30K	300K	3M	
3.3	33	330	3.3K	33K	330K	3.3M	
3.6	36	360	3.6K	36K	360K	3.6M	
3.9	39	390	3.9K	39K	390K	3.9M	
4.3	43	430	4.3K	43K	430K	4.3M	
4.7	47	470	4.7K	47K	470K	4.7M	
5.1	51	510	5.1K	51K	510K	5.1M	
5.6	56	560	5.6K	56K	560K	5.6M	
6.2	62	620	6.2K	62K	620K	6.2M	
6.8	68	680	6.8K	68K	680K	6.8M	
7.5	75	750	7.5K	75K	750K	7.5M	
8.2	82	820	8.2K	82K	820K	8.2M	
9.1	91	910	9.1K	91K	910K	9.1M	

# DATA SHEET

## HIGH POWER CHIP RESISTORS

RC high power series

5%, 1%

sizes 0603/0805/1206/2512

RoHS compliant & Halogen free



**SCOPE**

This specification describes RC0603 to RC2512 high power chip resistors with lead-free terminations made by thick film process.

**APPLICATIONS**

- All general purpose applications

**FEATURES**

- Halogen Free Epoxy
- RoHS compliant
  - Products with lead-free terminations meet RoHS requirements
  - Pb-glass contained in electrodes, resistor element and glass are exempted by RoHS
- Reducing environmentally hazardous wastes
- High component and equipment reliability
- Saving of PCB space
- None forbidden-materials used in products/production

**ORDERING INFORMATION - GLOBAL PART NUMBER**

Both part numbers are identified by the series name, size, tolerance, packaging type, temperature coefficient, taping reel, resistance value and resistor terminal.

**GLOBAL PART NUMBER (PREFERRED)**

**RC XXXX X X - XX XXXX L**  
 (1) (2) (3) (4) (5) (6) (7)

**(1) SIZE**

0603 / 0805 / 1206 / 2512

**(2) TOLERANCE**

F = ±1%  
 J = ±5%

**(3) PACKAGING TYPE**

R = Paper taping reel  
 K = Embossed taping reel

**(4) TEMPERATURE COEFFICIENT OF RESISTANCE**

- = Base on spec

**(5) TAPING REEL**

7W = 2 × standard power

**(6) RESISTANCE VALUE**

There are 2~4 digits indicated the resistor value. Letter R/K/M is decimal point, no need to mention the last zero after R/K/M, e.g. 1K2, not 1K20.  
 Detailed resistance rules show in table of "Resistance rule of global part number".

**(7) OPTIONAL CODE**

Letter L is system default code for ordering only (Note)

Resistance coding rule	Example
OR	OR = Jumper
XRXX (1 to 9.76 Ω)	1R = 1 Ω 1R5 = 1.5 Ω 9R76 = 9.76 Ω
XXRX (10 to 97.6 Ω)	10R = 10 Ω 97R6 = 97.6 Ω
XXXR (100 to 976 Ω)	100R = 100 Ω
XKXX (1 to 9.76 KΩ)	1K = 1,000 Ω 9K76 = 9760 Ω
XMXX (1 to 9.76 MΩ)	1M = 1,000,000 Ω 9M76 = 9,760,000 Ω

**ORDERING EXAMPLE**

The ordering code of a RC2512 chip resistor, value 47 Ω, 2W with ±5% tolerance, supplied in 7-inch tape reel is: RC2512JR-7W47RL.

**NOTE**

1. All our RSMD products are RoHS compliant and Halogen free. "LFP" of the internal 2D reel label states "Lead-Free Process"
2. On customized label, "LFP" or specific symbol can be printed

**MARKING**

RC0603/0805/1206/2512



E-24 series: 3 digits for 5%  
First two digits for significant figure and 3rd digit for number of zeros

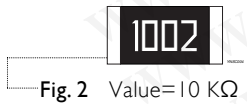

Both E-24 and E-96 series: 4 digits for 1%  
First three digits for significant figure and 4th digit for number of zeros

For further marking information, please see special data sheet “Chip resistors marking”.

**CONSTRUCTION**

The resistor is constructed on top of a high-grade ceramic body. Internal metal electrodes are added on each end to make the contacts to the thick film resistive element. The composition of the resistive element is a noble metal embedded into a glass and covered by a second glass to prevent environmental influences. The resistor is laser trimmed to the rated resistance value. The resistor is covered with a protective epoxy coat, finally the two external terminations (matte tin on Ni-barrier) are added. See fig. 3.

**DIMENSIONS**

Table I For outlines see fig. 3

TYPE	L (mm)	W (mm)	H (mm)	l <sub>1</sub> (mm)	l <sub>2</sub> (mm)
RC0603	1.60 ±0.10	0.80 ±0.10	0.45 ±0.10	0.25 ±0.15	0.25 ±0.15
RC0805	2.00 ±0.10	1.25 ±0.10	0.50 ±0.10	0.35 ±0.20	0.35 ±0.20
RC1206	3.10 ±0.10	1.60 ±0.10	0.55 ±0.10	0.45 ±0.20	0.40 ±0.20
RC2512	6.35 ±0.10	3.10 ±0.15	0.55 ±0.10	0.60 ±0.20	0.50 ±0.20

**OUTLINES**

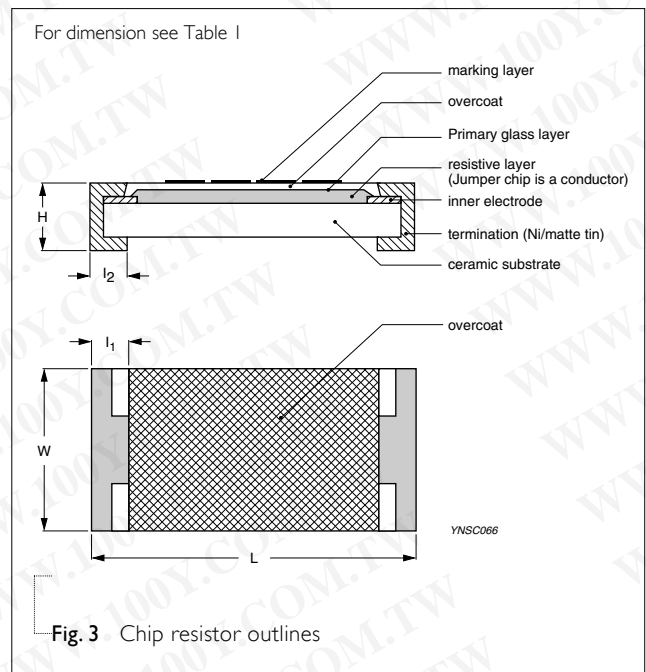

Fig. 3 Chip resistor outlines

**ELECTRICAL CHARACTERISTICS**

Table 2

TYPE	Resistance Range	Operating Temperature Range	Power Rating	Max. Working Vol.	Dielectric Withstand Vol.	Max. Overload Vol.	Temperature Coefficient of Resistance
RC0603	$1 \Omega \leq R \leq 10 \text{ K}\Omega$	-55 °C to +155 °C	1/5 W	50 V	100 V	100 V	±200 ppm/°C
RC0805	$1 \Omega \leq R \leq 1 \text{ M}\Omega$		1/4 W	150 V	300 V	300 V	
RC1206			1/2 W	200 V	400 V	500 V	
RC2512			$1 \Omega \leq R \leq 150\Omega$	2 W	200 V	400 V	

**FOOTPRINT AND SOLDERING PROFILES**

For recommended footprint and soldering profiles, please see the special data sheet “Chip resistors mounting”.

**PACKING STYLE AND PACKAGING QUANTITY**

Table 3 Packing style and packaging quantity

PACKING STYLE	REEL DIMENSION	RC0603	RC0805	RC1206	RC2512
Paper taping reel (R)	7" (178 mm)	5,000	5,000	5,000	---
	10" (254 mm)	10,000	10,000	10,000	---
	13" (330 mm)	20,000	20,000	20,000	---
Embossed taping reel (K)	7" (178 mm)	---	---	---	4,000

**NOTE**

1. For paper/embossed tape and reel specification/dimensions, please see the special data sheet “Chip resistors packing”.

**FUNCTIONAL DESCRIPTION**

**OPERATING TEMPERATURE RANGE**

Range: -55 °C to +155 °C

**POWER RATING**

Each type rated power at 70 °C:  
RC0603=1/5 W; RC0805=1/4 W; RC1206=1/2 W;  
RC2512=2 W

**RATED VOLTAGE**

The DC or AC (rms) continuous working voltage corresponding to the rated power is determined by the following formula:

$$V = \sqrt{P \times R}$$

Where

V = Continuous rated DC or AC (rms) working voltage (V)

P = Rated power (W)

R = Resistance value ( $\Omega$ )

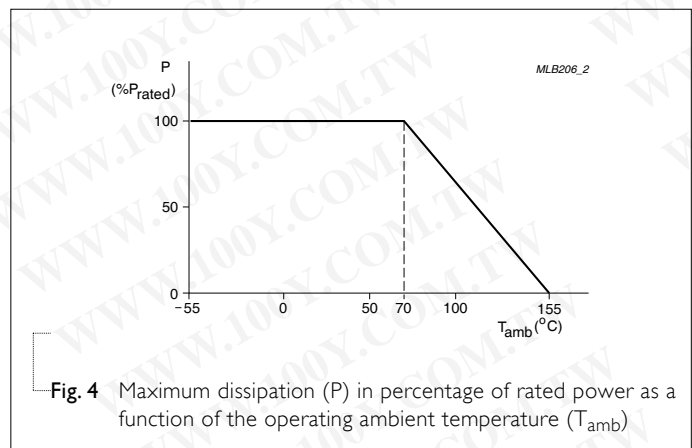

Fig. 4 Maximum dissipation (P) in percentage of rated power as a function of the operating ambient temperature (T<sub>amb</sub>)

**TESTS AND REQUIREMENTS**

**Table 4** Test condition, procedure and requirements

TEST	TEST METHOD	PROCEDURE	REQUIREMENTS
Temperature Coefficient of Resistance (T.C.R.)	IEC 60115-1 4.8	At +25/-55 °C and +25/+125 °C  <b>Formula:</b> $T.C.R = \frac{R_2 - R_1}{R_1(t_2 - t_1)} \times 10^6 \text{ (ppm/°C)}$ Where t <sub>1</sub> =+25 °C or specified room temperature t <sub>2</sub> =-55 °C or +125 °C test temperature R <sub>1</sub> =resistance at reference temperature in ohms R <sub>2</sub> =resistance at test temperature in ohms	Refer to table 2
Life/Endurance	IEC 60115-1 4.25.1	At 70±5 °C for 1,000 hours, RCWV applied for 1.5 hours on, 0.5 hour off, still air required	±(1.0%+0.05 Ω) for 1% tol. ±(3.0%+0.05 Ω) for 5% tol.
High Temperature Exposure/Endurance at Upper Category Temperature	IEC 60068-2-2	1,000 hours at 155±5 °C, unpowered	±(1.0%+0.05 Ω) for 1% tol. ±(2.0%+0.05 Ω) for 5% tol.
Moisture Resistance	MIL-STD-202G Method-I06G	Each temperature / humidity cycle is defined at 8 hours, 3 cycles / 24 hours for 10d. with 25 °C / 65 °C 95% R.H, without steps 7a & 7b, unpowered  Parts mounted on test-boards, without condensation on parts  Measurement at 24±2 hours after test conclusion	±(0.5%+0.05 Ω) for 1% tol. ±(2.0%+0.05 Ω) for 5% tol.
Thermal Shock	MIL-STD-202G Method-I07G	-55/+125 °C  Number of cycles required is 300. Devices unmounted  Maximum transfer time is 20 seconds. Dwell time is 15 minutes. Air – Air	±(0.5%+0.05 Ω) for 1% tol. ±(1%+0.05 Ω) for 5% tol.
Short Time Overload	IEC60115-1 4.13	2.5 times of rated voltage or maximum overload voltage whichever is less for 5 sec at room temperature	±(1.0%+0.05 Ω) for 1% tol. ±(2.0%+0.05 Ω) for 5% tol. No visible damage

TEST	TEST METHOD	PROCEDURE	REQUIREMENTS												
Board Flex/ Bending	IEC 60068-2-21	Chips mounted on a 90mm glass epoxy resin PCB (FR4)  5 mm bending  Bending time: 60±5 seconds	±(1.0%+0.05 Ω) for 1%, 5% tol.  No visible damage												
Low Temperature Operation	IEC 60068-2-1	The resistor shall be subjected to a DC rated voltage for 1.5 h-on, 0.5 h-off, at -55±3 °C  This constitutes shall be repeated for 96 hours  However the applied voltage shall not exceed the maximum operating voltage	±(0.5%+0.05 Ω) for 1% tol. ±(1.0%+0.05 Ω) for 5% tol.  No visible damage												
Insulation Resistance	IEC 60115-1 4.6	Rated continuous overload voltage (RCOV) for 1 minute	≥10 GΩ												
Dielectric Withstand Voltage	IEC 60115-1 4.7	Maximum voltage (V <sub>ms</sub> ) applied for 1 minute	No breakdown or flashover												
Resistance to Solvent	IPC/JEDEC J-STD-020D	Isopropylalcohol (C <sub>3</sub> H <sub>7</sub> OH) followed by brushing	No smeared												
Noise	IEC 60115-1 4.12	Maximum voltage (V <sub>rms</sub> ) applied	<table border="1"> <thead> <tr> <th>Resistors range</th> <th>Value</th> </tr> </thead> <tbody> <tr> <td>R &lt; 100 Ω</td> <td>10 dB</td> </tr> <tr> <td>100 Ω ≤ R &lt; 1 KΩ</td> <td>20 dB</td> </tr> <tr> <td>1 KΩ ≤ R &lt; 10 KΩ</td> <td>30 dB</td> </tr> <tr> <td>10 KΩ ≤ R &lt; 100 KΩ</td> <td>40 dB</td> </tr> <tr> <td>100 KΩ ≤ R &lt; 1 MΩ</td> <td>46 dB</td> </tr> </tbody> </table>	Resistors range	Value	R < 100 Ω	10 dB	100 Ω ≤ R < 1 KΩ	20 dB	1 KΩ ≤ R < 10 KΩ	30 dB	10 KΩ ≤ R < 100 KΩ	40 dB	100 KΩ ≤ R < 1 MΩ	46 dB
Resistors range	Value														
R < 100 Ω	10 dB														
100 Ω ≤ R < 1 KΩ	20 dB														
1 KΩ ≤ R < 10 KΩ	30 dB														
10 KΩ ≤ R < 100 KΩ	40 dB														
100 KΩ ≤ R < 1 MΩ	46 dB														
Biased Humidity (steady state)	IEC 60115-1 4.37	Steady state for 1000 hours at 40 °C / 95% R.H. RCWV applied for 1.5 hours on and 0.5 hour off	±(1.0%+0.05 Ω) for 1% tol. ±(2.0%+0.05 Ω) for 5% tol.												
Intermittent Overload	IEC 60115-1 4.39	2.5 times of rated voltage or maximum overload voltage whichever is less for 1 second on and 25 seconds off; total 10,000 cycles	±(1.0%+0.05 Ω) for 1% tol. ±(2.0%+0.05 Ω) for 5% tol.												

TEST	TEST METHOD	PROCEDURE	REQUIREMENTS
<b>Solderability</b> - Wetting	IPC/JEDEC J-STD-002B test B	Electrical Test not required Magnification 50X SMD conditions: 1 <sup>st</sup> step: method B, aging 4 hours at 155 °C dry heat 2 <sup>nd</sup> step: lead-free solder bath at 245±3 °C Dipping time: 3±0.5 seconds	Well tinned (≥95% covered) No visible damage
- Leaching	IPC/JEDEC J-STD-002B test D	Lead-free solder, 260 °C, 30 seconds immersion time	No visible damage
- Resistance to Soldering Heat	IEC 60068-2-58	Condition B, no pre-heat of samples Lead-free solder, 260 °C, 10 seconds immersion time Procedure 2 for SMD: devices fluxed and cleaned with isopropanol	±(0.5%+0.05 Ω) for 1% tol. ±(1.0%+0.05 Ω) for 5% tol. No visible damage

REVISION HISTORY

REVISION	DATE	CHANGE NOTIFICATION	DESCRIPTION
----------	------	---------------------	-------------

Version 0	Dec 14, 2010	-	- First issue of this specification
-----------	--------------	---	-------------------------------------

*“Yageo reserves all the rights for revising the content of this datasheet without further notification, as long as the products itself are unchanged. Any product change will be announced by PCN.”*