

2N6400 Series

Preferred Device

Silicon Controlled Rectifiers

Reverse Blocking Thyristors

Designed primarily for half-wave ac control applications, such as motor controls, heating controls and power supplies; or wherever half-wave silicon gate-controlled, solid-state devices are needed.

- Glass Passivated Junctions with Center Gate Geometry for Greater Parameter Uniformity and Stability
- Small, Rugged, Thermowatt Construction for Low Thermal Resistance, High Heat Dissipation and Durability
- Blocking Voltage to 800 Volts
- Device Marking: Logo, Device Type, e.g., 2N6400, Date Code

*MAXIMUM RATINGS ($T_J = 25^\circ\text{C}$ unless otherwise noted)

Rating	Symbol	Value	Unit
Peak Repetitive Off-State Voltage (Note 1.) ($T_J = -40$ to 125°C , Sine Wave 50 to 60 Hz; Gate Open)	V_{DRM} , V_{RRM}	50 100 200 400 600 800	Volts
On-State RMS Current (180° Conduction Angles; $T_C = 100^\circ\text{C}$)	$I_{T(RMS)}$	16	A
Average On-State Current (180° Conduction Angles; $T_C = 100^\circ\text{C}$)	$I_{T(AV)}$	10	A
Peak Non-repetitive Surge Current (1/2 Cycle, Sine Wave 60 Hz, $T_J = 90^\circ\text{C}$)	I_{TSM}	160	A
Circuit Fusing ($t = 8.3$ ms)	I^2t	145	A^2s
Forward Peak Gate Power (Pulse Width ≤ 1.0 μs , $T_C = 100^\circ\text{C}$)	P_{GM}	20	Watts
Forward Average Gate Power ($t = 8.3$ ms, $T_C = 100^\circ\text{C}$)	$P_{G(AV)}$	0.5	Watts
Forward Peak Gate Current (Pulse Width ≤ 1.0 μs , $T_C = 100^\circ\text{C}$)	I_{GM}	2.0	A
Operating Junction Temperature Range	T_J	-40 to +125	$^\circ\text{C}$
Storage Temperature Range	T_{stg}	-40 to +150	$^\circ\text{C}$

*Indicates JEDEC Registered Data.

1. V_{DRM} and V_{RRM} for all types can be applied on a continuous basis. Ratings apply for zero or negative gate voltage; however, positive gate voltage shall not be applied concurrent with negative potential on the anode. Blocking voltages shall not be tested with a constant current source such that the voltage ratings of the devices are exceeded.



ON Semiconductor™

SCRs
 16 AMPERES RMS
 50 thru 800 VOLTS

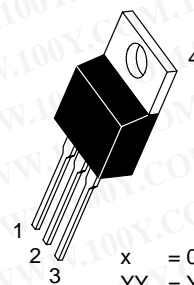

TO-220AB
 CASE 221A
 STYLE 3

x = 0, 1, 2, 3, 4 or 5
 YY = Year
 WW = Work Week

MARKING
 DIAGRAM

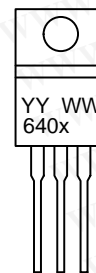

PIN ASSIGNMENT

1	Cathode
2	Anode
3	Gate
4	Anode

ORDERING INFORMATION

Device	Package	Shipping
2N6400	TO220AB	500/Box
2N6401	TO220AB	500/Box
2N6402	TO220AB	500/Box
2N6403	TO220AB	500/Box
2N6404	TO220AB	500/Box
2N6405	TO220AB	500/Box

Preferred devices are recommended choices for future use and best overall value.

2N6400 Series

THERMAL CHARACTERISTICS

Characteristic	Symbol	Max	Unit
Thermal Resistance, Junction to Case	$R_{\theta JC}$	1.5	$^{\circ}C/W$
Maximum Lead Temperature for Soldering Purposes 1/8" from Case for 10 Seconds	T_L	260	$^{\circ}C$

ELECTRICAL CHARACTERISTICS ($T_C = 25^{\circ}C$ unless otherwise noted.)

Characteristic	Symbol	Min	Typ	Max	Unit
----------------	--------	-----	-----	-----	------

OFF CHARACTERISTICS

*Peak Repetitive Forward or Reverse Blocking Current ($V_{AK} = \text{Rated } V_{DRM} \text{ or } V_{RRM}, \text{ Gate Open}$)	I_{DRM}, I_{RRM}	–	–	10	μA
$T_J = 25^{\circ}C$					
$T_J = 125^{\circ}C$		–	–	2.0	mA

ON CHARACTERISTICS

*Peak Forward On-State Voltage ($I_{TM} = 32 \text{ A Peak, Pulse Width } \leq 1 \text{ ms, Duty Cycle } \leq 2\%$)	V_{TM}	–	–	1.7	Volts
*Gate Trigger Current (Continuous dc) ($V_D = 12 \text{ Vdc, } R_L = 100 \text{ Ohms}$)	I_{GT}	–	9.0	30	mA
$T_C = 25^{\circ}C$		–	–	60	
$T_C = -40^{\circ}C$					
*Gate Trigger Voltage (Continuous dc) ($V_D = 12 \text{ Vdc, } R_L = 100 \text{ Ohms}$)	V_{GT}	–	0.7	1.5	Volts
$T_C = 25^{\circ}C$		–	–	2.5	
$T_C = -40^{\circ}C$					
Gate Non-Trigger Voltage ($V_D = 12 \text{ Vdc, } R_L = 100 \text{ Ohms}$)	V_{GD}	0.2	–	–	Volts
*Holding Current ($V_D = 12 \text{ Vdc, Initiating Current} = 200 \text{ mA, Gate Open}$)	I_H	–	18	40	mA
$T_C = 25^{\circ}C$		–	–	60	
* $T_C = -40^{\circ}C$					
Turn-On Time ($I_{TM} = 16 \text{ A, } I_{GT} = 40 \text{ mAdc, } V_D = \text{Rated } V_{DRM}$)	t_{gt}	–	1.0	–	μs
Turn-Off Time ($I_{TM} = 16 \text{ A, } I_R = 16 \text{ A, } V_D = \text{Rated } V_{DRM}$)	t_q	–	15	–	μs
$T_C = 25^{\circ}C$		–	35	–	
$T_J = +125^{\circ}C$					

DYNAMIC CHARACTERISTICS

Critical Rate-of-Rise of Off-State Voltage ($V_D = \text{Rated } V_{DRM}, \text{ Exponential Waveform}$)	dv/dt	–	50	–	$V/\mu s$
$T_J = +125^{\circ}C$					

*Indicates JEDEC Registered Data.

勝特力材料 886-3-5753170
 勝特力电子(上海) 86-21-54151736
 勝特力电子(深圳) 86-755-83298787
[Http://www.100y.com.tw](http://www.100y.com.tw)

2N6400 Series

Voltage Current Characteristic of SCR

Symbol	Parameter
V_{DRM}	Peak Repetitive Off State Forward Voltage
I_{DRM}	Peak Forward Blocking Current
V_{RRM}	Peak Repetitive Off State Reverse Voltage
I_{RRM}	Peak Reverse Blocking Current
V_{TM}	Peak On State Voltage
I_H	Holding Current

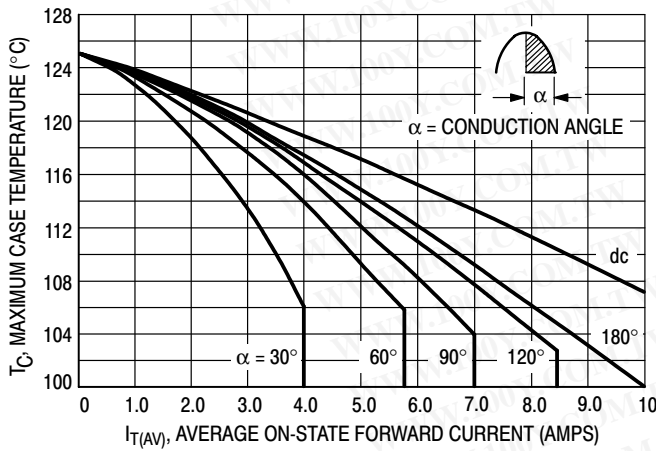
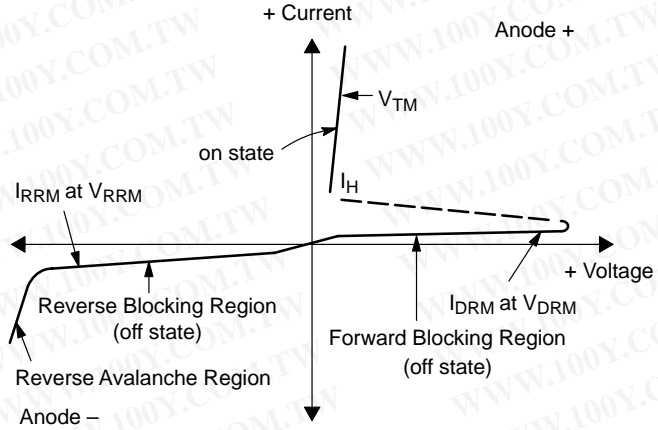

Figure 1. Average Current Derating

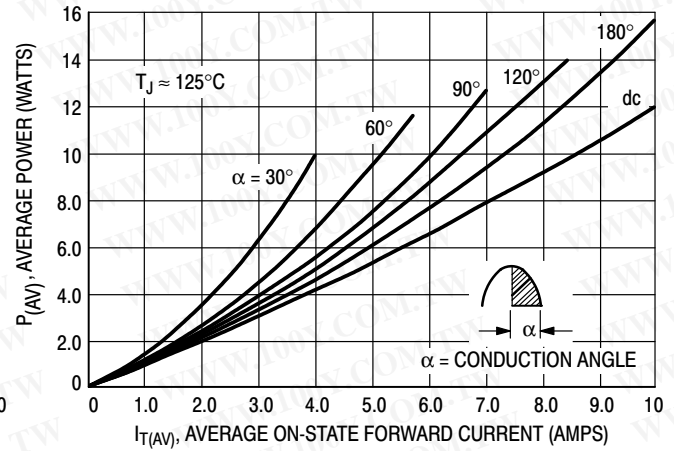

Figure 2. Maximum On-State Power Dissipation

勝特力材料 886-3-5753170
 勝特力电子(上海) 86-21-54151736
 勝特力电子(深圳) 86-755-83298787
[Http://www.100y.com.tw](http://www.100y.com.tw)

2N6400 Series

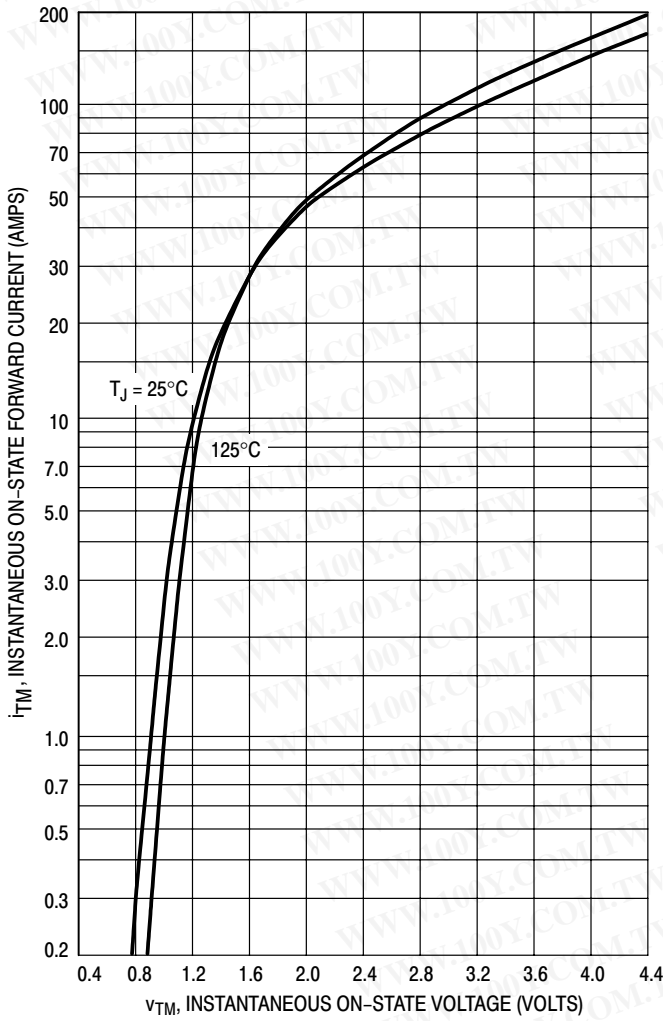

Figure 3. On-State Characteristics

勝特力材料 886-3-5753170
 勝特力电子(上海) 86-21-54151736
 勝特力电子(深圳) 86-755-83298787
[Http://www.100y.com.tw](http://www.100y.com.tw)

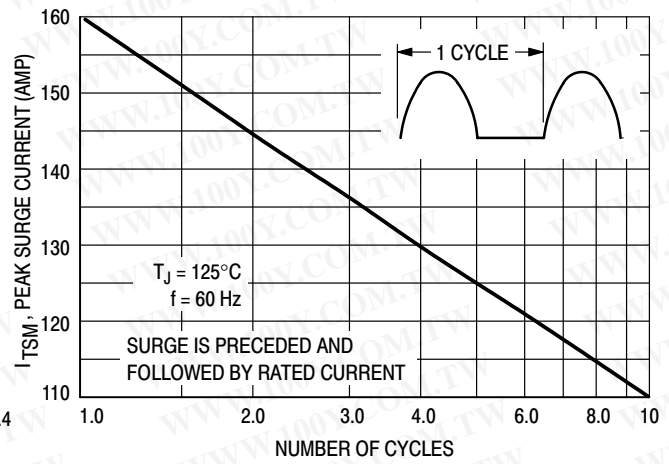

Figure 4. Maximum Non-Repetitive Surge Current

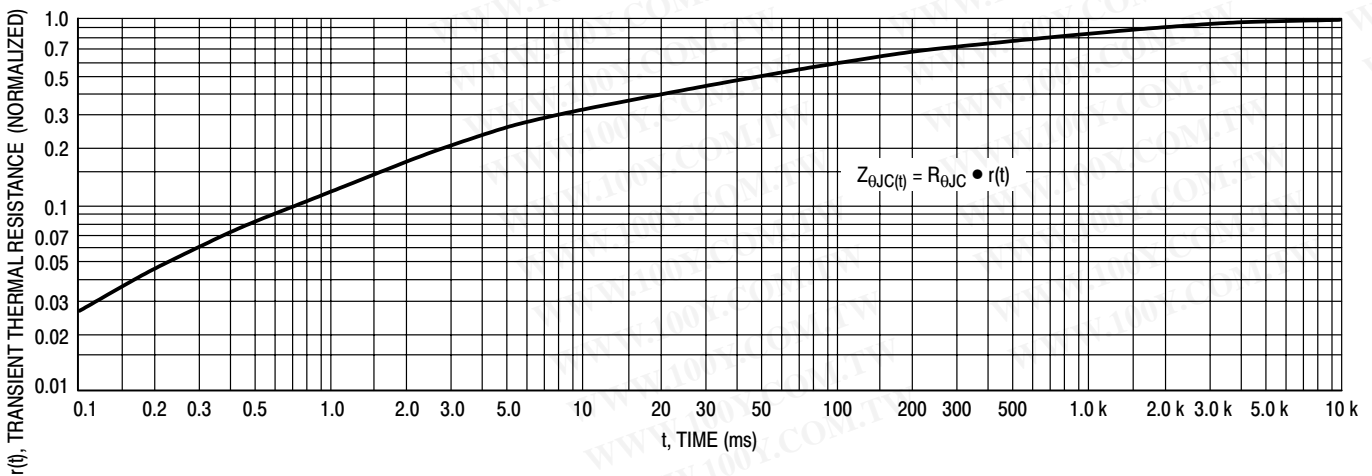

Figure 5. Thermal Response

2N6400 Series

TYPICAL CHARACTERISTICS

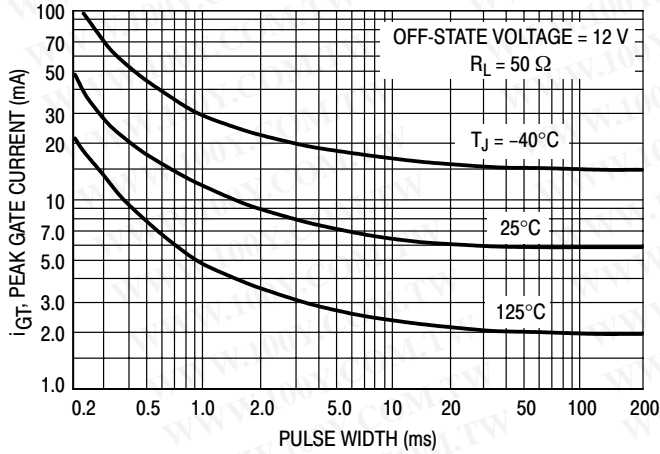

Figure 6. Typical Gate Trigger Current versus Pulse Width

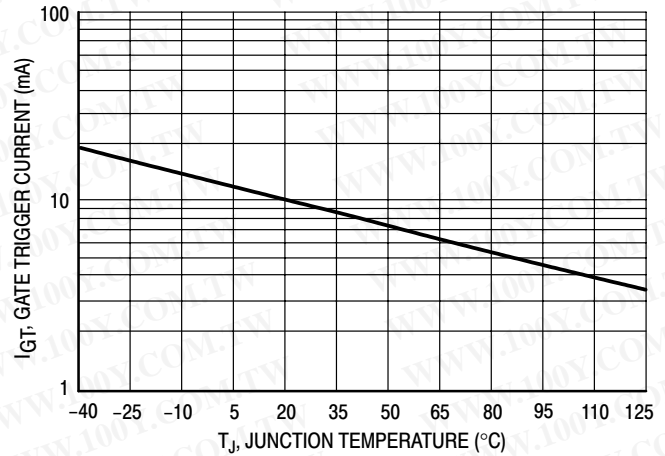

Figure 7. Typical Gate Trigger Current versus Junction Temperature

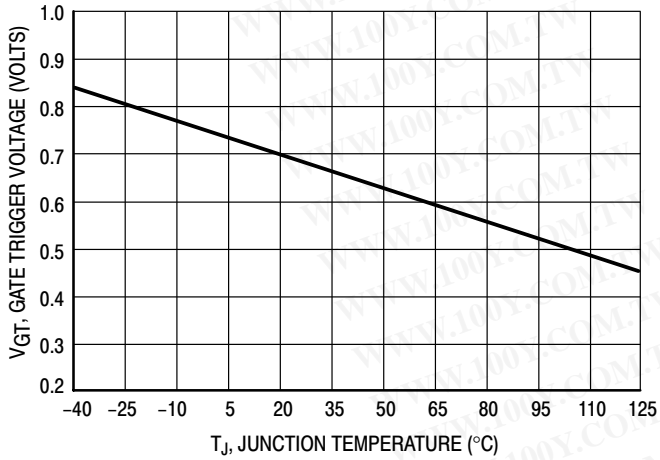

Figure 8. Typical Gate Trigger Voltage versus Junction Temperature

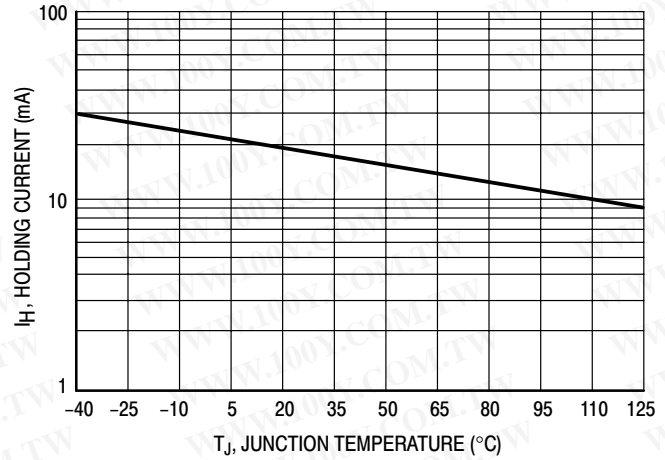

Figure 9. Typical Holding Current versus Junction Temperature

勝特力材料 886-3-5753170
 勝特力电子(上海) 86-21-54151736
 勝特力电子(深圳) 86-755-83298787
[Http://www.100y.com.tw](http://www.100y.com.tw)

2N6400 Series

PACKAGE DIMENSIONS

TO-220AB
CASE 221A-07
ISSUE AA

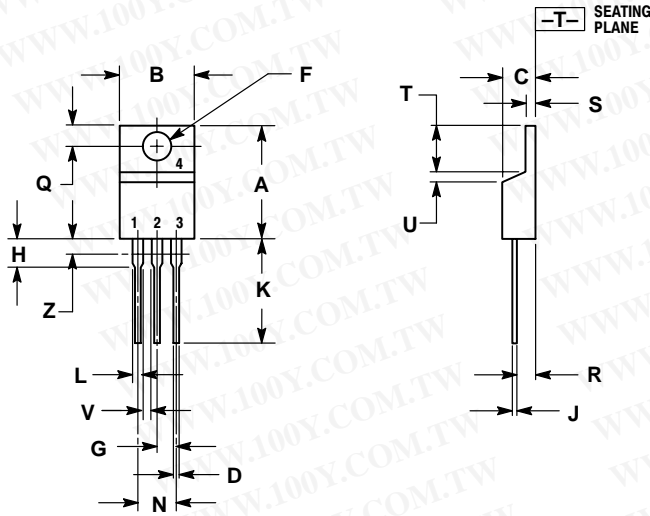

- NOTES:
1. DIMENSIONING AND TOLERANCING PER ANSI Y14.5M, 1982.
 2. CONTROLLING DIMENSION: INCH.
 3. DIMENSION Z DEFINES A ZONE WHERE ALL BODY AND LEAD IRREGULARITIES ARE ALLOWED.

DIM	INCHES		MILLIMETERS	
	MIN	MAX	MIN	MAX
A	0.570	0.620	14.48	15.75
B	0.380	0.405	9.66	10.28
C	0.160	0.190	4.07	4.82
D	0.025	0.035	0.64	0.88
F	0.142	0.147	3.61	3.73
G	0.095	0.105	2.42	2.66
H	0.110	0.155	2.80	3.93
J	0.014	0.022	0.36	0.55
K	0.500	0.562	12.70	14.27
L	0.045	0.060	1.15	1.52
N	0.190	0.210	4.83	5.33
Q	0.100	0.120	2.54	3.04
R	0.080	0.110	2.04	2.79
S	0.045	0.055	1.15	1.39
T	0.235	0.255	5.97	6.47
U	0.000	0.050	0.00	1.27
V	0.045	---	1.15	---
Z	---	0.080	---	2.04

- STYLE 3:
PIN 1. CATHODE
2. ANODE
3. GATE
4. ANODE

勝特力材料 886-3-5753170
 胜特力电子(上海) 86-21-54151736
 胜特力电子(深圳) 86-755-83298787
[Http://www.100y.com.tw](http://www.100y.com.tw)