

勝特力電材超市-龍山店 886-3-5773766
勝特力電材超市-光復店 886-3-5729570
勝特力電子(上海) 86-21-34970699
勝特力電子(深圳) 86-755-83298787
<http://www.100y.com.tw>

Rotary Solenoids

Design and Features, etc.	6
General Characteristics	8
How to Select a Solenoid	8
Ordering Information	8
Size 301	10
Size 341	11
Size 401	12
Size 490	13
Size 491	14
Size 590	15
Size 591	16
Size 700	17
Size 870	18
Size 874	19
Characteristics Table	20
Ampere-Turn vs Torque Graphs	22
Ampere-Turn vs Response Time	23

ROTARY SOLENOIDS

1. Design and Features

The rotary solenoid's design starts from a standard flat face push-pull solenoid. The rotary solenoid then incorporates the mechanical design principle of an inclined plane to convert linear motion to rotary motion. There are three uniform inclined planes (spiral grooves) that are stamped into both the case and the armature, called "ball races". The "ball races" provide both a means of converting linear motion to rotary motion and a secondary bearing system to support this rotary motion.

(Fig. 1)

- The ball races are specially designed and provide a constant torque output over the complete angle of rotation at 25% duty cycle.
- The rotary solenoid uses an enclosed coil and therefore provides maximum magnetic efficiency.
- The magnetic circuit is very short, so high efficiencies in terms of torque output can be obtained, and energization/ response times are very quick.

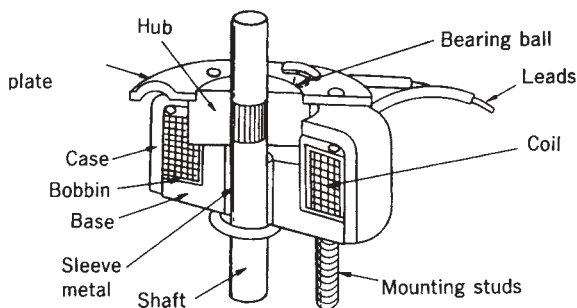

Fig. 1

2. Starting Torque

The starting torque shown in the catalog is the gross value output at 20 deg.C. With the addition of the return spring, the solenoid's net output is the gross starting torque minus the return spring torque.

3. Rotation Angle Direction of Rotation

A) Use of an External Stopper (Fig. 2)

The angle and direction of rotation are predetermined (and fixed) by the manufacturing process of the three ball races that are in the case and armature.

The degree of rotation can be reduced (example : a 35 deg RH rotation solenoid reduced to 30 deg RH rotation), by the use of an external stopper. However, to assure that the solenoid operates properly, it is imperative that the solenoid armature always be allowed to return to 0 deg. or unenergized position.

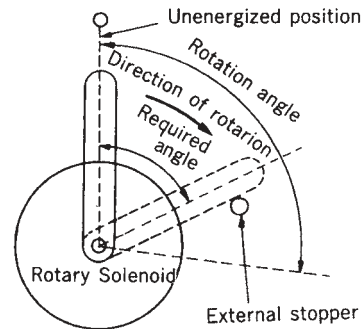

Fig. 2

B) Direction of Rotation (Fig. 3)

The normally accepted convention to describe the rotation of the rotary solenoid is that the direction of rotation is viewed from the armature plate (top) of the solenoid. Clockwise rotation is right hand (RH) rotation, and counter clockwise rotation is left-hand (LH) rotation.

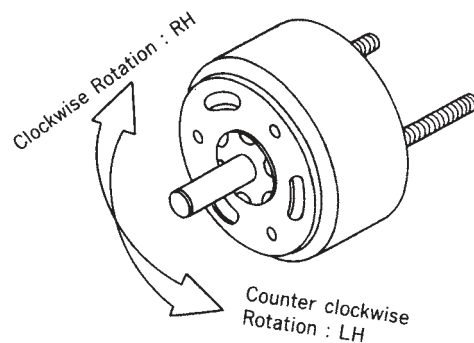

Fig. 3

ROTARY SOLENOIDS

C) Rotation Angle Available

The rotation angles are available as follows.

Table 1

SIZE301	25°, 35°, 45°	RH and LH
SIZE341	25°, 35°, 45°, 67.5°	RH and LH
SIZE401	25°, 35°, 45°, 67.5°, 95°	RH and LH
SIZE490, 491		
SIZE590, 591		
SIZE700		
SIZE870		

4. Axial Travel

In this design of the rotary solenoid the rotary motion is created by converting linear motion into rotary motion. The use of the inclined plane (ball races) also generate a small axial stroke (about 0.7 to 2.6 mm depending upon the amount of rotation and the size of the solenoid).

Table 2

SIZE	301	341	401	490, 491	590, 591	700	870, 874
Axial travel (mm), approx.	0.7	0.9	1.2	1.5	1.6	2.3	2.6

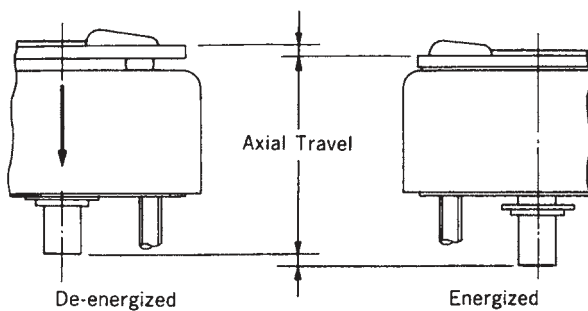
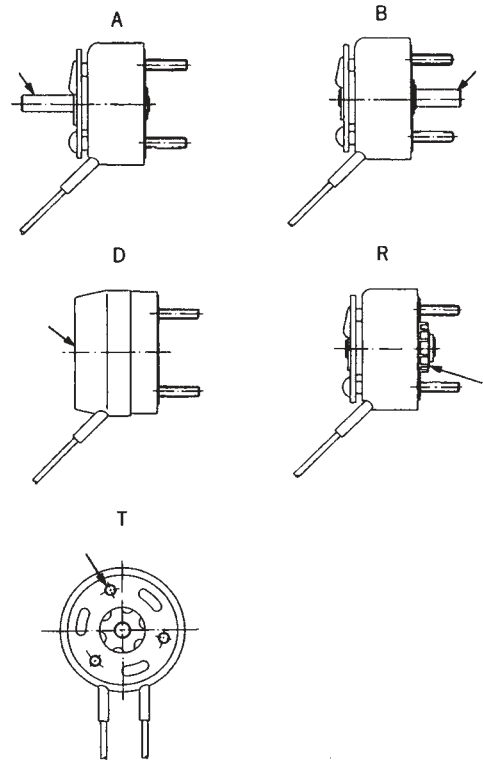

Fig. 4

5. Standard Available Accessories

The standard rotary solenoid is available with different accessories to meet your application requirements.



- A: Shaft extension on the armature plate
- B: Shaft extension on the base side
- D: Dust cover over armature plate
- R: Return spring provided
- T: Tapped holes in armature plate

6. Operational Considerations

A) Temperature

The coil data of rotary solenoids shows the values at ambient temperature 20° C and with a standard heat sink. When a solenoid is used at the ratings mentioned in the coil data, it is designed so that the coil temperature rises and reaches equilibrium at approximately 85° C. In applications where the ambient temperature is higher than 20° C or the heat sink is smaller than indicated in the catalog, possible thermal damage can occur. Temperature rise tests should be performed by the customer to assure that the coil does not reach 120° C. Coils can be constructed to operate at temperatures higher than 120° C without thermal damage. Please consult the factory for details.

ROTARY SOLENOIDS

B) Shaft Modifications

It is not recommended that the customer modify the shaft, as the shafts are fabricated before assembly. Any special configurations can be supplied. Please consult the factory for details.

C) How To Use The "T" (tapped armature plate) Feature

As noted above, the rotary solenoid does not have axial movement in the armature plate position during energization and de-energization. When directly attaching a mechanism to the armature plate, the load must allow for free movement in the axial direction. Also, the attaching screws can not be longer than the thickness of the armature plate or interference in the rotary motion will occur.

7. General Characteristics

Insulation class	Class E (120° C) Lead wire class A (105° C)
Dielectric strength	AC 1000V 50/60 Hz 1 min. (at normal temperature and normal humidity)
Insulation resistance	More than 100 Mohm at DC 500V megger (at normal temperature and normal humidity)
Expected life	Standard life : 2 million cycles Extended life : 10 million cycles Long life : 50 million cycles (Solenoid cycle life is very dependent upon side load, frequency of use, and environmental conditions. Cycle life tests should be performed by the customer.)

8. How to Select a Rotary Solenoid

Before selecting a rotary solenoid, the following information must be determined :

A) Torque

The actual torque required in the application should be increased using a safety factor multiplier of 1.5 to arrive at the torque value that should be used in your specification.

B) Duty Cycle

Use the aforementioned formula to calculate duty cycle. Also note the maximum on time. (See page 2)

C) Rotation Angle

Rotation angle is determined by application requirements.

D) Rotation Direction

Rotation direction is determined by application requirements (note direction of armature plate).

E) Operating Voltage

Operating DC voltage is determined by the application and voltage available.

After determining these specifications, one can find the correct size solenoid for the application, using the torque characteristics tables. The coil data is also shown for different sizes of magnet wire. If the exact operating voltage is not in the coil data table, use the nearest voltage shown in the table.

NOTE : When the operating voltage falls between 2 coil sizes, always use the higher AWG numbered coil so as to prevent potential thermal damage. To determine the torque output of the solenoid after temperature rise, please use the amp-turn gross torque tables (pages 22) after calculating the amp-turns.

9. Ordering Information

●When ordering a rotary solenoid, the correct part number needs to be determined, from the following combination of characteristics (1-5):

- (1) M-Metric Thread
F-SAE Thread
- (2) Solenoid Size (example-490)
- (3) Coil Wire Size (AWG no.)
- (4) Angle of rotation, direction of rotation and accessories (table 3)
- (5) R-Standard Life Bearing
RE-Extended Life Bearing
RL-Long Life Bearing

●Example of a complete part number :

(1) (2) (3) (4) (5)
F 490 26 141 R

This part number is for a solenoid with (1)SAE threads, (2)size 490,(3) 26 AWG coil wire, (4) 35 deg. right-hand rotation, with accessories of armature side shaft extension and return spring provided, (5) and standard life bearings.

ROTARY SOLENOIDS

10. Labeling

For rotary solenoids the part number labeling is as follows:

A) Standard Solenoid (no modifications).

The solenoid label will have the part number and the date code (which identifies the year and week of manufacture).

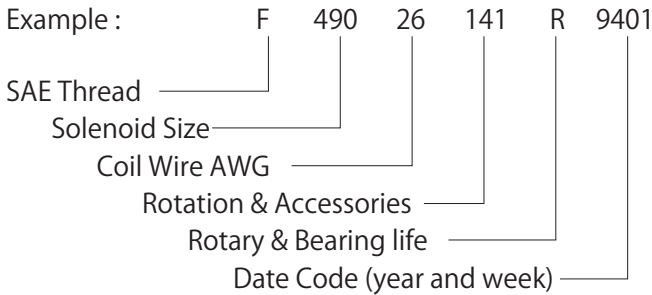

B) Special Configuration (required for any modification to a standard design)

Any change from the standard catalog design requires that a custom part number be assigned, which will also include the date code of manufacture.

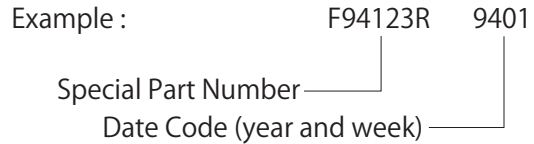

11. Accessories Definition Table

When ordering a rotary solenoid, the correct number for the angle of rotation, direction of rotation and accessories needs to be determined from the following table.

Table 3

Accessories	Clockwise Rotation(RH)					Counter Clockwise Rotation(LH)				
	25°	35°	45°	67.5°	95°	25°	35°	45°	67.5°	95°
A	070	071	072	073	074	075	076	077	078	079
A T	100	101	102	103	104	105	106	107	108	109
A T R	110	111	112	113	114	115	116	117	118	119
A D	120	121	122	123	124	125	126	127	128	129
A D R	130	131	132	133	134	135	136	137	138	139
A R	140	141	142	143	144	145	146	147	148	149
T	170	171	172	173	174	175	176	177	178	179
T R	180	181	182	183	184	185	186	187	188	189
B	220	221	222	223	224	225	226	227	228	229
A B	230	231	232	233	234	235	236	237	238	239
A B T	260	261	262	263	264	265	266	267	268	269
A B T R	280	281	282	283	284	285	286	287	288	289
A B D	290	291	292	293	294	295	296	297	298	299
A B D R	300	301	302	303	304	305	306	307	308	309
A B R	310	311	312	313	314	315	316	317	318	319
B T	340	341	342	343	344	345	346	347	348	349
B T R	360	361	362	363	364	365	366	367	368	369
B D	370	371	372	373	374	375	376	377	378	379
B D R	380	381	382	383	384	385	386	387	388	389
B R	390	391	392	393	394	395	396	397	398	399

SIZE301 ROTARY SOLENOID

UNIT : mm

SHOWN DE-ENERGIZED, RIGHT HAND ROTATION



WEIGHT(ABD&R): 56g

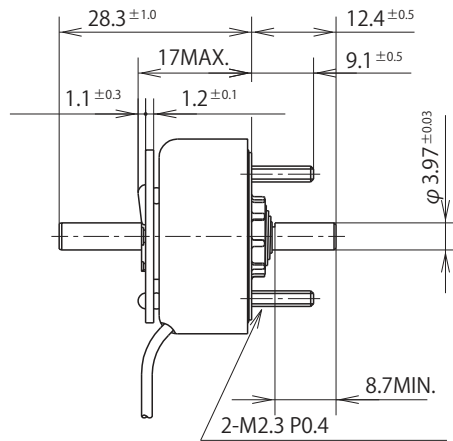

WITH A, B & R

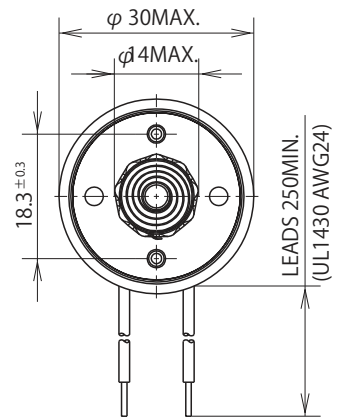

1/2 ROTATION ANGLE ±3° TO LEFT OF CENTER FOR R.H.ROTATION, RIGHT OF CENTER FOR L.H.ROTATION.

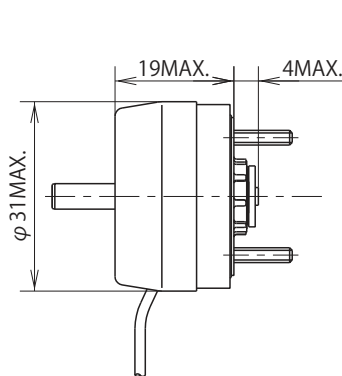

WITH A, D & R

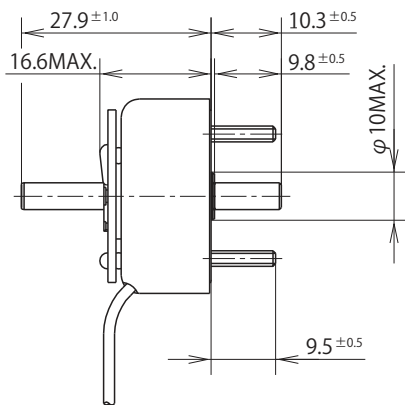

WITH A & B

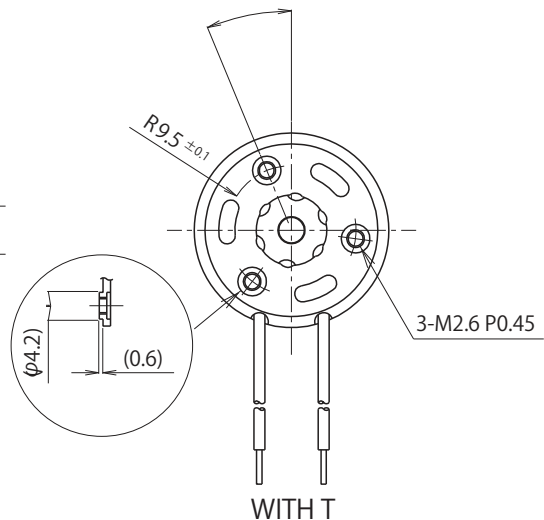

COIL DATA

Heat sink : 90 × 90 × 3mm aluminum

Return spring torque : 0.0055~0.009 N · m

duty cycle = $\frac{\text{"on" time}}{\text{"on" time} + \text{"off" time}} \times 100\%$	100% continuous	75% or less	50% or less	25% or less	10% or less	
MAX. "on" time in seconds	∞	105	100	36	7	
watts at 20°C	7	9.3	14	28	70	
ampere-turns at 20°C	425	490	602	849	1350	
gross starting torque at 20°C (N · m)	25°	0.022	0.035	0.046	0.069	0.15
	35°	0.017	0.022	0.035	0.058	0.127
	45°	0.012	0.014	0.021	0.035	0.081

AWG no.	resistance $\Omega \pm 10\%$ (at 20°C)	no. turns	volts DC					
26	1.96	231	3.5	4.1	5	7.1	11	
27	3.16	296	4.5	5.1	6.3	8.9	14	
28	5.1	378	5.6	6.5	8	11	18	
29	6.94	423	7.1	8.1	10	14	22	
30	11	530	8.9	10	13	18	28	
31	16.9	649	11	12	16	22	36	
32	28.3	858	14	16	20	28	45	
33	42.8	1036	18	20	25	35	56	
34	69.6	1312	22	26	32	45	71	
35	112	1674	28	32	39	56	89	
36	148	1765	35	41	50	71	112	
37	221	2090	45	51	63	89	142	
38	352	2650	56	65	80	112	178	
39	568	3380	71	81	100	141	224	
40	882	4200	89	102	126	178	283	

SIZE341 ROTARY SOLENOID

UNIT : mm
SHOWN DE-ENERGIZED, RIGHT HAND ROTATION



WEIGHT(ABD&R): 97g

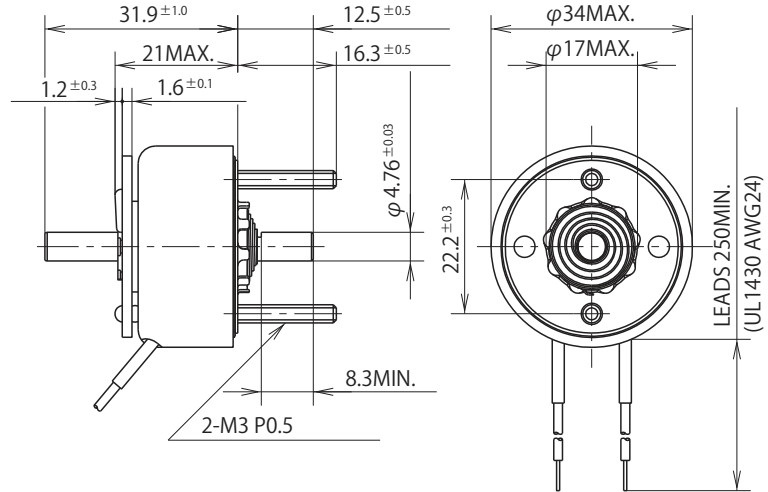

WITH A, B&R

1/2 ROTATION ANGLE ±3° TO LEFT OF CENTER FOR R.H.ROTATION, RIGHT OF CENTER FOR L.H.ROTATION.

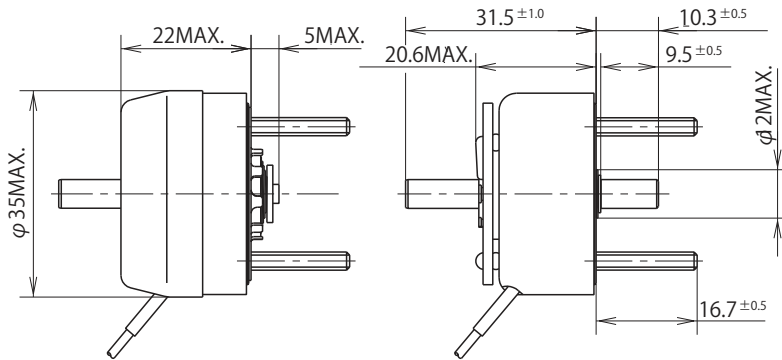

WITH A, D&R

WITH A&B

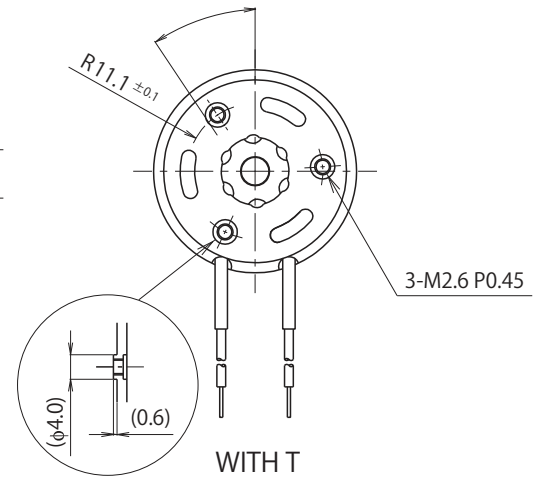

WITH T

COIL DATA

Heat sink : 120 × 120 × 3mm aluminum

Return spring torque : 0.011~0.017 N · m

duty cycle = $\frac{\text{"on" time}}{\text{"on" time} + \text{"off" time}} \times 100\%$		100% continuous	75% or less	50% or less	25% or less	10% or less	
MAX. "on" time in seconds		∞	107	100	36	8	
watts at 20°C		9	12	18	36	90	
ampere-turns at 20°C		535	618	756	1070	1690	
gross starting torque at 20°C (N·m)		25°	0.04	0.052	0.081	0.15	0.31
		35°	0.029	0.04	0.063	0.115	0.23
		45°	0.017	0.022	0.04	0.092	0.16
		67.5°	0.012	0.017	0.022	0.046	0.075
AWG no.	resistance $\Omega \pm 10\%$ (at 20°C)	no. turns	volts DC				
25	1.97	252	4.2	4.8	5.9	8.4	13
26	3.26	328	5.3	6.1	7.5	11	17
27	5.04	405	6.7	7.7	9.4	13	21
28	8.02	510	8.4	9.7	12	17	26
29	12.21	627	10	12	15	21	33
30	19.2	780	13	15	19	26	42
31	31.8	1008	17	19	24	33	53
32	47	1215	21	24	30	42	66
33	75.3	1530	26	31	37	53	84
34	120.5	1900	33	38	47	67	105
35	198	2486	42	48	59	84	133
36	280	2700	53	61	75	106	167
37	426	3350	67	77	94	133	210
38	648	4050	84	97	118	168	264
39	1020	5050	105	122	149	211	333
40	1667	6590	133	153	187	265	419

SIZE401 ROTARY SOLENOID

UNIT : mm

SHOWN DE-ENERGIZED, RIGHT HAND ROTATION



WEIGHT(ABD&R): 200g

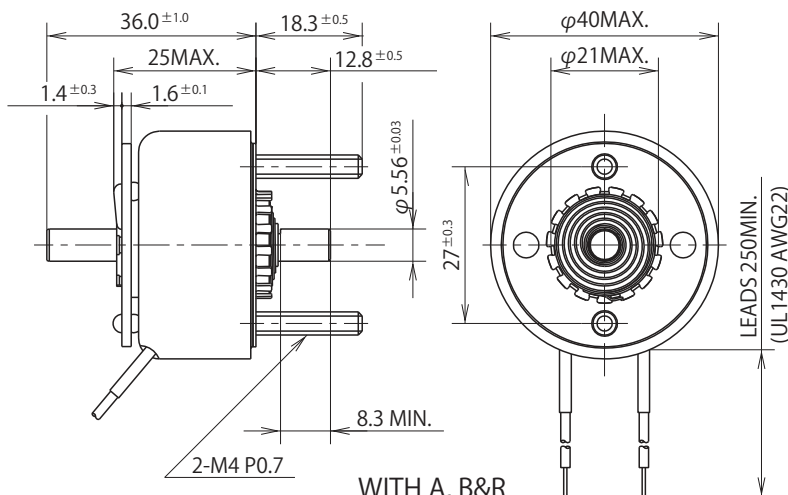

WITH A, B&R

1/2 ROTATION ANGLE ±3° TO LEFT OF CENTER FOR R.H.ROTATION, RIGHT OF CENTER FOR L.H.ROTATION.

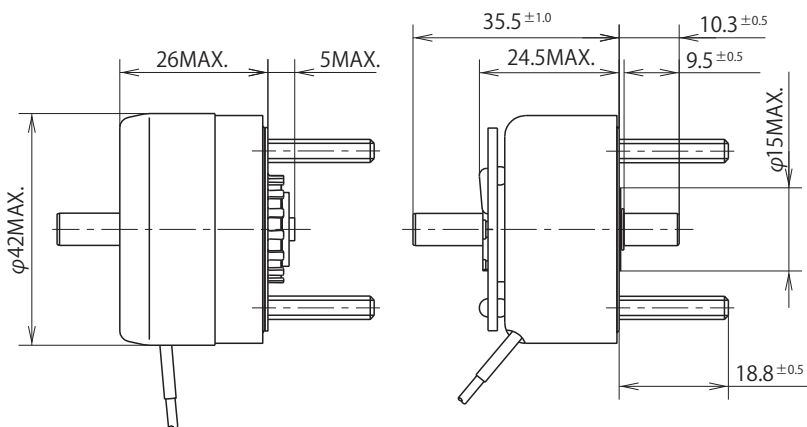

WITH A, D&R

WITH A&B

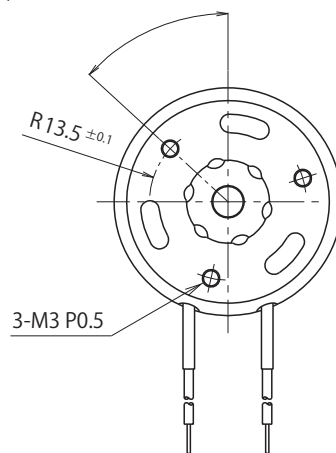

WITH T

COIL DATA

Heat sink : 160 × 160 × 3mm aluminum

Return spring torque : 0.0165~0.024 N · m

duty cycle = $\frac{\text{"on" time}}{\text{"on" time} + \text{"off" time}} \times 100\%$			100% continuous	75% or less	50% or less	25% or less	10% or less
MAX. "on" time in seconds			∞	108	100	36	9
watts at 20°C			12.5	16.5	25	50	125
ampere-turns at 20°C			714	825	1000	1425	2250
gross starting torque at 20°C (N · m)			25°	0.104	0.138	0.195	0.355
			35°	0.069	0.092	0.127	0.23
			45°	0.035	0.058	0.092	0.16
			67.5°	0.022	0.035	0.046	0.092
95°	0.012	0.022	0.035	0.058	0.115		
AWG no.	resistance $\Omega \pm 10\%$ (at 20°C)	no. turns	volts DC				
25	3.5	384	6.6	7.8	9.5	13	21
26	5.67	486	8.4	9.7	12	17	27
27	8.76	600	11	13	16	22	35
28	13.8	748	13	15	18	26	42
29	22.6	975	17	19	23	33	52
30	34.8	1190	21	25	30	42	67
31	56.7	1520	27	31	38	54	85
32	88.3	1908	35	41	49	70	110
33	138	2360	43	50	60	86	138
34	216	2904	53	61	75	106	168
35	351	3725	67	78	95	132	213
36	480	4000	85	98	119	169	268
37	720	4950	105	121	147	210	332
38	1150	6200	132	153	185	264	—
39	1920	8350	166	191	232	332	—
40	3000	10000	210	250	300	—	—

SIZE490 ROTARY SOLENOID

UNIT : mm
SHOWN DE-ENERGIZED, RIGHT HAND ROTATION

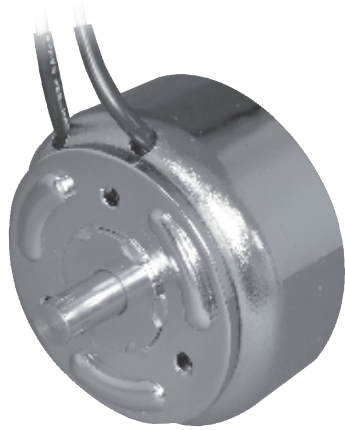

WEIGHT(ABD&R): 250g

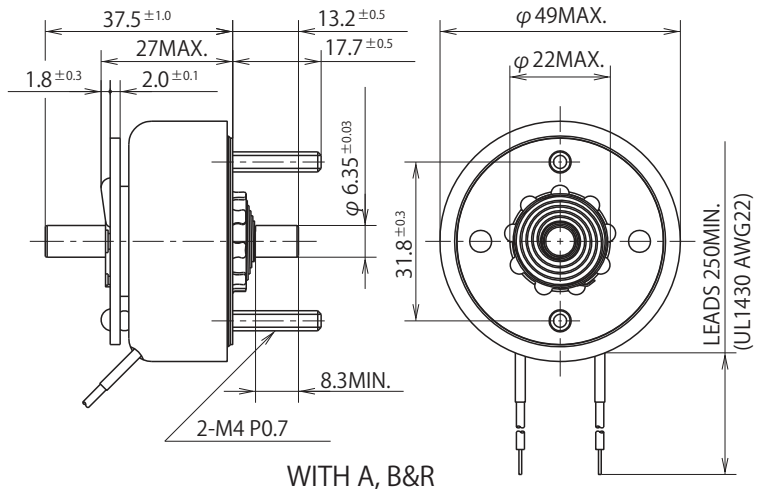

WITH A, B&R

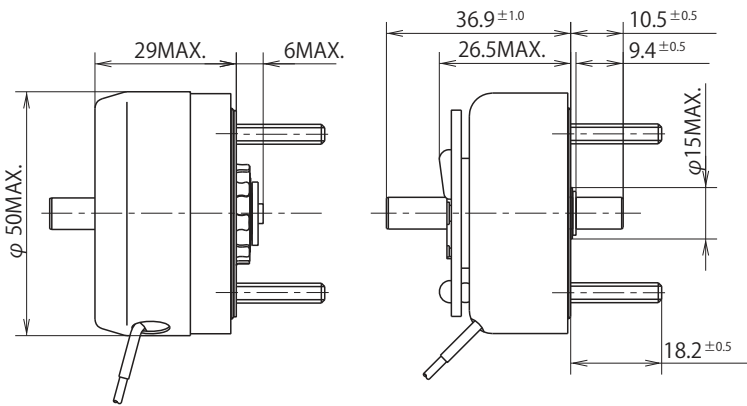

WITH A, D&R

WITH A&B

1/2 ROTATION ANGLE ±3° TO LEFT OF CENTER FOR R.H.ROTATION, RIGHT OF CENTER FOR L.H.ROTATION.

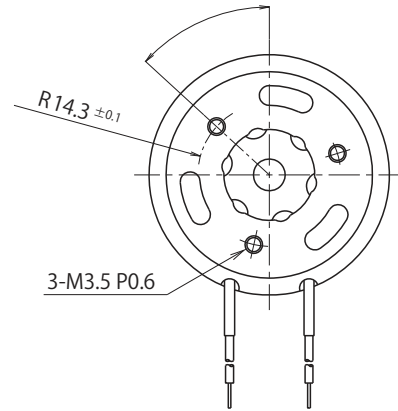

WITH T

COIL DATA

Heat sink : 190 × 190 × 3mm aluminum

Return spring torque : 0.026~0.035 N · m

duty cycle = $\frac{\text{"on" time}}{\text{"on" time} + \text{"off" time}} \times 100\%$			100% continuous	75% or less	50% or less	25% or less	10% or less
MAX. "on" time in seconds			∞	110	100	36	10
watts at 20°C			21	28	42	84	210
ampere-turns at 20°C			842	966	1190	1685	2660
gross starting torque at 20°C (N · m)			25°	0.22	0.3	0.47	1.39
			35°	0.104	0.15	0.24	0.84
			45°	0.081	0.127	0.195	0.725
			67.5°	0.058	0.081	0.127	0.45
			95°	0.022	0.035	0.046	0.098
AWG no.	resistance Ω ±10%(at 20°C)	no. turns	volts DC				
24	3.2	360	7.6	8.7	11	15	24
25	4.91	440	9.5	11	13	19	30
26	7.72	550	12	14	17	24	38
27	11.1	636	15	17	21	30	48
28	18.8	840	19	22	27	38	60
29	30.5	1088	24	28	34	48	76
30	44.9	1275	30	34	43	60	95
31	70.9	1596	38	43	54	76	120
32	109	1974	48	56	67	95	150
33	175	2496	60	69	85	120	190
34	270	3042	76	87	107	151	239
35	414	3600	95	109	134	190	301
36	610	4200	122	140	173	245	386
37	940	5200	151	174	213	301	—
38	1560	6820	190	219	268	379	—

SIZE491 ROTARY SOLENOID

UNIT : mm

SHOWN DE-ENERGIZED, RIGHT HAND ROTATION



WEIGHT(ABD&R): 330g

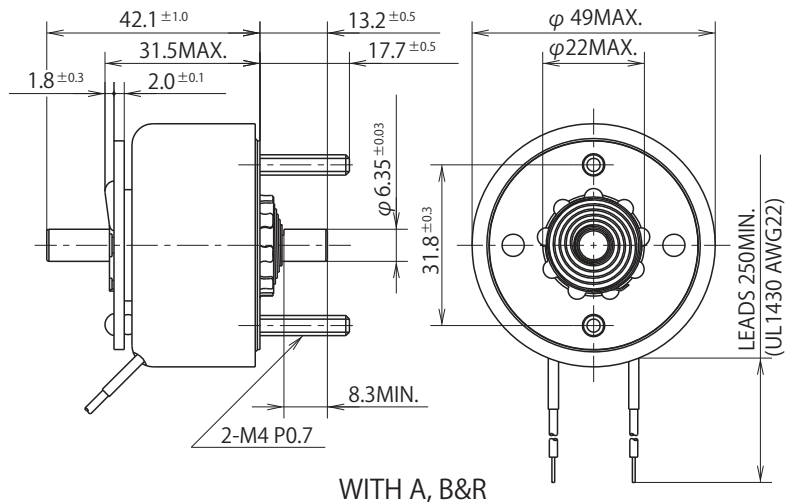

WITH A, B&R

1/2 ROTATION ANGLE ±3° TO LEFT OF CENTER FOR R.H.ROTATION, RIGHT OF CENTER FOR L.H.ROTATION.

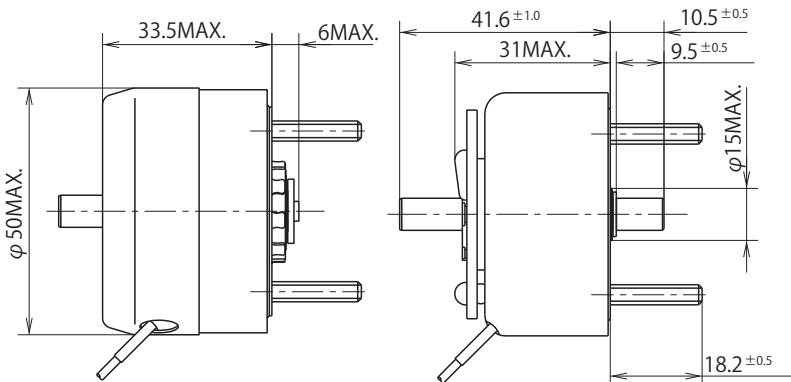

WITH A, D&R

WITH A&B

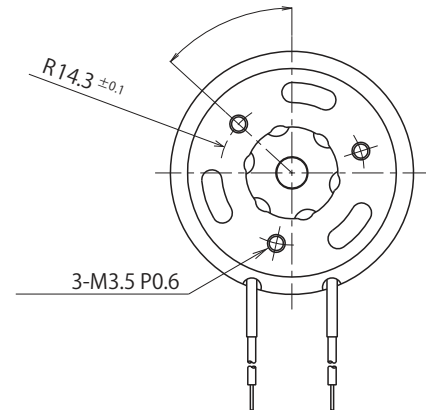

WITH T

COIL DATA

Heat sink : 190 × 190 × 3mm aluminum

Return spring torque : 0.026~0.035 N · m

duty cycle = $\frac{\text{"on" time}}{\text{"on" time} + \text{"off" time}} \times 100\%$	100% continuous	75% or less	50% or less	25% or less	10% or less	
MAX. "on" time in seconds	∞	110	100	36	10	
watts at 20°C	21	28	42	84	210	
ampere-turns at 20°C	1015	1172	1440	2030	3210	
gross starting torque at 20°C (N·m)	25°	0.32	0.44	0.66	1.04	1.54
	35°	0.16	0.22	0.35	0.61	0.96
	45°	0.13	0.18	0.28	0.52	0.79
	67.5°	0.09	0.12	0.17	0.31	0.52
	95°	0.04	0.05	0.08	0.12	0.24

AWG no.	resistance Ω ±10%(at 20°C)	no. turns	volts DC				
21	1.00	228	4.5	5.2	6.4	8.9	14.1
22	1.68	301	5.7	6.6	8.1	11.4	17.9
23	2.70	384	7.2	8.3	10.1	14.3	23.0
24	4.30	486	9.0	10.4	12.7	18.0	28.0
25	6.66	590	11.5	13.2	16.2	23.0	36.0
26	10.3	737	14.0	16.1	20.0	28.0	44.0
27	15.7	900	17.7	20.4	25.0	35.0	56.0
28	26.6	1190	23	27	32	45	72
29	38.0	1380	28	32	40	56	89
30	62.1	1768	36	41	51	71	113
31	96.1	2166	45	52	64	90	143
32	157	2816	57	66	80	113	179
33	241	3432	71	82	101	143	226
34	364	4108	90	104	128	180	285
35	566	4920	117	136	166	234	370
36	910	6340	146	168	207	292	462
37	1224	6800	183	211	260	366	—

SIZE590 ROTARY SOLENOID

UNIT : mm
SHOWN DE-ENERGIZED, RIGHT HAND ROTATION



WEIGHT(ABD&R): 506g

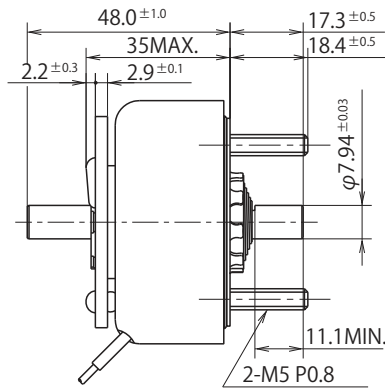

WITH A, B&R

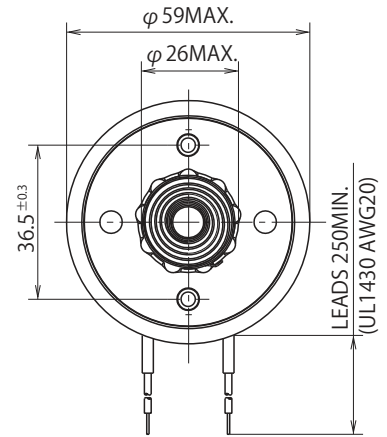

1/2 ROTATION ANGLE ±3° TO LEFT OF CENTER FOR R.H.ROTATION, RIGHT OF CENTER FOR L.H.ROTATION.

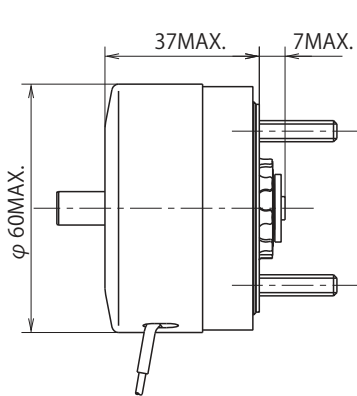

WITH A, D&R

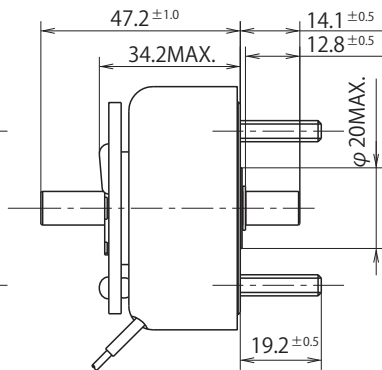

WITH A&B

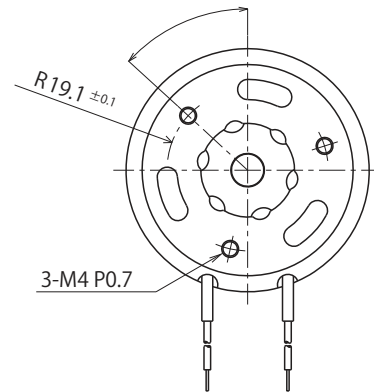

WITH T

COIL DATA

Heat sink : 310 × 310 × 3mm aluminum

Return spring torque : 0.045~0.065 N · m

duty cycle = $\frac{\text{"on" time}}{\text{"on" time} + \text{"off" time}} \times 100\%$			100% continuous	75% or less	50% or less	25% or less	10% or less
MAX. "on" time in seconds			∞	115	87	36	13
watts at 20°C			29	38.5	58	116	290
ampere-turns at 20°C			1240	1440	1760	2490	3920
gross starting torque at 20°C (N · m)			25°	0.53	0.69	1.02	1.8
			35°	0.39	0.53	0.75	1.38
			45°	0.195	0.276	0.4	0.75
			67.5°	0.184	0.24	0.355	0.65
			95°	0.103	0.138	0.195	0.38
AWG no.	resistance $\Omega \pm 10\%$ (at 20°C)	no. turns	volts DC				
22	2.23	336	8.3	9.6	12	16	26
23	3.6	432	10	12	15	21	33
24	5.24	500	13	15	18	26	41
25	9.51	708	16	19	23	33	52
26	14.4	858	21	24	29	41	66
27	23.7	1110	26	30	37	52	83
28	38.2	1411	33	38	47	66	104
29	54.7	1638	41	48	59	83	131
30	93.7	2184	52	61	74	104	165
31	143	2645	66	76	93	131	207
32	223	3328	83	96	117	165	261
33	338	4004	104	121	147	208	329
34	550	5088	131	152	185	262	—
35	790	5860	165	192	233	330	—
36	1233	7260	208	242	294	—	—

SIZE591 ROTARY SOLENOID

UNIT : mm

SHOWN DE-ENERGIZED, RIGHT HAND ROTATION



WEIGHT(ABD&R): 615g

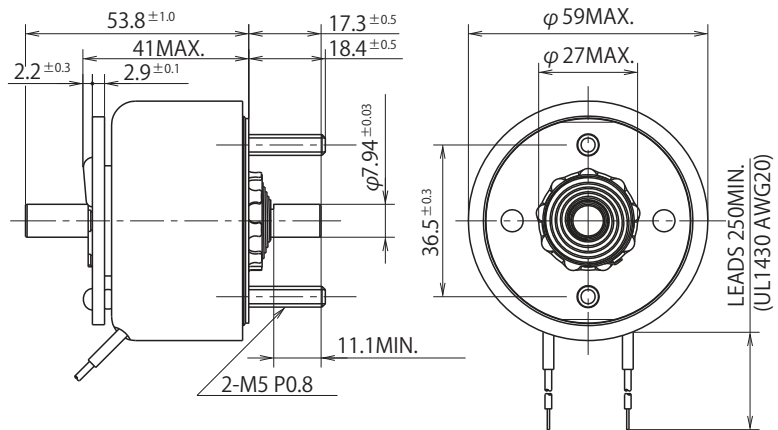

WITH A, B&R

1/2 ROTATION ANGLE ±3° TO LEFT OF CENTER FOR R.H.ROTATION, RIGHT OF CENTER FOR L.H.ROTATION.

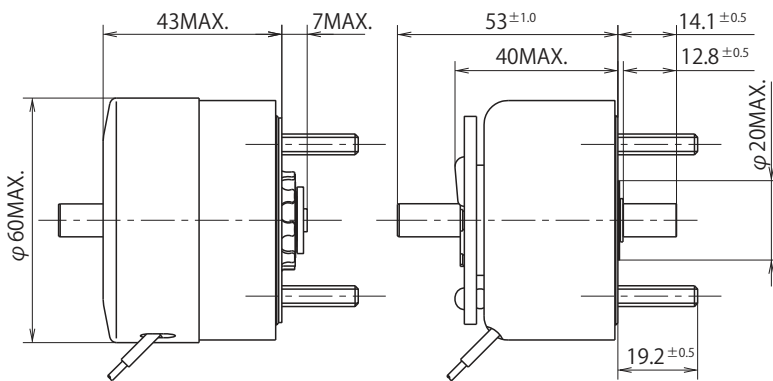

WITH A, D&R

WITH A&B

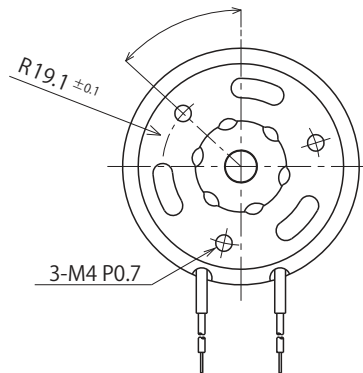

WITH T

COIL DATA

Heat sink : 310 × 310 × 3mm aluminum

Return spring torque : 0.045~0.065 N · m

duty cycle = $\frac{\text{"on" time}}{\text{"on" time} + \text{"off" time}} \times 100\%$		100% continuous	75% or less	50% or less	25% or less	10% or less	
MAX. "on" time in seconds		∞	95	87	36	13	
watts at 20°C		32	43	64	128	320	
ampere-turns at 20°C		1480	1710	2080	2940	4620	
gross starting torque at 20°C (N · m)	25°	0.72	0.92	1.33	2.33	3.45	
	35°	0.53	0.69	1.03	1.7	2.27	
	45°	0.28	0.38	0.55	0.94	1.36	
	67.5°	0.25	0.33	0.48	0.78	1.07	
	95°	0.14	0.19	0.27	0.47	0.64	
AWG no.	resistance Ω ± 10% (at 20°C)	no. turns	volts DC				
20	1.23	295	6.2	7.1	8.7	12.3	19.3
21	1.75	340	7.6	8.8	10.7	15.1	24
22	2.79	446	9.3	10.7	13	18.4	29
23	4.54	567	11.9	13.7	16.7	24	37
24	6.93	690	14.9	17.2	21	30	46
25	12.5	910	20.0	24	29	40	63
26	18.4	1120	24	28	34	48	76
27	33.4	1500	33	38	46	65	103
28	46.3	1750	39	45	55	78	122
29	74.5	2232	49	57	69	98	154
30	125.5	2940	63	73	89	126	197
31	199	3611	82	94	115	162	255
32	302	4350	103	119	144	204	321
33	417	5010	123	142	173	245	385

SIZE700 ROTARY SOLENOID

UNIT : mm
SHOWN DE-ENERGIZED, RIGHT HAND ROTATION



WEIGHT(ABD&R): 1,013g

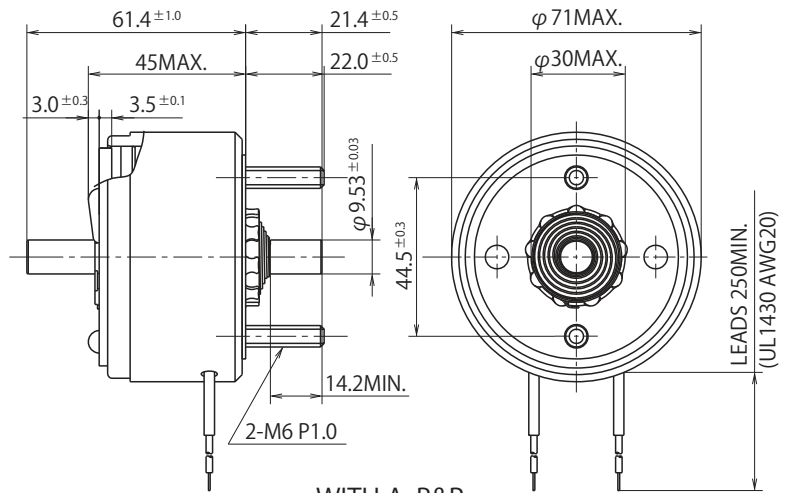

WITH A, B&R

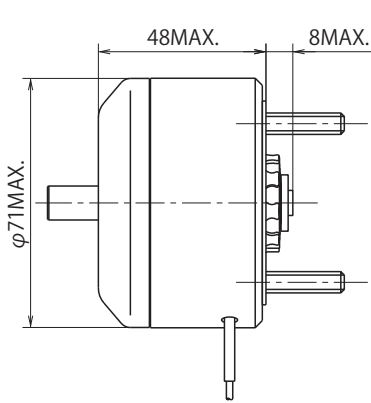

WITH A, D&R

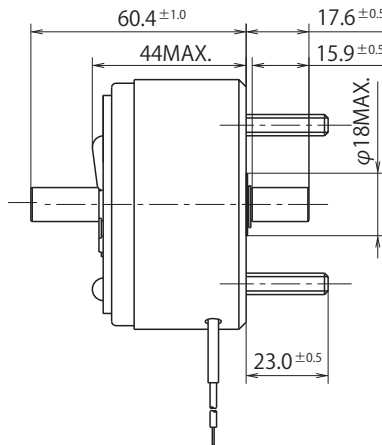

WITH A&B

1/2 ROTATION ANGLE ±3° TO LEFT OF CENTER FOR R.H. ROTATION, RIGHT OF CENTER FOR L.H. ROTATION.

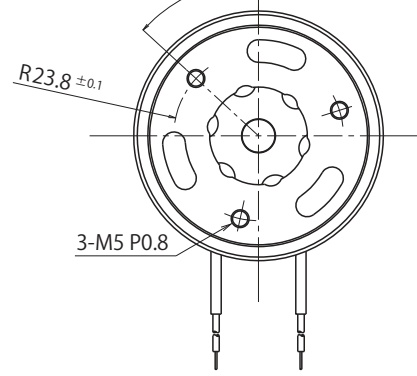

WITH T

COIL DATA

Heat sink : 390 × 390 × 3mm aluminum

Return spring torque : 0.075~0.105 N · m

duty cycle = $\frac{\text{"on" time}}{\text{"on" time} + \text{"off" time}} \times 100\%$		100% continuous	75% or less	50% or less	25% or less	10% or less	
MAX. "on" time in seconds		∞	112	80	37	16	
watts at 20°C		35	46.5	70	140	350	
ampere-turns at 20°C		1570	1800	2230	3150	5000	
gross starting torque at 20°C (N · m)		25°	1.27	2.12	2.74	3.8	4.9
		35°	0.69	0.99	1.38	2.53	4.37
		45°	0.58	0.78	1.0	1.88	3.42
		67.5°	0.288	0.355	0.59	1.12	2.01
		95°	0.178	0.3	0.4	0.735	1.21
AWG no.	resistance Ω ±10% (at 20°C)	no. turns	volts DC				
20	1.88	368	8	9.3	11	16	26
21	3.01	468	10	11	14	20	32
22	4.82	580	13	15	18	26	41
23	8.1	780	16	19	23	33	52
24	12.3	949	20	23	29	41	65
25	19	1148	26	30	37	52	83
26	30.8	1472	33	38	46	66	105
27	48.8	1854	41	47	59	83	132
28	81.1	2436	52	60	75	105	166
29	121	2944	64	74	92	130	206
30	190	3650	82	94	118	166	264
31	275	4175	104	119	147	209	331
32	440	5792	119	137	170	240	—
33	735	7000	165	191	235	331	—
34	995	7600	204	239	288	—	—

SIZE870 ROTARY SOLENOID

UNIT : mm

SHOWN DE-ENERGIZED, RIGHT HAND ROTATION



WEIGHT(ABD&R): 1,885g

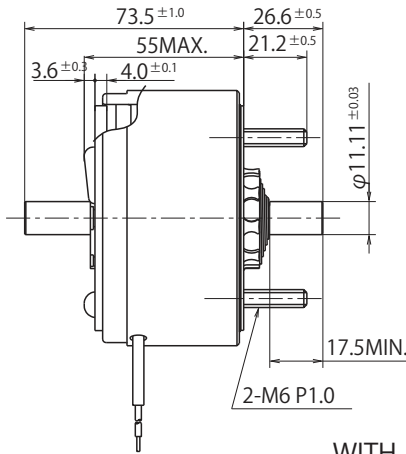

WITH A, B&R

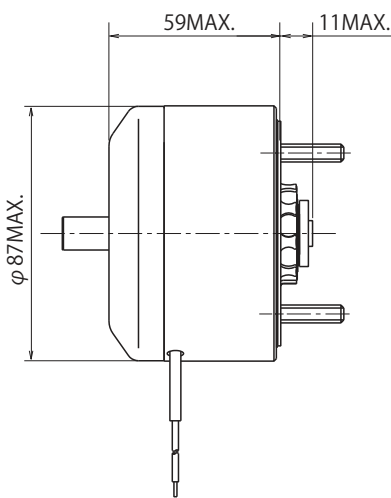
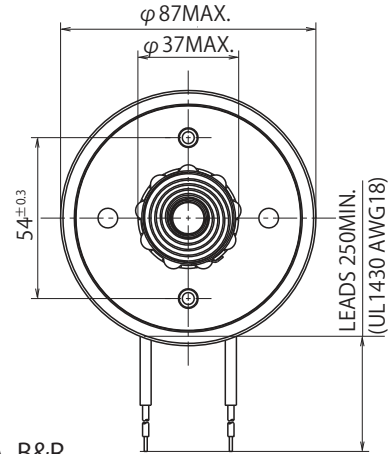

WITH A, D&R

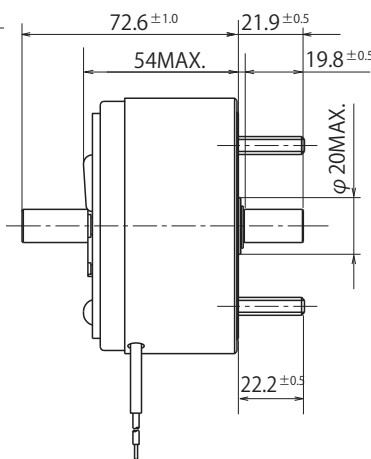

WITH A&B

1/2 ROTATION ANGLE ±3° TO LEFT OF CENTER FOR R.H.ROTATION, RIGHT OF CENTER FOR L.H.ROTATION.

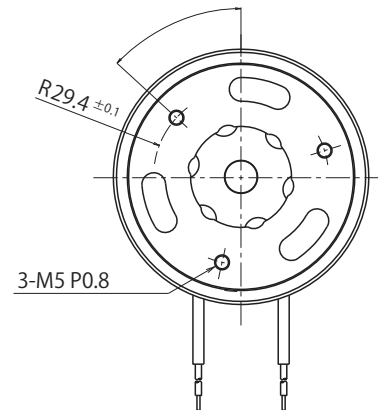

WITH T

COIL DATA

Heat sink : 520 × 520 × 3mm aluminum

Return spring torque : 0.09~0.14 N · m

duty cycle = $\frac{\text{"on" time}}{\text{"on" time} + \text{"off" time}} \times 100\%$		100% continuous	75% or less	50% or less	25% or less	10% or less	
MAX. "on" time in seconds		∞	85	72	43	20	
watts at 20°C		41	54.5	82	164	410	
ampere-turns at 20°C		1910	2190	2750	3810	5950	
gross starting torque at 20°C (N · m)		25°	1.84	2.65	4.25	6.9	11.3
		35°	1.38	1.84	2.76	4.5	7.35
		45°	1.15	1.5	2.2	3.9	6.2
		67.5°	0.48	0.69	1.15	1.95	3.34
95°	0.4	0.48	0.7	1.15	1.95		
AWG no.	resistance $\Omega \pm 10\%$ (at 20°C)	no. turns	volts DC				
18	1.47	368	7.6	8.7	11	15	24
19	2.3	459	9.6	11	14	19	30
20	3.64	580	12	14	17	24	37
21	5.57	704	15	17	22	30	47
22	9.5	936	19	22	28	39	60
23	14.3	1134	24	28	35	48	75
24	23.3	1456	30	35	44	61	95
25	37.1	1836	39	44	56	77	120
26	58.6	2300	49	56	70	97	152
27	89.8	2816	61	70	88	121	189
28	139	3456	76	88	111	153	239
29	227	4480	98	111	138	193	300
30	376	5792	124	143	177	248	387
31	515	6600	148	170	212	297	—
32	785	7850	188	220	275	385	—
33	1130	9050	237	271	339	—	—

SIZE874 ROTARY SOLENOID

UNIT : mm
SHOWN DE-ENERGIZED, RIGHT HAND ROTATION



WEIGHT(ABD&R): 3,056g

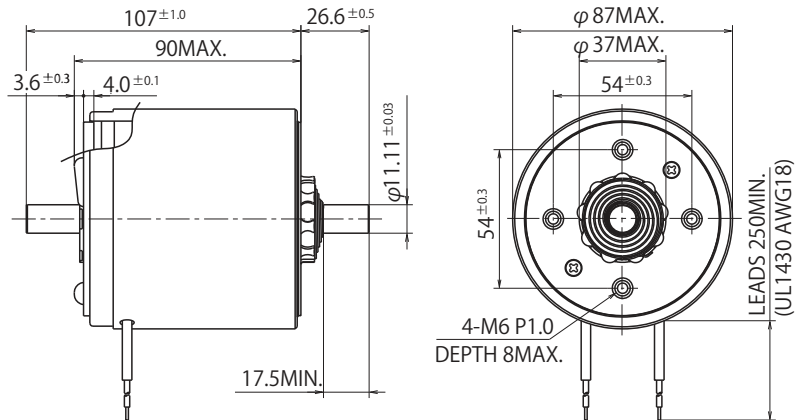

WITH A, B&R

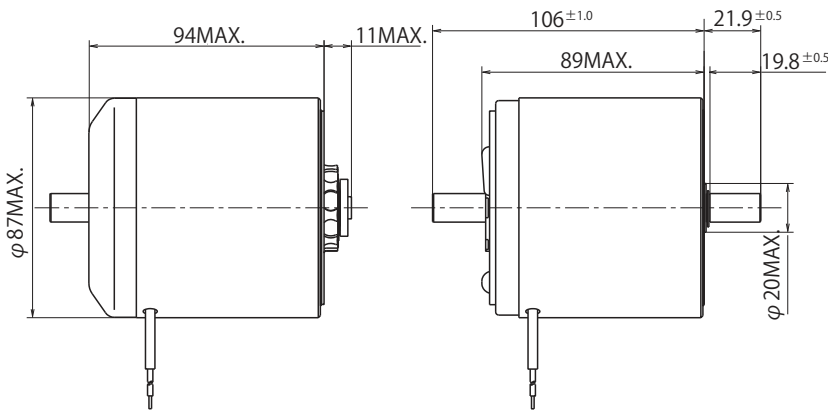

WITH A, D&R

WITH A&B

1/2 ROTATION ANGLE ±3° TO LEFT OF CENTER FOR R.H.ROTATION, RIGHT OF CENTER FOR L.H.ROTATION.

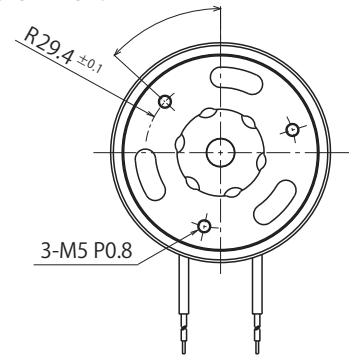

WITH T

COIL DATA

Heat sink : 520 × 520 × 3mm aluminum

Return spring torque : 0.09~0.14 N · m

duty cycle = $\frac{\text{"on" time}}{\text{"on" time} + \text{"off" time}} \times 100\%$			100% continuous	75% or less	50% or less	25% or less	10% or less
MAX. "on" time in seconds			∞	85	72	43	20
watts at 20°C			41	54.5	82	164	410
ampere-turns at 20°C			2590	2990	3663	5180	8190
gross starting torque at 20°C (N · m)			25°	3.6	4.7	6.5	10
			35°	2.4	3.1	4.2	6.4
			45°	2.0	2.6	3.6	5.5
			67.5°	1.0	1.3	1.8	2.9
			95°	0.66	0.82	1.1	1.7
AWG no.	resistance Ω ±10%(at 20°C)	no. turns	volts DC				
18	2.54	630	10	12	15	21	33
19	4.15	828	13	15	18	26	41
20	6.38	1047	16	18	22	32	50
21	11.14	1408	20	24	29	41	65
22	16.8	1723	25	29	36	51	80
23	25.8	2046	33	38	46	65	103
24	42.5	2711	41	47	57	81	128
25	66.3	3279	52	60	74	105	166
26	105	4151	66	76	93	131	207
27	165	5190	82	95	116	165	260
28	261	6500	104	120	147	208	329
29	422	8340	131	151	185	262	—
30	664	10230	168	194	238	336	—
31	968	12410	202	233	286	—	—
32	1520	15200	259	299	366	—	—

CHARACTERISTICS TABLES FOR ROTARY SOLENOID

PERFORMANCE CURVES ARE AT 20°C
NO LOAD(RETURN SPRING ONLY).

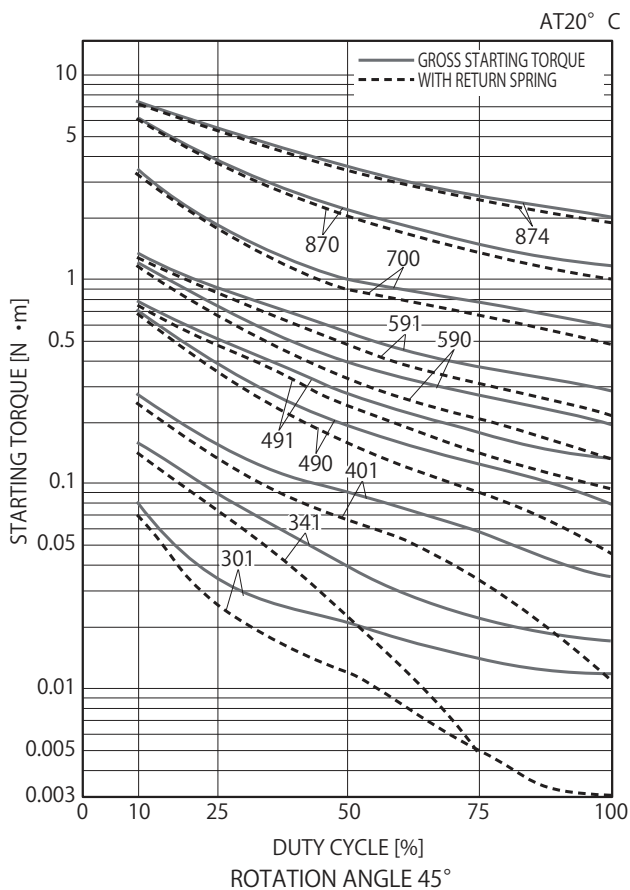
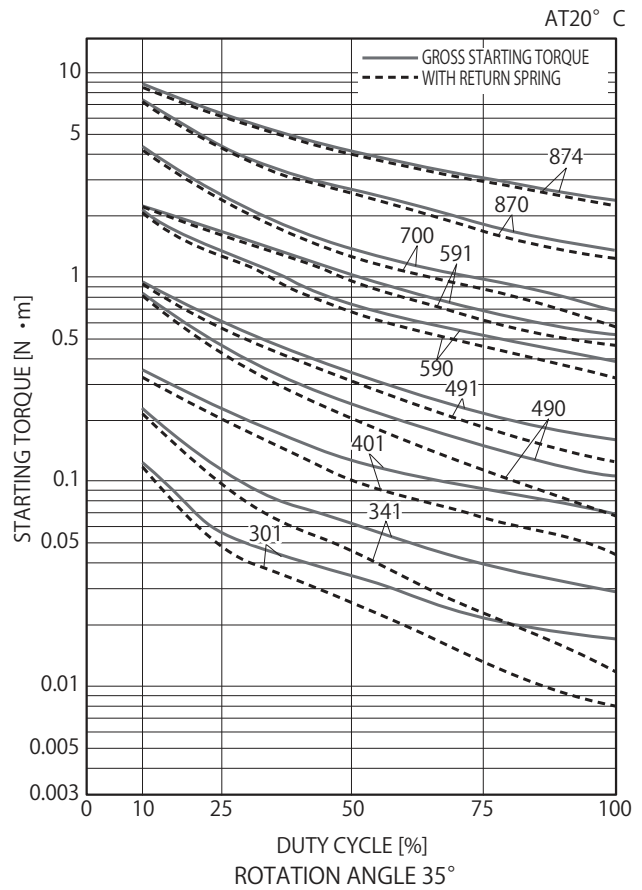
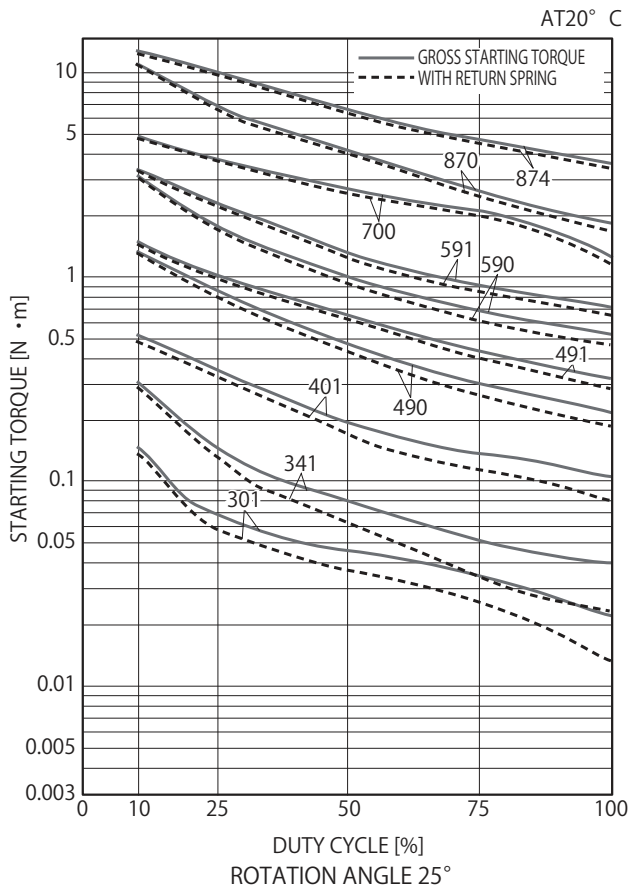

CHARACTERISTICS TABLES FOR ROTARY SOLENOID

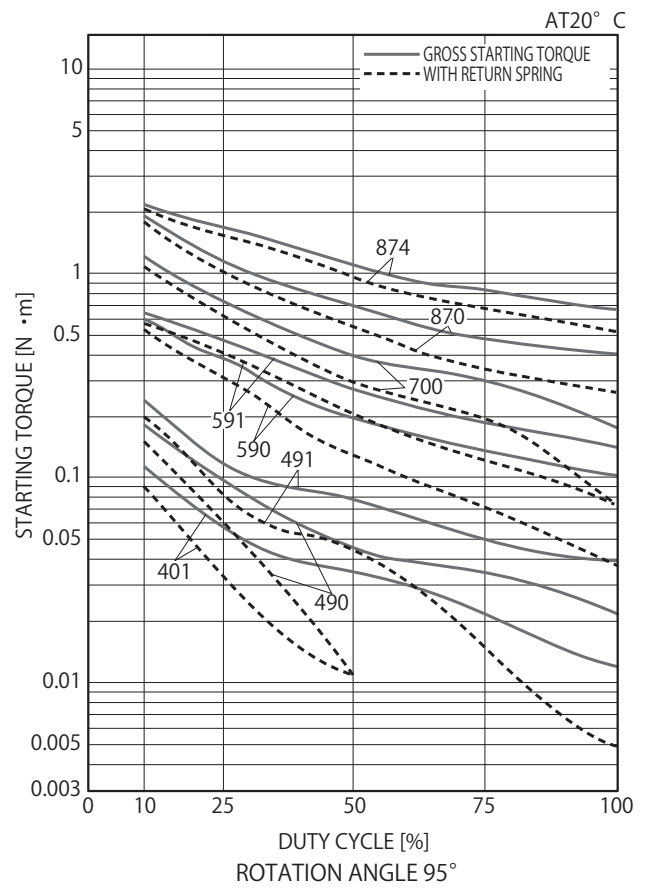
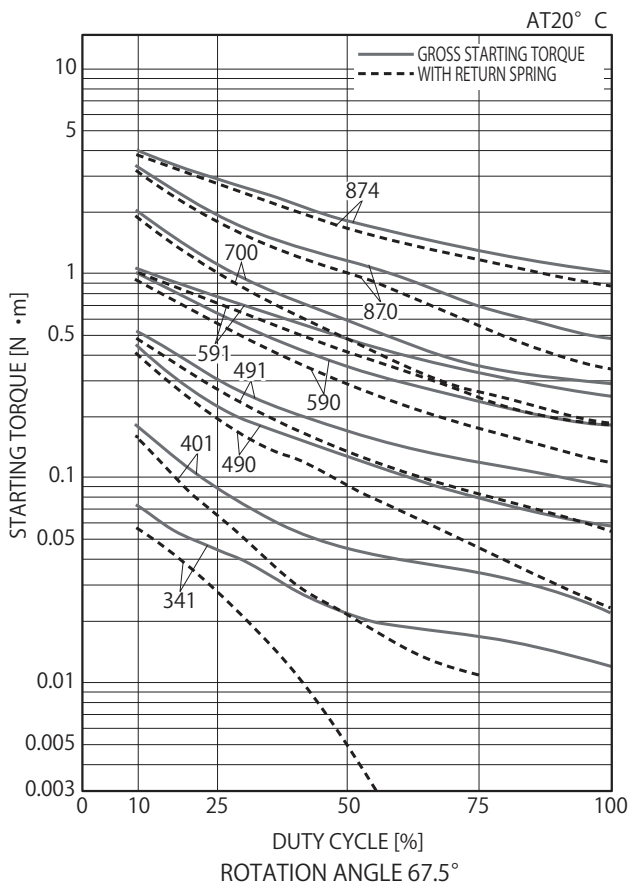

ROTARY SOLENOID AMPERE TURN v.s. GROSS STARTING TORQUE

PERFORMANCE CURVES
ARE AT 20°C

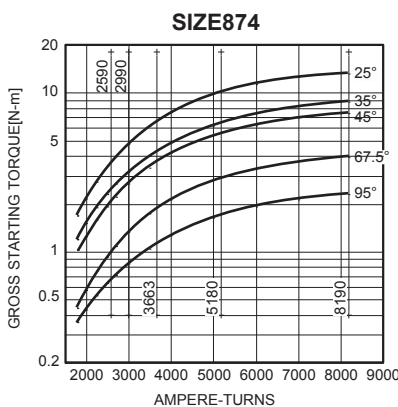
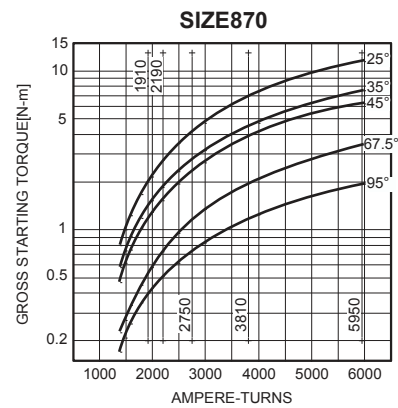
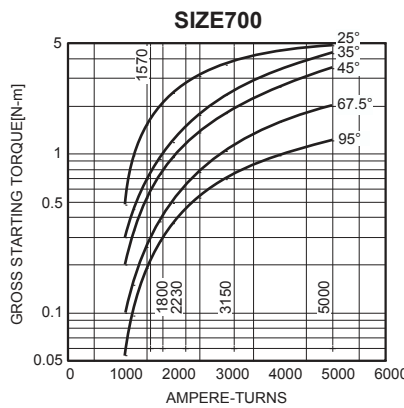
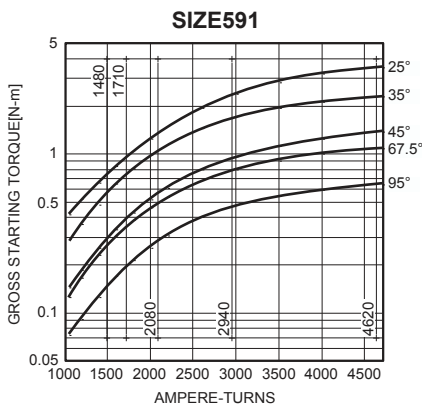
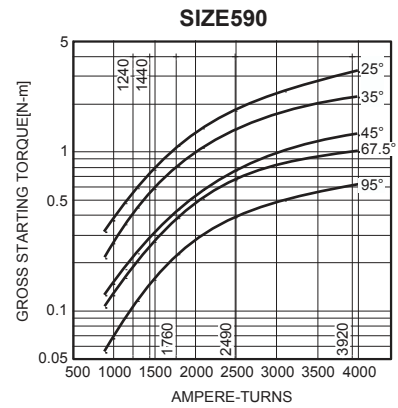
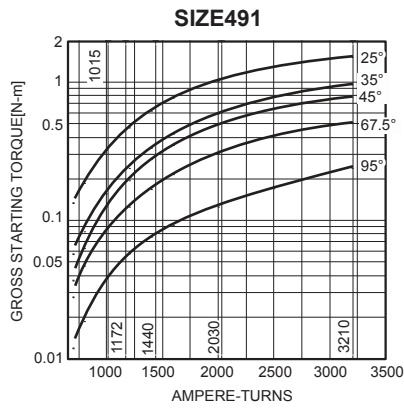
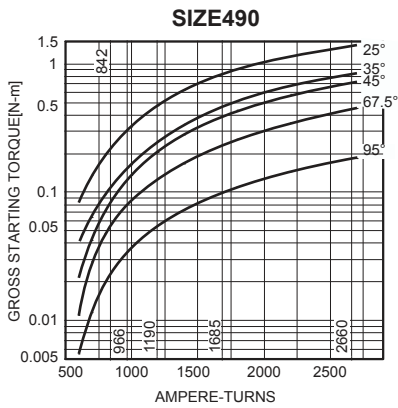
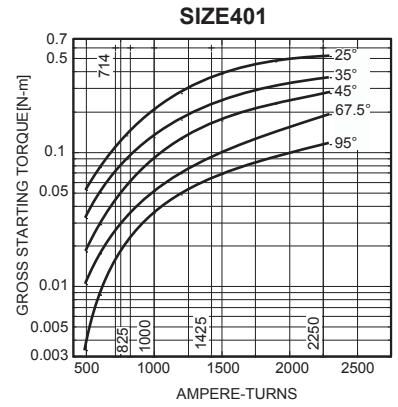
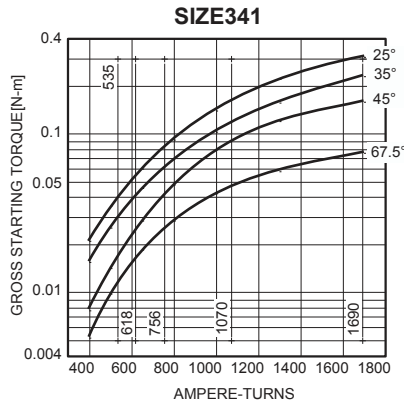
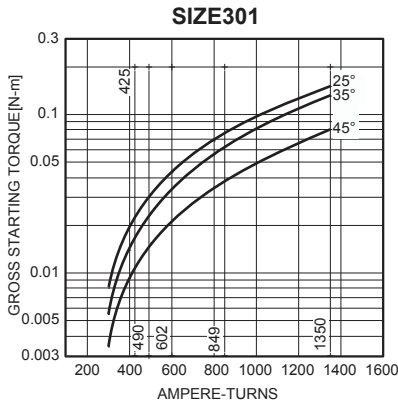

ROTARY SOLENOID AMPERE-TURN v.s. RESPONSE TIME

PERFORMANCE CURVES ARE AT 20°C
NO LOAD(RETURN SPRING ONLY).

Rotary Solenoids

SIZE301

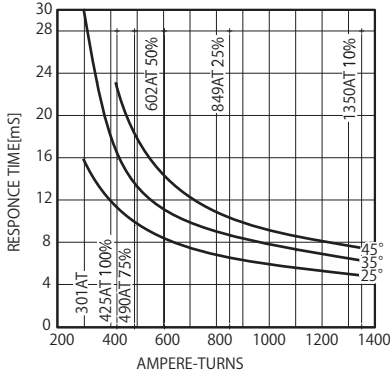

SIZE341

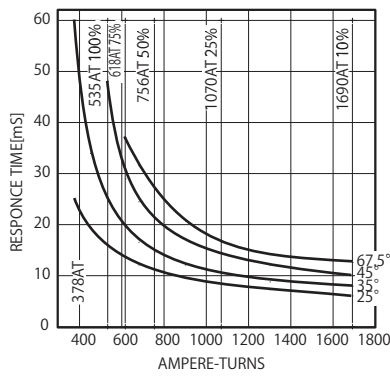

SIZE401

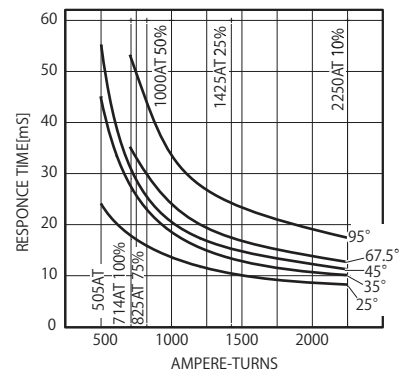

SIZE490

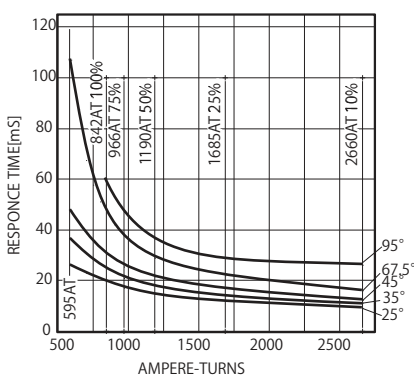

SIZE491

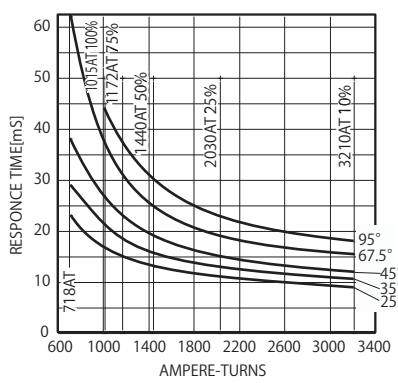

SIZE590

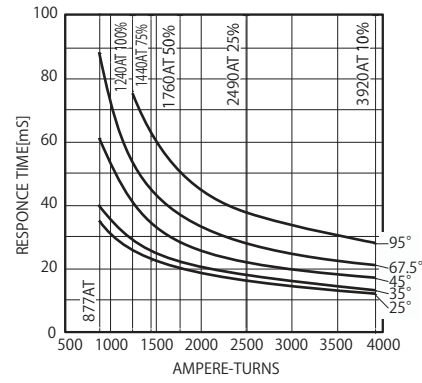

SIZE591

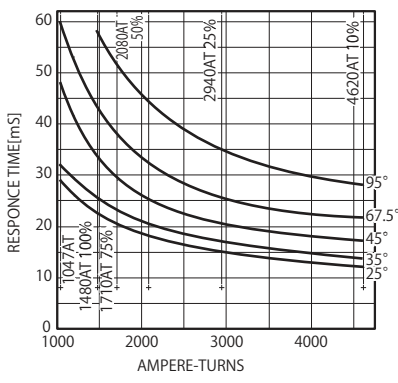

SIZE700

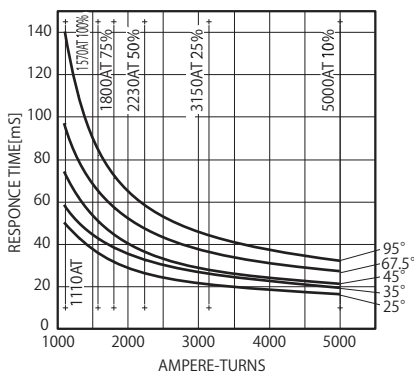

SIZE870

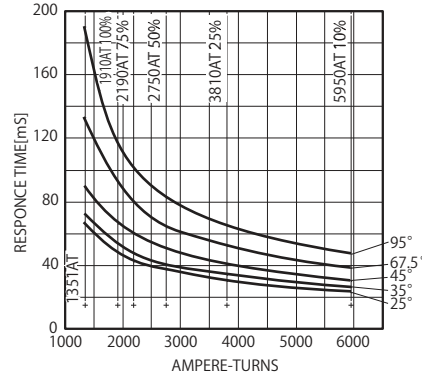

SIZE874

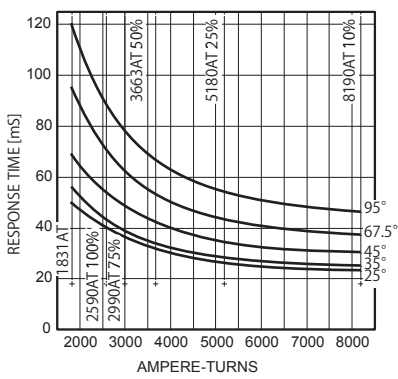

勝特力電材超市-龍山店 886-3-5773766
 勝特力電材超市-光復店 886-3-5729570
 勝特力電子(上海) 86-21-34970699
 勝特力電子(深圳) 86-755-83298787
<http://www.100y.com.tw>