

CONTACT RATING

MK2PI (2PDT)	AC 250V/30VDC	10A
MK3P5I(3PDT)	AC 250V/30VDC	10A

DIMENSIONS(mm)

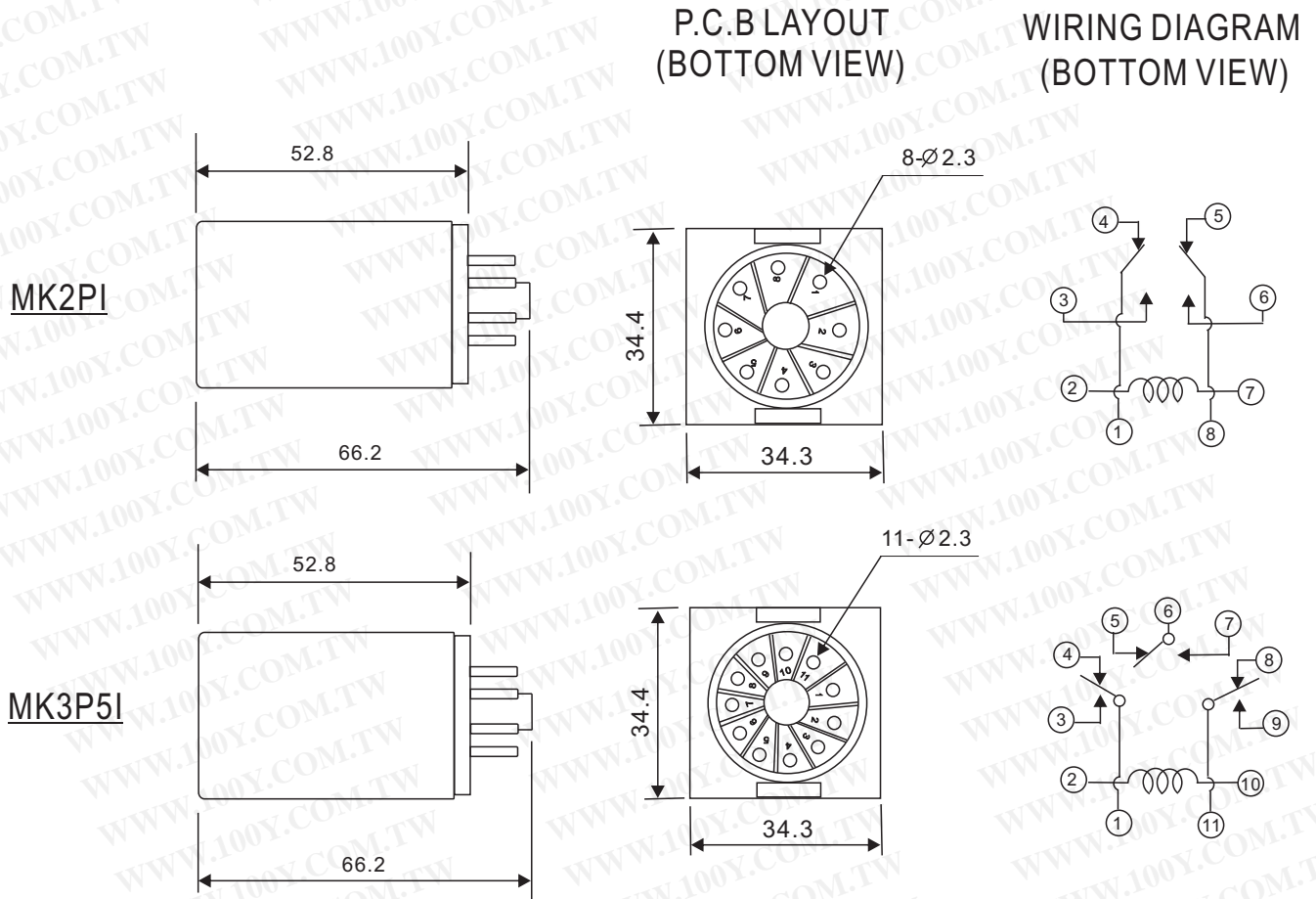

GENERAL DATA

Insulation Resistance	500 MΩ Min. (DC 500V)
Dielectric Strength	1,000 VAC, 50/60Hz between contact.
	1,500 VAC, 50/60Hz between all elements.
Contact Material	Ag Alloy.
Contact Resistance	50 milliohms max. (initial value)
Shock Resistance	Malfunction: 10G(11ms) ; Destructive: 100G(6ms)
Vibration Resistance	Malfunction: 10 to 55 Hz. at Double Amplitude of 1.5 mm
	Destructive: 10 to 55 Hz. at Double Amplitude of 1.5 mm
Operation Time	15 ms max.
Release Time	10 ms max.
Temperature Range	- 40°C ~ + 55°C
Expected Life	With operation rate 30/min.
	Mechanical - 10,000,000 operations min.
	Electrical - 100,000 operations min. at rated load.
Weight	MK2PI Type : 70 grams, MK3P5I Type : 80 grams