

DC SOLID STATE RELAY

KG1005D
KG1010D
KG1025D
KG1040D
KG1050D
KG1075D

KG SERIES



SPECIFICATIONS

MODEL NO.	CONTROL VOLTAGE RANGE	MUST TURN OFF VOLTAGE	INPUT IMPEDANCE	MAX LOAD CURRENT	LOAD VOLTAGE RANGE	MIN BLOCKING VOLTAGE	MAX OFF-STATE LEAKAGE	FREQUENCY RANGE	MAX 1-CYCLE PEAK SURGE
KG1005D	3 TO 32 VDC	MAX 1.0 VDC	1.5 Kohm	5A	5-120VDC	140VDC	LESS 3 mA	47-70HZ	15A
KG1010D	3 TO 32 VDC	MAX 1.0 VDC	1.5 Kohm	10A	5-120VDC	140VDC	LESS 5 mA	47-70HZ	30A
KG1025D	3 TO 32 VDC	MAX 1.0 VDC	1.5 Kohm	25A	5-120VDC	140VDC	LESS 7 mA	47-70HZ	100A
KG1040D	3 TO 32 VDC	MAX 1.0 VDC	1.5 Kohm	40A	5-120VDC	140VDC	LESS 7 mA	47-70HZ	120A
KG1050D	3 TO 32 VDC	MAX 1.0 VDC	1.5 Kohm	50A	5-120VDC	140VDC	LESS 7 mA	47-70HZ	200A
KG1075D	3 TO 32 VDC	MAX 1.0 VDC	1.5 Kohm	75A	5-120VDC	140VDC	LESS 7 mA	47-70HZ	225A

MODEL NO.	MAX OFF STATE dv/dt	MAX ON-STATE VOLTAGE DROP	ISOLATE IMPEDENCE	DIELECTRIC STRENGTH INPUT-OUTPUT	DIELECTRIC STRENGTH INPUT-OUTPUT-CASE	TURN ON TIME	TURN OFF TIME	CAPACITANCE IN-OUT	WEIGHT (g)
KG1005D	200 V/ μ SEC	2.0Vrms	10^9 ohm	4000 VACrms	4000 VACrms	LESS 2 mSec	LESS 2 mSec	LESS 15 PF	100 g
KG1010D	200 V/ μ SEC	2.0Vrms	10^9 ohm	4000 VACrms	4000 VACrms	LESS 2 mSec	LESS 2 mSec	LESS 15 PF	100 g
KG1025D	200 V/ μ SEC	2.0Vrms	10^9 ohm	4000 VACrms	4000 VACrms	LESS 2 mSec	LESS 2 mSec	LESS 15 PF	100g
KG1040D	200 V/ μ SEC	2.0Vrms	10^9 ohm	4000 VACrms	4000 VACrms	LESS 2 mSec	LESS 2 mSec	LESS 15 PF	100g
KG1050D	200 V/ μ SEC	2.0Vrms	10^9 ohm	4000 VACrms	4000 VACrms	LESS 2 mSec	LESS 2 mSec	LESS 15 PF	100 g
KG1075D	200 V/ μ SEC	2.0Vrms	10^9 ohm	4000 VACrms	4000 VACrms	LESS 2 mSec	LESS 2 mSec	LESS 15 PF	100g

OUTLINE DIMENSIONS (unit:mm)

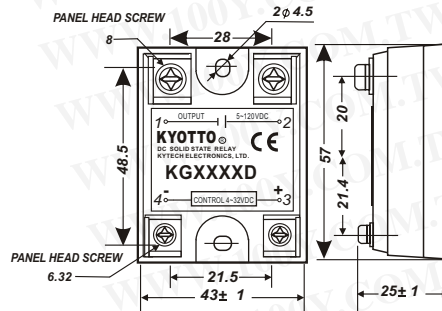

勝特力材料 886-3-5753170
 勝特力电子(上海) 86-21-34970699
 勝特力电子(深圳) 86-755-83298787
[Http://www.100y.com.tw](http://www.100y.com.tw)

EQUIVALENT CIRCUIT

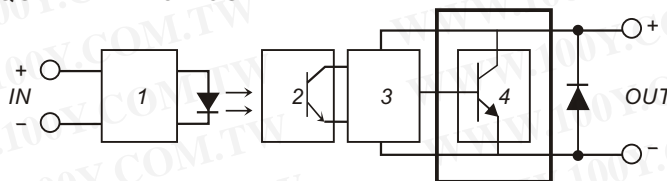

- 1.INPUT CIRCUIT
- 2.PHOTO DETECTOR
- 3.AMPLIFIER
- 4.PROTECTED CIRCUIT

CHARACTERISTIC CURVES

