

3 1/2 DIGITAL METER OF PROGRAMMABLE

勝特力材料 886-3-5753170
 勝特力电子(上海) 86-21-34970699
 勝特力电子(深圳) 86-755-83298787
 Http://www.100y.com.tw



FEATURES

- Measuring DCA, DCV, ACA, ACV, Potentiometer, Pt-100, Thermocouple, Transmitter, Load Cell etc...
- Wide switchable readout range
- Accuracy 0.1% F.S. ±1 digit (DC, AC (TRMS), Potentiometer, Load Cell, Pt-100, Transmitter)
- High stability and Dimension small

1. MODEL: PFP - 1 - [] - [] - [] - [] → NON-PROGRAMMABLE

NO	Input Type	NO	DCV (ACV)	NO	DCA (ACA)	NO	Potentiometer	NO	Pt-100	NO	Thermocouple	NO	Load Cell	NO	Transmitter	NO	Aux. Power
A	DC	11	0-50.0 mV	21	0-19.99 μA	31	0-10%	41	-50~50°C	51	0~600°C(J)	61	2.0mV/V	71	DC 4-20mA	1	AC 110/220V
B	AC(RMS)	12	0-199.9 mV	22	0-199.9 μA	32	0-50%	42	-100~100°C	52	0~1200°C(K)	62	3.0mV/V	72	DC 1-5V	2	DC 24V
C	* AC(TRMS)	13	0-1999 mV	23	0-1.999 mA	33	0-100%	43	-199.9~199.9°C	53	0~1600°C(R)	63	* 2.0mV/V	73	DC 4-20mA	3	DC 48V
D	Potentiometer	14	0-5 V	24	0-19.99 mA	34	5-95%	44	0~850°C	59	SPECIFIED	64	* 3.0mV/V	74	DC 1-5V	4	DC 110V
E	Transmitter	15	0-10 V	25	0-199.9 mA	35	10-90%	45	-200~850°C	• Accuracy 0.2% ±1°C • Internal CJC trace ability ≤ ±0.5°C ≤ 10 min. warm up	69	SPECIFIED	79	SPECIFIED	5	DC 220V	
F	* Pt-100(RTD)	16	0-35 V	26	0-1.999 A	39	SPECIFIED	49	SPECIFIED		• Exciting voltage DC 12V (≤50mA)	• 71-72 non-exciting DC 20V • 73-74 exciting DC 20V (≤25mA)	6	AC 90~260V			
G	* Thermocouple	17	0-600 V	27	0-5.00 A	• Three wire connection • Exciting voltage DC 5V (≤5mA)	• Three wire connection	• Three wire connection	• Three wire connection	• Accuracy 0.2% ±1°C • Internal CJC trace ability ≤ ±0.5°C ≤ 10 min. warm up	• Exciting voltage DC 12V (≤50mA)	• 71-72 non-exciting DC 20V • 73-74 exciting DC 20V (≤25mA)	9	SPECIFIED	• ±20% of rate, less 3.5VA for AC input • ±20% of rate, less 3WATT for DC input		
H	Load Cell	18	0-1000 V	28	0-10.00 A								• ±20% of rate, less 3.5VA for AC input • ±20% of rate, less 3WATT for DC input				
O	SPECIFIED	19	SPECIFIED	29	SPECIFIED												

note: * non-programmable

2. Specification

- Aux. power supply : AC110 & 220V ±20% (50 or 60Hz) (Optional DC 24V or 48V or 110V or 220V switching AC100~240V ±10%)
- Measuring accuracy : 0.1% F.S. ±1 digit (DC, AC(TRMS), Potentiometer, Load Cell, Pt-100, Transmitter) 0.15% F.S. ±1 digit (AC(RMS))
- Sampling time : 3 cycles/sec. or more
- Input impedance : 1MΩ or more (DC, AC)
- Over input indication : "1" or "-1"
- Display : Red high efficiency LEDs high 14.22mm (.56"), .8" OPTIONAL
- Polarity display : When input is negative, "-" displayed
- Temp. coefficient : 100ppm/°C (0-50°C)
- Dielectric strength : 1.5KVac / 1min. (input/power)
- Operating condition : 0~50°C (20 to 90% RH non-condensed)
- Storage condition : 0~70°C (20 to 90% RH non-condensed)
- Weight (about) : 320g

3. Outside dimension and connection diagram

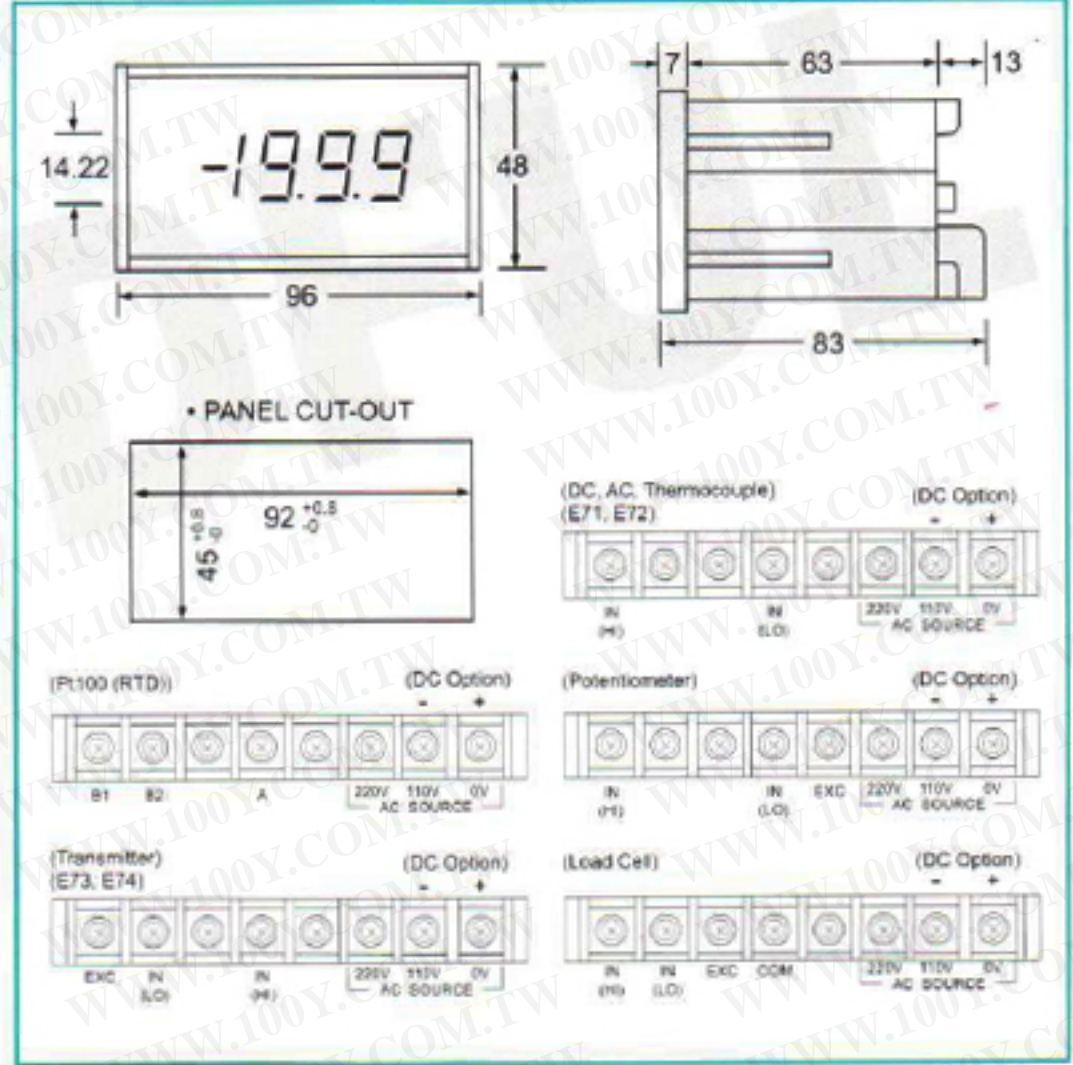

4. Program of span (GAIN) and decimal point set

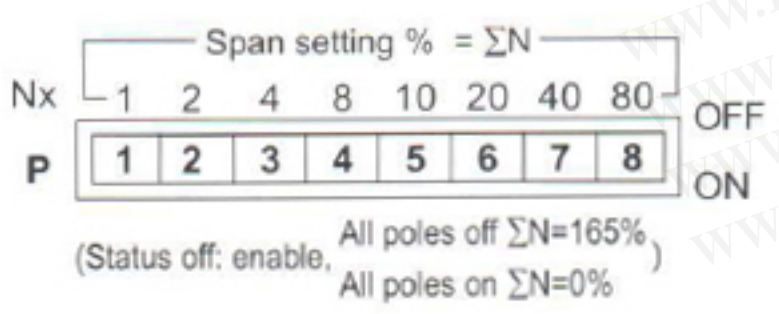

5. Programming formula

- DH/DL: display high range/display low range
- ▲ $\Sigma N = [(DH-DL)/20]\%$
 - ▲ Example: Input AC 0-5A, display 0-100.0A
 - (1) $\Sigma N = [(1000-0)/20]\% = 50\%$
 - (2) Setting span(ΣN) → P5-P7=off & the rest on
 - (3) Adjusting
 - 3-1 input=0A adjust "ZERO" to "000" readout
 - 3-2 input=5A adjust "SPAN" to "1000" readout
 - (4) setting decimal point "3" on
 - (5) END