

eliwell



cod. 9IS43013
rel. 12/04

IC 917 (LX)

electronic controller with dual output,
PID regulator and autotuning

勝特力材料 886-3-5753170
勝特力电子(上海) 86-21-54151736
勝特力电子(深圳) 86-755-83298787
Http://www.100y.com.tw

USER INTERFACE

The user has a display and four keys for controlling status and programming of the instrument.

KEYS AND MENUS

UP key		Scrolls through the menu items Increases the values Can be set by parameter (par. H31)
DOWN key		Scrolls through the menu items Decreases the values Can be set by parameter (par. H32)
fnc key		ESC function (exit) Can be set by parameter (par. H33)
set key		Accesses the setpoint Accesses the menus Activates the functions* Confirms the commands Displays the alarms (if active)

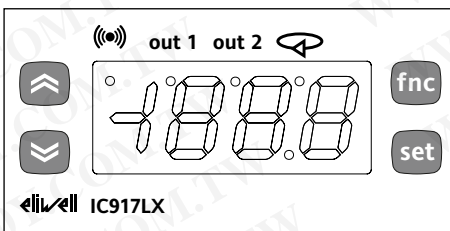

At start-up the instrument performs a Lamp Test; for few seconds the display and the leds blink, in order to verify their integrity and correct operation. The instrument has two main menus: the "Machine Status" and "Programming" menu.

ACCESSING AND USING MENUS

Resources are arranged in a menu, which can be accessed by pressing and quickly

LED

Position	Related Function	Status
OUT1	Relay 1 (OUT1)	ON for relay on; blinking for delay, locked protection or activation
OUT2	Relay 2 (OUT2)	ON for relay on; blinking for delay, locked protection or activation
	Alarm	ON when the alarm is enabled; blinking when the alarm is silenced
	Soft Start/Autotuning (and Setpoint setting)	ON when setting Setpoint; blinking when Soft Start and/or autotuning is enabled;
aux	aux	ON when auxiliary output is functioning
	decimal point	ON when instrument is on standby*

*optional, as when the machine is OFF the display will show the label OFF

releasing the "set" key ("Machine Status" menu) or by holding down the "set" key for more than 5 seconds ("Programming" menu).

To access the contents of each folder, indicated by the relevant label, just press the "set" key once.

You can now scroll through the contents of each folder, modify it or use its functions. If you do not use the keyboard for over 15 seconds (time-out) or if you press the "fnc" key once, the last value shown on the display is confirmed and you return to the previous screen mask.

MACHINE STATUS MENU

(See Machine Status Menu Diagram)

To access the "Machine Status" menu press and quickly release the "set" key. The label "SP1" appears.

By using the "UP" and "DOWN" keys you can scroll through the other folders in the menu:

- AL: alarm folder (if alarms present, except for faulty probe(s)/probe(s) error(s);
- SP1: Setpoint 1 setting folder.
- SP2: Setpoint 2 setting folder.

Setpoint 1 (Setpoint 2) Setting

Access the "Machine Status" menu by pressing and quickly releasing the "set" key. The label of the "SP1" folder appears. (To set Setpoint 2 use the "UP" and "DOWN" keys until it is shown "SP2".

To display the Setpoint 1 (2) value press the "set" key again.

The value appears on the display.

To change the Setpoint 1 (2) value, use the "UP" and "DOWN" keys within 15 seconds.

If the parameter is LOC = y the Setpoint cannot be changed.

Alarm on

If an alarm condition exists, when accessing the "Machine Status" menu the "AL" folder label appears (see the "Diagnostics" section).

PROGRAMMING MENU

(See Programming Menu Diagram)

1) Level 1 Parameters

To access the "Programming" menu, press the "set" key for more than 5 seconds. If specified, the level 1 access PASSWORD will be requested (see parameter "PA1") and (if the password is correct) the label of the first folder will follow. If the password is wrong, the display will show the PA1 label again.

To scroll other folders, use the "UP" and "DOWN" keys. **The folders contain only the level 1 parameters.**

NOTE: At this point level 2 parameters are NOT visible, even if they aren't protected by password.

2) Level 2 Parameters

In the Programming Menu go into the "CnF" folder, scroll all the parameter until you reach the PA2 label. By pressing and releasing the "set" button you will enter to level 2 parameters and the label of the first folder in the programming menu will follow.

The level 2 parameters may be protected by a second password (see "PA2" parameter inside "dis" folder, not to be confused with PA2 label inside "CnF" folder.

If specified, level 2 parameters are hidden to user; accessing the "CnF" folder the level 2 access PASSWORD will be requested and (if the correct password is entered) the label of the first folder in the programming menu will follow.

NOTE: At this point you will see only level 2 parameters.

Level 1 parameters will NOT be visible; to reach them you shall exit the Programming Menu and re-entry the Programming Menu section (see step 1).

To enter the folder, press "set". The label of the first visible parameter appears. To scroll through the other parameters, use the "UP" and "DOWN" keys; to change the parameter, press and release "set", then set the desired value using the "UP" and "DOWN" keys, and confirm with the "set" key. Move to the next parameter.

PLEASE NOTE: It is suggested to switch-off and switch-on again the instrument everytime it is changed the configuration of the parameters: this prevents malfunctioning on regulation and delay time occurring.

*FOLDER FUNCTIONS FnC

Inside Fnc folder (last folder visible from Programming Menu, level 1) there are available the following functions: (see table next page; enable them with the "set" button).

When you turn Off the instrument all labels return to default status.

Function	Label function ENABLED	Label function DISABLED
Soft Start	Son	SoF**
Reduced Set	OSP	SP**
Activation stopped	bon**	boF
Periodical Cycle	con	coF
Aux	Aon	AoF
Stand-by	on**	oF
Maintenance required	Atn	AtF**

NOTE: In this case the label UnP will be shown (blinking) in
**default

PASSWORD

The passwords "PA1" and "PA2" allow access respectively to level 1 and level 2 parameters. In the standard configuration passwords are not present. To enable them (value ≠ 0) and assign them the desired value, access the "Programming" menu, within the folder with the "diS" label. If passwords are enabled, they will be requested:

- PA1 at the entrance of the "Programming" menu (see the "Programming Menu" section);
- PA2 within the folder with the "Cnf" label containing level 1 parameters.

COPY CARD

The Copy Card is an accessory connected to the TTL serial port which allows programming quickly the instrument parameters (upload and download parameter's map). The operation is performed as follows:

Fr-Format

This command allows Copy Card formatting, an operation **necessary** in case of first use or to copy maps with different models. Warning: if the Copy Card has been programmed, using the "Fr" the data entered are erased. This operation cannot be cancelled.

UL-Upload

This operation loads the programming parameters from the instrument.

dL-Download

This operation downloads to the instrument the programming parameters.

PLEASE NOTE:

- **UPLOAD: instrument --> Copy Card**
- **DOWNLOAD: Copy Card --> instrument.**

The operations are performed accessing the folder identified by the "FPi" label and selecting, according to the case, "UL", "dL" or "Fr" commands; the operation is confirmed by pressing the "set" key. If the operation is successful an "y" is displayed, on the contrary, if it fails a "n" will be displayed.

Download "from reset" (instrument OFF)

Connect the copy card with the instrument OFF (not under voltage).

When the instrument is switched on the programming parameters will be downloaded into the instrument; after the lamp-test the display will show for about 5 seconds:

- label dLY if copy operation successful
- label DLn if not

PLEASE NOTE:

- after the download operation the instrument will immediately work with the new parameters map setting

KEYBOARD LOCKING

The instrument includes a facility for disabling the keyboard, by programming the "LOC" parameter (see folder with "diS" label). If the keyboard is locked, you can still access the programming menu by pressing the "set" key.

The Setpoint can also be viewed.

TELEVIS SYSTEM

The TelevisSystem can be connected through TTL serial port (the TTL- RS 485 BUS ADAPTER 130 interface module must be used).

To configure the instrument for this purpose you need to access to the folder identified by the "Add" label and to use the "dEA" and "FAA" parameters.

ADVANCED FUNCTIONS

PID CONTROL

The PID control algorithm acts on the difference between the set point and the measured temperature. This difference affects the output implementation where the output is modulated over a period established by the parameter PEr. The controller calculates a process value (between the values of parameter SLo and SHi expressed as a percentage - max range 0...100%). This percentage is transformed into the time period in which the OUT1 relay contact is kept closed. This time is the calculated percentage of PEr. Example:

- Calculated process value: 40%
- Time: 10 sec

On time = 4 sec (for the remaining 6 seconds the relay stays open).

The PID controller calculates the process value by summing 3 components:

- proportional: value based on the instant error at the time of calculation. This component's contribution is established by the value of parameter HP (the higher the HP parameter, the greater the contribution of this proportional component)
- integral: value based on the integral of error. This component is based on the total number of errors observed in a period established by parameter "ti" before the moment of calculation. This compo-

nent's contribution is smaller the higher the "ti" parameter. The integral component corrects constant offsets from the set point.

- derivative: value based on the rate of change of error. This component is based on the rate of change of error in a period established by the "td" parameter before the moment of calculation. The contribution of this component is greater the higher the "td" value. The derivative component limits strong oscillations.

N.B.:PID control acts exclusively on the OUT1 output (with H21=2 see parameter table); it only works in "heating" mode.

The PID controller must be sized according to the thermodynamic characteristics of the controlled system. This means that parameters "HP", "ti" and "td" must be sized correctly. The instrument provides an auto-tuning function. This function allows the instrument to calculate the above parameters and automatically size the PID controller. However, this sizing must be checked by performing special tests. (see **auto-tuning**)

If auto-tuning lasts for longer than the period established by parameter AtO, a tOA label will appear on the display that indicates that auto-tuning has failed.

If this occurs, we recommend that system conditions are checked. They must be stable during the auto-tuning cycle and the AtO value must be increased, if necessary, before trying again.

To optimize the behaviour of the controller, we recommend adopting the following measures:

- the integral component increases when a high level of error is present (start-up with temperature a long way from the set point, for example). This increase may lead to an over-oscillation that could be unacceptable to the application. To avoid this, back-calculation is used. This function limits the integral component when the process value is greater than the SHi parameter (i.e., it is "saturated"). The back-calculation function is more effective the lower the value of the tt parameter. The tt parameter is not calculated by the auto-tuning function and the user must perform a series of tests in order to define it. Attention must also be paid to the SHi value. This establishes the maximum process value beyond which back-calculation intervenes on the integral component.
- The derivative component may be subject to "high frequency" oscillations. To prevent these oscillations, parameter "n" must be sized so that a low-pass filter can be sized. This filter will be more effective the lower the value of this parameter.

AUTO-TUNING

Closed loop auto-tuning:

- access programming and locate the Pid folder;
- once inside the folder, SEt will appear
- press 'set' and display the parameter group P1, P2, or P3 that you want to work with. Confirm with 'set'
- set the following parameters in the Pid folder:
 run=FIH
 dLt=10 auto-tuning will close if the system behaviour stabilizes with 10% tolerance
 FUn=Pid the auto-tuning calculates the P, i and d control components
 Ato=2 max time (in hours) for completing auto-tuning procedure. If by this time the procedure has not been completed, the controller displays the error Ato;
 PEr=20 represents, in seconds, the time elapsing between 2 consecutive start-ups of the relay
 dut=10% is the value, expressed as a percentage, calculated according to 'PEr', that determines the relay activation time: activation time=10% of 'PEr'
- then select the 'tun' parameter and set the CLO value. When confirmed with "set", the auto-tuning LED will flash to indicate the start of the process: the relay will be activated for temperature values that are lower than the preset set-point (SP1) and deactivated for higher values (it considers the values at a tenth of a degree, i.e. if SP1=70.0°C, the relay is active for temperatures that are lower than 69.9°C and inactive for temperatures above 70.0°C); in this phase, very large temperature oscillations can be reached compared with SP1 (both higher and lower);
- the auto-tuning LED goes out to indicate that auto-tuning has terminated. At this point, access the Pid folder again, select the run parameter and set it to "Aut" to activate the parameters that have previously been calculated.

Open loop auto-tuning

- access programming and locate the Pid folder;
- once inside the folder, SEt will appear;
- press the Set button and display the parameter group P1, P2, or P3 that you want to work with. Confirm by pressing the Set button again;
- set the following parameters in the Pid folder:
 dLt=10 auto-tuning will close if the system behaviour stabilizes with 10% tolerance
 FUn=Pid the auto-tuning calculates the P, i and d control components;
 Ato=2 max time (in hours) for completing the auto-tuning procedure. If by this time the procedure has not been completed the controller displays the error Ato;
 PEr=20 represents, in seconds, the time elapsing between 2 consecutive start-ups of the relay;
 dut=10% is the value, expressed as a percentage, calculated according to PEr that determines the relay activation time: activation time =10% of 'PEr';
- Then set the run parameter to value FIH. From now on, the relay output will operate with a fixed operating cycle established by "PEr" and "dut". Wait for the temperature oscillations to stabilize between a minimum and maximum value;
- Access the Pid folder again
 APL=20% represents the increase in dut that leads to a variation in process conditions. Auto-tuning is calculated according to this variation: dut is increased by 20%
- then select the tun parameter and set the OPE value. When confirmed with Set, the auto-tuning LED will flash to indicate the start of the process;
- the auto-tuning LED goes out to indicate that auto-tuning has ended. At this point, access the Pid folder again, select the run parameter and set it to Aut to activate the parameters that have previously been calculated;
- finally, select the Act parameter and select the "Sau" option. Confirm using the Set button. In this way the calculated parameters are saved in the program selected at the start of the procedure (P1, P2 or P3);
- check the tuning in this condition and repeat the procedure if results are not satisfactory by selecting the same group of parameters or the next one (P1, P2 or P3);

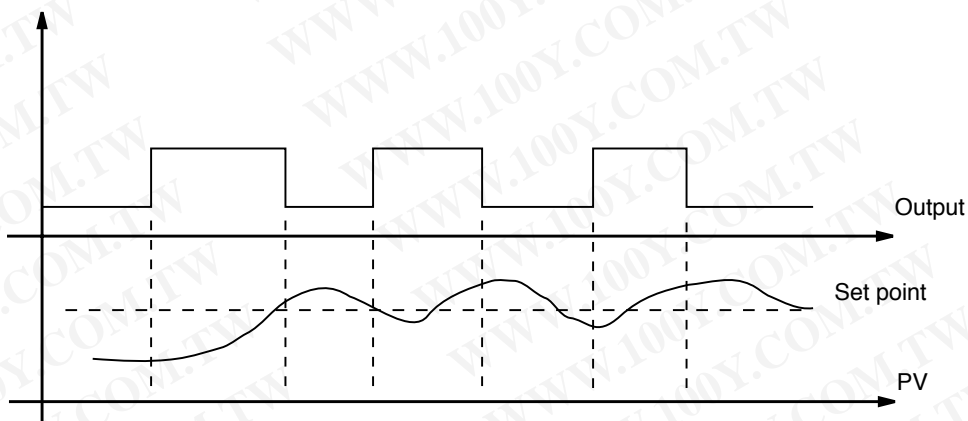

Closed loop auto-tuning:



Open loop auto-tuning:

STAND BY/ON-OFF

Note: The STAND BY/ON-OFF function can be selected rapidly by pressing the fnc key for at least 2 seconds.

Once the STAND-BY/ON-OFF function has been enabled, the display turns off, all controls are locked, including any alarms, and all cycle times are reset.

The status is stored, so that when the power is restored after a black-out the instrument can resume operation in the status in which it was before the power failure. After starting, the temperature alarm is stopped for an amount of time set with parameter PAO.

SOFT START

Note: the SOFT START function can be enabled by key, Digital Input or by function.

The Soft Start regulator permits to set the temperature gradient to reach a defined setpoint in a defined lapse of time.

Through this function, actually, you can obtain a progressive increase of the Setpoint (on which you regulate) from the Ta value (environment Temperature at instruments' start-up) to the real value set on display; this permits to delay the increase of the temperature reducing "overshooting" problems.

Soft Start parameters are visible in the "SOFT START" folder (defined by the "Sft" label)

PERIODICAL CYCLE

Note: Periodical Cycle function can be enabled by key, Digital Input or by function.

This function can be associated to both relay outputs (set parameters H21, H22 to 4) and permits to activate a "Duty Cycle" regulation with the timings defined by Con and CoF (see **Periodical Cycle Diagram**)

AUX (Auxiliary Regulator)

The Digital Input can be set as "auxiliary" (parameter H11=5): in this case define the regulator output 1(2) as aux (auxiliary) through H21(22) parameters.

This function permits to activate the relay if it was not excited or to leave it excited on the other side. The status will be stored, to ensure a correct functioning, in case of black-out, except when you set parameter H11=5 (aux); in this case the relay status is the same as the Digital Input status.

Through parameter H13 you can define priorities/polarity between activation through key, relay and Digital Input.

NOTE: The meaning of the Digital Input (D.I.) should remains the same: e.g. enabling relay from D.I. and disabling it from key, if you reset the D.I. the relay doesn't change its status because it is disabled from key.

DIAGNOSTICS

The alarm condition is always signalled by the buzzer (if present) and by the led of

the alarm icon (🔊)

Probe faults table

DISPLAY	FAULT
E1	Faulty probe 1 (regulator)

The alarm signal produced by:

- a regulator probe that measures a value outside probe's range
- a faulty regulator probe /short-circuit-

On1 (On2)	OF1 (OF2)	Regulator Output
0	0	OFF
0	>0	OFF
>0	0	ON
>0	>0	D.C.

see **Duty Cycle Diagram**

ed/open probe

is shown as E1 on the instrument display When the sensor detects an error condition:

- the code E1 is displayed
- the regulator is activated as indicated by the "On1 (On2)" and "OF1 (OF2)" parameters if programmed for the duty cycle or:

PLEASE NOTE (ONLY FOR Pt100 MODELS): In case of wrong connection of the 3rd wire (Pt100 sensor) in "AL" folder it will appear the label "Pt3".

For few seconds the display will shows a uncorrect temperature.

MAXIMUM AND MINIMUM TEMPERATURE ALARM

In case of alarm condition, if alarm exclusion times are not in progress (see, alarm exclusion parameters), the fixed alarm icon is turned on and the relay configured as an alarm is activated. This kind of alarm does not affect the regulation in progress. Alarms are considered as absolute (Abs, default) values or as values related to the

Alarms Table

DISPLAY	ALARM
*AH1	High temperature alarm (referred to regulator 1)
*AL1	Low temperature alarm (referred to regulator 1)
*AH2	High temperature alarm (referred to regulator 2)
*AL2	Low temperature alarm (referred to regulator 2)
EA	External alarm
Opd	Open door alarm (LX models)

To silence the alarm, press any keys.

In this case the LED will blink

*Alarms are considered as absolute values or as values related to the Setpoint based on the Att parameter. See **Max-Min Alarms Diagram**

Setpoint (rEL, the distance from the Setpoint itself) and based on the Att parameter. In this case (Att=rEL), the HA1(2) parameter must be set to positive values and the LA1(2) parameter to negative values.

This alarm condition can be viewed in the folder "AL" with the labels "AH1(2)-AL1(2)".

EXTERNAL ALARM

The device includes the possibility to control an external alarm, from a digital input. If the digital input is active, the alarm control is activated, if programmed, and stays until the next time the digital input is deactivated. The alarm is signaled by turning on the fixed alarm icon, by activating the relay configured as alarm, and by deactivating the regulators (if specified by the "H11=9" parameter).

This alarm condition can be viewed in the "AL" folder with the label "EA". The relay can be silenced; even if alarm icon starts blinking, controls stay locked until the next time the digital input is deactivated.

INSTALLATION

The instrument is designed for panel mounting. Make a hole of 29x71 mm, insert the instrument and fix it using the brackets provided. Do not mount the instrument in humid and/or dirty places; it is suitable for use in ordinary polluted places. Ventilate the place in proximity to the instrument colling slits.

ELECTRICAL WIRING

Attention! Never work on electrical connections when the machine is switched on.

The instrument is equipped with screw terminal boards for connection of electrical cables with a diameter of 2.5 mm² (one conductor only per terminal for power connections).

For the capacity of the terminals, see the label on the instrument.

The relay contacts are voltage free. Do not exceed the maximum current allowed; in case of higher loads, use an appropriate contactor. Make sure the power supply voltage complies with the one required by the instrument.

In 12V versions the power supply must be provided by a security transformer with the protection of a delayed 250 mA fuse. Probes have no connection polarity and can be extended using a regular bipolar cable (note that the extension of the probes affects the EMC electromagnetic compatibility of the instrument: pay extreme attention to wiring). Probe cables, power supply cables and the TTL serial cables should be distant from power cables.

CONDITIONS OF USE

PERMITTED USE

For safety reasons the instrument must be installed and used according to the instruction provided and in particular, under normal conditions, parts bearing dangerous voltage levels must not be accessible.

The device must be adequately protected from water and dust as per the application and must also only be accessible via the use of tools (with the exception of the frontlet).

The device is ideally suited for use on household appliances and/or similar refrigeration equipment and has been tested with regard to the aspects concerning European reference standards on safety. It is classified as follows:

- according to its manufacture: as an automatic electronic control device to be incorporated by independent mounting;
- according to its automatic operating features: as a 1 B-type operated control type;
- as a Class A device in relation to the category and structure of the software

UNPERMITTED USE

Any other use other than that permitted is de facto prohibited. It should be noted that the relay contacts provided are of a practical type and therefore subject to fault. Any protection devices required by product standards or dictated by common sense due to obvious safety reasons should be applied externally.

LIABILITY AND RESIDUAL RISKS

Eliwell & Controlli s.r.l. shall not be liable for any damages deriving from:

- installation/use other than that prescribed and, in particular, that which does not comply with safety standards anticipated by regulations and/or those given herein;
- use on boards which do not guarantee adequate protection against electric shock, water or dust under the conditions of assembly applied;
- use on boards which allow access to dangerous parts without the use of tools;
- tampering with and/or alteration of the products;
- installation/use on boards that do not comply with the standards and regulations in force.

DISCLAIMER

This manual and its contents remain the sole property of Eliwell & Controlli s.r.l., and shall not be reproduced or distributed without authorization. Although great care has been exercised in the preparation of this document, Eliwell & Controlli s.r.l., its employees or its vendors, cannot accept any liability whatsoever connected with its use. Eliwell & Controlli s.r.l. reserves the right to make any changes or improvements without prior notice.

IC 917 (LX)

TECHNICAL DATA

Frontal panel protection: IP65.

Casing: plastic body in resin type PC+ABS UL94 V-0, inspection window in polycarbonate, buttons in thermoplastic resin.

Dimensions: frontal panel 74x32 mm, depth 59 mm (without wirings).

Installation: on panel, with drilling template 71x29 mm (+0.2/-0.1 mm).

Use temperature: -5...55 °C.

Storage temperature: -30...85 °C.

Use environment humidity: 10...90 % RH (not condensing).

Storage environment humidity: 10...90% RH (not condensing).

Serial: TTL for connection to Copy Card and (LX MODELS) TelevisSystem.

Analogue input: one PTC or NTC input (programmable by parameter).

Digital input

(ONLY LX MODELS) 1 voltage-free digital input that can be set by parameter.

Digital outputs: 1 SPDT output on 8(3)A 1/2 hp, 1 SPST output on 8(3)A 1/2 hp configurables. (for relay capabilities see label on the instrument)

Buzzer output: only on models with Buzzer.

NTC-PTC MODELS

Display range:

- NTC probe: -50...110°C (-58...230°F);
- PTC probe: -55...140°C (-58...302°F)

3 and a half digit display + sign.

Analogue input: one PTC or NTC input (selectable with parameter).

Measurement range: -55 to 140 °C.

Accuracy: better than 0.5% of bottom of the scale + 1 digit.

Resolution: 0,1°C (0,1°F to +199,9°F; 1°F beyond).

Consumption:

- 230V model: 3 VA max.;
- 12/24V model: 1,5 VA max.

Power supply: 12/24 V \pm 10% or 230V \pm 10% 50/60 Hz.

Pt100-TcJ/TcK MODELS

Display range:

- model Pt100: -150...650°C, with decimal point based on ndt parameter
- model TcJ -40...750°C*
- model TcK -40...1350°C*

*without decimal point

3 and a half digit display + sign.

NOTE: display is therefore to the nearest tenth of a degree °C in model Pt100 and to the nearest degree °C in models TcJ/TcK

Analogue input: one Pt100 or TcJ or TcK input, depending on model;

Measurement range: from -150 to 1350.

Accuracy:

- model Pt100: 0,5% throughout range + 1 digit; 0,2% from -150 to 300°C.

- model TcJ 0,4% throughout range + 1 digit;

- model TcK 0,5% throughout range + 1 digit; 0,3% from -40 to 800°C.

Resolution:

- model Pt100: 0,1°C (0,1°F) up to 199,9 °C, 1°C (1°F) beyond

- model TcJ/TcK 1°C (1°F).

Resolution:

- model Pt100: 0,1°C (0,1°F) up to 199,9 °C, 1°C (1°F) beyond

- model TcJ/TcK 1°C (1°F).

Consumption:

- model 230V: 3 VA max.;
- model 12/24V: 1,5 VA max.

Power supply: 12/24 V \pm 10% or 230V \pm 10% 50/60 Hz.

Warning: check the power supply specified on the instrument label; for relay and power supply capacities, contact the Sales Office).

PLEASE NOTE: The technical data included in this document, related to measurement (range, accuracy, resolution, etc.) refer to the instrument itself, and not to its equipment such as, for example, sensors. This means, for example, that sensor(s) error(s) shall be added to the instrument's one.

Periodical Cycle Diagram

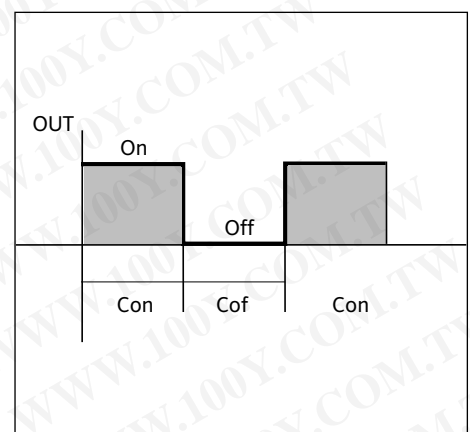

****NOTE: At level 1 the folders will show only level 1 parameters. At level 2 the folders will show only level 2 parameters.**

Tab. 1 Parameter Table

PAR.	DESCRIPTION	RANGE	DEFAULT*	VALUE**	LIEVEL***	U.M.
HC1	REGULATOR 1 (folder with "rE1" label) Heat/Cool Mode. If set to H the generic regulator actuates for hot operation. If set to C the generic regulator actuates for cold operation Intervention 1 band see ON-OFF regulation diagram	(PTC-NTC / Pt100-TC) (PTC-NTC / Pt100-TC) H/C	H/C*		1	flag
OS1	Offset Setpoint 1	-30.0...30.0	0		2	°C/°F
db1	Operating Range 2 see ON-OFF regulation diagram	0...30.0	1*		1	°C/°F
dF1	differential. Relay 1 tripping differential. The regulator stops on reaching the Setpoint value (as indicated by the adjustment probe), and restarts at temperature value equal to the Setpoint 1 plus (o minus depending on HC1) the value of the differential. see ON-OFF regulation diagram	0.0...30.0	0 (models n.z.)* 1*		1	°C/°F
HS1	Higher SEt. Maximum possible setpoint 1 value.	LS1..HdL	140* /*		1	°C/°F
LS1	Lower SEt. Minimum possible setpoint 1 value.	LdL..HS1	-50* /*		1	°C/°F
HA1	Maximum Alarm OUT1 See Max/Min. Alarm Diagram	LA1...350.0 /LA1...1999	140* /*		1	°C/°F
LA1	Maximum Alarm OUT2 See Max/Min. Alarm Diagram	-99.9...HA1/-328...HA1	-50* /*		1	°C/°F
REGULATOR 1 PROTECTIVE DEVICE (folder with "rE1" label)						
dn1	Delay time in activating the regulator relay after switch-on of instrument.	0...250	1		1	°C/°F
do1	Delay after switch off. The indicated time must elapse between switch-off of the regulator relay and the successive switch-on.	0...250	0		1	sec
di1	Delay between switch-ons. The indicated time must elapse between two successive switch-ons of the regulator.	0...250	0		1	min
dE1	Delay before switch-off. The indicated time must elapse between switch-off request and the switch-off of the regulator. PLEASE NOTE: for parameters dn1, do1, di1, dE1 0= not active	0...250	0		1	min
On1	On time (regulator 1). Regulator activation time in the event of faulty probe. If set to "1" with OF1 at "0" the regulator is always on, while at OF1 >0 it functions always in duty cycle mode. see Duty Cycle diagram	0...250	0		1	sec
OF1	OFF time (regulator 1). Regulator in disabled state time in the event of a faulty probe. If set to "1" with On1 at "0" the regulator is always off, while at On1 >0 it functions always in duty cycle mode. see DC diagr.	0...250	1		1	min
REGULATOR 2 (folder with "rE2" label)						
HC2	Heat/Cool Mode. If set to H the generic regulator actuates for hot operation. If set to C the generic regulator actuates for cold operation Intervention 2 band see ON-OFF regulation diagram	H/C	H/C*		1	min
OS2	Offset Setpoint 2	-30.0...30.0	0		2	flag
db2	Operating Range 2 see ON-OFF regulation diagram	0...30.0	1*/*		1	°C/°F
dF2	differential. Relay 1 tripping differential. The regulator stops on reaching the Setpoint value (as indicated by the adjustment probe), and restarts at temperature value equal to the Setpoint 1 plus (o minus depending on HC1) the value of the differential. see ON-OFF regulation diagram	0.0...30.0	0 (models n.z.)* 1*/*		1	°C/°F
HS2	Higher SEt. Maximum possible setpoint 2 value.	LS1..HdL	140*/*		1	°C/°F
LS2	Lower SEt. Minimum possible setpoint 2 value.	LdL..HS1	-50*/*		1	°C/°F
HA2	Maximum Alarm OUT1 See Max/Min. Alarm Diagram	LA2...350.0	140*/*		1	°C/°F
LA2	Maximum Alarm OUT2 See Max/Min. Alarm Diagram	-99.9...HA2	-50*/*		1	°C/°F
REGULATOR 2 PROTECTIVE DEVICE (folder with "rE2" label)						
dn2	Delay time in activating the regulator relay after switch-on of instrument.	0...250	1		1	sec
do2	Delay after switch off. The indicated time must elapse between switch-off of the regulator relay and the successive switch-on.	0...250	0		1	min
di2	Delay between switch-ons. The indicated time must elapse between two successive switch-ons of the regulator.	0...250	0		1	min
dE2	Delay before switch-off. The indicated time must elapse between switch-off request and the switch-off of the regulator. PLEASE NOTE: for parameters dn2, do2, di2, dE2 0= not active	0...250	0		1	sec
On2	On time (regulator 2). Regulator activation time in the event of faulty probe. If set to "1" with OF1 at "0" the compressor is always on, while at OF2 >0 it functions always in duty cycle mode. see Duty Cycle diagram	0...250	0		1	min
OF2	OFF time (regulator 2). Regulator in disabled state time in the event of a faulty probe. If set to "1" with On2 at "0" the regulator is always off, while at On2 >0 it functions always in duty cycle mode. see DC diagr.	0...250	1		1	min
PID (folder with label "PID")						
SEt	Set of parameters to use	P1, P2, P3	P1		1	num
Act	Action to be performed on the selected set of parameters. Abo = go back to previous menu without making any changes; LoA = load parameters using auto tuning; SAu = save parameters using auto tuning.	Abo, LoA, SAu	Abo		1	num
run	automatic mode (pid) or manual mode (fixed duty cycle)	FiH/Aut	FiH		1	flag
dut	duty cycle to be used in manual mode (run=FiH)	00.0%... 100.0%	0		1	%
HP	proportional gain	1...1000	40		1	num
ti	integral time	1...1000	240		1	num
tt	integral time for back calculation	1...100	100		1	num
td	derivative time	1...1000	60		1	num
n	derivative component limit	1...30	5		1	num
PEr	output activation period	4...256	10		1	sec
SHi	maximum output saturation (percentage)	0...1000	100		1	%
SLO	minimum output saturation (percentage)	0...1000	0		1	%
APL	Amplitude of the step to be applied to the system	0...100	0(°)		1	%
dLt	Percentage variation permitted on the PV to determine achievement of a new state of balance	0...100	10(°)		1	%
ATo	Time-out in auto tuning	1...10	1(°)		1	ore
Fun	Type of temperature controller desired by auto tuning	P, PI, PID	P		1	num
tun	Activation of auto tuning	IdL, cLo, StE	IdL		1	num

PAR.	DESCRIPTION	RANGE	DEFAULT*	VALUE**	LEVEL***	U.M.
dSi	SOFT START (folder with label "SfT") dynamic Step increment (Step Value). Value (°C/°F) of every incremental step (dynamic) of the regulation (set)point. 0=disable SOFT START function. dynamic Step time (Step Duration). Delay time between two steps	0...25.0	0		2	°C/°F
dSt	(dynamic) of the regulation (set)point U.M (hours, minuts, seconds)	0...250	0		2	H/m/sec
Unt	Outputs enabled. Define on which output the function should be enabled: 0 = function disabled; 1 = OUT 1; 2 = OUT 2; 3 = OUT 1 & 2;	0/1/2	0		2	H/m/sec
SEn	Function Threshold re-entry . Define the threshold, over which there is the automatic re-entry of the SOFT START function	0/1/2/3	0		2	num
Sdi	PERIODICAL CYCLE (folder with label "cLc") output On time	0...30.0	0		2	°C/°F
Con	output OFF time	0...250	0		2	min
CoF	ALARMS (folder with "AL" label) Alarm type. Parameter "HA1(2)" and "LA1(2)" modes, as temperature absolute values or as differential compared to the Setpoint. 0 = absolute value; 1 = relative value. Alarm Fan differential. Alarm differential.	0...250	0		2	min
Att	Power-on Alarm Override. Alarm exclusion time after instrument switch on, after a power failure.	Abs/reL	Abs		2	flag
AFd	(1) Setpoint Alarm Override. Exclusion alarm time until Setpoint is reached. 0 = disabled. If >0, an alarm occurs, if setpoint has not been reached after the time (hours) set by this parameter.	1.0...50.0	2.0		2	°C/°F
PAO (1)	temperature Alarm Override. Temperature alarm signal delay time.	0...10	0		1	hours
SAO	temperature Alarm Override. Polarity of alarm output.	0...10	0		1	hours
tAO (1)	0 = alarm active and output disabled; 1 = alarm active and output enabled.	0...250	0		1	min
AOP	FOLDER AVAILABLE ONLY IN LX MODELS COMMUNICATION (folder with "Add" label) dEA (1) dEvice Address. Device address: indicates the appliance address to the management protocol. dEvice Address. FAA (1) FAmily Address: indicates the appliance family to the management protocol.	nc/no	nc		2	flag
dEA (1)	(°) DISPLAY (folder with "diS" label) (keyboard) LOCK (set and keys). Keyboard locking. However, you can enter parameter programming	0...14	0		1	num
FAA (1)	modify them along with the status of this parameter in order to allow keyboard locking. y = yes; n = no PAssword 1. When enabled (value other than 0) it constitutes the access key for level 1 parameters. PAssword 2. When enabled (value different from 0) it represents the access key for level 2 parameters.	0...14	0		1	num
LOC	number display type. View with decimal point. y = yes; n = no	n/y	n		1	flag
PA1	CAlibration 1. Calibration 1. Positive or negative temperature value added to the value read by probe 1.	0...250	0		1	num
PA2****	CAlibration Intervention. Intervention on view offset, thermostat offset or both.	0...250	0		2	num
ndt	0 = modifies the temperature displayed only; 1 = adds to the temperature used by regulators, not to the temperature displayed, which stays unchanged; 2 = adds to the temperature displayed that is also used by regulators.	n/y	n		1	flag
CA1	Low display Label. Minimum value the instrument is able to display.	-30.0...30.0	0		1	°C/°F
CAI	High display Label. Maximum value the instrument is able to display.	0/1/2	0		2	num
LdL	display read-out. Select °C or °F for displaying the temperature read by the probe.	-328.0...HdL	*		2	°C/°F
HdL	PLEASE NOTE: the switch between °C and °F DO NOT modify setpoint, differential, etc. (for example set=10°C become 10°F). CONFIGURATION (folder with "CnF" label) Probe type selection, PTC or NTC.	LdL...1999	*		2	°C/°F
dro	PARAMETER VISIBLE ONLY ON PTC-NTC MODELS or Tcd/Tck models. Model Pc1000 works only on input Pt100 (34 wires) while models Tcj/Tck can function with input Pt100 on the basis of this parameter. Outputs link 0 = independents; 1 = related; 2 = Neutral Zone;	°C/°F	°C		1	flag
H00(1)(1)	delay time in activating the outputs after switch-on Time to enable keys, if these are configured for a specific function. For ESC, UP and DOWN keys configured for specific function (defrost, aux, etc) it set the elapsed time for the manual activation of the related function. aux function has a fixed time of 1 second Window Filter. -2=very fast; -1=fast; 0=normal; =slow; 2=very slow	PtC-Ntc / Pt1-JtC-HtC	PtC-Ntc*/Pt1-JtC-HtC*		1	flag
H01	key/input aux/door switch light active when instrument is off (but under tension)	0/1/2	0/1/2*		1	num
H02	key/input aux/door switch light active when instrument is off (but under tension)	0...15	5		2	sec
H05	Stand-by operating mode. 0=display switch off; 1= display on and loads stopped; 21= display off and loads stopped; Delay outputs from power-on. WARNING! If set = 0 it is not active; if set ≠0 output will not be activated before this time	-2/+1/0/1/2	0		2	°C/°F
H06	FOLDER AVAILABLE ONLY IN LX MODELS Configuring digital inputs.	n/y	y		2	flag
H08	0 = disabled; 1 = SOFT START; 2 = Offset Setpoint; 3 = outputs stopped; 4 = periodical cycle; 5 = auxiliary output; 6 = stand-by 7 = maintenance requested 8 = external alarm 9 = external alarm stop regulators	0/1/2	2		2	num
H10		0...250	0		1	min
H11		0...9	0		2	num

PAR.	DESCRIPTION	RANGE	DEFAULT*	VALUE*	LEVEL***	U.M.
H13 (°)	FOLDER AVAILABLE ONLY IN LX MODELS Polarity and Priority Digital Input no= normally open/ nc= normally closed / noP= normally open with Polarity / ncP= normally close with Polarity	no/nc/noP/ncP	no		2	num
H14 (°)	FOLDER AVAILABLE ONLY IN LX MODELS Delay Activation Digital Input	0...250	0		2	num
H21 (!)	Configurability digital output 1 (OUT1) 0 = disabled; 1 = on-off; 2 = PID. NOTE: IN this case OUT1 works in heating mode 3 = alarm; 4 = periodical cycle 5 = auxiliary/light 6 = stand-by	0..6	1		2	num
H22 (!)	Configurability digital output 2. (OUT2) Same as H21. 2 = PID. NOTE: IN this case OUT1 works in cooling mode PLEASE NOTE: PID temperature control acts only on OUT 1	0..6	1		2	num
H31 (!)	Configurability UP key. 0 = disabled; 1 = SOFT START; 2 = Offset Setpoint; 3 = outputs stopped; 4 = periodical cycle; 5 = auxiliary output; 6 = stand-by 7 = maintenance requested	0...7	0		2	num
H32 (!)	Configurability DOWN key. Same as H31.	0..7	0		2	num
H33 (!)	Configurability ESC key. Same as H31. (2 = Offset Setpoint; default)	0..7	0		2	num
rEL	release firmware. Device version: read only parameter.	/	/		1	/
tAb	tAble of parameters. Reserved: read only parameter.	/	/		1	/

label PA2

Inside CnF folder it is possible to reach all level 2 parameters from label PA2 by pressing the “set” button
SEE 2) Level 2 Parameters paragraph

UL	COPY CARD (folder with “Fpr”label) Up load. Programming parameter transfer from instrument to Copy Card.	/	/		1	/
dL	Down load. Programming parameter transfer from Copy Card to instrument	/	/		1	/
Fr	Format. Erasing all data in the copy card. PLEASE NOTE using “Fr” parameter (copy card formatting) the data within the copy card will be lost permanently. The operation cannot be cancelled. After using the copy Card device the controller must be switch off and switch on again	/	/		2	/

FUNCTIONS (folder with label “FnC”)

Inside FnC folder (last visible folder from Programming Menu) there are available some functions that could be enabled by “set” button
SEE FUNCTIONS paragraph

- (1) Referred exclusively to high and low temperature alarms
(2) Positive values: active input when the contact is closed; negative values: 1= Active when contact is open
(°) parameters set to 0 (default) every time the instrument is turned on
(°°) parameters visible only in LX models
(§) **PARAMETER VISIBLE ONLY ON PTC-NTC MODELS or Tcd/Tck models. Model Pc1000 works only on input Pt100 (34 wires) while models Tcj/Tck can function with input Pt100 on the basis of this parameter.**

PARAMETERS with different ranges or default values for model PTC-NTC or Pt100-TC

parameter	PTC-NTC range	PTC-NTC default	Pt100-TC range	Pt100-TC default
HA1	LA1...350.0	140	LA1...1999	*
LA1	-99.9...HA1	-50	-328...HA1	*
dLt	0...100	0	0...100	10
AtO	0...10	0	0...10	1
LdL	-67.0...HdL	-50	-328...HdL	*
HdL	LdL...302.0	140	LdL...1999	*
H00 (§)	PtC/NtC	PtC/NtC*	Pt1/JtC/HtC	Pt1/JtC/HtC*

RANGE column: for few parameters default value is different depending on model PTC/NTC or Pt100-TC. See next table.

- * **DEFAULT column: for parameters highlighted with * default value depending on model.**
** VALUE column: to be filled manually, with custom settings (if different from the default value).
*** LEVEL column: indicates the level of visibility for parameter that can be accessed by a PASSWORD (see the related paragraph)
**** PA2 is visible (it will be requested, if specified) at level 1 in **CnF folder** and can be set (it can be modified) at level 2 in **diS folder**

(!) WARNING!

- If one or more of these parameters highlighted with (!) are modified, the controller must be switched off and switched on again to ensure correct operation.
- It is strongly recommended, anyway to switch off and switch on again the controller anytime parameters have been changed to prevent malfunctioning on configuration and/or ongoing timings

Programming Menu Diagram

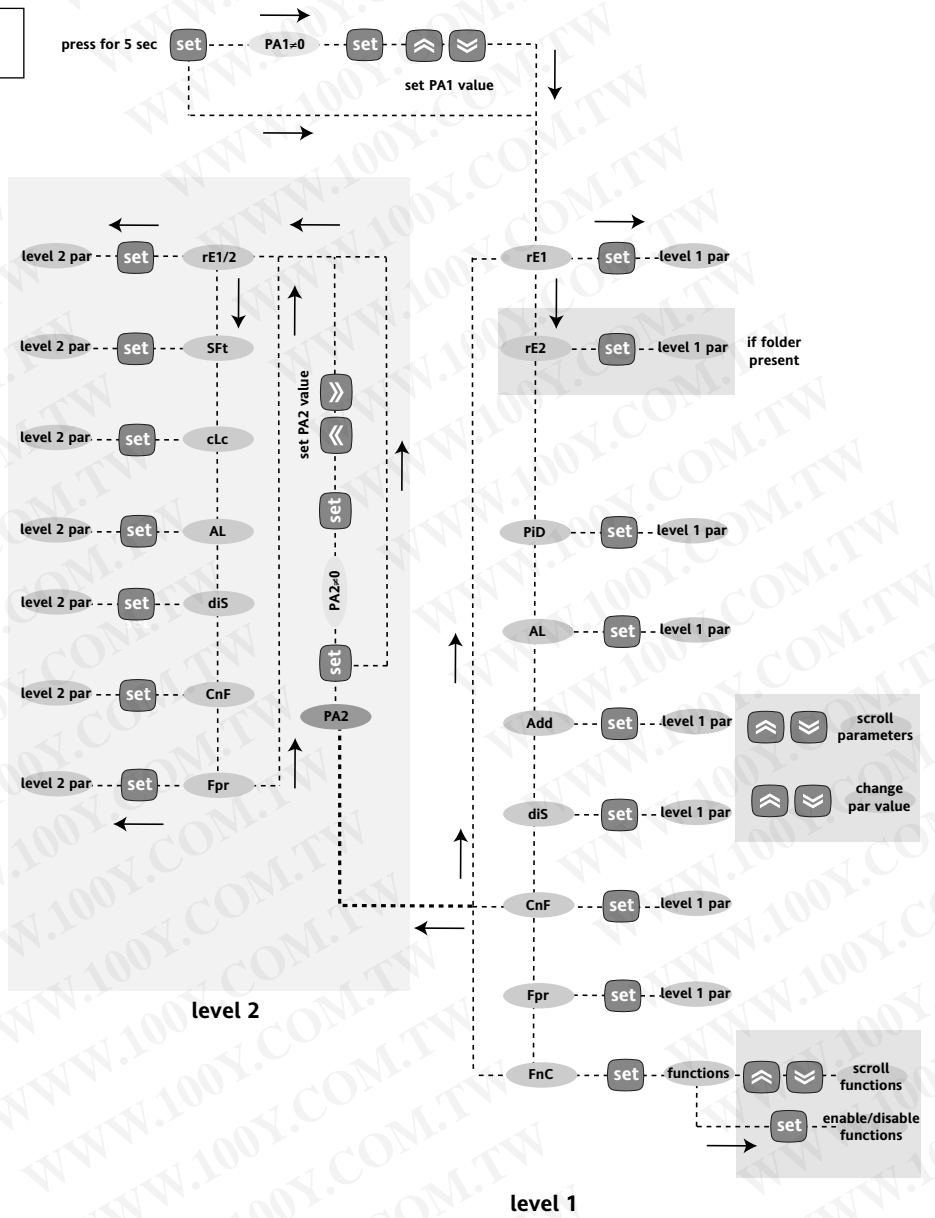

PARAMETERS

Level 1 folders Level 2 folders

rE1	rE1
rE2	rE2
PID	SFt
	cLc
AL	AL
Add	
diS	diS
CnF	CnF
Fpr	FPr

FUNCTIONS

FnC

Status Machine Diagram

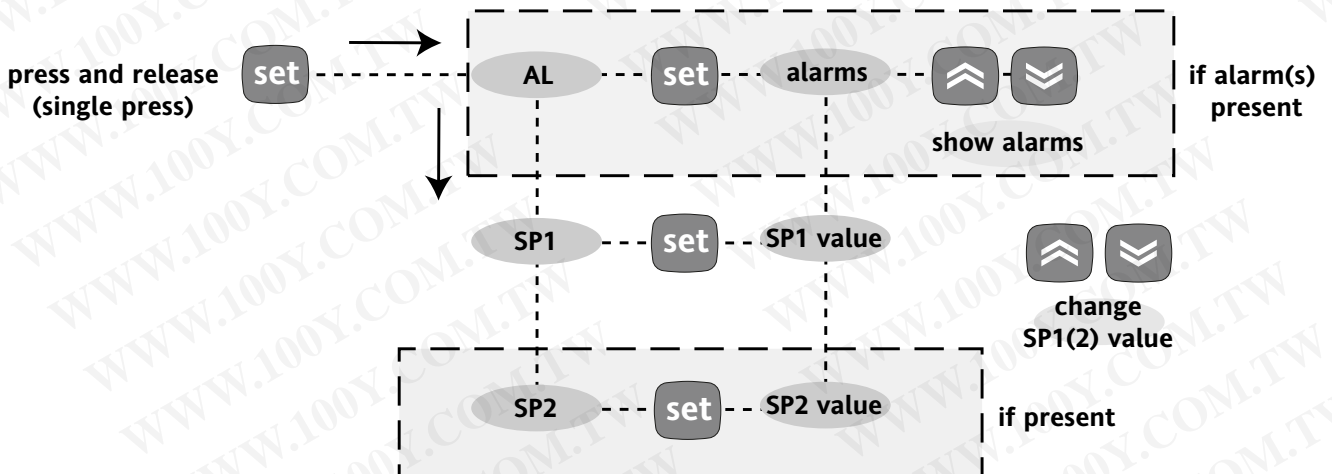

Duty Cycle Diagram

parameters On1(On2) ed OF1(OF2) programmed for the duty cycle

On1 (On2)	OF1 (OF2)	regulator output
0	0	OFF
0	>0	OFF
>0	0	ON
>0	>0	D.C.

When the analogue input detects an error condition:

- the code E1 is displayed
- the regulator is activated as indicated by the "On1 (On2)" and "OF1(OF2)" parameters if programmed for the duty cycle

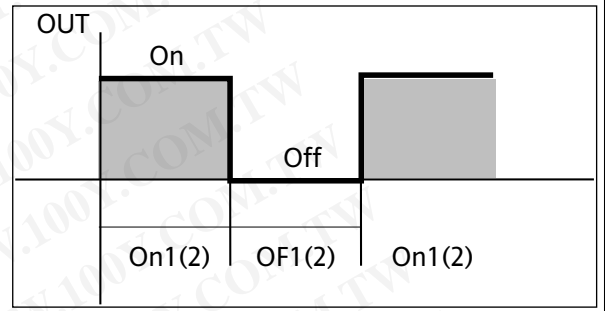

ON-OFF Regulation Diagram

ON-OFF regulation diagram independent. The outputs regulate as they as completely independent

HC1	HC2	H01	regulation type
H	C	0	independents setpoints
H	C	1	related setpoints
-	-	2	Neutral Zone

PLEASE NOTE:

- for 1 & 2 examples with HC1=H and HC2=C
- for 3 HC1 and HC2 are ignored

ON-OFF regulation diagram related. Setpoint 2 SP2 works depending on Setpoint SP1

ON-OFF regulation diagram Neutral Zone. NOTE: if dF1 and dF2 are both =0 outputs will open when they reach SP1 value

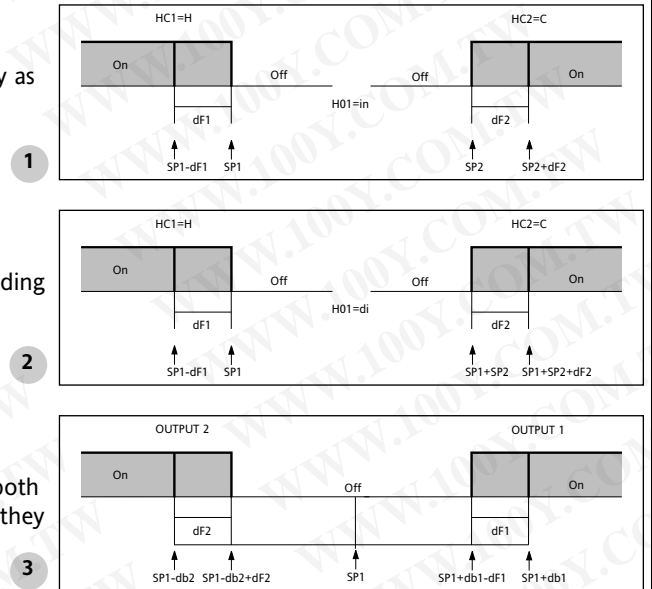

Max/Min. Alarms Diagram (Maximum and Minimum Temperature Alarms)

The maximum alarm will become when the probe temperature will be:

- (1) higher o equal to HA1(2) if Att=Abs(olute)
- (2) higher o equal set + HA1(2) if Att=rEL(ative)

- if Att=Abs(olute) HA1(2) should be with sign;
- if Att=rEL(ative) HA1(2) should be only positive

The minimum alarm will become when the probe temperature will be::

- (1) lower or equal to LA1(2) if Att=Ab(solute)
- (2) lower or equal to set + LA1(2) if Att=rEL(ative)

- se Att=Ab(solute) LA1(2) should be with sign;
- se Att=rEL(ative) LA1(2) should be only negative

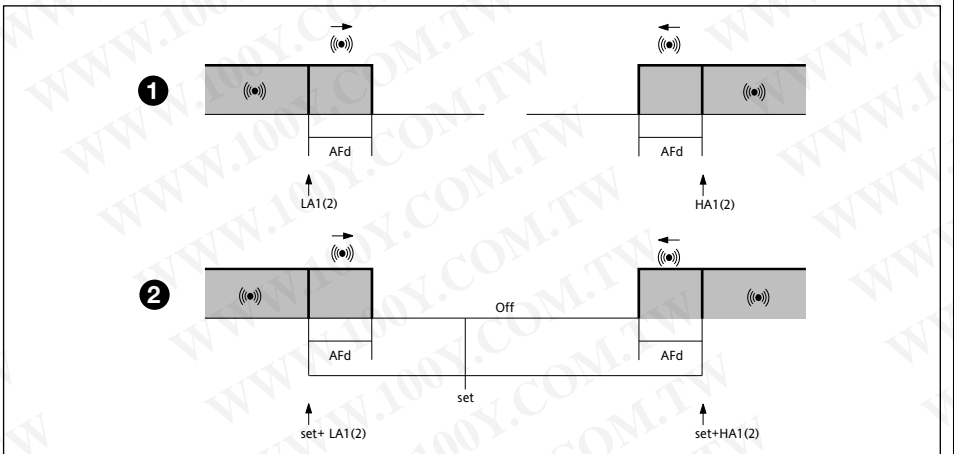

The maximum alarm will ends when the probe temperature will be:

- (1) lower or equal to HA1(2) - AFD if Att=Abs(olute)
- (2) lower or equal to set + HA1(2) - AFD if Att=rEL(ative)

The minimum alarm will ends when the probe temperature will be:

- (1) higher o equal LA1(2) + AFD if Att=Abs(olute)
- (2) higher o equal a set + LA1(2) + AFD if Att=rEL(ative)

***PLEASE NOTE : if Att=rEL(ative) LAL should be only negative: so set+LAL<set because set+(-|LAL|)=set-|LAL|**

NTC-PTC wiring diagram

TERMINALS (12V and 230 V versions)

1 - 2	N.O. regulator 1 relay (OUT1)
1 - 3	N.C. regulator 1 relay (OUT1)
4 - 5	N.O. regulator 2 relay (OUT2)
6 - 7	power supply 1.5 VA max. (12V version) power supply 3 VA max. (230V version)
8 - 10	Probe 1 input (regulation)
A	TTL input for Copy Card and connection with TelevisSystem
8 - 11	FOR LX VERSIONS ONLY Digital Input (D.I.)

NOTE:

- Default utility settings
- refer to label on instrument for relay capacity.

The diagram shows only the 12 and 230V power supplies and the relays with capacity 8(3)A 250V

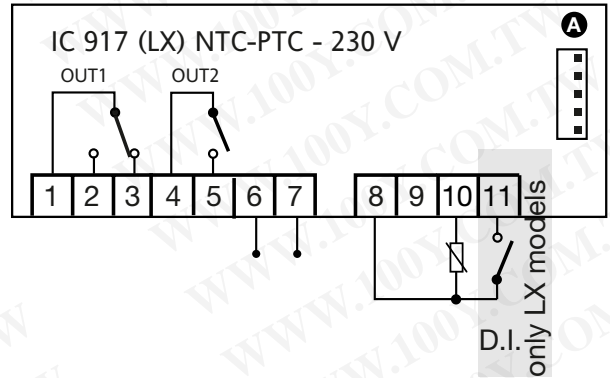
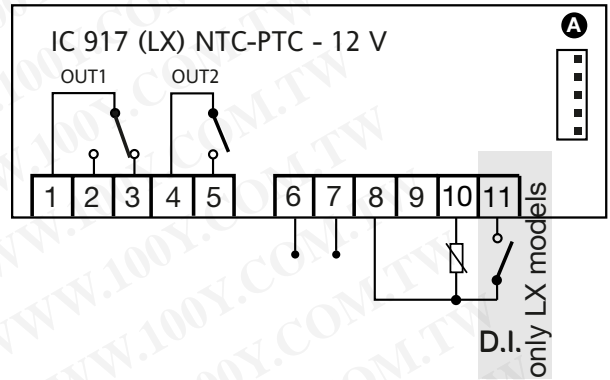

Pt100-TC wiring diagram

TERMINALS (12V and 230 V versions)

1 - 2	N.O. regulator 1 relay (OUT1)
4 - 5	N.O. regulator 2 relay (OUT2)
6 - 7	power supply 1.5 VA max. (12V version) power supply 3 VA max. (230V version)
*10-11-12	Pt100 three wire probe input Pb1
*11-12	Tcl/Tck input (11: +; 12:-)
A	TTL input for Copy Card and connection with TelevisSystem
8 - 9	FOR LX VERSIONS ONLY Digital Input (D.I.)

NOTE:

- Default utility settings
- refer to label on instrument for relay capacity.
- **Check polarity of probe insertion.**

The diagram shows only the 12 and 230V power supplies and the relays with capacity 8(3)A 250V

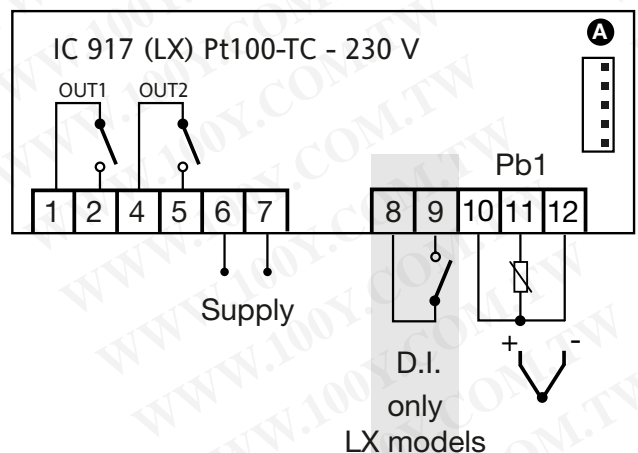
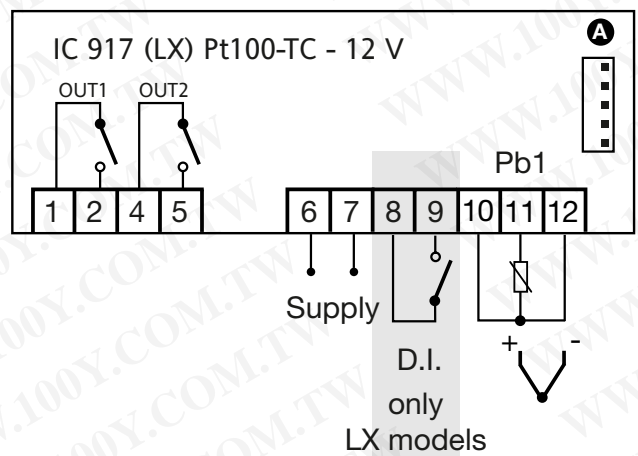

Eliwell & Controlli s.r.l.
Via dell'Industria, 15 Zona Industriale Paludi
32010 Pieve d'Alpago (BL) ITALY
Telephone +39 0437 986111
Facsimile +39 0437 989066
Internet <http://www.eliwell.it>

Technical Customer Support:
Email: techsuppeliwell@invensys.com
Telephone +39 0437 986300

Invensys Controls Europe
Part of the Invensys Group

12/2004 eng
cod. 9IS43013

