



35W Single Output Switching Power Supply

NES-35 series



■ Features :

- Universal AC input/Full range
- Protections: Short circuit / Overload / Over voltage
- Cooling by free air convection
- 100% full load burn-in test
- 2 years warranty

勝特力材料 886-3-5753170
 勝特力电子(上海) 86-21-34970699
 勝特力电子(深圳) 86-755-83298787
[Http://www.100y.com.tw](http://www.100y.com.tw)



SPECIFICATION

MODEL	NES-35-5	NES-35-12	NES-35-15	NES-35-24	NES-35-48	
OUTPUT	DC VOLTAGE	5V	12V	15V	24V	48V
	RATED CURRENT	7A	3A	2.4A	1.5A	0.8A
	CURRENT RANGE	0 ~ 7A	0 ~ 3A	0 ~ 2.4A	0 ~ 1.5A	0 ~ 0.8A
	RATED POWER	35W	36W	36W	36W	38.4W
	RIPPLE & NOISE (max.) Note.2	80mVp-p	120mVp-p	150mVp-p	200mVp-p	240mVp-p
	VOLTAGE ADJ. RANGE	4.75 ~ 5.5V	10.8 ~ 13.2V	13.5 ~ 16.5V	21.6 ~ 26.4V	43.2 ~ 52.8V
	VOLTAGE TOLERANCE Note.3	±2.0%	±1.0%	±1.0%	±1.0%	±1.0%
	LINE REGULATION Note.4	±0.5%	±0.5%	±0.5%	±0.5%	±0.5%
	LOAD REGULATION Note.5	±0.5%	±0.5%	±0.5%	±0.5%	±0.5%
	SETUP, RISE TIME	500ms, 30ms/230VAC 1200ms, 30ms/115VAC at full load				
HOLD UP TIME (Typ.)	50ms/230VAC 10ms/115VAC at full load					
INPUT	VOLTAGE RANGE	85 ~ 264VAC 120 ~ 370VDC				
	FREQUENCY RANGE	47 ~ 63Hz				
	EFFICIENCY (Typ.)	78%	81%	83%	85%	86%
	AC CURRENT (Typ.)	0.75A/115VAC 0.5A/230VAC				
	INRUSH CURRENT (Typ.)	COLD START 45A				
LEAKAGE CURRENT	<2mA / 240VAC					
PROTECTION	OVERLOAD	110 ~ 150% rated output power Protection type : Hiccup mode, recovers automatically after fault condition is removed				
	OVER VOLTAGE	5.75 ~ 6.75V	13.8 ~ 16.2V	17.25 ~ 20.25V	27.6 ~ 32.4V	55.2 ~ 64.8V
ENVIRONMENT	WORKING TEMP.	-20 ~ +60°C (Refer to output load derating curve)				
	WORKING HUMIDITY	20 ~ 90% RH non-condensing				
	STORAGE TEMP., HUMIDITY	-40 ~ +85°C, 10 ~ 95% RH				
	TEMP. COEFFICIENT	±0.03%/°C (0 ~ 45°C)				
	VIBRATION	10 ~ 500Hz, 2G 10min./1cycle, period for 60min. each along X, Y, Z axes				
SAFETY & EMC (Note 6)	SAFETY STANDARDS	UL60950-1, CB(IEC60950-1) Approved				
	WITHSTAND VOLTAGE	I/P-O/P:3KVAC I/P-FG:1.5KVAC O/P-FG:0.5KVAC				
	ISOLATION RESISTANCE	I/P-O/P, I/P-FG, O/P-FG:100M Ohms/500VDC				
	EMI CONDUCTION & RADIATION	Compliance to EN55022 (CISPR22) Class B				
	HARMONIC CURRENT	Compliance to EN61000-3-2,-3				
OTHERS	EMTBF	394Khrs min. MIL-HDBK-217F (25°C)				
	DIMENSION	99*97*36mm (L*W*H)				
	PACKING	0.36Kg; 45pcs/17.2Kg/0.93CUFT				
NOTE	1. All parameters NOT specially mentioned are measured at 230VAC input, rated load and 25°C of ambient temperature. 2. Ripple & noise are measured at 20MHz of bandwidth by using a 12" twisted pair-wire terminated with a 0.1uF & 47uF parallel capacitor. 3. Tolerance : includes set up tolerance, line regulation and load regulation. 4. Line regulation is measured from low line to high line at rated load. 5. Load regulation is measured from 0% to 100% rated load. 6. The power supply is considered a component which will be installed into a final equipment. The final equipment must be re-confirmed that it still meets EMC directives.					

Mechanical Specification

Case No. 905 Unit:mm

勝特力材料 886-3-5753170
 勝特力电子(上海) 86-21-34970699
 勝特力电子(深圳) 86-755-83298787
[Http://www.100y.com.tw](http://www.100y.com.tw)

Terminal Pin. No Assignment

Pin No.	Assignment	Pin No.	Assignment
1	AC/L	4	DC OUTPUT -V
2	AC/N	5	DC OUTPUT +V
3	FG \perp		

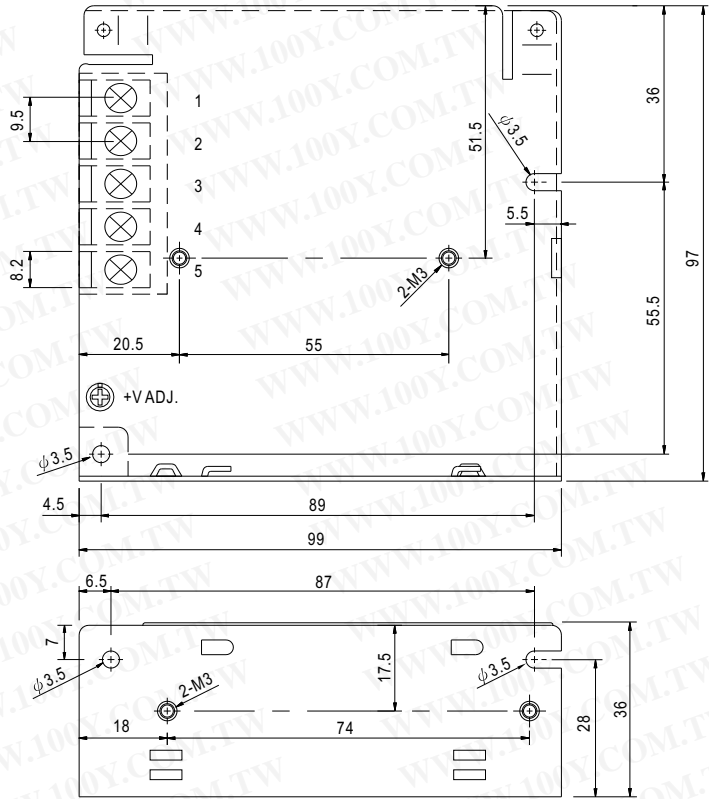

Block Diagram

fosc : 60KHz

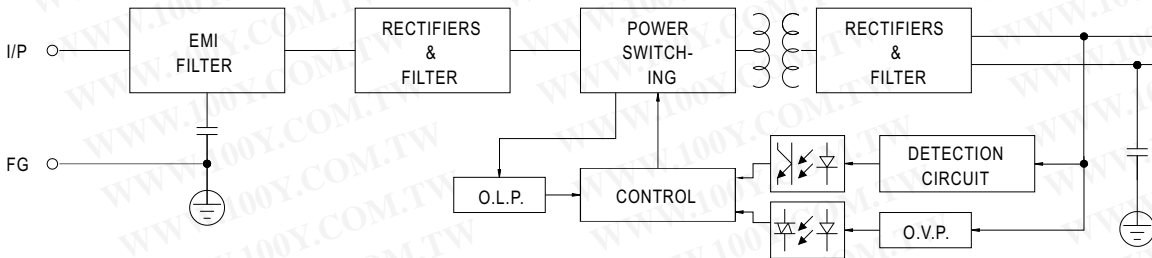

Derating Curve

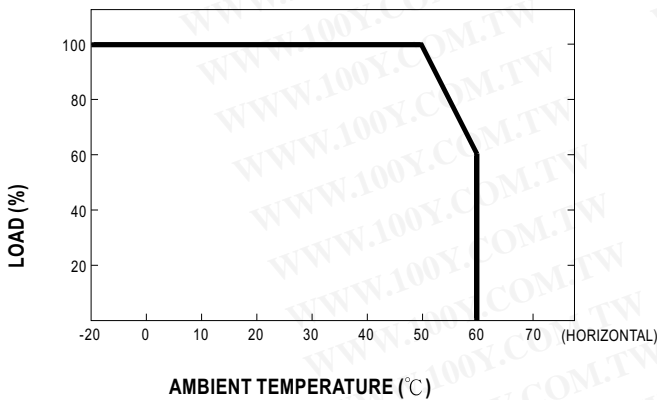

Output Derating VS Input Voltage

