

Part No:

YLL-FFW3FIF114G-S

勝特力材料 886-3-5753170  
勝特力电子(上海) 86-21-34970699  
勝特力电子(深圳) 86-755-83298787  
[Http://www.100y.com.tw](http://www.100y.com.tw)

## Features:

- \* High intensity Polygonal LED lamp
- \* 平头 round shape
- \* UV resistant epoxy

## Applications:

- \* LED Lighting
- \* Automotive Lighting application

## Absolute Maximum Ratings (Ta=25°C)

Parameter	Symbol	Max	Unit
Power Dissipation	Ps	100	mW
Peak Forward Current	$I_{FF}$	20	mA
Continuous Forward Current	$I_F$	20	mA
Reverse Voltage	Vs	5	V
Operating Temperature Range	Topr	-30°C to +80°C	
Storage Temperature Range	Tstg	-40°C to +100°C	
Lead Soldering Temperatur $\Delta$	Tsol	260	°C

## Package Dimensions

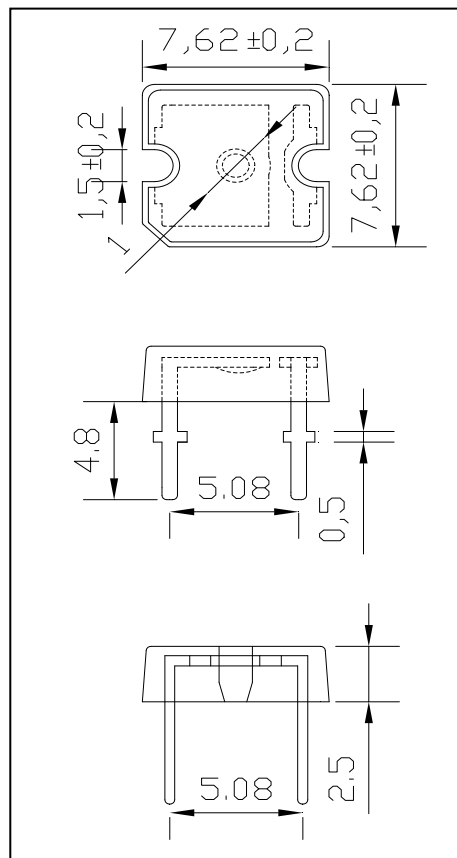

Unit : mm

Tolerance are  $\pm 0.2$ , unless note otherwise

\* Duty ratio max 1/10 Pulse Width max. 0.1ms;

$\Delta$  At the position of 4mm from the bottom of the package within 5 seconds.

Part No.	Material	Lens	Emitting color	Forward voltage(V)		Luminous Intensity(M CD)		Dominant Wavelength(k)		Viewing Angle (2θ <sub>1/2</sub> )
				Min	Max	Min	Max	Min	Max	
YLL-FFW3FIF114G-S	AlGaIn P	Water Clear	White	3.0	3.4	500	700	15000	20000	180

## BIN Table: (Test at 20 mA)

VF (v)	
Code	Range
1	3.0-3.2
2	3.2-3.4

IV (mcd)	
Code	Range
1	500-700

Wd (K)	
Code	Range
W1	15000-20000

\* Luminous Intensity Measure tolerance are 15%

1. Static Electricity and surge damages the LEDs. It is recommended to use a wrist band or anti-electrostatic glove when handling the LEDs. All devices、Equipment and machinery must be properly grounded.
2. When inspecting own final products on which LEDs were mounted, It is easy to find static-damaged LEDs by light emission test at lower current (below 1mA is recommended) .
3. Damaged LEDs will show some unusual characteristics such as leak current remarkably increases, starting forward voltage becomes lower, or the LEDs get unlighted at the low current.

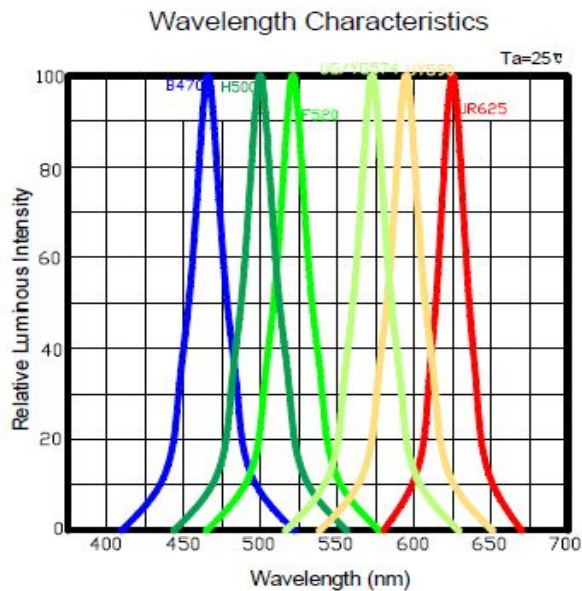
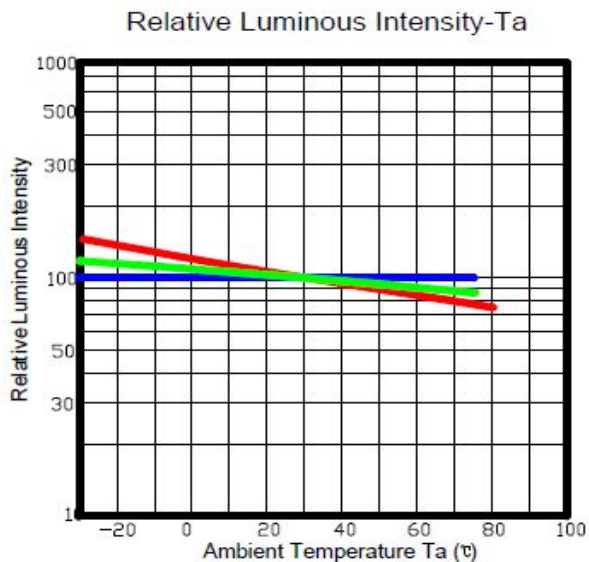
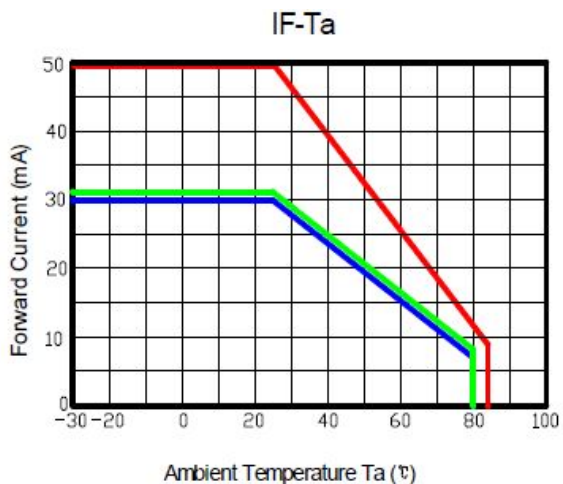
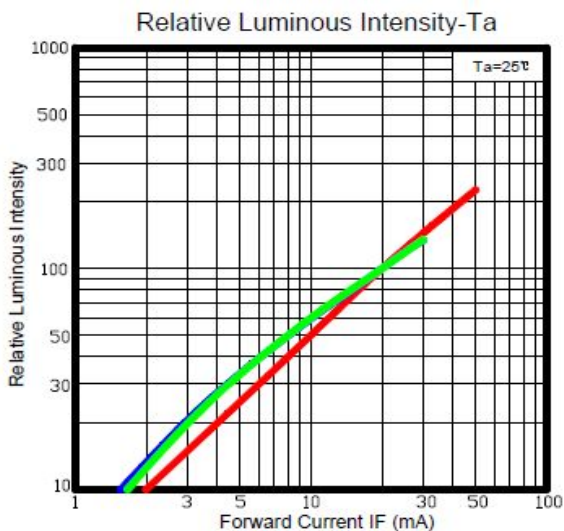
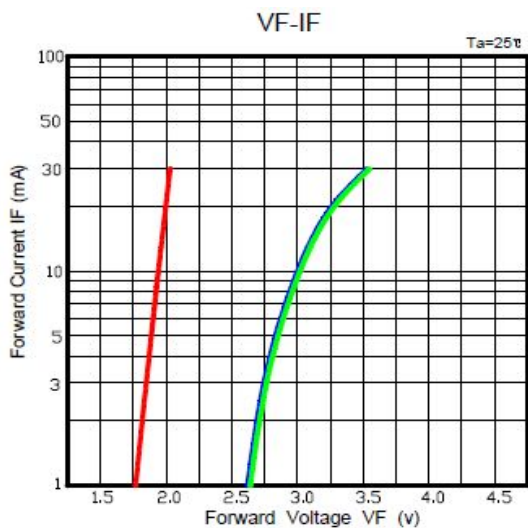

Classification	Test Item	Test Conditions	Sample Size	Num of Damaged	Reference Standard
Endurance Test	Operating Life	$I_F=30mA$ 1000Hrs	22	0	MIL-STD-750:1026 MIL-STD-202:107D JIS C 7021:B-4
	High Temp. High Humidity Storage	$85\pm5^\circ C$ 85-90% RH 1000Hrs	100	0	MIL-STD-202:103D JIS C 7021:B-11
	Hi-Temp. Storage	$100\pm5^\circ C$ 1000Hrs	100	0	MIL-STD-750:2031 MIL-STD-202:210A JIS C 7021:B-10
	Low-Temp. Storage	$-55\pm5^\circ C$ 1000Hrs	100	0	JIS C 7021:B-12
Environmental Test	Temperature Cycling	$-40\pm5^\circ C$ 30min Room Temp. 5min $100\pm5^\circ C$ 30min 100 Cycles	100	0	MIL-STD-750:1051 MIL-STD-202:107D JIS C 7021:A-4
	Thermal Shock	$-30\pm5^\circ C$ 5min $100\pm5^\circ C$ 5min 100 Cycles	100	0	MIL-STD-750:1051 MIL-STD-202:107D JIS C 7021:A3
	Solderability	$230\pm5^\circ C$ Dwell Time $\leq 5sec$	22	0	MIL-STD-202:208D MIL-STD-750:2026 MIL-STD-883:2003 JIS C 7021:A-2
	Solder Resistance	$260\pm5^\circ C$ $10\pm 1sec$	22	0	MIL-STD-750:2031 MIL-STD-202:210A JIS C 7021:A-1

勝特力材料 886-3-5753170  
 勝特力电子(上海) 86-21-34970699  
 勝特力电子(深圳) 86-755-83298787  
[Http://www.100y.com.tw](http://www.100y.com.tw)

### Criteria for Judging The Damage:

Item	Symbol	Test Conditions	Criteria for Judgment	
			Min	Max
Forward Voltage	$I_F$	$I_F = 20mA$	-	U. S. L*1.1
Reverse Current	$I_R$	$V_R = 5V$	-	U. S. L*2.0
Luminous Intensity	$I_V$	$I_F = 20mA$	L. S. L*0.7	-

PS: U. S. L. :Upper Standard Level L. S. L. :Lower Standard Level