

Transparent Object Detection

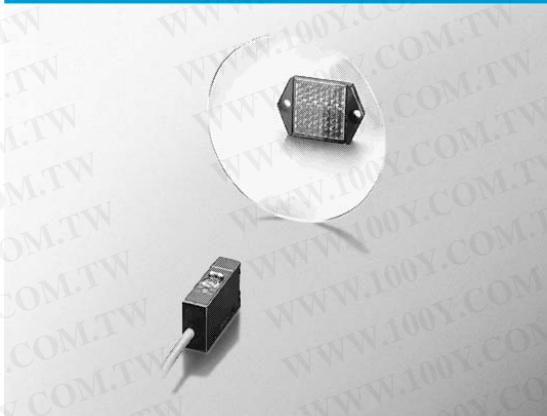

HPA-G Series

Ideal for the detection of bottles, clear sheets, and other highly transparent workpieces.



- Reflector type for the detection of transparent bodies
- Sensitivity can be easily fine-tuned by a 2-turn control with indicators
- Automatic pulse phase shift system effectively reduces mutual interference
- Optical axis can be easily adjusted by red LED
- Temperature drift is minimal due to built-in temperature compensation circuit



CLICK

ORDER GUIDE

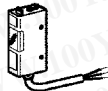
Type	Scanning method	Scanning distance	Light ON/dark ON selectable	Sensitivity adjustment	Supply voltage	Output mode	Catalog listing
Horizontal type 	Reflector type	50cm	<input type="radio"/>	<input type="radio"/>	10 to 30 Vdc	NPN open collector	HPA-G11
Vertical type 							HPA-G21

APPLICATION EXAMPLE

- Detection of liquid crystal glass

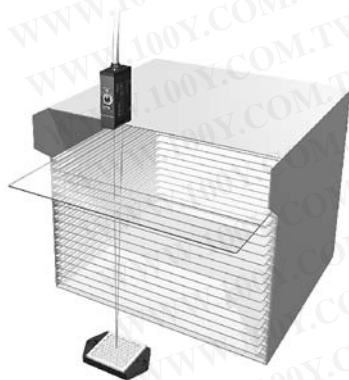





勝特力材料 886-3-5753170
 勝特力电子(上海) 86-21-34970699
 勝特力电子(深圳) 86-755-83298787
[Http://www.100y.com.tw](http://www.100y.com.tw)

SPECIFICATIONS

Scanning method	Reflector type
Type	Transparent object detection type
Catalog listing	HPA-G11, HPA-G21
Supply voltage	10 to 30Vdc (ripple 10% max.)
Current consumption	40mA max.
Scanning distance	50 cm (reflector FE-RR15 used)
Detection object	Opaque object, semi-transparent type 45mm dia. min. (reflector FE-RR15 used)
Standard detection object	—
Scanning angle	Body 1 to 5°, reflector 40°
Differential travel	—
Operation mode	Light ON/dark ON switch selectable
Output mode	NPN transistor open collector
Control output	Switching current: 100mA max. (resistive load), Dielectric strength: 30V max., Voltage drop: 1V max. (at 100mA switching current), with output short-circuit protection circuit
Response time	0.5ms max. for operation and recovery
Sensitivity adjustment	2-turn control with indicator
Light emitter	LED
Indicators	Incoming light indicator: red (light ON), Stability indicator: green (ON during stable LO/ON during stable dark ON)
Ambient light immunity	Incandescent lamp: 5,000lux max., Sunlight: 20,000lux max.
Operating temperature range	−25 to +60°C
Storage temperature range	−40 to +70°C
Humidity range	35 to 85% RH (condensation not allowed)
Insulation resistance	Min. 20MΩ (at 500Vdc)
Dielectric strength	1,000Vac (50/60 Hz) for 1 minute between case and electrically live metals
Vibration resistance	10 to 55Hz, 1.5mm peak-to-peak amplitude, 2hrs in X, Y and Z directions
Shock resistance	490m/s ² 10 times in X, Y and Z directions
Protective structure	IP67 (IEC standard)
Wiring method	Pre-leaded
Weight	Approx. 55g (body only with 2m cable)
Circuit protection	Power ON/OFF malfunction prevention circuit (approx. 100ms), reverse connection protection circuit

ACCESSORIES (sold separately)

Name	Shape	Description	Catalog listing	Applicable model
Small reflector for polarized retroreflective model		Small type for when there is no space to attach the reflector Sold separately from HPA-P□□ , HPA-F□□ and HPA-G□□ .	FE-RR15	HPA-P□□, HPA-F□□ HPA-G□□
Reflector for polarized retroreflective model		Sold separately from HPA-P□□ , HPA-F□□ and HPA-G□□ .	FE-RR8	
Vertical model mounting bracket		—	HPA-B02	All vertical models
Cover mounting bracket		—	HPA-B03	All models

勝特力材料 886-3-5753170
 勝特力电子(上海) 86-21-34970699
 勝特力电子(深圳) 86-755-83298787
[Http://www.100y.com.tw](http://www.100y.com.tw)

CHARACTERISTICS DIAGRAMS

- Excess gain (light receiving level margin)
- Horizontal reflector

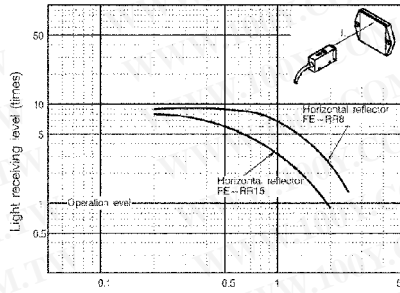

- Vertical reflector

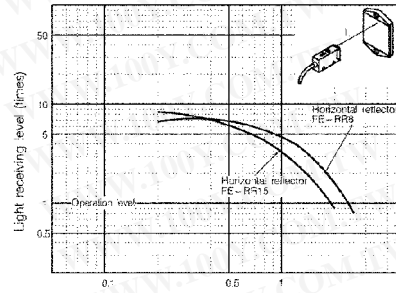

- Parallel motion characteristics
- Horizontal direction

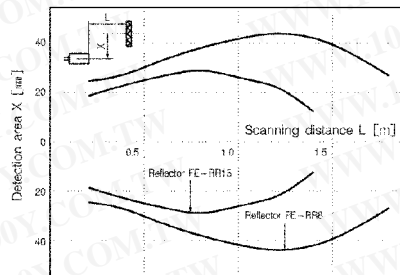

- Vertical direction

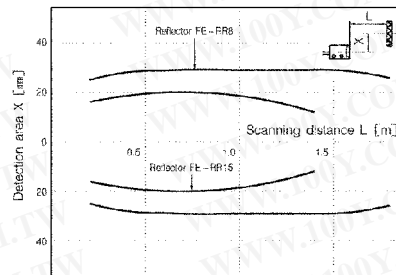

EXTERNAL DIMENSIONS

(unit: mm)

● HPA-G11

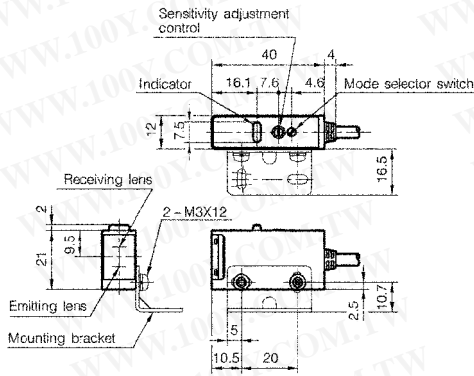

Note: PVC insulated cable (oil-proof 0.2mm²) 4.2dia.
Standard cable length 2m (pre-leaded)
Cable color: Gray

● HPA-G21

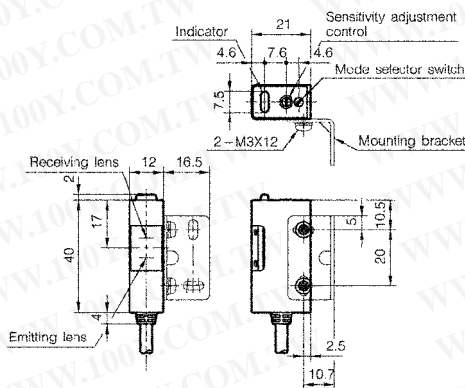

Note: PVC insulated cable (oil-proof 0.2mm²) 4.2dia.
Standard cable length 2m (pre-leaded)
Cable color: Gray

勝特力材料 886-3-5753170
勝特力电子(上海) 86-21-34970699
勝特力电子(深圳) 86-755-83298787
[Http://www.100y.com.tw](http://www.100y.com.tw)

● Brackets

- Mounting bracket **HPA-B01** (standard accessory)

(when attached to horizontal models)

(when attached to vertical models)

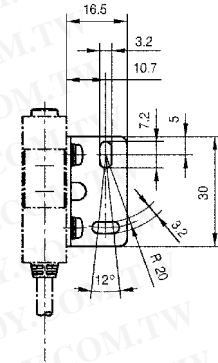
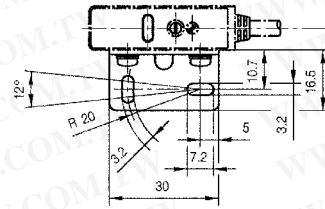
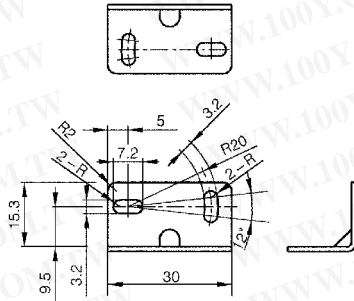

- Vertical mounting bracket **HPA-B02** (sold separately)

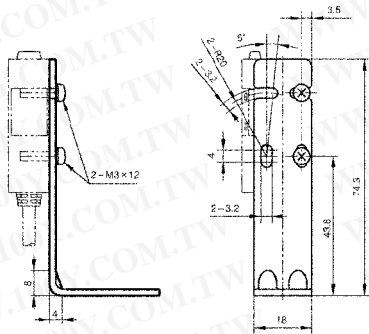
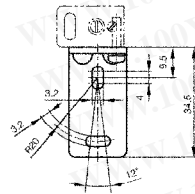

- Cover mounting bracket **HPA-B03** (sold separately)

(when attached to horizontal models)

(when attached to vertical models)

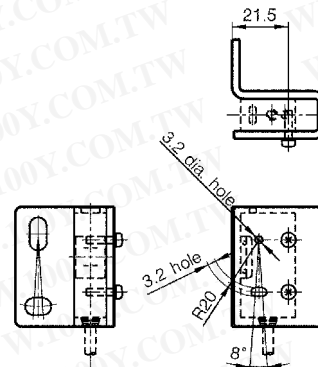
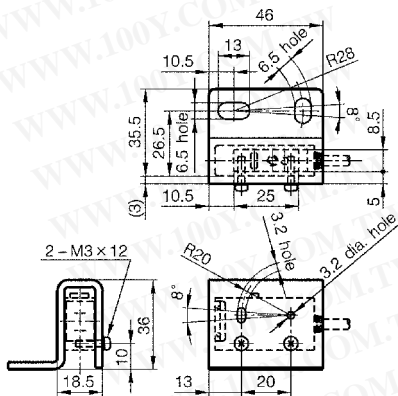

勝特力材料 886-3-5753170
 勝特力电子(上海) 86-21-34970699
 勝特力电子(深圳) 86-755-83298787
[Http://www.100y.com.tw](http://www.100y.com.tw)

- Reflector
- Reflector FE-RR8 (sold separately)

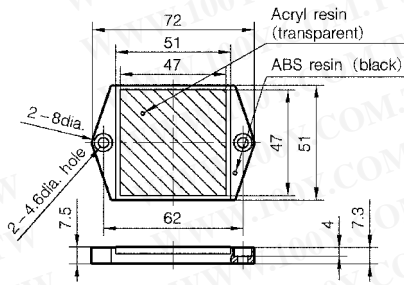

- Small reflector FE-RR15 (sold separately)

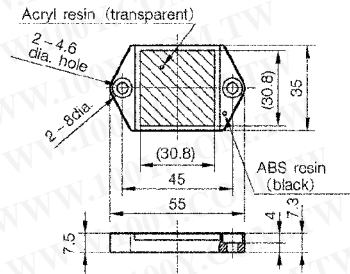

OUTPUT CIRCUIT

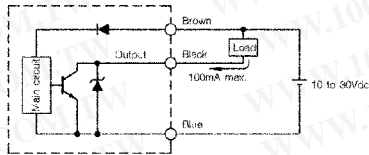

勝特力材料 886-3-5753170
 勝特力电子(上海) 86-21-34970699
 勝特力电子(深圳) 86-755-83298787
[Http://www.100y.com.tw](http://www.100y.com.tw)