

LT022PD

Features

- Uses single positive power supply drive
- Low noise S/N: -60 dB (according to measurement method Fig 27-2)
- Wavelength: 780nm
- Single transverse mode

Applications

- CD players
- CD-ROMs
- Information processing equipment

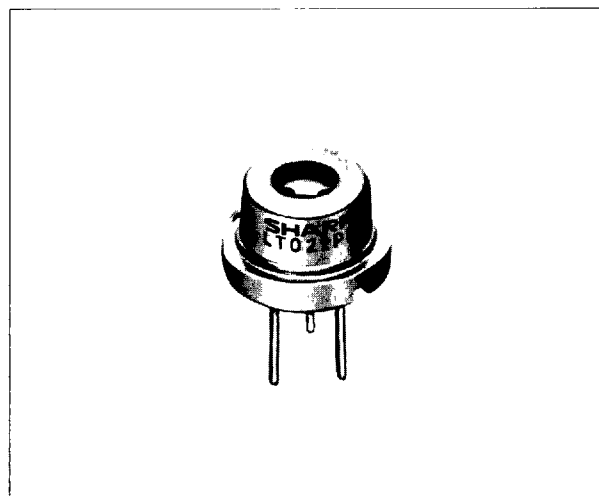

Absolute Maximum Ratings

(T_c = 25°C)

Parameter	Symbol	Ratings	Units
Optical power output	P _o	5	mW
Reverse voltage	Laser PIN V _R	2	V
		30	
Operating temperature* ¹	T _{opr}	-10 to +60	°C
Storage temperature* ¹	T _{stg}	-40 to +85	°C

*1 Case temperature

Electro-optical Characteristics*¹

(T_c = 25°C)

Parameter	Symbol	Condition	Ratings			Units		
			MIN	TYP	MAX			
Threshold current	I _{th}	—	—	50	80	mA		
Operating current	I _{op}	P _o = 3mW	—	65	100	mA		
Operating voltage	V _{op}	P _o = 3mW	—	1.75	2.2	V		
Wavelength* ²	λ _p	P _o = 3mW	770	780	795	nm		
Monitor current	I _m	P _o = 3mW V _R = 15V	—	0.4	—	mA		
Radiation characteristics	Angle* ³	Parallel to junction	θ	P _o = 3mW	8.5	11	16	deg
		Perpendicular to junction	θ _⊥	P _o = 3mW	25	35	48	deg
	Ripple	—	P _o = 3mW	—	—	±20	%	
Emission point accuracy	Angle	—	Δφ	P _o = 3mW	—	—	±2	deg
		—	Δφ _⊥	P _o = 3mW	—	—	±3	deg
	Position	—	Δx, Δy, Δz	—	—	—	±80	μm
Differential efficiency	η	2mW I _F (3mW) - I _F (1mW)	—	0.1	0.25	0.6	mW/mA	

*1 Initial value

*3 Angle at 50% peak intensity (full width at half-maximum)

*2 Single transverse mode

Electrical Characteristics of Photodiode

(T_c = 25°C)

Parameter	Symbol	Condition	Ratings			Units
			MIN	TYP	MAX	
Sensitivity	S	V _R = 15V	—	0.13	—	mA/mW
Dark current	I _D	V _R = 15V	—	—	150	nA
Terminal capacitance	C _t	V _R = 15V	—	18	—	pF

Common Data

Fig. 94-1 Optical Power Output Dependence of Far-Field Pattern

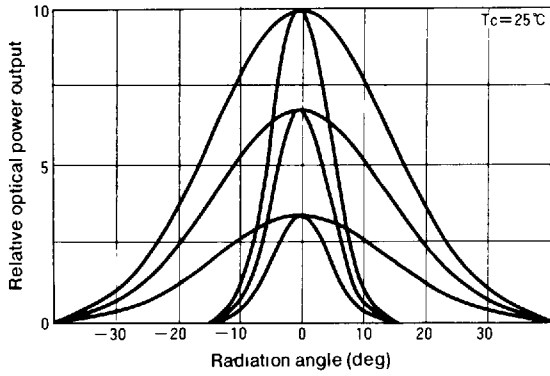

Fig. 94-4 Coupling Efficiency

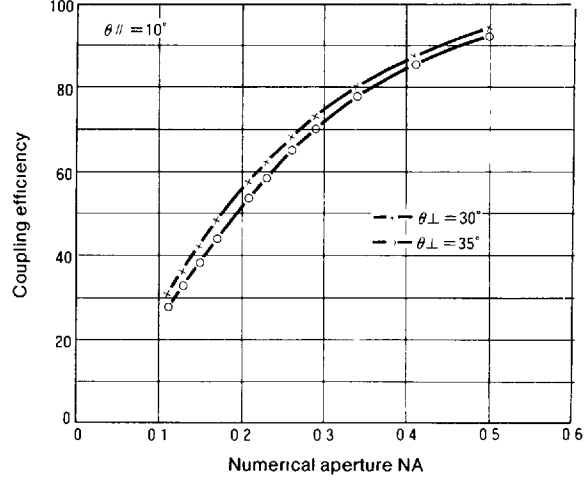

Fig. 94-2 Polarization Ratio vs. Optical Power Output (LT026 series, LT023 series)

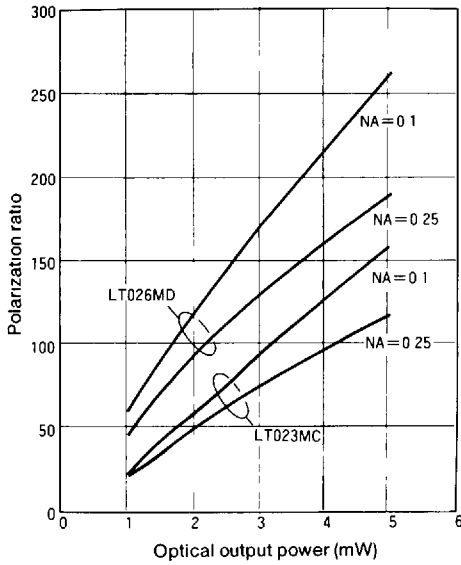

Fig. 94-5 Frequency Response

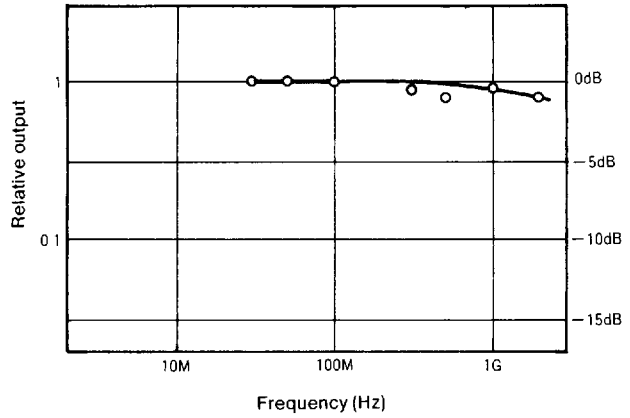
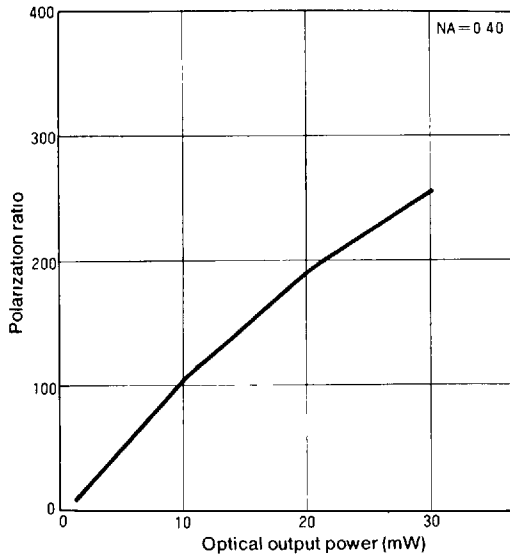

Fig. 94-3 Polarization Ratio vs. Optical Power Output (LT024 series, LT015 series)



Note All data on this page is typical only, and is not intended as a specification. The shapes of these curves can be used as a general reference, but the actual characteristics will vary from device to device.

Built-in PIN Photodiode Characteristics

Fig. 95-1 Photodiode Frequency Response Characteristic

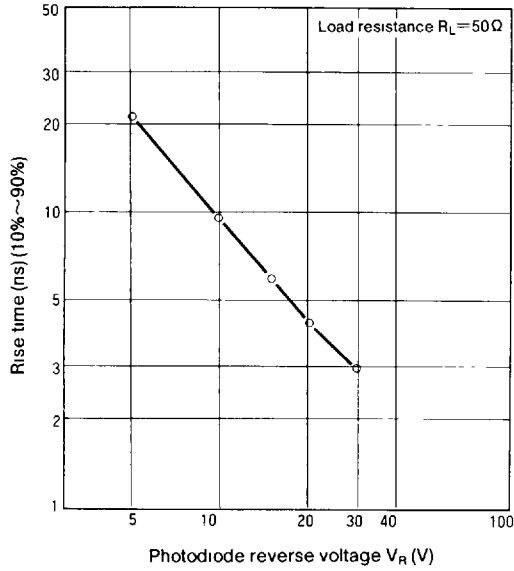
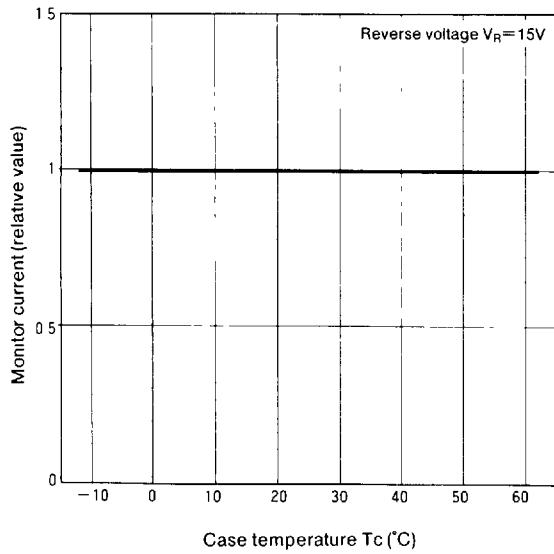

Fig. 95-2 Photodiode Temperature Characteristic



Note: All data on this page is typical only, and is not intended as a specification. The shapes of these curves can be used as a general reference, but the actual characteristics will vary from device to device.

Outline Dimensions

Unit: mm

Fig. 98-1 Standard Type (C Type)

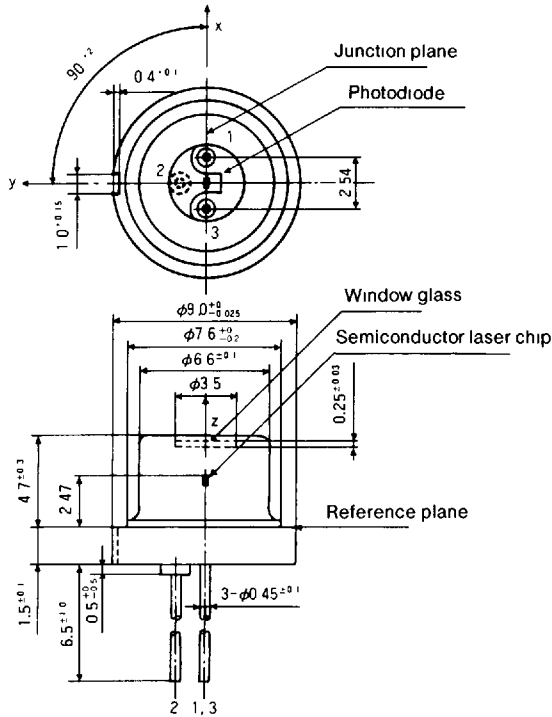

Fig. 98-2 Low-Cap Type (D Type)

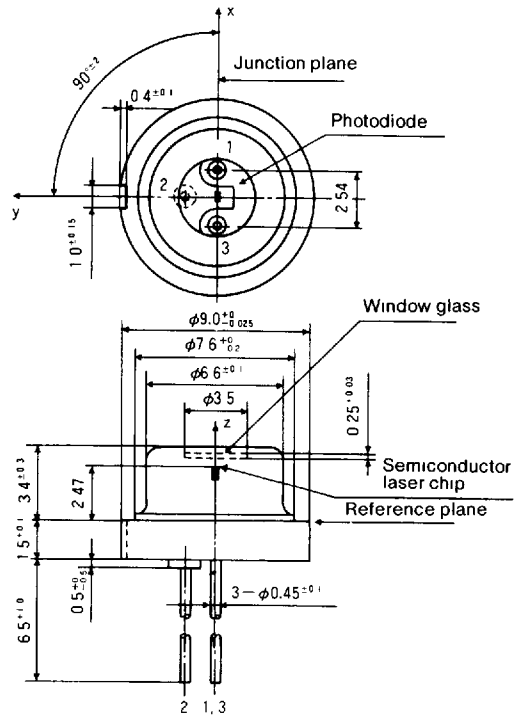

Fig. 98-3 Fin-Equipped Type (F Type)

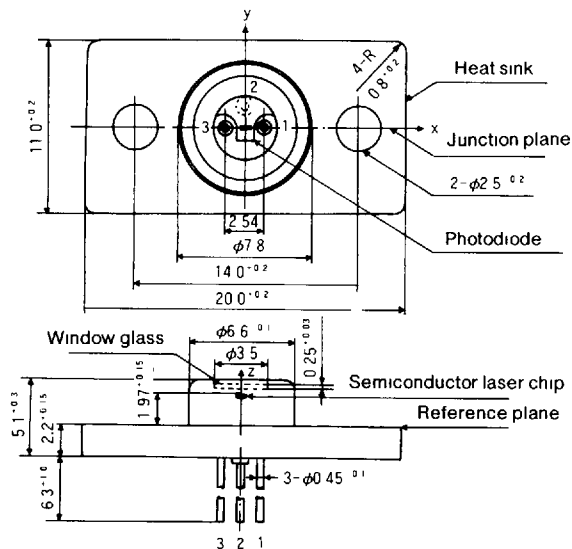
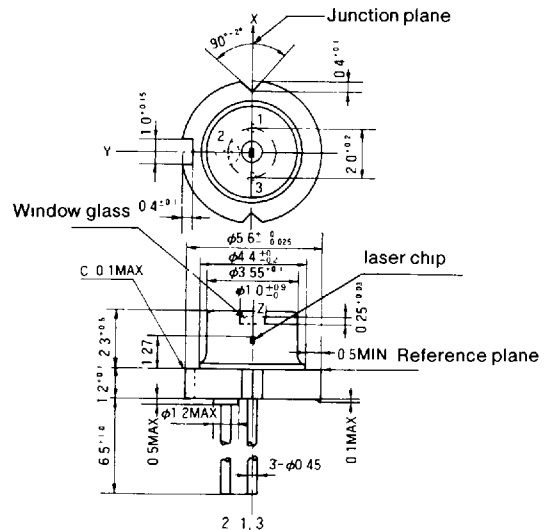

Fig. 98-4 Compact Package Type (S Type)



Terminal connections

