

# PC928 Series

## Built-in Short Protection Circuit, Gate Drive SMD 14 pin \*OPIC Photocoupler

勝特力電材超市-龍山店 886-3-5773766  
 勝特力電材超市-光復店 886-3-5729570  
 勝特力電子(上海) 86-21-34970699  
 勝特力電子(深圳) 86-755-83298787  
<http://www.100y.com.tw>

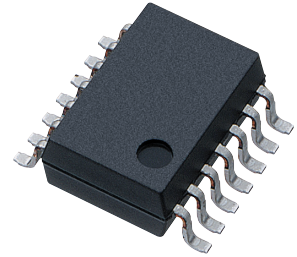

### ■ Description

**PC928 Series** contains an IRED optically coupled to an OPIC chip.

It is packaged in a Mini-flat, Half pitch type (14 pin).  
 Input-output isolation voltage(rms) is 4.0kV.

### ■ Features

1. 14 pin Half lead pin pitch (Lead pitch=1.27 mm) package type
2. Double transfer mold package  
(Ideal for Flow Soldering)
3. Built-in IGBT shortcircuit protector circuit
4. Built-in direct drive circuit for IGBT drive  
(Peak output current :  $I_{O1P}$ ,  $I_{O2P}$  : MAX. 0.4 A)
5. High isolation voltage ( $V_{iso(rms)}$  : 4.0 kV)

### ■ Agency approvals/Compliance

1. Recognized by UL1577, file No. E64380 (as model No. **PC928**)
2. Approved by VDE (VDE0884) (as an option) file No. 94626 (as model No. **PC928**)
3. Package resin : UL flammability grade (94V-0)

### ■ Applications

1. Inverter

\* "OPIC"(Optical IC) is a trademark of the SHARP Corporation. An OPIC consists of a light-detecting element and a signal-processing circuit integrated onto a single chip.

Notice The content of data sheet is subject to change without prior notice.

In the absence of confirmation by device specification sheets, SHARP takes no responsibility for any defects that may occur in equipment using any SHARP devices shown in catalogs, data books, etc. Contact SHARP in order to obtain the latest device specification sheets before using any SHARP device.

## Internal Connection Diagram

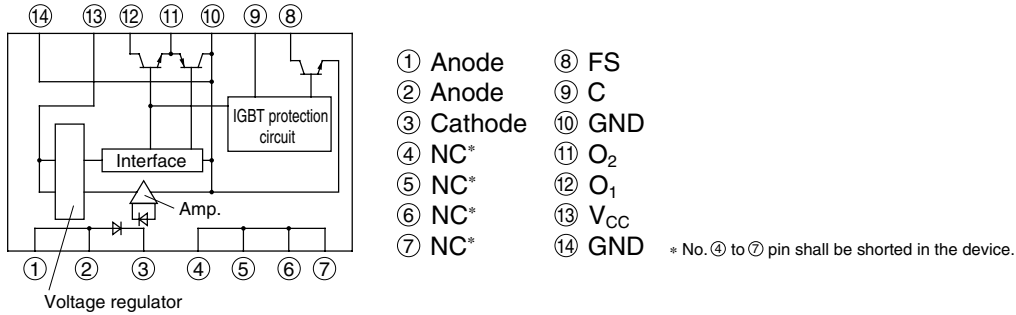

## Truth table

Input	C input-output	O <sub>2</sub> output	FS output	
ON	Low level	High level	High level	
	High level	Low level	Low level	At operating protection function
OFF	Low level	Low level	High level	
	High level	Low level	High level	

## Outline Dimensions

(Unit : mm)

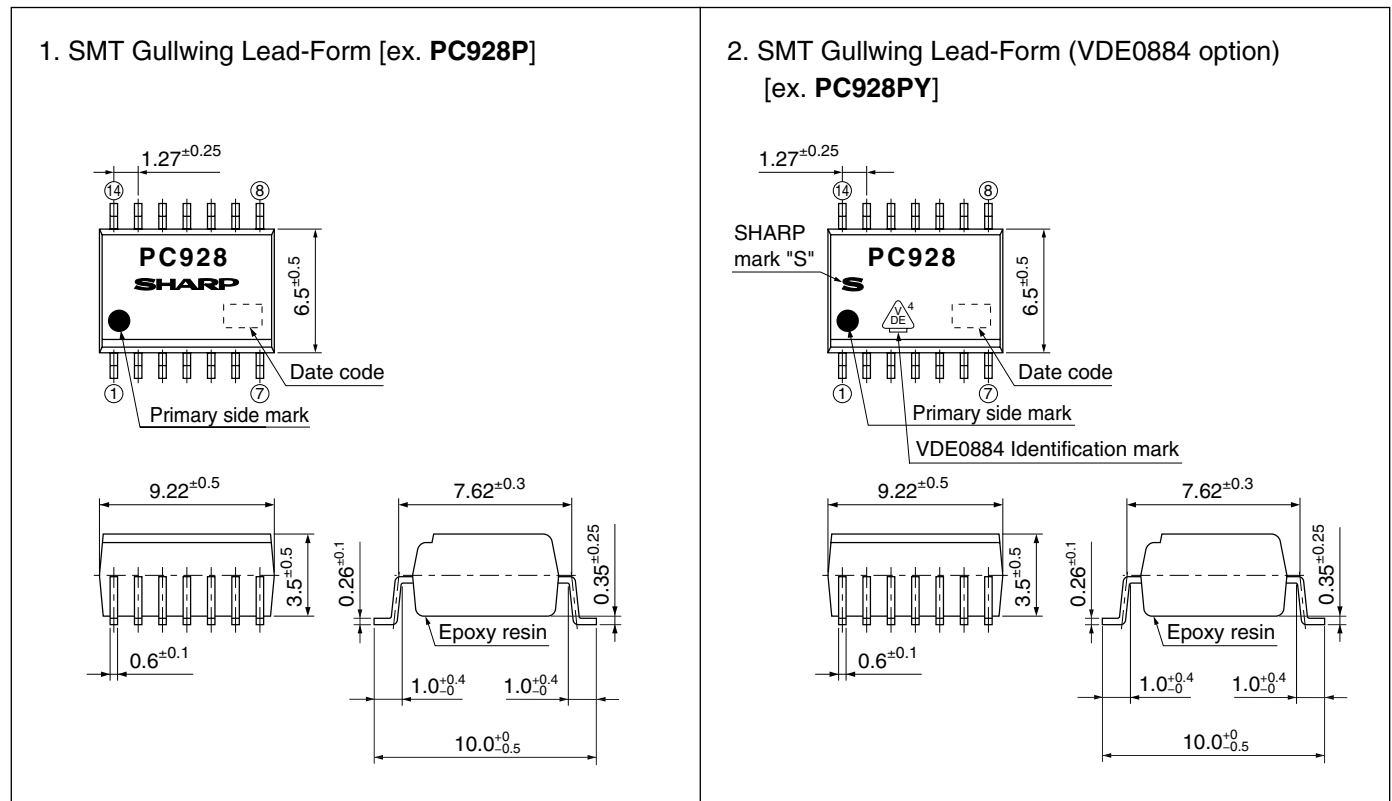

Product mass : approx. 0.47g

Date code (2 digit)

1st digit				2nd digit	
Year of production				Month of production	
A.D.	Mark	A.D	Mark	Month	Mark
1990	A	2002	P	January	1
1991	B	2003	R	February	2
1992	C	2004	S	March	3
1993	D	2005	T	April	4
1994	E	2006	U	May	5
1995	F	2007	V	June	6
1996	H	2008	W	July	7
1997	J	2009	X	August	8
1998	K	2010	A	September	9
1999	L	2011	B	October	O
2000	M	2012	C	November	N
2001	N	∴	∴	December	D

repeats in a 20 year cycle

Country of origin  
Japan

**■ Absolute Maximum Ratings**

(unless otherwise specified  $T_a=T_{opr}$ )

	Parameter	Symbol	Rating	Unit
Input	*1 Forward current	$I_F$	25	mA
	*2 Reverse voltage	$V_R$	6	V
Output	Supply voltage	$V_{CC}$	35	V
	O <sub>1</sub> output current	$I_{O1}$	0.1	A
	*3 O <sub>1</sub> peak output current	$I_{O1P}$	0.4	A
	O <sub>2</sub> output current	$I_{O2}$	0.1	A
	*3 O <sub>2</sub> peak output current	$I_{O2P}$	0.4	A
	O <sub>1</sub> output voltage	$V_{O1}$	35	V
	*4 Power dissipation	$P_O$	500	mW
	Overcurrent detection voltage	$V_C$	$V_{CC}$	V
	Overcurrent detection current	$I_C$	30	mA
	Error signal output voltage	$V_{FS}$	$V_{CC}$	V
	Error signal output current	$I_{FS}$	20	mA
*5 Total power dissipation	$P_{tot}$	550	mW	
*6 Isolation voltage	$V_{iso (rms)}$	4.0	kV	
Operating temperature	$T_{opr}$	-25 to +80	°C	
Storage temperature	$T_{stg}$	-55 to +125	°C	
*7 Soldering temperature	$T_{sol}$	260	°C	

\*1 The derating factors of a absolute maximum ratings due to ambient temperature are shown in Fig.15

\*2  $T_a=25^{\circ}C$

\*3 Pulse width $\leq 0.15\mu s$ , Duty ratio : 0.01

\*4.5 The derating factors of a absolute maximum ratings due to ambient temperature are shown in Fig.16

\*6 AC for 1 minute, 40 to 60%RH,  $T_a=25^{\circ}C$ ,  $f=60Hz$

\*7 For 10s

**■ Electro-optical Characteristics**

(unless otherwise specified  $T_a=T_{opr}$ )

	Parameter	Symbol	Conditions *8	MIN.	TYP.	MAX.	Unit
Input	Forward voltage	$V_{F1}$	$T_a=25^{\circ}C, I_F=20mA$	-	1.2	1.4	V
		$V_{F2}$	$T_a=25^{\circ}C, I_F=0.2mA$	0.6	0.9	-	V
	Reverse current	$I_R$	$T_a=25^{\circ}C, V_R=4V$	-	-	10	$\mu A$
	Terminal capacitance	$C_t$	$T_a=25^{\circ}C, V=0, f=1kHz$	-	30	250	pF
Output	Supply voltage	$V_{CC}$	$T_a=-10$ to $+60^{\circ}C$	15	-	30	V
			-	15	-	24	V
	O <sub>1</sub> Low level output voltage	$V_{O1L}$	$V_{CC1}=12V, V_{CC2}=-12V, I_{O1}=0.1A, I_F=10mA$ *9	-	0.2	0.4	V
	O <sub>2</sub> High level output voltage	$V_{O2H}$	$V_{CC}=V_{O1}=24V, I_{O2}=-0.1A, I_F=10mA$ *9	20	22	-	V
	O <sub>2</sub> Low level output voltage	$V_{O2L}$	$V_{CC}=24V, I_{O2}=0.1A, I_F=0$ *9	-	1.2	2.0	V
	O <sub>1</sub> leak current	$I_{O1L}$	$T_a=25^{\circ}C, V_{CC}=V_{O1}=35V, I_F=0$ *9	-	-	500	$\mu A$
	High level supply current	$I_{CCH}$	$T_a=25^{\circ}C, V_{CC}=24V, I_F=10mA$ *9	-	10	17	mA
			$V_{CC}=V_{O1}=24V, I_F=10mA$ *9	-	-	19	mA
Low level supply current	$I_{CCL}$	$T_a=25^{\circ}C, V_{CC}=V_{O1}=24V, I_F=0$ *9	-	11	18	mA	
		$V_{CC}=V_{O1}=24V, I_F=0$ *9	-	-	20	mA	

\*8 It shall connect a by-pass capacitor of 0.01  $\mu F$  or more between  $V_{CC}$  (pin ③) and GND (pin, ⑩, ④) near the device, when it measures the transfer characteristics and the output side characteristics.

\*9 FS=OPEN,  $V_C=0$

(unless otherwise specified  $T_a=T_{opr}$ )

Parameter		Symbol	Conditions *10	MIN.	TYP.	MAX.	Unit	
Transfer characteristics	*11 "Low→High" input threshold current	$I_{FLH}$	$T_a=25^\circ\text{C}$ , $V_{CC}=V_{O1}=24\text{V}$ , $FS=OPEN$ , $V_C=0$	1.0	4.0	7.0	mA	
			$V_{CC}=V_{O1}=24\text{V}$ , $FS=OPEN$ , $V_C=0$	0.6	-	10	mA	
	Isolation resistance	$R_{ISO}$	$T_a=25^\circ\text{C}$ , $DC=500\text{V}$ , 40 to 60%RH	$5 \times 10^{10}$	$10^{11}$	-	$\Omega$	
	Response time	"Low→High" propagation delay time	$t_{PLH}$	$T_a=25^\circ\text{C}$ , $V_{CC}=V_{O1}=24\text{V}$ , $I_F=10\text{mA}$ , $R_G=47\Omega$ , $C_G=3\ 000\text{pF}$ $FS=OPEN$ , $V_C=0$	-	1.0	2.0	$\mu\text{s}$
		"High→Low" propagation delay time	$t_{PHL}$		-	1.0	2.0	$\mu\text{s}$
		Rise time	$t_r$		-	0.2	0.5	$\mu\text{s}$
		Fall time	$t_f$		-	0.2	0.5	$\mu\text{s}$
	Instantaneous common mode rejection voltage (High level output)	$CM_H$	$T_a=25^\circ\text{C}$ , $V_{CM}=600\text{V(p-p)}$ $I_F=10\text{mA}$ , $V_{CC}=V_{O1}=24\text{V}$ , $\Delta V_{O2H}=2.0\text{V}$ , $FS=OPEN$ , $V_C=0$	-1.5	-	-	kV/ $\mu\text{s}$	
	Instantaneous common mode rejection voltage (Low level output)	$CM_L$	$T_a=25^\circ\text{C}$ , $V_{CM}=600\text{V(p-p)}$ $I_F=0$ , $V_{CC}=V_{O1}=24\text{V}$ , $\Delta V_{O2L}=2.0\text{V}$ , $FS=OPEN$ , $V_C=0$	1.5	-	-	kV/ $\mu\text{s}$	
	Overcurrent detection	*12 Overcurrent detection voltage	$V_{CTH}$	$T_a=25^\circ\text{C}$ $V_{CC}=V_{O1}=24\text{V}$ $I_F=10\text{mA}$ , $R_G=47\Omega$ $C_G=3\ 000\text{pF}$ , $FS=OPEN$	$V_{CC}-6.5$	$V_{CC}-6$	$V_{CC}-5.5$	V
Overcurrent detection voltage hysteresis width		$V_{CHIS}$	1		2	3	V	
Protection output	O <sub>2</sub> "High→Low" propagation delay time at overcurrent protection	$t_{PCOHL}$	$T_a=25^\circ\text{C}$ $V_{CC}=V_{O1}=24\text{V}$ $I_F=10\text{mA}$ , $R_G=47\Omega$ , $C_G=3\ 000\text{pF}$ , $R_C=1\text{k}\Omega$ , $C_P=1\ 000\text{pF}$ $FS=OPEN$	-	4	10	$\mu\text{s}$	
	O <sub>2</sub> Fall time at overcurrent protection	$t_{PCOf}$		2	5	-	$\mu\text{s}$	
	O <sub>2</sub> "High→Low" output voltage at overcurrent protection	$V_{OE}$		-	-	2	V	
Error signal output	Low level error signal voltage	$V_{FSL}$	$T_a=25^\circ\text{C}$ , $I_F=10\text{mA}$ $V_{CC}=V_{O1}=24\text{V}$ $I_{FS}=10\text{mA}$ , $R_G=47\Omega$ $C_G=3\ 000\text{pF}$ , $C=OPEN$	-	0.2	0.4	V	
	High level error signal current	$I_{FSH}$		-	-	100	$\mu\text{A}$	
	Error signal "High→Low" propagation delay time	$t_{PCFHL}$		$T_a=25^\circ\text{C}$ , $V_{CC}=V_{O1}=24\text{V}$ $I_F=10\text{mA}$ , $R_{FS}=1.8\text{k}\Omega$ $R_G=47\Omega$ , $R_C=1\text{k}\Omega$ $C_G=3\ 000\text{pF}$ , $C_P=1\ 000\text{pF}$	-	1	5	$\mu\text{s}$
	Error signal output pulse width	$\Delta t_{FS}$			20	35	-	$\mu\text{s}$

\*10 It shall connect a by-pass capacitor of 0.01  $\mu\text{F}$  or more between  $V_{CC}$  (pin ⑬) and GND (pin ⑩, ⑭) near the device, when it measures the device, when it measures the overcurrent characteristics, Protection output characteristics, and Error signal output characteristics.

\*11  $I_{FLH}$  represents forward current when output goes from "Low" to "High"

\*12  $V_{CTH}$  is the value of C (pin ⑨) voltage when output becomes from "High" to "Low"

**■ Model Line-up**

Lead Form	SMT Gullwing			
Package	Sleeve		Taping	
	50pcs/sleeve		1 000pcs/reel	
VDE0884	——	Approved	——	Approved
Model No.	<b>PC928</b>	<b>PC928Y</b>	<b>PC928P</b>	<b>PC928PY</b>

Please contact a local SHARP sales representative to inquire about production status and Lead-Free options.

**Fig.1 Test Circuit for O<sub>1</sub> Low Level Output Voltage**

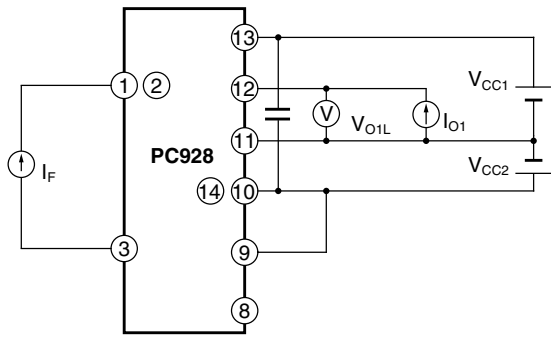

**Fig.2 Test Circuit for O<sub>2</sub> High Level Output Voltage**

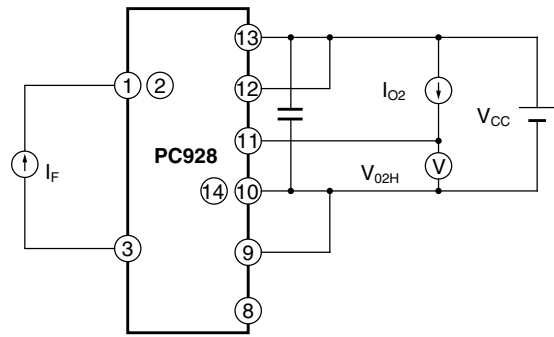

**Fig.3 Test Circuit for O<sub>2</sub> Low Level Output Voltage**

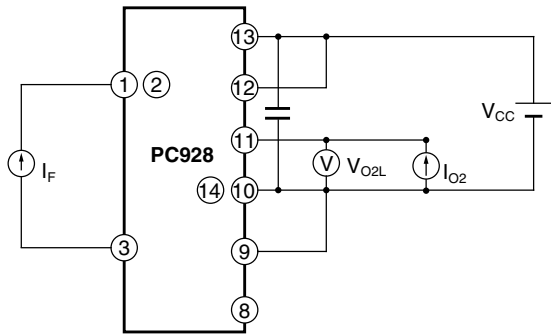

**Fig.4 Test Circuit for O<sub>1</sub> Leak Current**

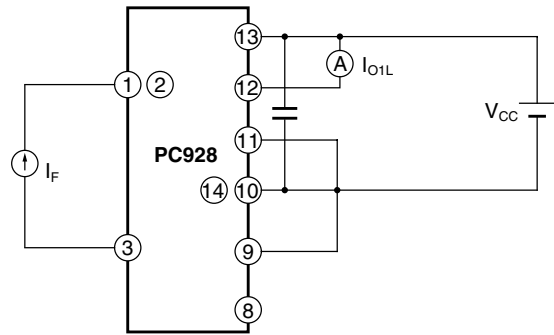

**Fig.5 Test Circuit for "Low→High" Input Threshold Current**

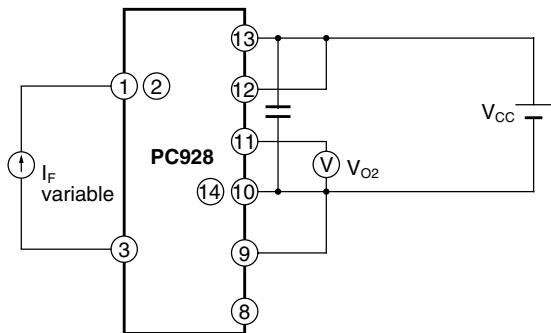

**Fig.6 Test Circuit for High Level / Low Level Supply Current**

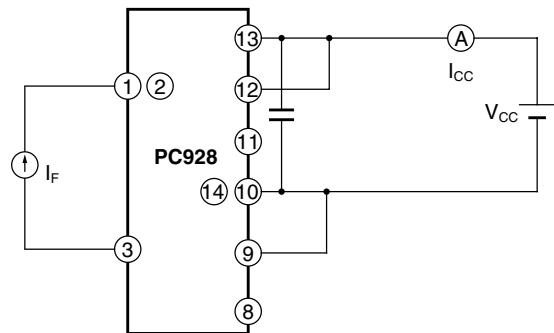

**Fig.7 Test Circuit for Instantaneous Common Mode Rejection Voltage**

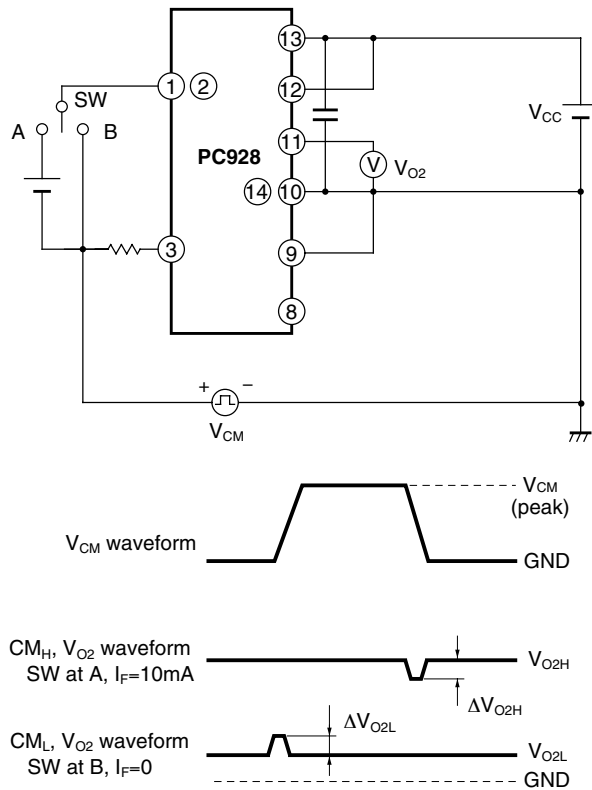

**Fig.8 Test Circuit for Response Time**

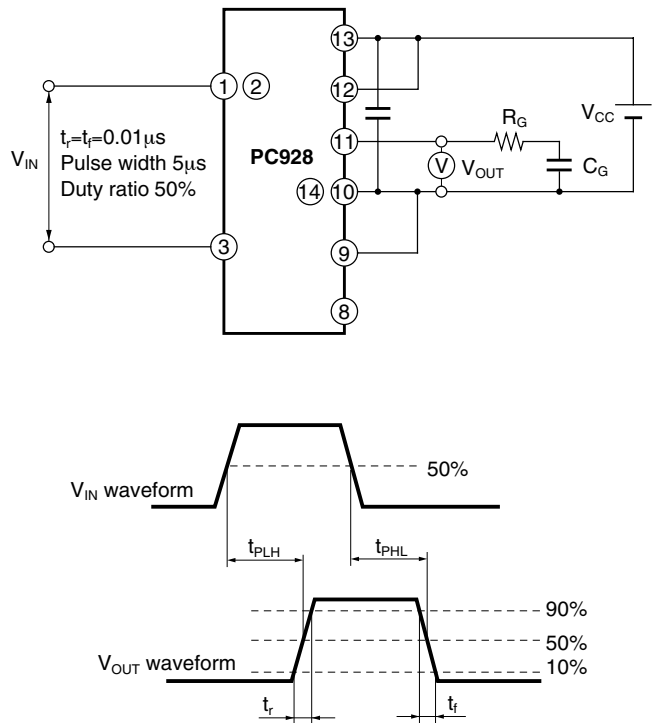

**Fig.9 Test Circuit for Overcurrent Detection Voltage, Overcurrent Detection Voltage Hysteresis**

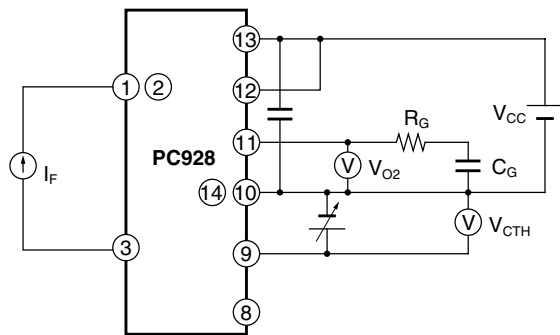

**Fig.10 Test Circuit for O<sub>2</sub> Output Voltage at Overcurrent Protection**

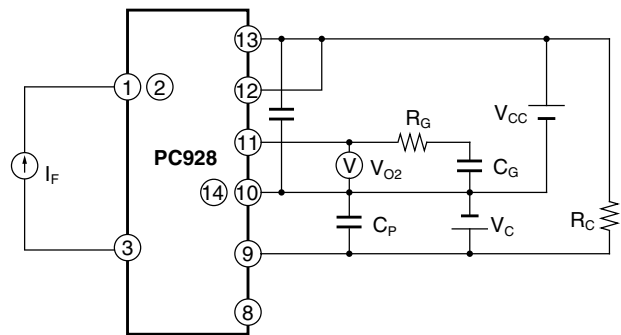

**Fig.11 Test Circuit for O<sub>1</sub> Low Level Error Signal Voltage**

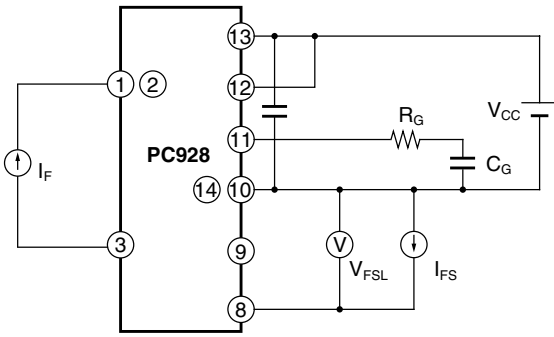

**Fig.12 Test Circuit for High Level Error Signal Current**

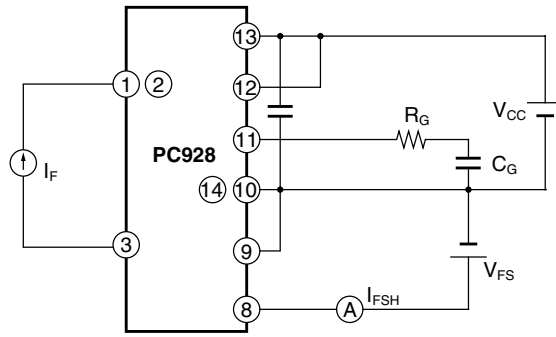

**Fig.13 Test Circuit for O<sub>2</sub> "High→Low" Propagation Delay Time at Overcurrent Protection, O<sub>2</sub> Fall Time at Overcurrent Protection**

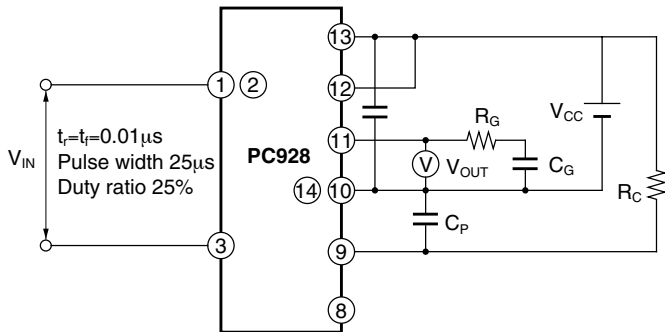

**Fig.14 Error Signal "High→Low" propagation Delay Time, Error Signal Output Pulse Width**

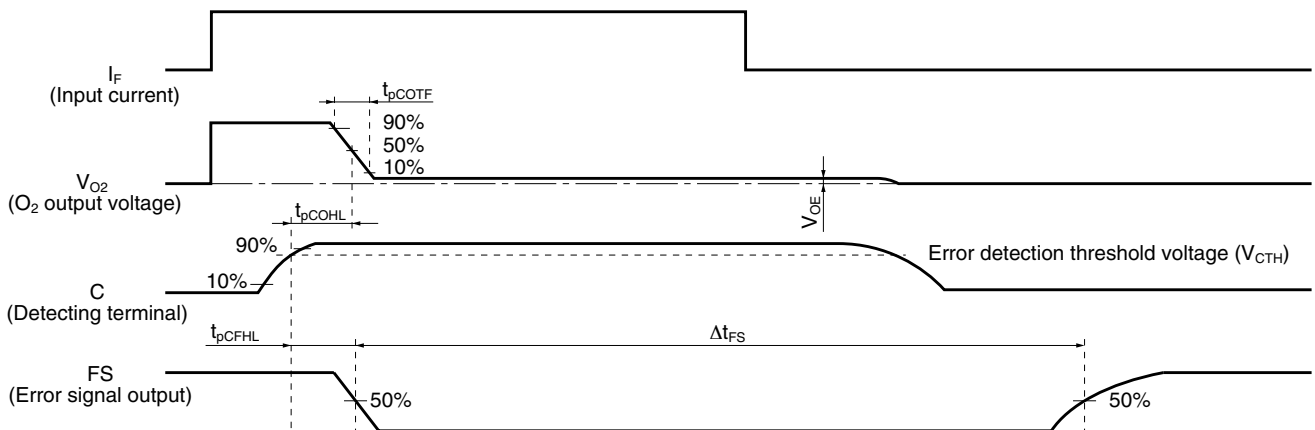
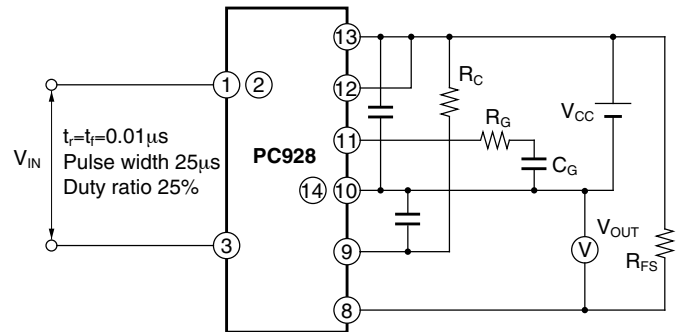

**Fig.15 Forward Current vs. Ambient Temperature**

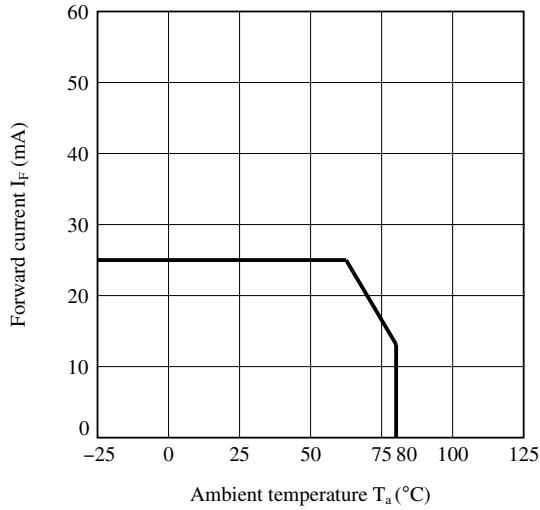

**Fig.16 Power Dissipation vs. Ambient Temperature**

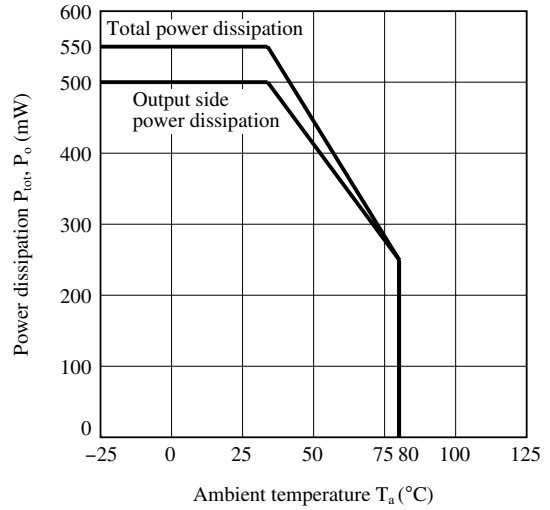

**Fig.17 Forward Current vs. Forward Voltage**

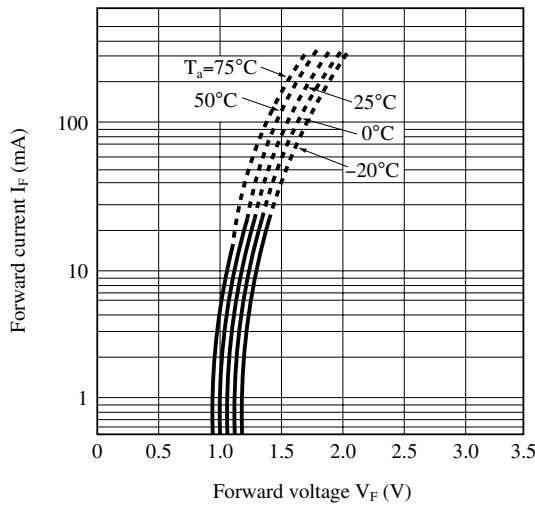

**Fig.18 "Low→High" Relative Input Threshold Current vs. Supply Voltage**

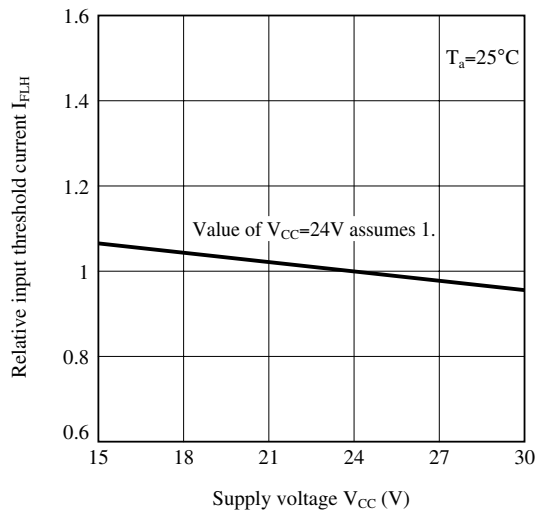

**Fig.19 "Low→High" Relative Input Threshold Current vs. Ambient Temperature**

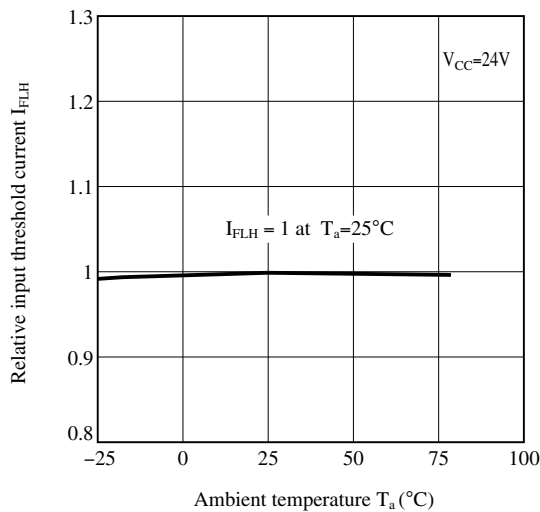

**Fig.20 O<sub>1</sub> Low Level Output Voltage vs. O<sub>1</sub> Output Current**

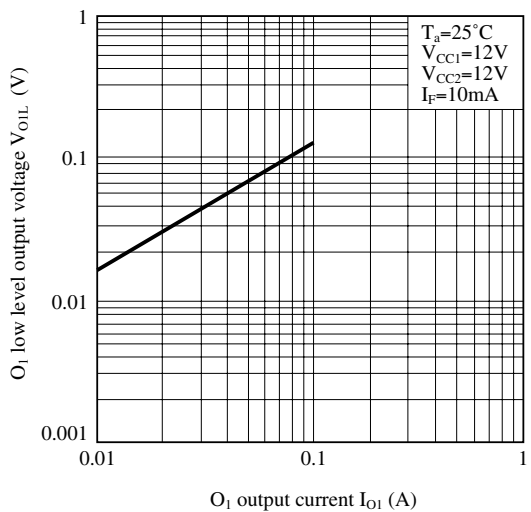

**Fig.21 O<sub>1</sub> Low Level Output Voltage vs. Ambient Temperature**

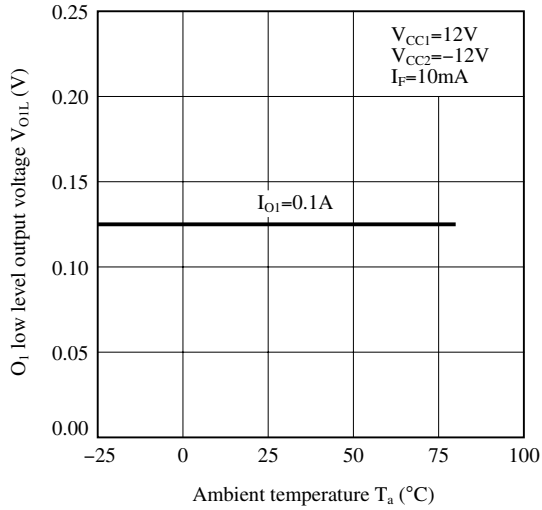

**Fig.22 O<sub>1</sub> Leak Current vs. Ambient Temperature**

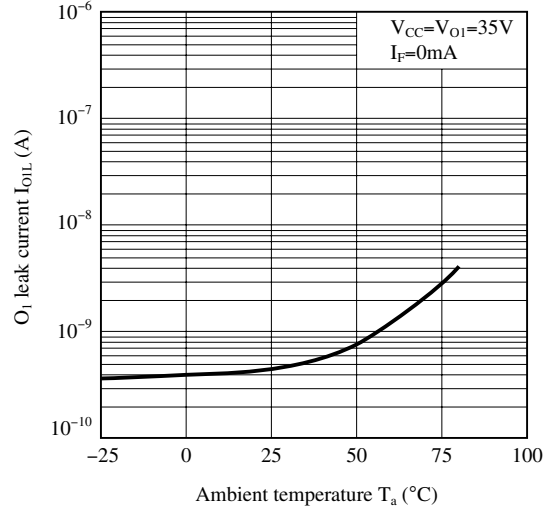

**Fig.23 O<sub>2</sub> High Level Output Voltage vs. Supply Voltage**

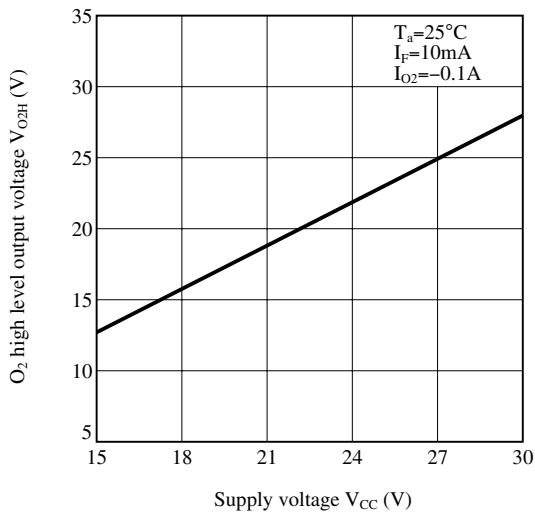

**Fig.24 O<sub>2</sub> High Level Output Voltage vs. Ambient Temperature**

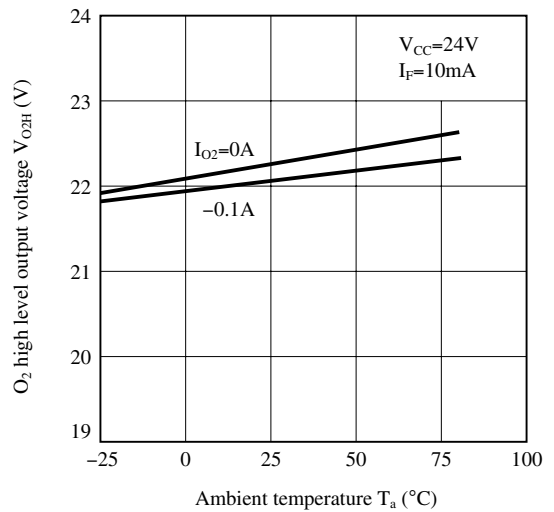

**Fig.25 O<sub>2</sub> Low Level Output Voltage vs. Output Current**

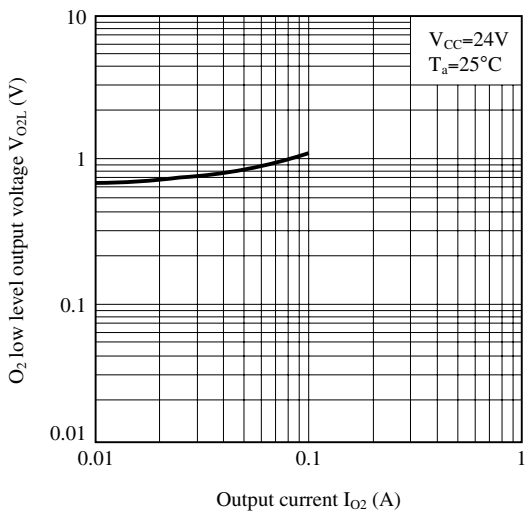

**Fig.26 O<sub>2</sub> Low Level Output Voltage vs. Ambient Temperature**

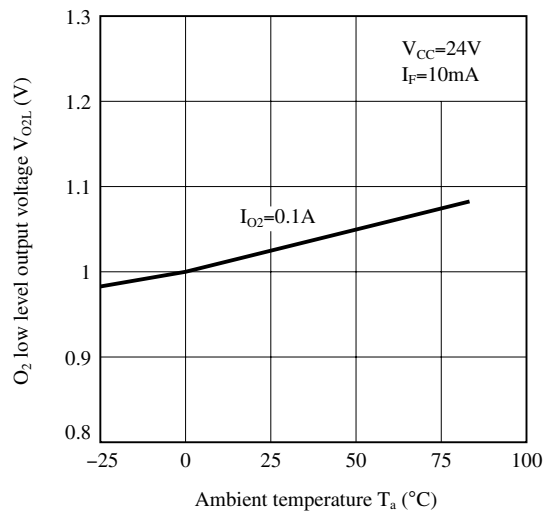

**Fig.27 High Level Supply Current vs. Supply Voltage**

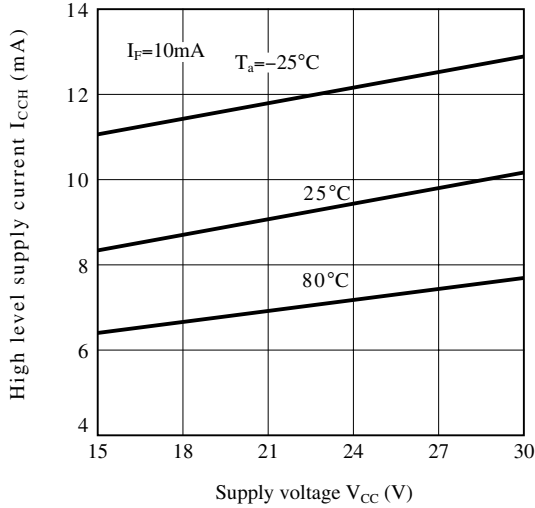

**Fig.28 Low Level Supply Current vs. Supply Voltage**

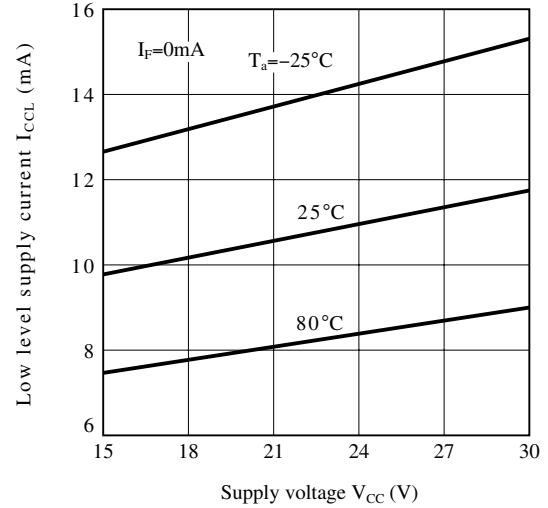

**Fig.29 Propagation Delay Time vs. Forward Current**

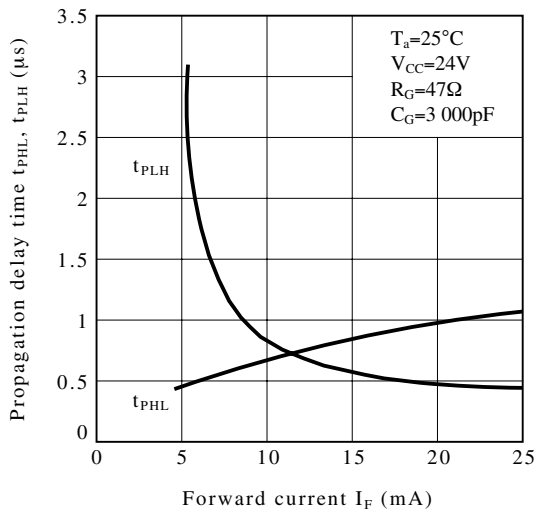

**Fig.30 Propagation Delay Time vs. Ambient Temperature**

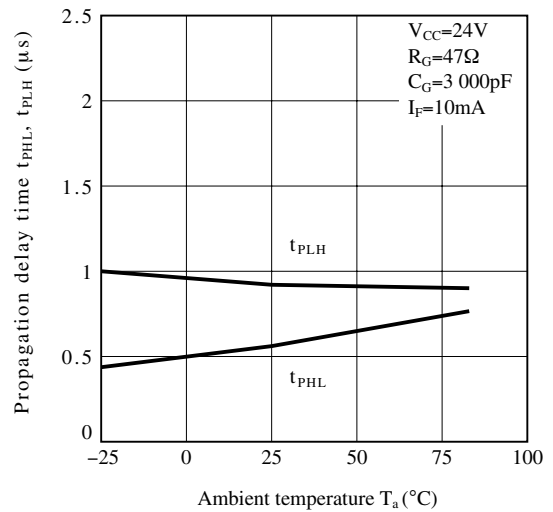

**Fig.31 Overcurrent Detecting Voltage vs. Ambient Temperature**

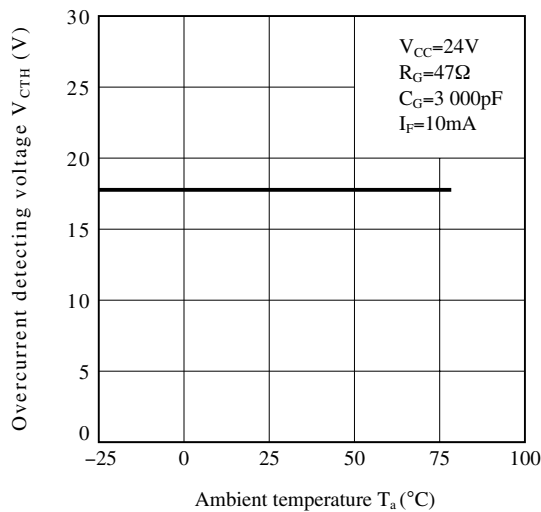

**Fig.32 O<sub>2</sub> Output Fall Time at Protection from Overcurrent/O<sub>2</sub> "High-Low" Propagation Delay Time at Protection from Overcurrent vs. Ambient Temperature**

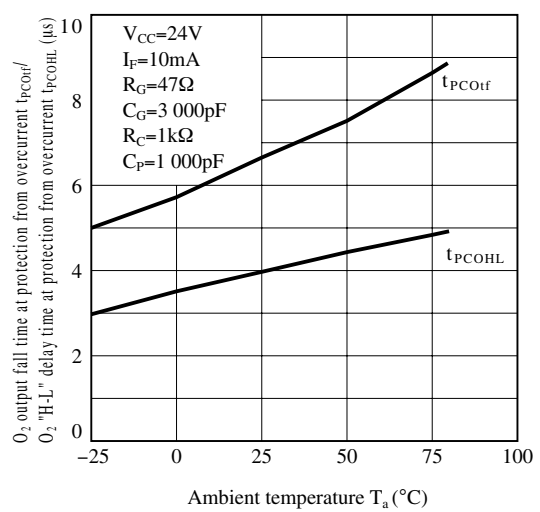

**Fig.33 Error Signal "High-Low" Propagation Delay Time vs. Ambient Temperature**

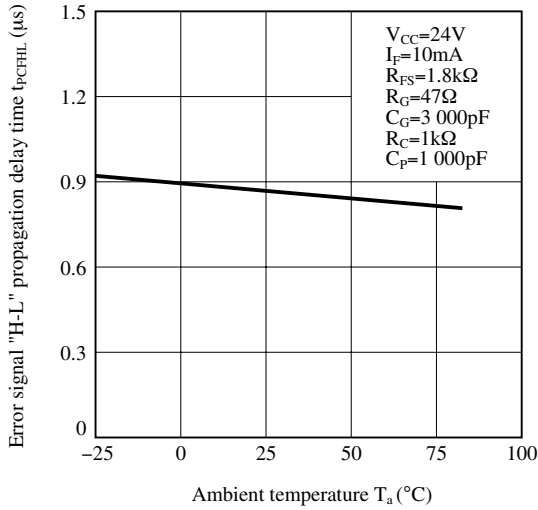

**Fig.34 O<sub>2</sub> Output Voltage at Protection from Overcurrent vs. Ambient Temperature**

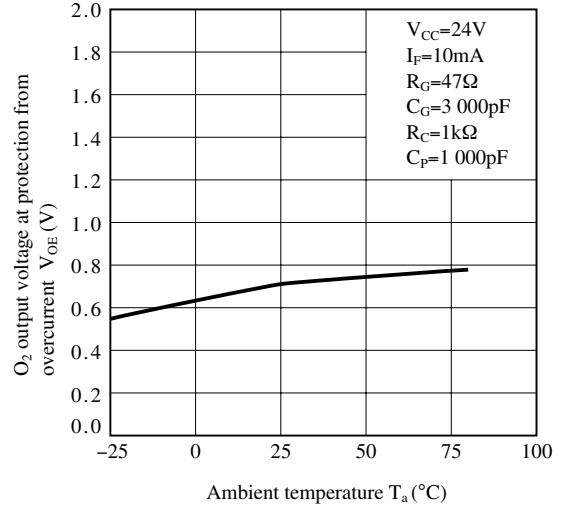

**Fig.35 Low Level Error Signal Voltage vs. Ambient Temperature**

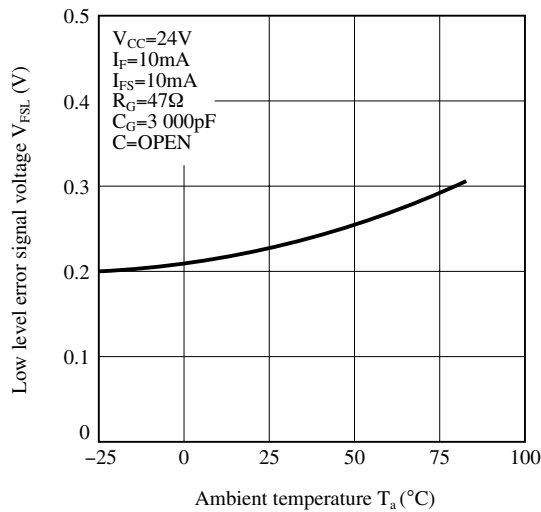

**Fig.36 High Level Error Signal Current vs. Ambient Temperature**

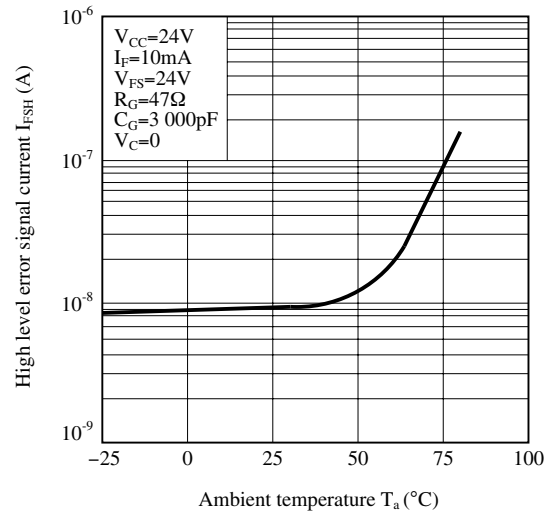

**Fig.37 Error Signal Output Pulse Width vs. Ambient Temperature**

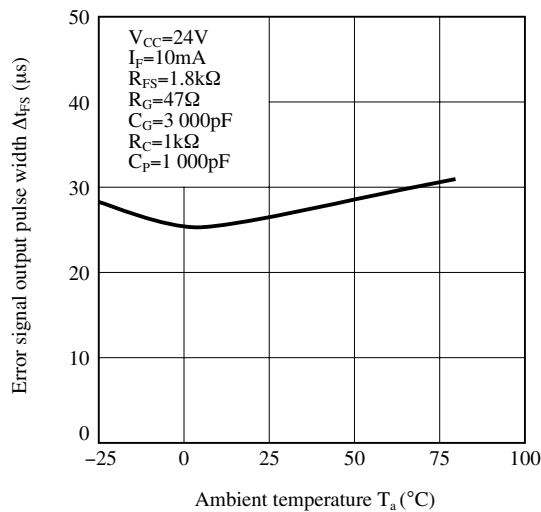

**Fig.38 Overcurrent Detecting Voltage vs. Supply Voltage**

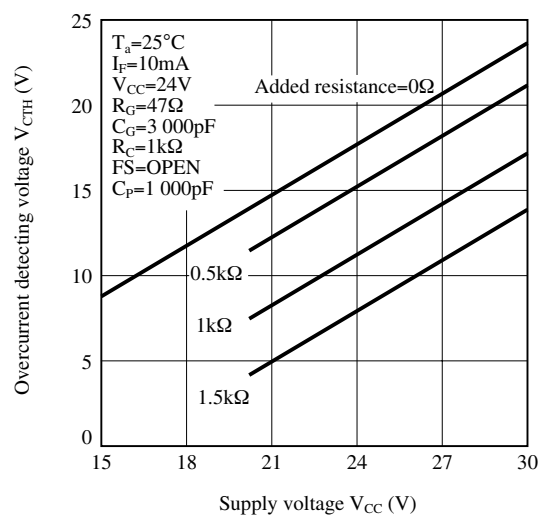

Fig.39 Overcurrent Detecting Voltage - Supply Voltage Characteristics Test Circuit

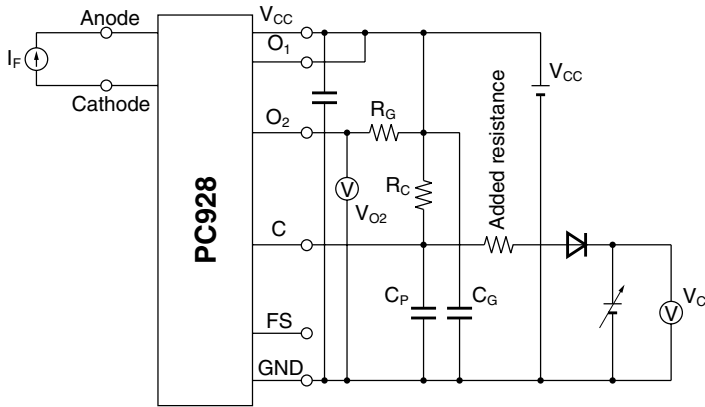
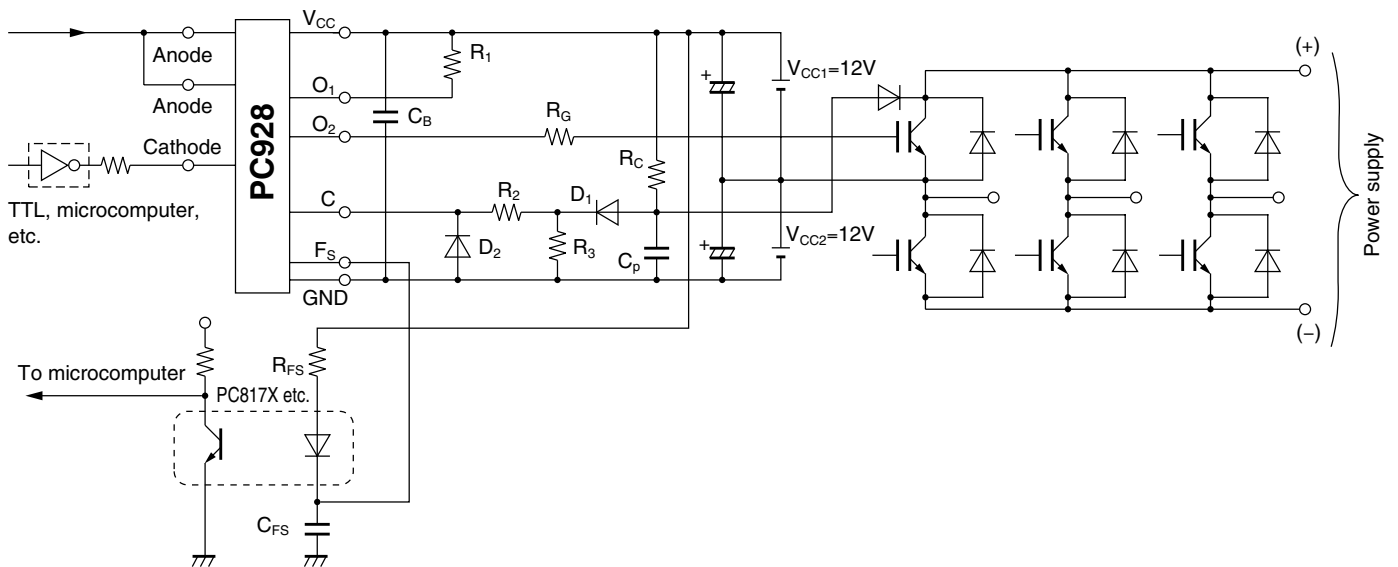

Fig.40 Example of The Application Circuit (IGBT Drive for Inverter)



- In order to stabilize the power supply line, we recommend to locate a bypass capacitor  $C_B$  ( $0.01\mu\text{F}$  or more) between  $V_{CC}$  and GND near photocoupler.
- In order to stabilize the detecting voltage of pin-C, we recommend to locate a capacitor  $C_P$  (approximately  $1\ 000\text{pF}$ ) between pin-C and GND, and a resistor  $R_C$  (approximately  $1.0\text{k}\Omega$ ) between  $V_{CC}$  and pin-C. However, the rise time of the detection voltage at Pin-C varies along with the time constants of  $C_P$  and  $R_C$ . So, please make sure the device works properly in actual conditions.
- For the diode D, which is located between pin-C and collector of IGBT, we recommend to use a diode that has the withstand voltage characteristic equivalent to IGBT and also has little leak current.
- In order to prevent the failure mode or breakdown of pin-C from  $V_{CE}$  variation of IGBT, we recommend to locate a resistor  $R_2$  (approximately  $10\text{k}\Omega$ ) and a diode D1 at near pin-C, and a resistor  $R_3$  (approximately  $50\text{k}\Omega$ ) and a diode D2 at between pin-C and GND.

This application circuit shows the general example of a circuit, and is not a design guarantee for right operation.

**Fig.41 Operations of Shortcircuit Protector Circuit**

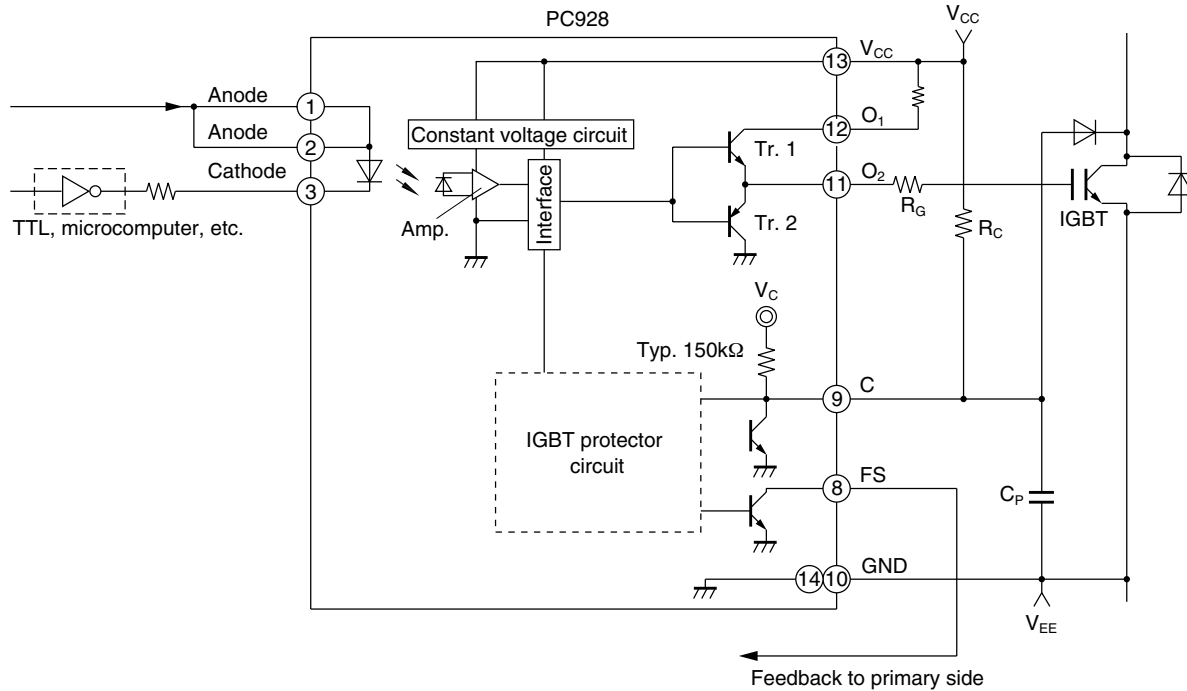

1. Detection of increase in  $V_{CE(sat)}$  of IGBT due to overcurrent by means of C terminal (pin ⑨)
2. Reduction of the IGBT gate voltage, and suppression of the collector current
3. Simultaneous output of signals to indicate the shortcircuit condition (FS signal) from FS terminal (pin ⑧) to the microcomputer
4. Judgement and processing by the microcomputer
  - In the case of instantaneous shortcircuit, run continues.
  - At fault, input to the photocoupler is cut off, and IGBT is turned OFF.

Remarks : Please be aware that all data in the graph are just for reference and not for guarantee.

**■ Design Considerations****● Notes about static electricity**

Transistor of detector side in bipolar configuration may be damaged by static electricity due to its minute design.

When handling these devices, general countermeasure against static electricity should be taken to avoid breakdown of devices or degradation of characteristics.

**● Design guide**

In order to stabilize power supply line, we should certainly recommend to connect a by-pass capacitor of 0.01 $\mu$ F or more between  $V_{CC}$  and GND near the device.

We recommend to use approximately 1 000pF of capacitor between C-pin and GND in order to prevent miss operation by noise.

In the case that capacitor is used approximately 1k $\Omega$  of resistance shall be recommended to use between  $V_{CC}$  and C-pin However, the rise time of C-pin shall be changed by time constant of added CR, so that please use this device after confirmation.

In case that some sudden big noise caused by voltage variation is provided between primary and secondary terminals of photocoupler some current caused by it is floating capacitance may be generated and result in false operation since current may go through IRED or current may change.

If the photocoupler may be used under the circumstances where noise will be generated we recommend to use the bypass capacitors at the both ends of IRED.

The detector which is used in this device, has parasitic diode between each pins and GND.

There are cases that miss operation or destruction possibly may be occurred if electric potential of any pin becomes below GND level even for instant.

Therefore it shall be recommended to design the circuit that electric potential of any pin does not become below GND level.

This product is not designed against irradiation and incorporates non-coherent IRED.

● **Degradation**

In general, the emission of the IRED used in photocouplers will degrade over time.

In the case of long term operation, please take the general IRED degradation (50% degradation over 5years) into the design consideration.

Please decide the input current which become 2times of MAX.  $I_{FLH}$ .

● **Recommended Foot Print (reference)**

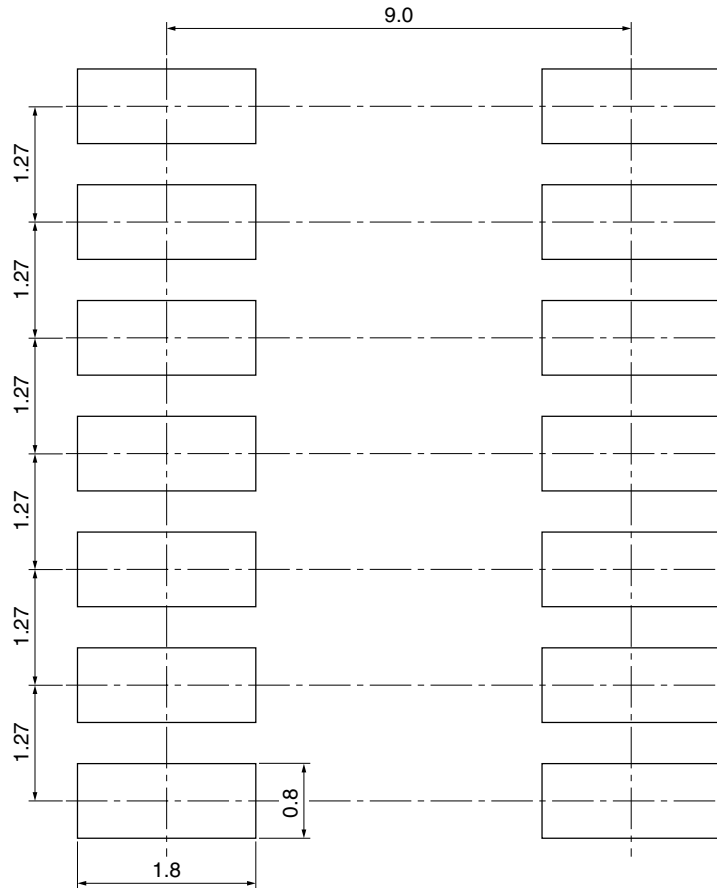

(Unit : mm)

☆ For additional design assistance, please review our corresponding Optoelectronic Application Notes.

## ■ Manufacturing Guidelines

### ● Soldering Method

#### Reflow Soldering:

Reflow soldering should follow the temperature profile shown below.  
Soldering should not exceed the curve of temperature profile and time.  
Please don't solder more than twice.

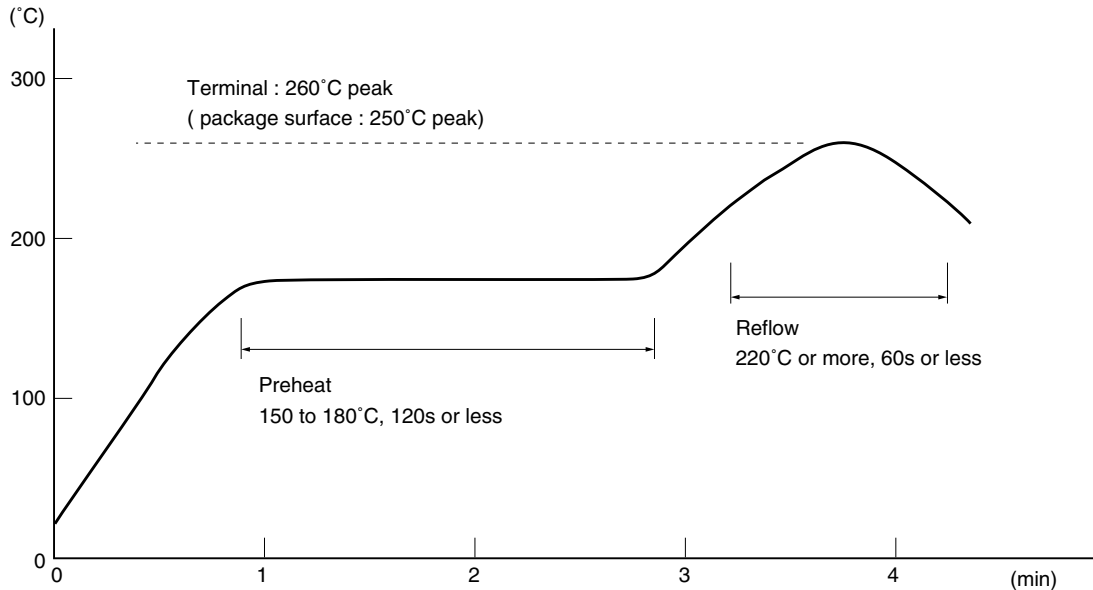

#### Flow Soldering :

Due to SHARP's double transfer mold construction submersion in flow solder bath is allowed under the below listed guidelines.

Flow soldering should be completed below 260°C and within 10s.  
Preheating is within the bounds of 100 to 150°C and 30 to 80s.  
Please don't solder more than twice.

#### Hand soldering

Hand soldering should be completed within 3s when the point of solder iron is below 400°C.  
Please don't solder more than twice.

#### Other notices

Please test the soldering method in actual condition and make sure the soldering works fine, since the impact on the junction between the device and PCB varies depending on the tooling and soldering conditions.

**● Cleaning instructions****Solvent cleaning:**

Solvent temperature should be 45°C or below Immersion time should be 3minutes or less

**Ultrasonic cleaning:**

The impact on the device varies depending on the size of the cleaning bath, ultrasonic output, cleaning time, size of PCB and mounting method of the device.

Therefore, please make sure the device withstands the ultrasonic cleaning in actual conditions in advance of mass production.

**Recommended solvent materials:**

Ethyl alcohol, Methyl alcohol and Isopropyl alcohol

In case the other type of solvent materials are intended to be used, please make sure they work fine in actual using conditions since some materials may erode the packaging resin.

**● Presence of ODC**

This product shall not contain the following materials.

And they are not used in the production process for this device.

Regulation substances : CFCs, Halon, Carbon tetrachloride, 1.1.1-Trichloroethane (Methylchloroform)

Specific brominated flame retardants such as the PBBOs and PBBs are not used in this product at all.

**■ Package specification****● Sleeve package**

## Package materials

Sleeve : HIPS (with anti-static material)

Stopper : Styrene-Elastomer

## Package method

MAX. 50 pcs. of products shall be packaged in a sleeve.

Both ends shall be closed by tabbed and tabless stoppers.

The product shall be arranged in the sleeve with its primary side mark on the tabless stopper side.

MAX. 20 sleeves in one case.

## Sleeve outline dimensions

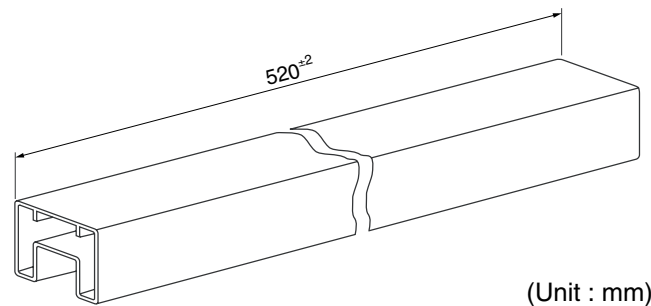
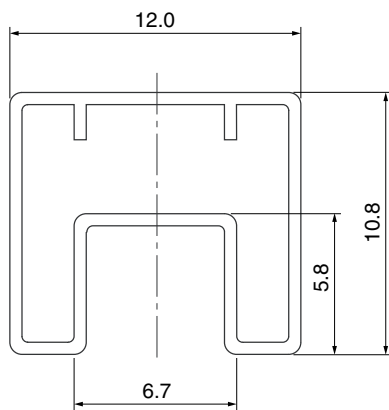

(Unit : mm)

● **Tape and Reel package**

Package materials

Carrier tape : A-PET (with anti-static material)

Cover tape : PET (three layer system)

Reel : PS

Carrier tape structure and Dimensions

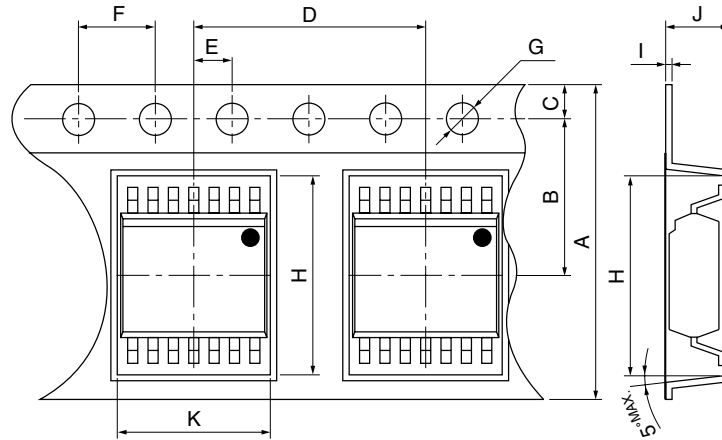

Dimensions List (Unit : mm)

A	B	C	D	E	F	G
16.0±0.3	7.5±0.1	1.75±0.1	12.0±0.1	2.0±0.1	4.0±0.1	φ1.5 <sub>-0</sub> <sup>+0.1</sup>
H	I	J	K			
10.4±0.1	0.4±0.05	4.2±0.1	9.7±0.1			

Reel structure and Dimensions

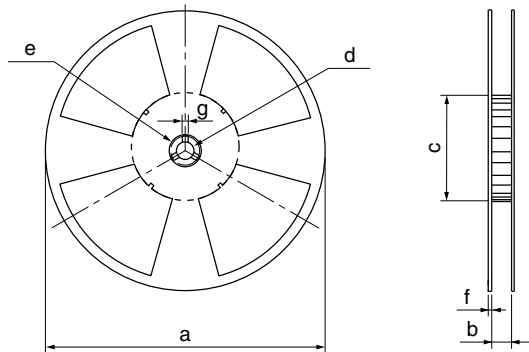

Dimensions List (Unit : mm)

a	b	c	d
330	17.5±1.5	100±1.0	13±0.5
e	f	g	
23±1.0	2.0±0.5	2.0±0.5	

Direction of product insertion

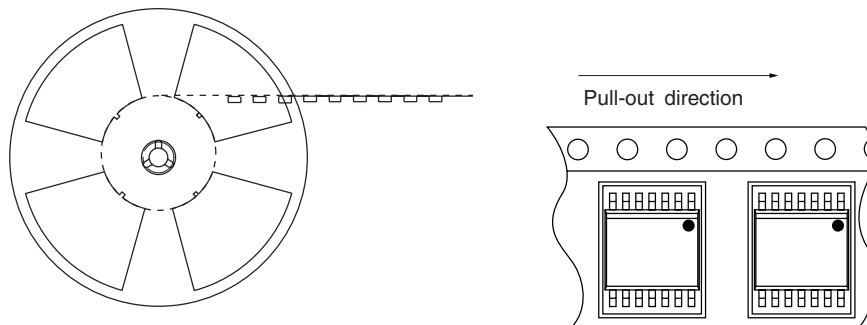

[Packing : 1 000pcs/reel]

## ■ Important Notices

· The circuit application examples in this publication are provided to explain representative applications of SHARP devices and are not intended to guarantee any circuit design or license any intellectual property rights. SHARP takes no responsibility for any problems related to any intellectual property right of a third party resulting from the use of SHARP's devices.

· Contact SHARP in order to obtain the latest device specification sheets before using any SHARP device. SHARP reserves the right to make changes in the specifications, characteristics, data, materials, structure, and other contents described herein at any time without notice in order to improve design or reliability. Manufacturing locations are also subject to change without notice.

· Observe the following points when using any devices in this publication. SHARP takes no responsibility for damage caused by improper use of the devices which does not meet the conditions and absolute maximum ratings to be used specified in the relevant specification sheet nor meet the following conditions:

(i) The devices in this publication are designed for use in general electronic equipment designs such as:

- Personal computers
- Office automation equipment
- Telecommunication equipment [terminal]
- Test and measurement equipment
- Industrial control
- Audio visual equipment
- Consumer electronics

(ii) Measures such as fail-safe function and redundant design should be taken to ensure reliability and safety when SHARP devices are used for or in connection

with equipment that requires higher reliability such as:

- Transportation control and safety equipment (i.e., aircraft, trains, automobiles, etc.)
- Traffic signals
- Gas leakage sensor breakers
- Alarm equipment
- Various safety devices, etc.

(iii) SHARP devices shall not be used for or in connection with equipment that requires an extremely high level of reliability and safety such as:

- Space applications
- Telecommunication equipment [trunk lines]
- Nuclear power control equipment
- Medical and other life support equipment (e.g., scuba).

· If the SHARP devices listed in this publication fall within the scope of strategic products described in the Foreign Exchange and Foreign Trade Law of Japan, it is necessary to obtain approval to export such SHARP devices.

· This publication is the proprietary product of SHARP and is copyrighted, with all rights reserved. Under the copyright laws, no part of this publication may be reproduced or transmitted in any form or by any means, electronic or mechanical, for any purpose, in whole or in part, without the express written permission of SHARP. Express written permission is also required before any use of this publication may be made by a third party.

· Contact and consult with a SHARP representative if there are any questions about the contents of this publication.