

PC923L

High Speed Type Photocoupler for
MOS-FET/IGBT Drive

勝特力材料 886-3-5753170
勝特力电子(上海) 86-21-54151736
勝特力电子(深圳) 86-755-83298787
[Http://www.100y.com.tw](http://www.100y.com.tw)

■ Description

PC923L contains a IRED optically coupled a OPIC.

It is packaged in a 8-pin DIP, available in **SMT gullwing lead-form option.**

Input-output isolation voltage(rms) is 5.0kV.

■ Features

1. Double transfer mold package (ideal for Flow Soldering)
2. Built-in direct drive circuit for MOS-FET/IGBT ($I_{O1P}, I_{O2P} = \text{MAX. } 0.6\text{A}$)
3. High speed response ($t_{PLH}, t_{PHL} : \text{MAX. } 0.5 \mu\text{s}$)
4. Wide operating supply voltage range ($V_{CC} = 15 \text{ to } 35\text{V}$)
5. Low dissipation current ($I_{CC} = \text{TYP. } 1.3\text{mA}$)
6. High noise reduction type ($\text{CMR} = \text{MIN. } 15\text{kV}/\mu\text{s} @ V_{CM} = 1500\text{V}$)
7. High isolation voltage ($V_{iso} = 5\text{kV}$)

■ Agency / Compliance

1. Recognized by UL1577 (Double protection isolation), file No.E64380 (as model No.**PC923L**)
2. Package resion : UL flammability grade (94V-0)

■ Application

1. Inverter controlled refrigerator
2. Inverter controlled air-conditioner
3. General purpose inverter (High accuracy control)
4. Electromagnetic cooking device

Notice

In the absence of confirmation by device specification sheets, SHARP takes no responsibility for any defects that may occur in equipment using any SHARP device shown in catalogs, data books, etc. Contact SHARP in order to obtain the latest device specification sheets before using any SHARP device.

Internal Connection Diagram

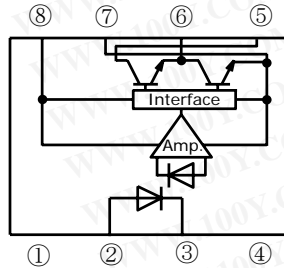

- ① NC
- ② Anode
- ③ Cathode
- ④ NC
- ⑤ O₁
- ⑥ O₂
- ⑦ GND
- ⑧ V_{cc}

勝特力材料 886-3-5753170
 勝特力电子(上海) 86-21-54151736
 勝特力电子(深圳) 86-755-83298787
[Http://www.100y.com.tw](http://www.100y.com.tw)

Outline Dimensions

(Unit : mm)

1. Through-Hole [ex. PC923LONSZ]
 product mass : 0.55g

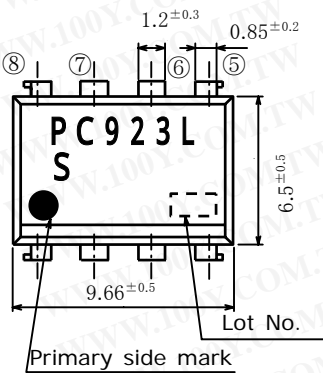

2. SMT Gullwing Lead-Form [ex. PC923LONIP]
 product mass : 0.51g

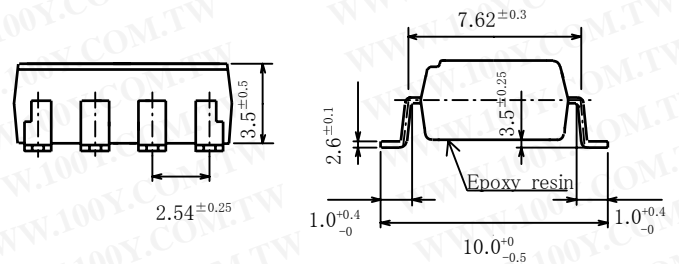
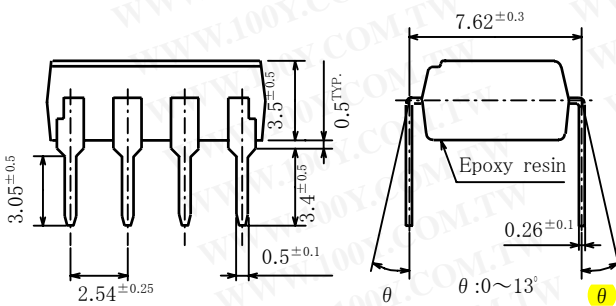
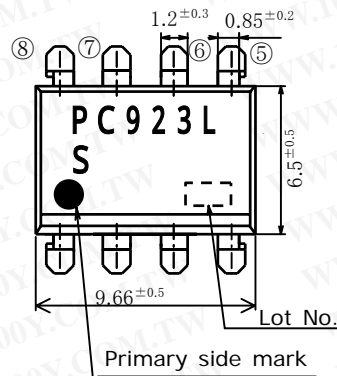

• Lot No. (2digit) code

1st digit				2nd digit	
Year of production				Month of production	
A.D	Mark	A.D	Mark	Month	Mark
1990	A	2002	P	January	1
1991	B	2003	R	February	2
1992	C	2004	S	March	3
1993	D	2005	T	April	4
1994	E	2006	U	May	5
1995	F	2007	V	June	6
1996	H	2008	W	July	7
1997	J	2009	X	August	8
1998	K	2010	A	September	9
1999	L	2011	B	October	O
2000	M	2012	C	November	N
2001	N	:	:	December	D

• Weekly code

1st Week	1
2nd Week	2
3rd Week	3
4th Week	4
5th and,6th Week	5

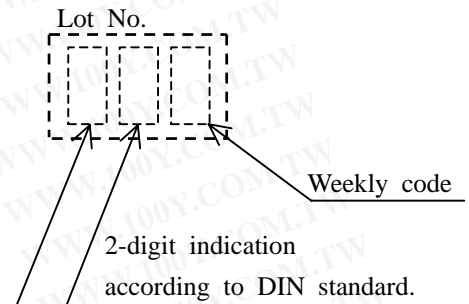

■ Absolute Maximum Ratings

				Ta=25°C	
	Parameter	Symbol	Rating	Unit	
Input	*1 Forward current	I _F	20	mA	
	Reverse voltage	V _R	5	V	
	Supply voltage	V _{CC}	35	V	
Output	O ₁ Output current	I _{O1}	0.1	A	
	*4 O ₁ Peak output current	I _{O1P}	0.6	A	
	O ₂ Output current	I _{O2}	0.1	A	
	*4 O ₂ Peak output current	I _{O2P}	0.6	A	
	O ₁ Output voltage	V _{O1}	35	V	
	*2 Power dissipation	P _o	500	mW	
	*3 Total power dissipation	P _{tot}	550	mW	
	*5 Isolation voltage	V _{iso(rms)}	5.0	kV	
	Operating temperature	T _{stg}	-40 to +85	°C	
	Storage temperature	T _{stg}	-55 to +125	°C	
	Soldering temperature	T _{sol}	270 (For 10s)	°C	

*1,2,3 The derating factors of absolute maximum due to ambient temperature are shown in Fig.10,11.

*4 Pulse width ≤ 0.15 μs, Duty ratio : 0.01

*5 AC for 1min, 40 to 60%RH, Ta=25°C

■ Electro-optical Characteristics

(Unspecified : Ta=-40 to +85°C)

Parameter		Symbol	MIN.	TYP.	MAX.	Unit	Test circuit	Conditions	
Input	Forward voltage	V _{F1}	-	1.6	1.75	V	-	Ta=25°C, I _F =10mA	
		V _{F2}	1.2	1.5	-	V	-	Ta=25°C, I _F =0.2mA	
	Reverse current	I _R	-	-	10	μA	-	Ta=25°C, V _R =5V	
	Terminal capacitance	C _t	-	60	150	pF	-	Ta=25°C, V=0, f=1MHz	
Operating supply voltage range		V _{CC}	15	-	30	V	-		
Output	O ₁ Low level output voltage	V _{O1L}	-	0.2	0.4	V	(1)	V _{CC1} =12V, V _{CC2} =-12V, I _{O1} =0.1A, I _F =5mA	
	O ₂ High level output voltage	V _{O2H}	20	22	-	V	(2)	V _{CC} =V _{O1} =24V, I _{O2} =-0.1A, I _F =5mA	
	O ₂ Low level output voltage	V _{O2L}	-	0.5	0.8	V	(3)	V _{CC} =24V, I _{O2} =-0.1A, I _F =0mA	
	O ₁ Leak current	I _{O1L}	-	-	500	μA	(4)	V _{CC} =V _{O1} =35V, I _F =0mA	
	O ₂ Leak current	I _{O2L}	-	-	500	μA	(5)	V _{CC} =V _{O2} =35V, I _F =5mA	
	High level supply current *3	I _{CCH}	-	1.3	3.0	mA	(6)	V _{CC} =24V, I _F =5mA	
	Low level supply current *3	I _{CCL}	-	1.3	3.0	mA		V _{CC} =24V, I _F =0mA	
	"L H" threshold input current *2	I _{FLH}	0.3	1.5	3.0	mA	(7)	Ta=25°C, V _{CC} =24V	
0.2			-	5.0	V _{CC} =24V				
Isolation resistance		R _{ISO}	5×10 ¹⁰	10 ¹¹	-	Ω	-	Ta=25°C, DC=500V, 40 to 60%RH	
Transfer characteristics	Response time	"L H" propagation time	t _{PLH}	-	0.3	0.5	μs	(8)	Ta=25°C V _{CC} =24V, I _F =5mA, R _G =47Ω, C _G =3000pF
		"H L" propagation time	t _{PHL}	-	0.3	0.5			
		Rise time	t _r	-	0.2	0.5			
		Fall time	t _f	-	0.2	0.5			
Instantaneous common mode rejection voltage (High level output)		CM _H	-15	-	-	kV/μs	(9)	Ta=25°C, V _{CM} =1.5kV(p-p) I _F =5mA, V _{CC} =24V V _{O2H} =2.0V	
Instantaneous common mode rejection voltage (Low level output)		CM _L	15	-	-			Ta=25°C, V _{CM} =1.5kV(p-p) I _F =0mA, V _{CC} =24V V _{O2L} =2.0V	

*1 It shall connect a by-pass capacitor of 0.01 μF or more between V_{CC} (Pin No. 8) and GND (Pin No. 7) near the device, when it measures the transfer characteristics and the output side characteristics.

*2 I_{FLH} is the value of forward current when output becomes from "L" to "H".

*3 O₂ Output pin is open (please refer to the Design guide for Photocouplers).

■ Truth Table

Input	O ₂ Output	Tr1	Tr2
ON	High level	ON	OFF
OFF	Low level	OFF	ON

勝特力材料 886-3-5753170
 勝特力电子(上海) 86-21-54151736
 勝特力电子(深圳) 86-755-83298787
[Http://www.100y.com.tw](http://www.100y.com.tw)

■ Test Circuit

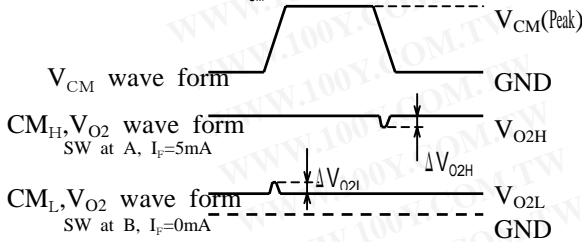
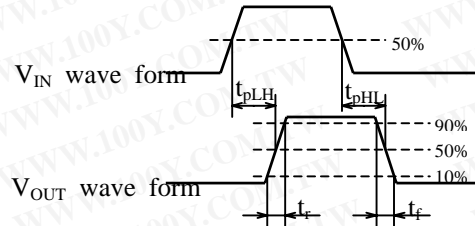
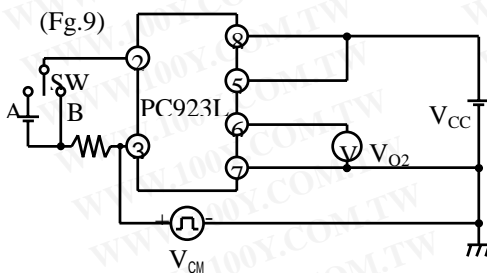
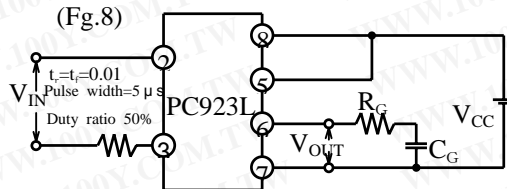
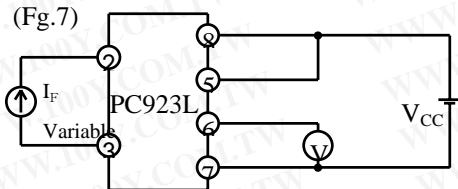
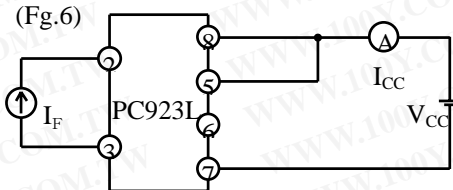
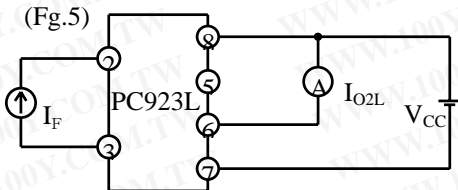
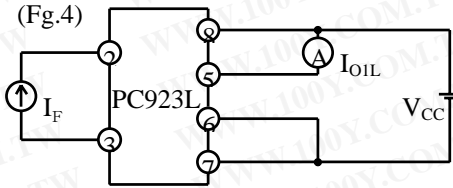
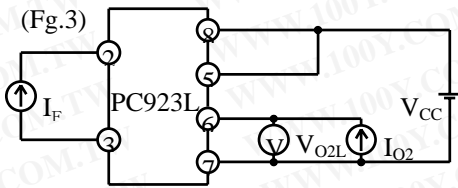
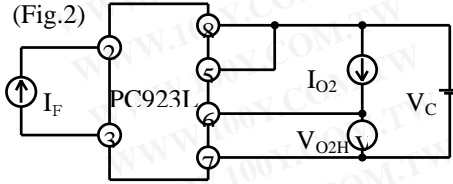
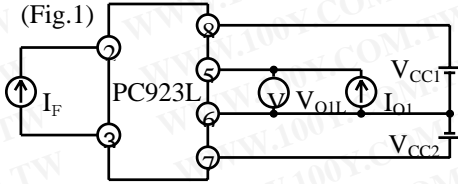

勝特力材料 886-3-5753170
 勝特力电子(上海) 86-21-54151736
 勝特力电子(深圳) 86-755-83298787
[Http://www.100y.com.tw](http://www.100y.com.tw)

勝特力材料 886-3-5753170
 勝特力电子(上海) 86-21-54151736
 勝特力电子(深圳) 86-755-83298787
[Http://www.100y.com.tw](http://www.100y.com.tw)

SHARP

PC923L

Fig.10 Forward Current vs. Ambient Temperature

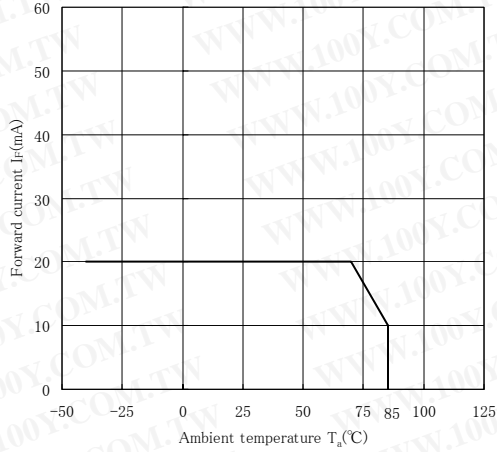

Fig.11 Power Dissipation vs. Ambient Temperature

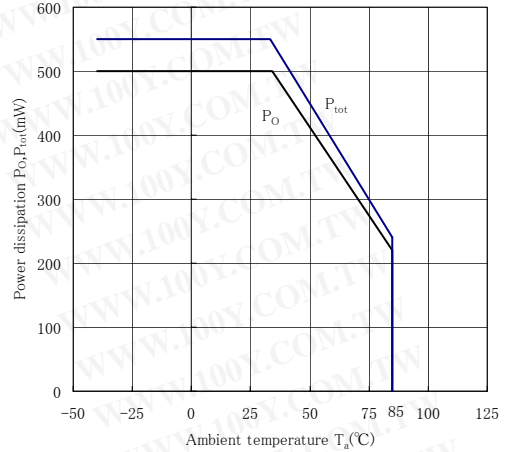

Fig.12 Forward Current vs. Forward Voltage

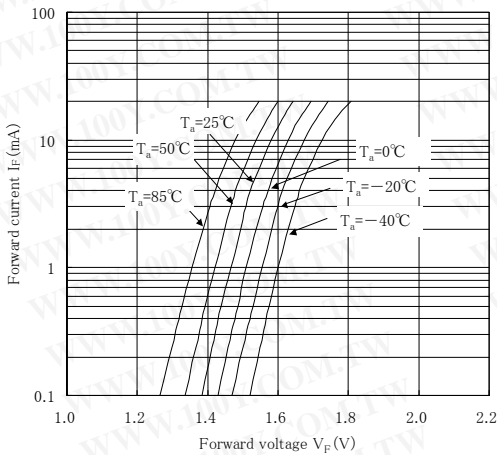

Fig.13 "Low→High Relative Threshold Input Current vs. Supply Voltage

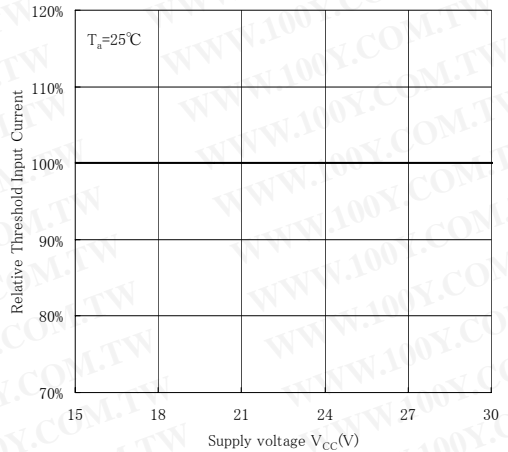

Fig.14 "Low→High Relative Threshold Input Current vs. Ambient Temperature

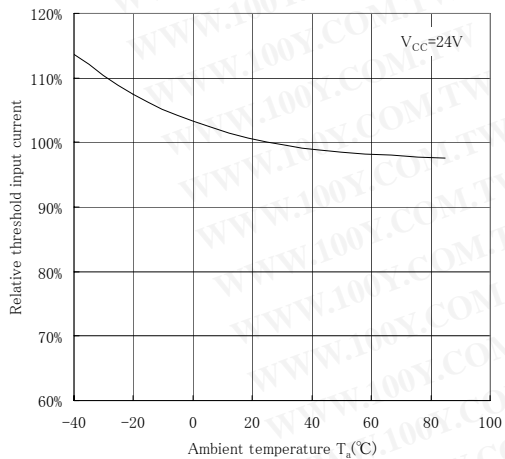

Fig.15 O_1 Low Level Output Voltage vs. O_1 Output Current

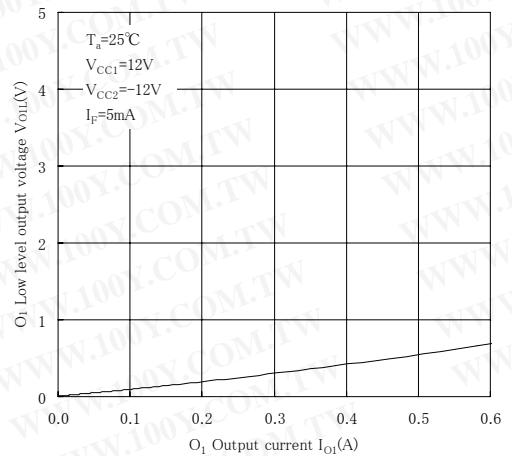

Fig.16 O₁ Low Level Output Voltage vs. Ambient Temperature

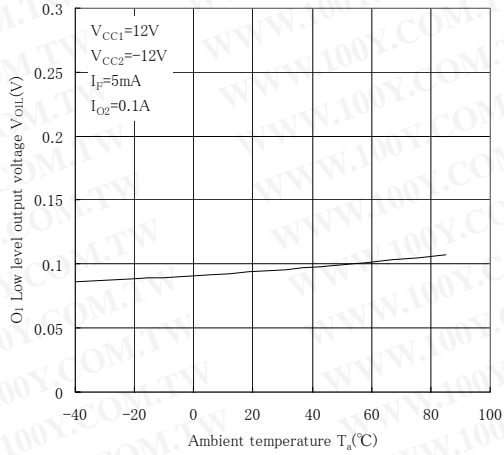

Fig.17 O₂ Output Voltage Drop Vs. O₂ Output Current

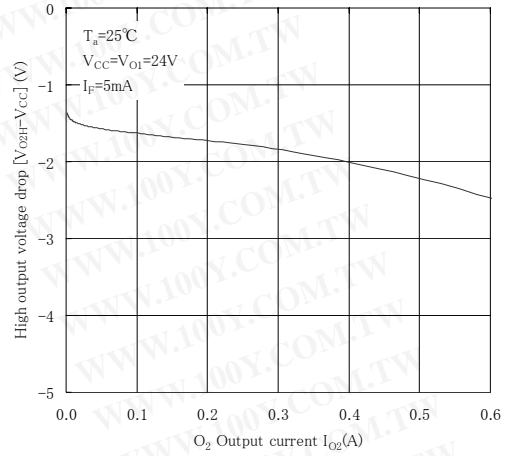

Fig.18 O₂ High Level Output Voltage vs. Supply Voltage

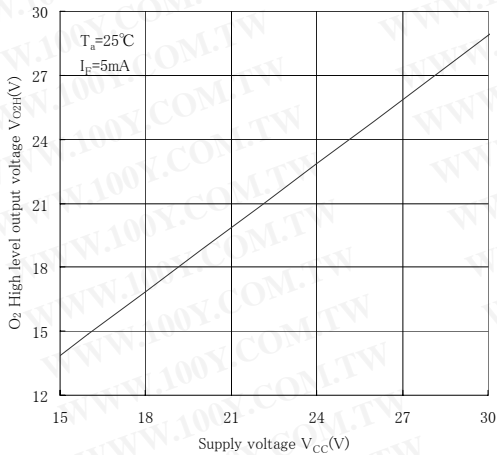

Fig.19 O₂ High Level Output Voltage vs. Ambient Temperature

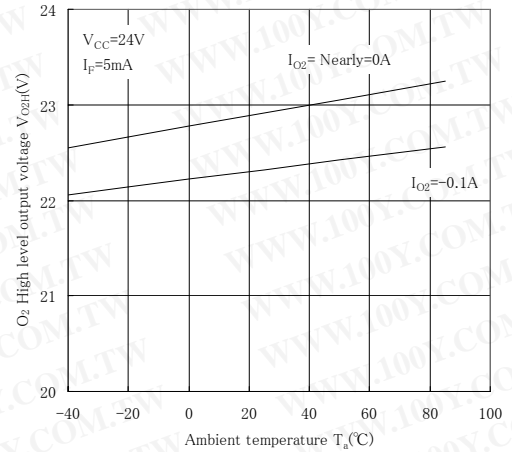

Fig.20 O₂ Low Level Output Voltage vs. O₂ Output Current

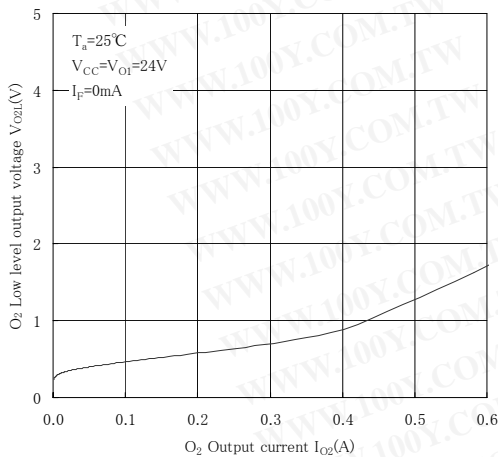

Fig.21 O₂ Low Level Output Voltage vs. Ambient Temperature

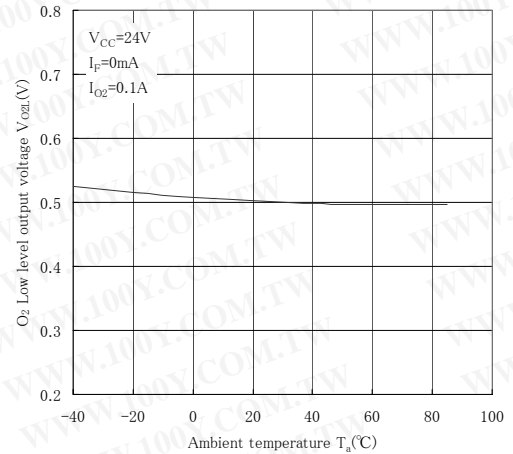

Fig.22 High Level Supply Current vs. Supply Voltage

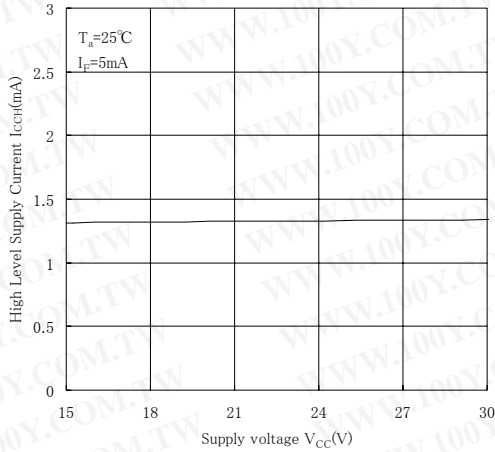

Fig.23 Low Level Supply Current vs. Supply Voltage

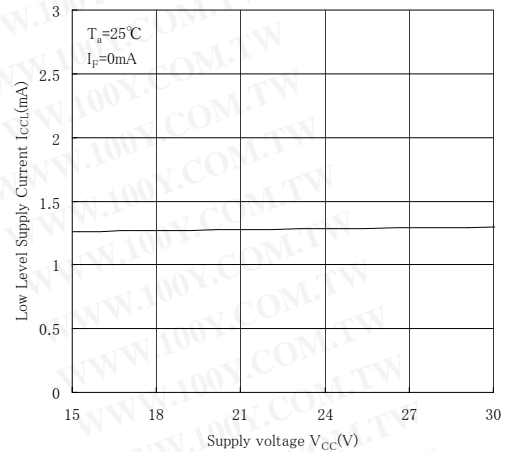

Fig.24 High Level Supply Current vs. Ambient Temperature

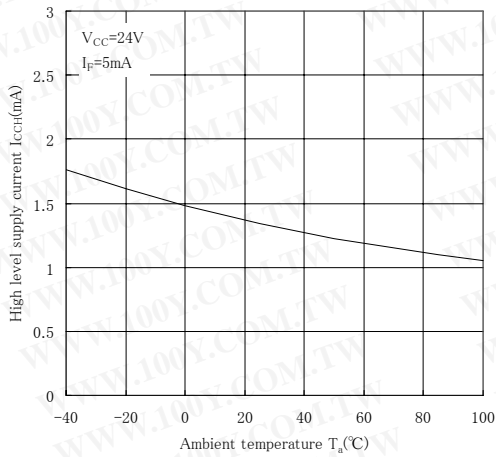

Fig.25 Low Level Supply Current vs. Ambient Temperature

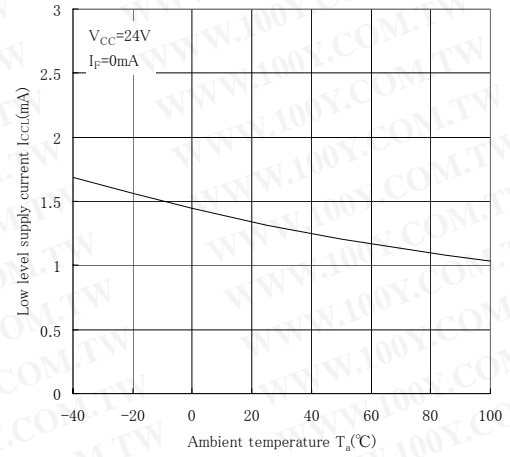

Fig.26 Propagation Delay Time vs. Forward Current

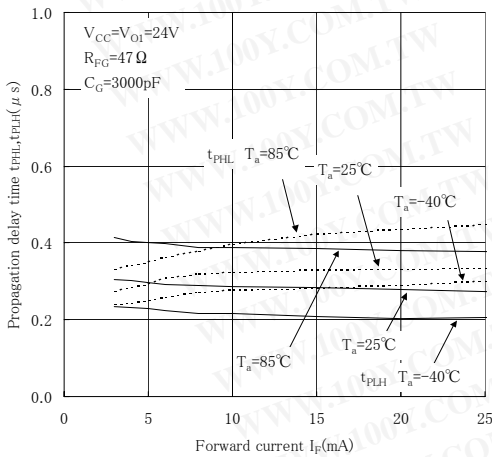
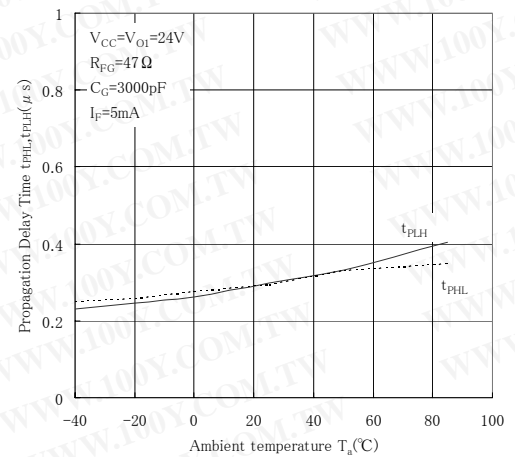

Fig.27 Propagation Delay Time vs. Ambient Temperature



■ Design Consideration

● Recommended operating condition (reference)

Parameter	Symbol	MIN.	TYP.	MAX.	Unit
Forward current	I_F	10	-	20	mA
Supply voltage	V_{CC}	15	-	30	V
Operating Temperature	T_{opr}	-40	-	70	°C

● Design guide

- In order to stabilize power supply line, we should certainly recommend to connect a by-pass capacitor of 0.01 μ F or more between V_{CC} and GND near the device.
- When steep voltage noise is applied between the primary side and the secondary side of the photocoupler, current flows or changes in the light emitting diode through a parasitic capacitance between the primary side and the secondary side of the photocoupler, then there is a case that miss operation occurs depending upon the applied noise level.

We should certainly recommend to use a by-pass capacitor between both terminals of the light emitting diode where used in a noisy environment.

- The detector which is used in this device, has parasitic diode between each pins and GND.

There are cases that miss operation or destruction possibly may be occurred if electric potential of any pin becomes below GND level even for instant.

Therefore it shall be recommended to design the circuit that electric potential of any pin does not become below GND level.

- This photocoupler is dedicated to the use for IGBT or MOS-FET Gate Drive. Please do not use this for the other application.

As mentioned below, when the input is on, if DC load (resistor etc) is connected between 2 output pin 6 and GND pin 7 and if the electric potential V_{o2} goes approx. 2V below than the electric potential V_{CC} pin 8 continuously, supply current I_{CC} may flow more than usually and go beyond power dissipation.

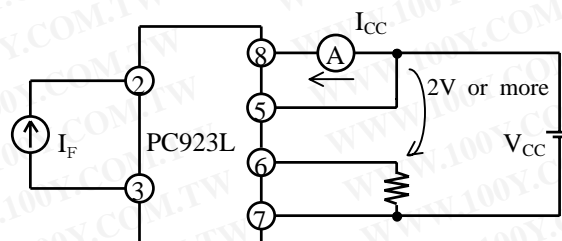

■ Design Condition**● Degradation**

- The LED used in the Photocoupler generally decreases the light emission power by operation. In case of long operation time, please design the circuit with considering the decrease of the light emission power of the LED. (50%/5years)

● Recommend Foot Print (reference)

Unit : mm

SMT Gullwing lead-form

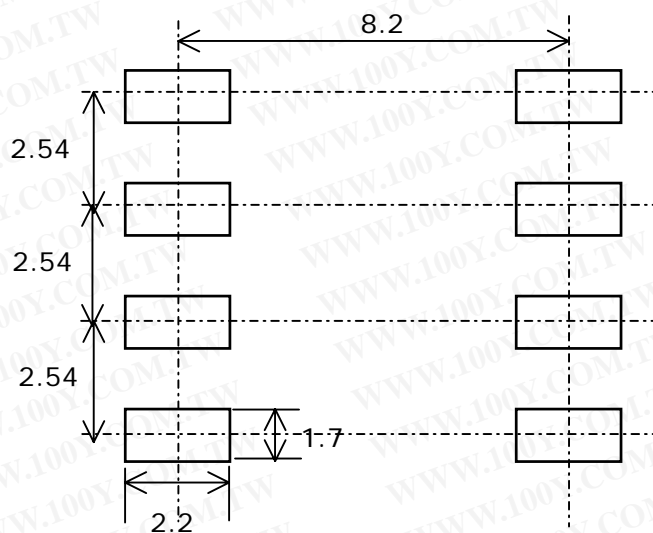

☆ For additional design assistance, please review our corresponding Optoelectronic Application Notes.

勝特力材料 886-3-5753170
勝特力电子(上海) 86-21-54151736
勝特力电子(深圳) 86-755-83298787
[Http://www.100y.com.tw](http://www.100y.com.tw)

■ Manufacturing Guideline

● Soldering Method

• Reflow Soldering :

Reflow soldering should follow the temperature profile below.

Soldering should not exceed the curve of temperature profile and time.

Please don't solder more than twice.

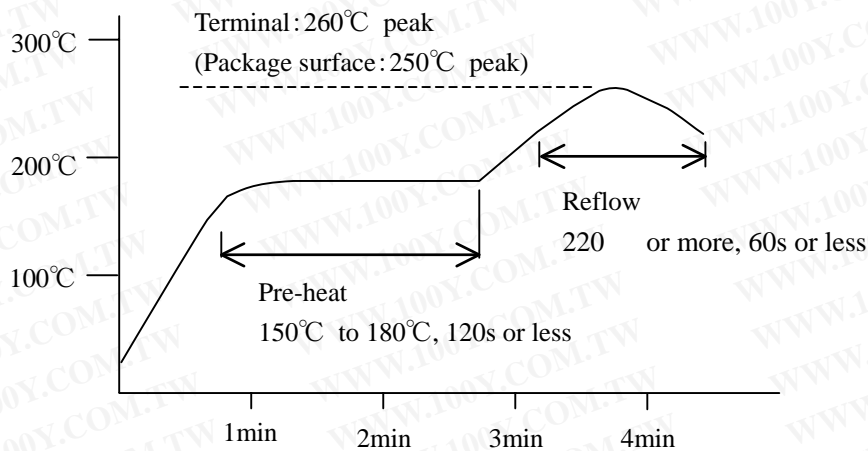

• Flow Soldering :

Due to SHARP's double transfer mold construction submersion in flow solder bath is allowed under the below listed guidelines.

Flow soldering should be completed below 270°C and within 10s.

Preheating is within the bounds of 100 to 150 °C and 30 to 80 s.

Please don't solder more than twice.

• Hand soldering :

Hand soldering should be completed within 3s when the point of solder iron is below 400°C.

Please don't solder more than twice.

• Other notices :

Please test soldering method in actual condition and make sure the soldering works fine, since the impact on the junction between the twice and PCB varies depending on the tooling and soldering conditions.

● Cleaning Instructions

- Solvent cleaning :
Solvent temperature should be 45°C or below.
Immersion time should be 3 min or less.
- Ultrasonic cleaning :
The impact on the device varies depending on the size of the cleaning bath, ultrasonic output, cleaning time, size of PCB and mounting method of the device.
Therefore, please make sure the device withstands the ultrasonic cleaning in actual condition in advance of mass production.
- Recommended solvent materials :
Ethyl alcohol, Methyl alcohol, Isopropyl alcohol
In cases the other type of solvent materials are intended to be used, please make sure they work fine in actual using conditions since some materials may erode the package resin.

● Presence of ODC

This product shall not contain the following materials.

And they are not used in the production process for this device.

Regulation substances : CFC_s, Halon, Carbon tetrachloride, 1.1.1-Trichloroethane (Methylchloroform)

Specific brominated flame retardants such as the PBBO_s, and PBB_s are not used in this product at all.

勝特力材料 886-3-5753170
勝特力电子(上海) 86-21-54151736
勝特力电子(深圳) 86-755-83298787
[Http://www.100y.com.tw](http://www.100y.com.tw)

■ Package specification**1. Sleeve package****• package materials**

Sleeve : HIPS (with and anti-static material)

Stopper : Styrene-Elastomer

• package method

MAX. 50 pcs. of products shall be package in a sleeve. Ends shall be fixed by stoppers.

MAX. 20 pcs. sleeves in one case

• Sleeve out line dimensions

Through-Hole or SMT Gullwing Lead-Form

Unit : mm

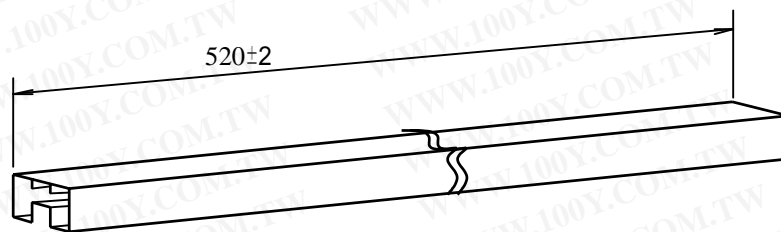
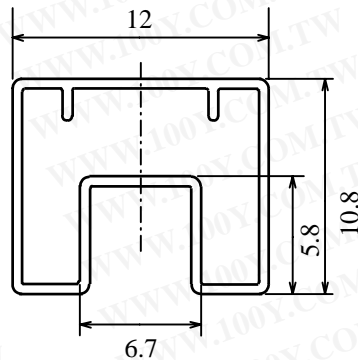

勝特力材料 886-3-5753170
勝特力电子(上海) 86-21-54151736
勝特力电子(深圳) 86-755-83298787
[Http://www.100y.com.tw](http://www.100y.com.tw)

2. Tape and Reel package

• SMT Package materials

Carrier tape : PS (with and anti-static material)

Cover tape : PET (three layer system)

Reel : PS

• package method

MAX. 100 pcs. of products shall be package in a carrier tape.

MAX. 4 reels are packed in one carton.

• Carrier tape structure and dimensions

SMT Gullwing Lead-Form

Unit : mm

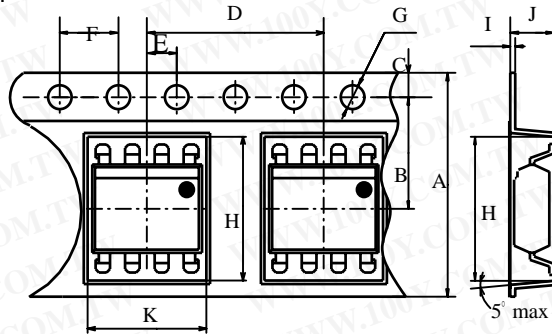

A	B	C	D	E	F	G	H
16.0±0.3	7.5±0.1	1.75±0.1	12.0±0.1	2.0±0.1	4.0±0.1	φ 1.5 ^{+0.1} ₋₀	10.4±0.1
I	J	K					
0.4±0.05	4.2±0.1	10.2±0.1					

• Reel structure and dimensions

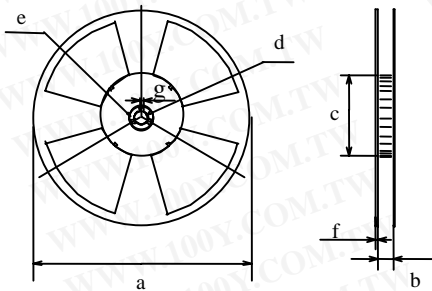

Dimension List

a	b	c	d
330	17.5±1.5	100±1.0	13±0.5
e	f	g	
23±1.0	2.0±0.5	2.0±0.5	

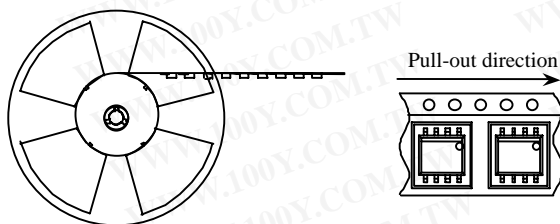

勝特力材料 886-3-5753170
 勝特力电子(上海) 86-21-54151736
 勝特力电子(深圳) 86-755-83298787
[Http://www.100y.com.tw](http://www.100y.com.tw)

■ Important Notices

- The circuit application examples in this publication are provided to explain representative applications of SHARP devices and are not intended to guarantee any circuit design or license any intellectual property rights. SHARP takes no responsibility for any problems related to any intellectual property right of a third party resulting from the use of SHARP's devices.
- Contact SHARP in order to obtain the latest device specification sheets before using any SHARP device. SHARP reserves the right to make changes in the specifications, characteristics, data, materials, structure, and other contents described herein at any time without notice in order to improve design or reliability. Manufacturing locations are also subject to change without notice.
- Observe the following points when using any devices in the publication. SHARP takes no responsibility for damage caused by improper use of the devices which does not meet the conditions and absolute maximum ratings to be used specified in the relevant specification sheet nor meet the following conditions:
 - (i) The devices in this publication are designed for use in general electronic equipment designs such as:
 - Personal computers
 - Office automation equipment
 - Telecommunication equipment [terminal]
 - Test and measurement equipment
 - Industrial control
 - Audio visual equipment
 - Consumer electronics
 - (ii) Measures such as fail-safe function and redundant design should be taken to ensure reliability and safety when SHARP devices are used for or in connection with equipment that requires higher reliability such as:
 - Transportation control and safety equipment (i.e., aircraft, trains, automobiles, etc.)
 - Traffic signals
 - Gas leakage sensor breakers
 - Alarm equipment
 - Various safety devices, etc.
 - (iii) SHARP devices shall not be used for or in connection with equipment that requires an extremely high level of reliability and safety such as:
 - Space applications
 - Telecommunication equipment [trunk lines]
 - Nuclear power control equipment
 - Medical and other life support equipment (e.g., scuba).
- If the SHARP device listed in this publication fall within the scope of strategic products described in the Foreign Exchange and Foreign Trade Law of Japan, it is necessary to obtain approval to export such SHARP devices.
- This publication is the proprietary product of SHARP and is copyrighted, with all rights reserved. Under the copyright laws, no part of this publication may be reproduced or transmitted in any form or by any means, electronic or mechanical, for any purpose, in whole or in part, without the express written permission of SHARP. Express written permission is also required before any use or this publication may be made by a third party.
- Contact and consult with a SHARP representative if there are any questions about the contents of this publication.

勝特力材料 886-3-5753170
勝特力电子(上海) 86-21-54151736
勝特力电子(深圳) 86-755-83298787
[Http://www.100y.com.tw](http://www.100y.com.tw)