

# SHARP

SYSTEM DEVICE DIVISION I  
ELECTRONIC COMPONENTS AND DEVICES GROUP  
SHARP CORPORATION

## SPECIFICATION

DEVICE SPECIFICATION FOR

PHOTOCOUPLER

MODEL No.

PC815

Business dealing name

PC815XNNSZ0F

PC815XNYSZ0F

勝特力材料 886-3-5753170  
勝特力电子(上海) 86-21-34970699  
勝特力电子(深圳) 86-755-83298787  
[Http://www.100y.com.tw](http://www.100y.com.tw)

Specified for \_\_\_\_\_

Enclosed please find copies of the Specifications which consists of 15 pages including cover.  
This specification sheets and attached sheets shall be both side copy.  
After confirmation of the contents, please be sure to send back  copies of the Specifications  
with approving signature on each.

CUSTOMER'S APPROVAL

PRESENTED

DATE

DATE

July 21, 2009

BY

BY

M. Kubo

for

M. Kubo,  
Department General Manager of  
Development Dept. IV  
System Device Div. I  
Electronic Components and Devices Group  
SHARP CORPORATION

# REFERENCE

PC815XNNSZ0F

Product name : PHOTOCOUPLER

勝特力材料 886-3-5753170  
勝特力电子(上海) 86-21-34970699  
勝特力电子(深圳) 86-755-83298787  
[Http://www.100y.com.tw](http://www.100y.com.tw)

Model No. : PC815

Business dealing name

PC815XNNSZ0F | PC815XNYSZ0F

1. These specification sheets include materials protected under copyright of Sharp Corporation ("Sharp"). Please do not reproduce or cause anyone to reproduce them without Sharp's consent.
2. When using this product, please observe the absolute maximum ratings and the instructions for use outlined in these specification sheets, as well as the precautions mentioned below. Sharp assumes no responsibility for any damage resulting from use of the product which does not comply with the absolute maximum ratings and the instructions included in these specification sheets, and the precautions mentioned below.

(Precautions)

- (1) This product is designed for use in the following application areas ;

⎧ · OA equipment    Audio visual equipment    · Home appliances  
  · Telecommunication equipment (Terminal)    · Measuring equipment  
  · Tooling machines    · Computers

If the use of the product in the above application areas is for equipment listed in paragraphs (2) or (3), please be sure to observe the precautions given in those respective paragraphs.

- (2) Appropriate measures, such as fail-safe design and redundant design considering the safety design of the overall system and equipment, should be taken to ensure reliability and safety when this product is used for equipment which demands high reliability and safety in function and precision, such as ;

⎧ · Transportation control and safety equipment (aircraft, train, automobile etc.)  
  · Traffic signals    · Gas leakage sensor breakers    · Rescue and security equipment  
  · Other safety equipment

- (3) Please do not use this product for equipment which require extremely high reliability and safety in function and precision, such as ;

⎧ · Space equipment    · Telecommunication equipment (for trunk lines)  
  · Nuclear power control equipment    · Medical equipment

- (4) Please contact and consult with a Sharp sales representative if there are any questions regarding interpretation of the above three paragraphs.

3. Please contact and consult with a Sharp sales representative for any questions about this product.

# REFERENCE

PC815XNNSZ0F

## 1. Application

This specification applies to the outline and characteristics of photocoupler Model No. PC815 (Lead-Free Type).

## 2. Outline

Refer to the attached sheet, page 4.

## 3. Ratings and characteristics

Refer to the attached sheet, page 5, 6.

## 4. Reliability

Refer to the attached sheet, page 7.

## 5. Outgoing inspection

Refer to the attached sheet, page 8.

勝特力材料 886-3-5753170  
勝特力电子(上海) 86-21-34970699  
勝特力电子(深圳) 86-755-83298787  
[Http://www.100y.com.tw](http://www.100y.com.tw)

## 6. Supplement

6.1 Isolation voltage shall be measured in the following method.

- (1) Short between anode to cathode on the primary side and between collector to emitter on the secondary side.
- (2) The dielectric withstanding tester with zero-cross circuit shall be used.
- (3) The wave form of applied voltage shall be a sine wave.  
(It is recommended that the isolation voltage be measured in insulation oil.)

## 6.2 Package specifications

Refer to the attached sheet, page 9, 10.

## 6.3 Business dealing name

("O" mark indicates business dealing name of ordered product)

Product	Business dealing name	Remark
	PC815XNNSZ0F	
	PC815XNYSZ0F	Applied to product as a option (Attachment-2-1 to 2-3.)

## 6.4 This Model is approved by UL.

Approved Model No. : PC815

UL file No. : E64380

## 6.5 This product is not designed against irradiation.

This product is assembled with electrical input and output.

This product incorporates non-coherent light emitting diode.

## 6.6 ODS materials

This product shall not contain the following materials.

Also, the following materials shall not be used in the production process for this product.

Materials for ODS : CFCS, Halon, Carbon tetrachloride, 1,1,1-Trichloroethane (Methyl chlorofom)

## 6.7 Specified brominated flame retardants

Specified brominated flame retardants (PBB and PBDE) are not used in this device at all.

# REFERENCE

PC815XNNS20F

## 6.8 Compliance with each regulation

### (1) The RoHS directive (2002/95/EC)

This product complies with the RoHS directive (2002/95/EC).

Object substances: mercury, lead, cadmium, hexavalent chromium, polybrominated biphenyls (PBB) and polybrominated diphenyl ethers (PBDE)

### (2) Content of six substances specified in Management Methods for Control of Pollution Caused by Electronic Information Products Regulation (Chinese : 电子信息产品污染控制管理办法).

Category	Toxic and hazardous substances					
	Lead (Pb)	Mercury (Hg)	Cadmium (Cd)	Hexavalent chromium (Cr <sup>6+</sup> )	Polybrominated biphenyls (PBB)	Polybrominated diphenyl ethers (PBDE)
Photocoupler	✓	✓	✓	✓	✓	✓

✓: indicates that the content of the toxic and hazardous substance in all the homogeneous materials of the part is below the concentration limit requirement as described in SJ/T 11363-2006 standard.

## 7. Notes

Precautions for photocouplers : Attachment-1

勝特力材料 886-3-5753170  
勝特力电子(上海) 86-21-34970699  
勝特力电子(深圳) 86-755-83298787  
[Http://www.100y.com.tw](http://www.100y.com.tw)

# REFERENCE

PC815XNNSZ0F

## 2. Outline

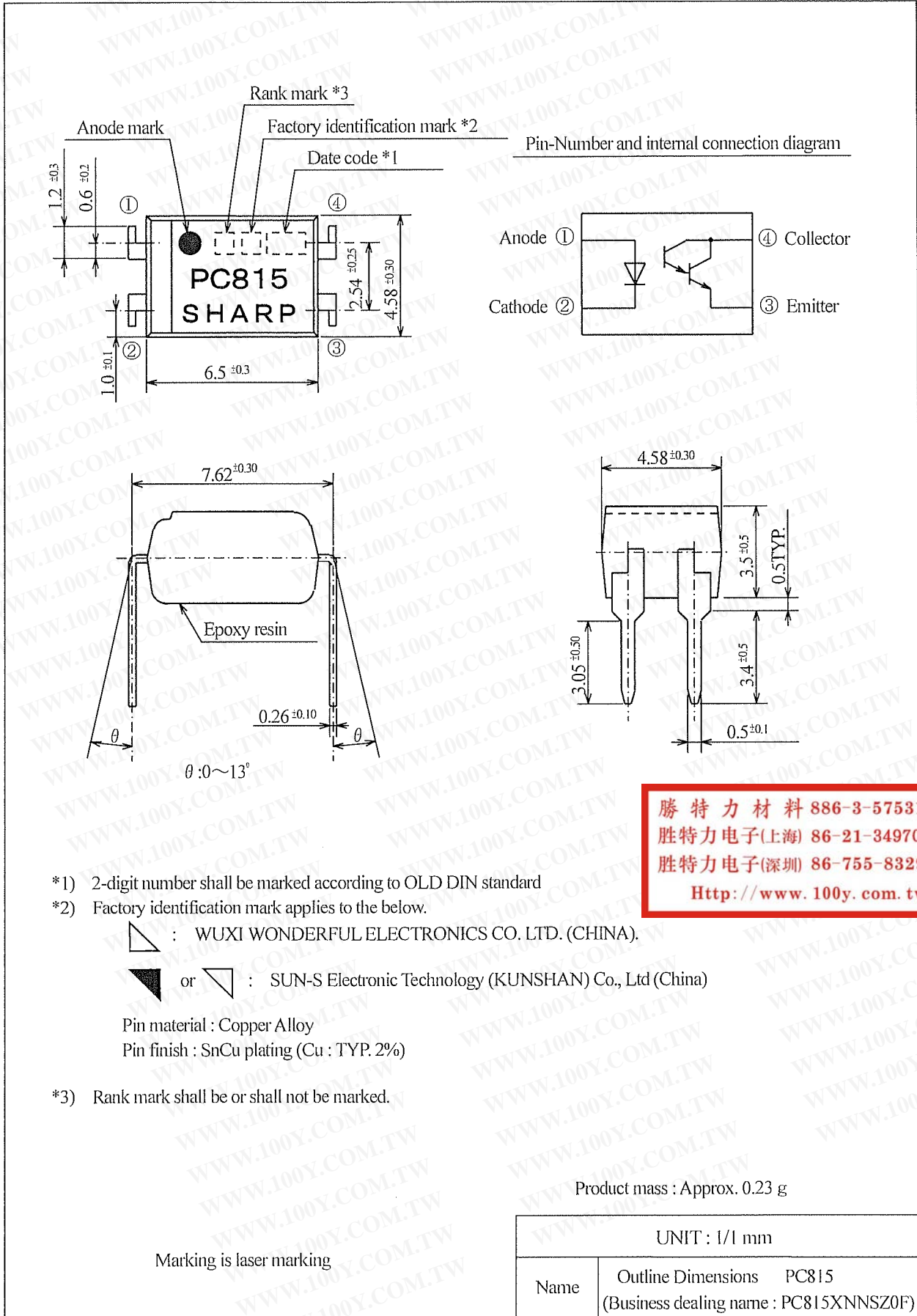

# REFERENCE

PC815XNNSZ0F

**勝特力材料 886-3-5753170**  
**勝特力电子(上海) 86-21-34970699**  
**勝特力电子(深圳) 86-755-83298787**  
[Http://www.100y.com.tw](http://www.100y.com.tw)

### 3. Ratings and characteristics

#### 3.1 Absolute maximum ratings

Ta=25°C

Parameter		Symbol	Rating	Unit
Input	*1 Forward current	$I_F$	50	mA
	*2 Peak forward current	$I_{FM}$	1	A
	Reverse voltage	$V_R$	6	V
	*1 Power dissipation	P	70	mW
Output	Collector-emitter voltage	$V_{CEO}$	35	V
	Emitter-collector voltage	$V_{ECO}$	6	V
	Collector current	$I_c$	80	mA
	*1 Collector power dissipation	$P_c$	150	mW
*1 Total power dissipation	$P_{tot}$	200	mW	
Operating temperature		$T_{opr}$	-30 to +100	°C
Storage temperature		$T_{stg}$	-55 to +125	°C
*3 Isolation voltage	$V_{iso(mms)}$	5	kV	
*4 Soldering temperature	$T_{sol}$	270	°C	

#### 3.1 Electro-optical characteristics

Ta=25°C

Parameter		Symbol	Condition	MIN.	TYP.	MAX.	Unit
Input	Forward voltage	$V_F$	$I_F=20mA$	-	1.2	1.4	V
	Peak forward voltage	$V_{FM}$	$I_{FM}=0.5A$	-	-	3.0	V
	Reverse current	$I_R$	$V_R=4V$	-	-	10	$\mu A$
	Terminal capacitance	$C_t$	$V=0, f=1kHz$	-	30	250	pF
Output	Dark current	$I_{CEO}$	$V_{CE}=10V, I_F=0$	-	-	1000	nA
	Collector-emitter breakdown voltage	$BV_{CEO}$	$I_c=0.1mA, I_F=0$	35	-	-	V
	Emitter-collector breakdown voltage	$BV_{ECO}$	$I_E=10\mu A, I_F=0$	6	-	-	V
Transfer characteristics	Collector current	$I_c$	$I_F=1mA, V_{CE}=2V$	6	16	75	mA
	Collector-emitter saturation voltage	$V_{CE(sat)}$	$I_F=20mA, I_c=5mA$	-	0.8	1.0	V
	Isolation resistance	$R_{ISO}$	DC500V 40 to 60%RH	$5 \times 10^{10}$	$10^{11}$	-	$\Omega$
	Floating capacitance	$C_f$	$V=0, f=1MHz$	-	0.6	1.0	pF
	Cut-off frequency	$f_c$	$V_{CE}=2V, I_c=2mA$ $R_L=100\Omega, -3dB$	1	6	-	kHz
	Rise time	$t_r$	$V_{CE}=2V, I_c=10mA$	-	60	300	$\mu s$
Fall time	$t_f$	$R_L=100\Omega$	-	53	250	$\mu s$	

\*1 The derating factors of absolute maximum ratings due to ambient temperature are shown in Fig. 1 to 4.

\*2 Pulse width  $\leq 100 \mu s$ , Duty ratio : 0.001 (Refer to Fig. 5)

\*3 AC for 1 min, 40 to 60%RH

\*4 For 10 s

# REFERENCE

PC815XNNSZ0F

(Fig.1) Forward current vs. ambient temperature

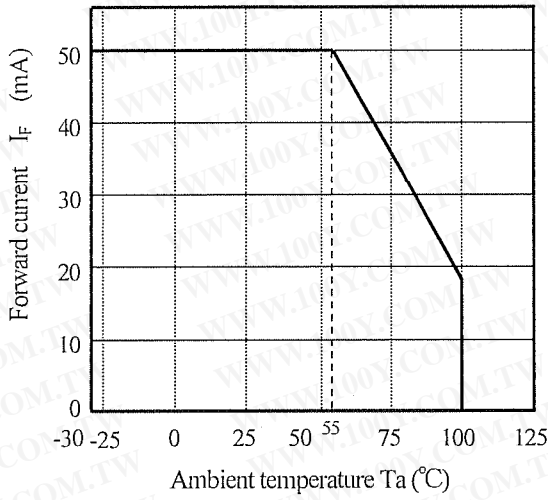

(Fig.2) Diode power dissipation vs. ambient temperature

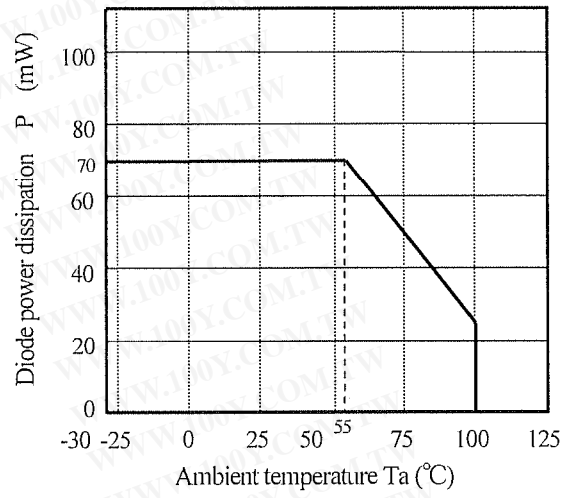

(Fig.3) Collector power dissipation vs. ambient temperature

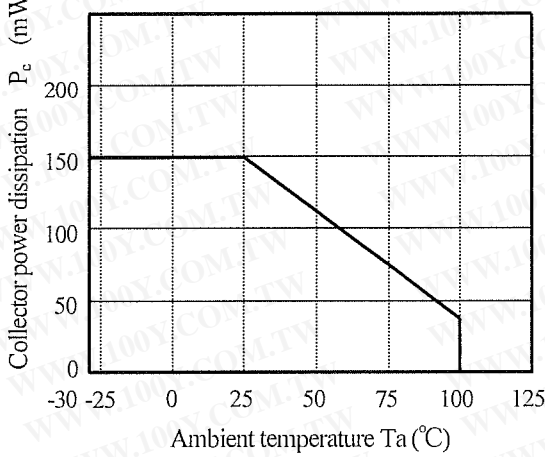

(Fig.4) Total power dissipation vs. ambient temperature

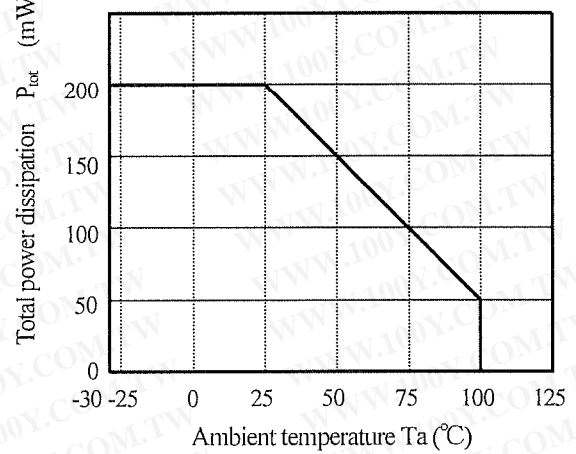

(Fig.5) Forward current vs. duty ratio  
Pulse width  $\leq 100\mu s$   
 $T_a = 25^\circ C$

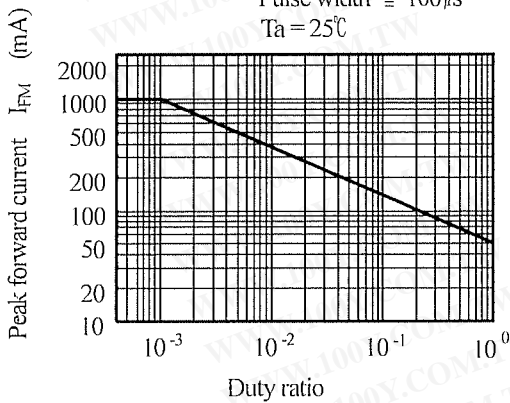

勝特力材料 886-3-5753170  
 勝特力电子(上海) 86-21-34970699  
 勝特力电子(深圳) 86-755-83298787  
[Http://www.100y.com.tw](http://www.100y.com.tw)

# REFERENCE

PC815XNNSZ0F

## 4. Reliability

The reliability of products shall satisfy items listed below.

Confidence level : 90%

LTPD : 10 or 20

Test Items	Condition	Failure Judgment Criteria	Samples (n) Defective (C)
Solderability	245±3°C, 5s	*2	n=11, C=0
Soldering heat	(Flow soldering) 270°C, 10 s	$V_F > U \times 1.2$ $I_R > U \times 2$ $I_{CEO} > U \times 2$ $I_C < L \times 0.7$ $V_{CE(sat)} > U \times 1.2$  U: Upper specification limit L: Lower specification limit	n=11, C=0
	(Soldering by hand) 400°C, 3 s		n=11, C=0
Terminal strength (Tension)	Weight: 5N 5 s/each terminal		n=11, C=0
Terminal strength (Bending) *3	Weight: 2.5N 2 times/each terminal		n=11, C=0
Mechanical shock	15km/s <sup>2</sup> , 0.5ms 3 times/±X, ±Y, ±Z direction		n=11, C=0
Variable frequency vibration	100 to 2000 to 100Hz/4 min 200m/s <sup>2</sup> 4 times/X, Y, Z direction		n=11, C=0
Temperature cycling	1 cycle -55 °C to +125 °C (30 min) (30 min) 20 cycles test		n=22, C=0
High temp. and high Humidity storage	+85°C, 85%RH, 1000h		n=22, C=0
High temp. storage	+125 °C, 1000h		n=22, C=0
Low temp. storage	-55 °C, 1000h		n=22, C=0
Operation life	I <sub>F</sub> =50mA, P <sub>tot</sub> =200mW T <sub>a</sub> =25 °C, 1000h	n=22, C=0	

\*1 Test method, conforms to EIAJ ED 4701.

\*2 The product whose not-soldered area is more than 5% for all of the dipped area, and/or whose pinholes or voids are concentrated on one place shall be judged defect.

\*3 Terminal bending direction is shown below.

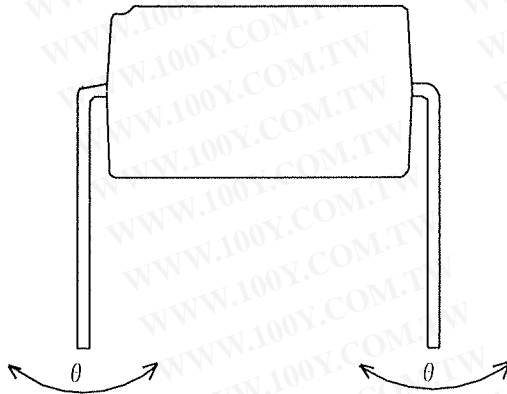

勝特力材料 886-3-5753170  
 勝特力电子(上海) 86-21-34970699  
 勝特力电子(深圳) 86-755-83298787  
[Http://www.100y.com.tw](http://www.100y.com.tw)

# REFERENCE

PC815XNNS20F

## 5. Outgoing inspection

### 5.1 Inspection items

#### (1) Electrical characteristics

$V_F$ ,  $I_R$ ,  $I_{CEO}$ ,  $V_{CE(sat)}$ ,  $I_c$ ,  $R_{ISO}$ ,  $V_{iso}$

#### (2) Appearance

### 5.2 Sampling method and Inspection level

A single sampling plan, normal inspection level II based on ISO 2859 is applied.

The AQL according to the inspection items are shown below.

Defect	Inspection item	AQL (%)
Major defect	Electrical characteristics Unreadable marking	0.065
Minor defect	Appearance defect except the above mentioned.	0.25

勝特力材料 886-3-5753170  
勝特力电子(上海) 86-21-34970699  
勝特力电子(深圳) 86-755-83298787  
[Http://www.100y.com.tw](http://www.100y.com.tw)

# REFERENCE

PC815XNNSZ0F

## 6.2 Packing specification

### 6.2.1 Package materials

No.	Name	Materials	Purposes
①	Sleeve	HIPS or ABS with preventing static electricity	Products packaged
②	Stopper	Styrene-Elastomer	Products fixed
③	Packing case	Corrugated cardboard	Sleeve packaged
④	Kraft tape	Paper	Lid of packaged case fixed
⑤	Label	Paper	Model No.,(Business dealing name),Lot No., Quantity, country of origin , Company name and inspection date specified

### 6.2.2 Package method

- (1) MAX. 100pcs. of products shall be packaged in a sleeve ① and both of sleeve edges shall be fixed by stoppers ②.
- (2) MAX. 20 sleeves (Product : 2000pcs.) above shall be packaged in a packing case ③.
- (3) The label ⑤ shall be put on the side of the packing case.
- (4) Case shall be closed with the lid and enclosed with kraft tape ④.

### 6.2.3 Sleeve package ① outline dimensions

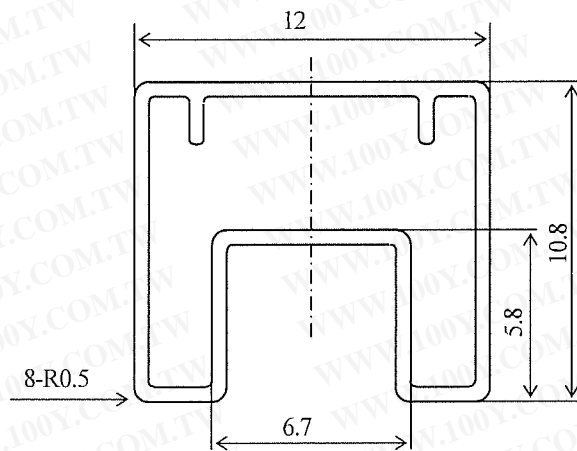

勝特力材料 886-3-5753170  
 勝特力电子(上海) 86-21-34970699  
 勝特力电子(深圳) 86-755-83298787  
[Http://www.100y.com.tw](http://www.100y.com.tw)

(Unit :mm)

- Note
- 1) Thickness :  $0.5 \pm 0.2$ mm
  - 2) Process with applying antistatic agent.
  - 3) Unless otherwise specified tolerances shall be  $\pm 0.5$ mm.  
 (However except for deformation due to the stopper in sleeve.)

# REFERENCE

PC815XNNSZ0F

## 6.2.4 Packing outer case outline dimensions

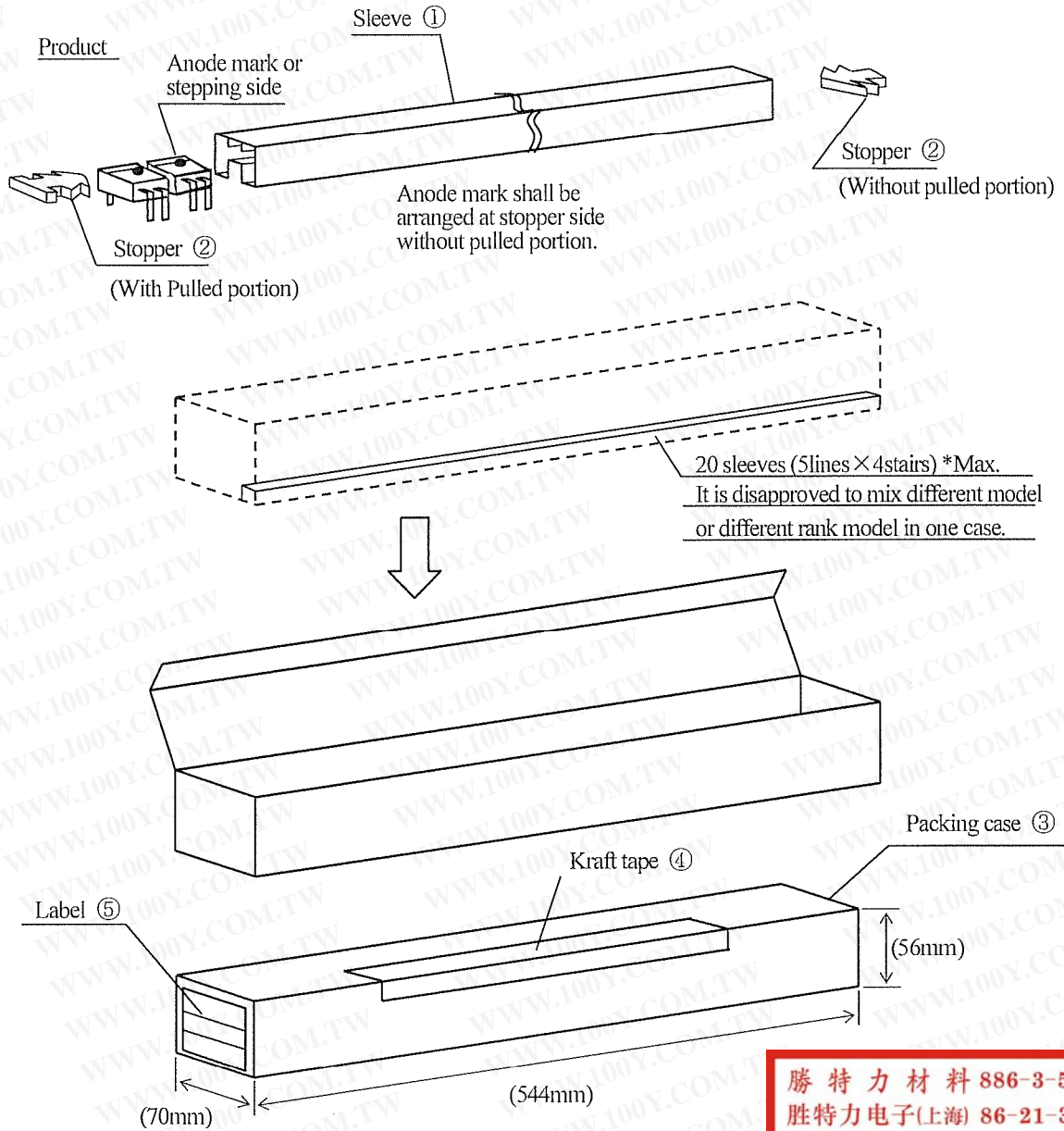

勝特力材料 886-3-5753170  
 勝特力电子(上海) 86-21-34970699  
 勝特力电子(深圳) 86-755-83298787  
[Http://www.100y.com.tw](http://www.100y.com.tw)

Regular packing mass : Approx. 860g

( ) : Reference dimensions

# REFERENCE

PC815XNNSZ0F

## Precautions for Photocouplers

### 1. Cleaning

(1) Solvent cleaning : Solvent temperature 45°C or less  
Immersion for 3 min or less

(2) Ultrasonic cleaning : The effect to device by ultrasonic cleaning differs by cleaning bath size, ultrasonic power output, cleaning time, PCB size or device mounting condition etc.  
Please test it in actual using condition and confirm that any defect doesn't occur before starting the ultrasonic cleaning.

(3) Applicable solvent : Ethyl alcohol, Methyl alcohol, Isopropyl alcohol  
When the other solvent is used, there are cases that the packaging resin is eroded.  
Please use the other solvent after thorough confirmation is performed in actual using condition.

### 2. Circuit design

(1) The LED used in the Photocoupler generally decreases the light emission power by operation.  
In case of long operation time, please design the circuit in consideration of the degradation of the light emission power of the LED. (50%/5years)

(2) There are cases that the deviation of the CTR and the degradation of the relative light emission power of the LED increase when the setting value of  $I_F$  is less than 1.0mA. Please design the circuit in consideration of this point.

### 3. Precautions for Soldering

(1) In the case of flow soldering (Whole dipping is possible)  
It is recommended that flow soldering should be at 270°C or less for 10 s or less  
(Pre-heating : 100 to 150°C, 30 to 80s). (2 times or less)

(2) In the case of hand soldering  
What is done on the following condition is recommended.( 2 times or less)  
Soldering iron temperature : 400°C or less  
Time : 3s or less

(3) Other precautions  
Depending on equipment and soldering conditions (temperature, Using solder etc.),  
the effect to the device and the PCB is different.  
Please confirm that there is no problem on the actual use conditions in advance.

勝特力材料 886-3-5753170  
勝特力电子(上海) 86-21-34970699  
勝特力电子(深圳) 86-755-83298787  
[Http://www.100y.com.tw](http://www.100y.com.tw)

# REFERENCE

PC815XNYSZ0F

1. This specification shall be applied to photocoupler, Model No. PC815 as an option.
2. Applicable Models (Business dealing name)  
PC815XNYSZ0F
3. The relevant models are the models Approved by VDE according to DIN EN 60747-5-2.  
Approved Model No. : PC815  
VDE approved No. : 40008087 (According to the specification DIN EN 60747-5-2)

• Operating isolation voltage	$U_{IORM}$	: 890V (Peak)
• Transient voltage		: 9000V (Peak)
• Pollution		: 2
• Clearances distance (Between input and output)		: 6.4 mm (MIN.)
• Creepage distance (Between input and output)		: 6.4 mm (MIN.)
• Isolation thickness between input and output		: 0.15mm (MIN.)
• Tracking-proof		: CTI 175
• Safety limit values	Current (Isi)	: 200mA (Diode side)
	Power (Psi)	: 260mW (Phototransistor side)
	Temperature (Tsi)	: 150°C

In order to keep safety electric isolation of photocoupler, please set the protective circuit to keep within safety limit values when the actual application equipment troubled.

- Indication of VDE approval prints "  " on minimum unit package.

4. Outline Refer to the attachment-2-2.

5. Isolation specification according to EN 60747-5-2.

Parameter	Symbol	Condition	Rating	Unit	Remark
Class of environmental test	-	-	55/110/21	-	
Pollution	-	-	2	-	
Maximum operating isolation voltage	$U_{IORM}$ (PEAK)	-	890	V	
Partial discharge test voltage (Between input and output)					Refer to the Diagram 1,2 (Attachement-2-3)
Diagram 1	$U_{pr}$ (PEAK)	$t_p=10s, q_c<5pC$	1340	V	
Diagram 2		$t_p=1s, q_c<5pC$	1670	V	
Maximum over-voltage	$U_{IOTM}$ (PEAK)	$t_{in}=60s$	9000	V	
Safety maximum ratings					Refer to Fig 6,7 (Attachement-2-3)
1) Case temperature	Tsi	$I_f=0, P_c=0,$	150	°C	
2) Input current	Isi	$P_c=0$	200	mA	
3) Electric power (Output or Total power dissipation)	Psi	-	260	mW	
Isolation resistance (Test voltage between input and output ; DC500V)	$R_{ISO}$	$T_a=T_{si}$	MIN. $10^9$	Ω	
		$T_a=T_{opr}(MAX.)$	MIN. $10^{11}$		
		$T_a=25^\circ C$	MIN. $10^{12}$		

6. Precautions in performing isolation test

6.1 Partial discharge test methods shall be the ones according to the specifications of EN 60747-5-2

6.2 Please don't carry out isolation test ( $V_{iso}$ ) over  $U_{IOTM}$ . This product deteriorates isolation characteristics by partial discharge due to applying high voltage (ex.  $U_{IOTM}$ ).

And there is possibility that partial discharge occurs in operating isolation voltage. ( $U_{IORM}$ ).

# REFERENCE

PC815XNYSZ0F

勝特力材料 886-3-5753170  
 勝特力电子(上海) 86-21-34970699  
 勝特力电子(深圳) 86-755-83298787  
 Http://www.100y.com.tw

## 4. Outline

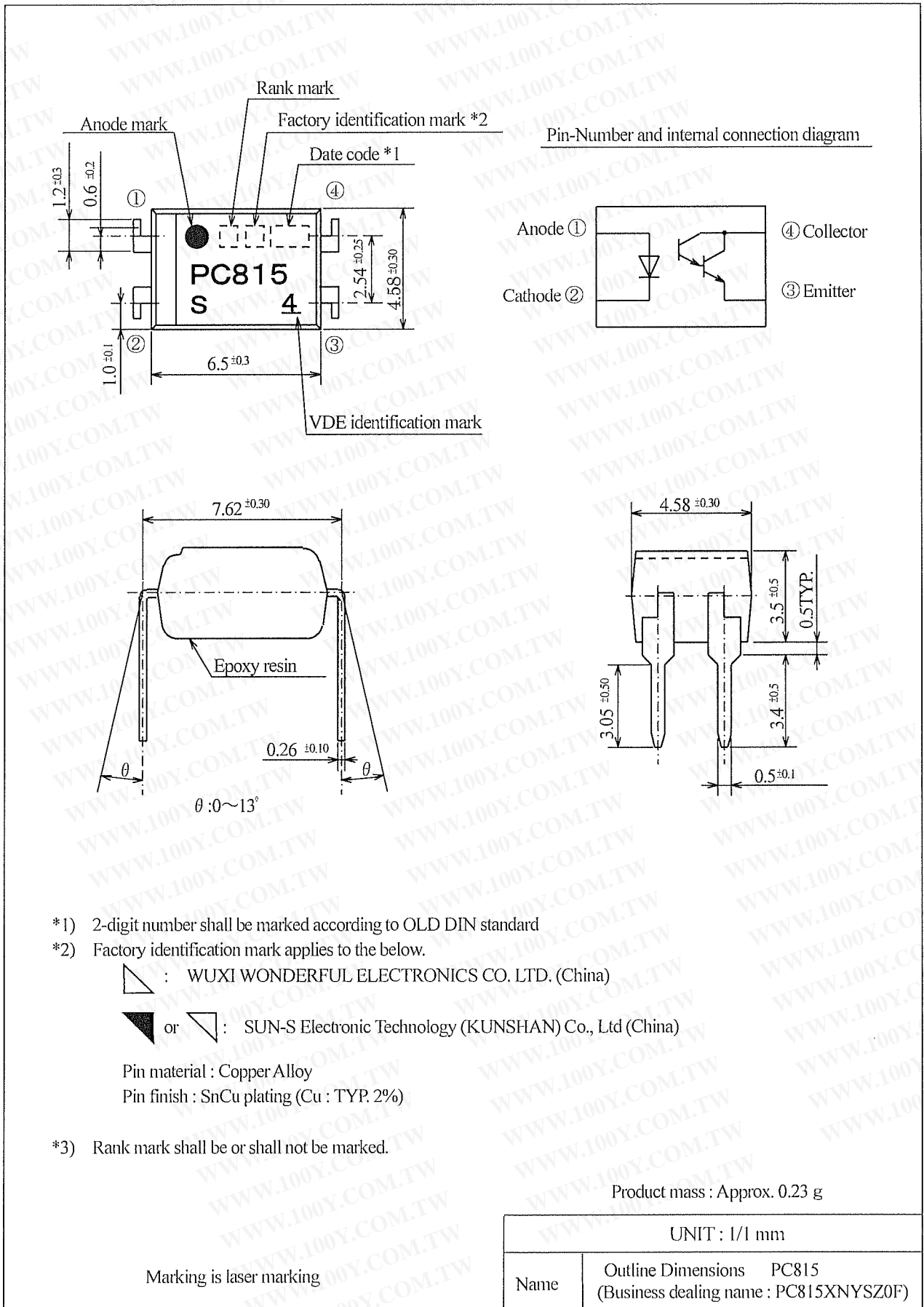

# REFERENCE

PC815XNYSZ0F

勝特力材料 886-3-5753170  
 勝特力电子(上海) 86-21-34970699  
 勝特力电子(深圳) 86-755-83298787  
[Http://www.100y.com.tw](http://www.100y.com.tw)

Method of Diagram 1: Breakdown test (Apply to type test and sampling test)

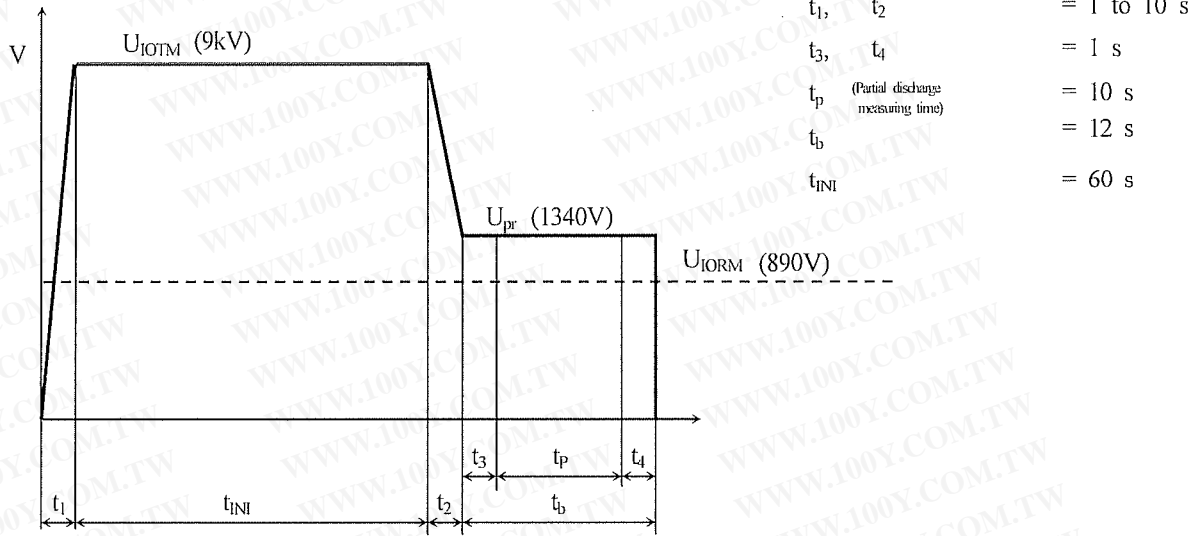

Method of Diagram 2: Non breakdown test (Apply to all device test)

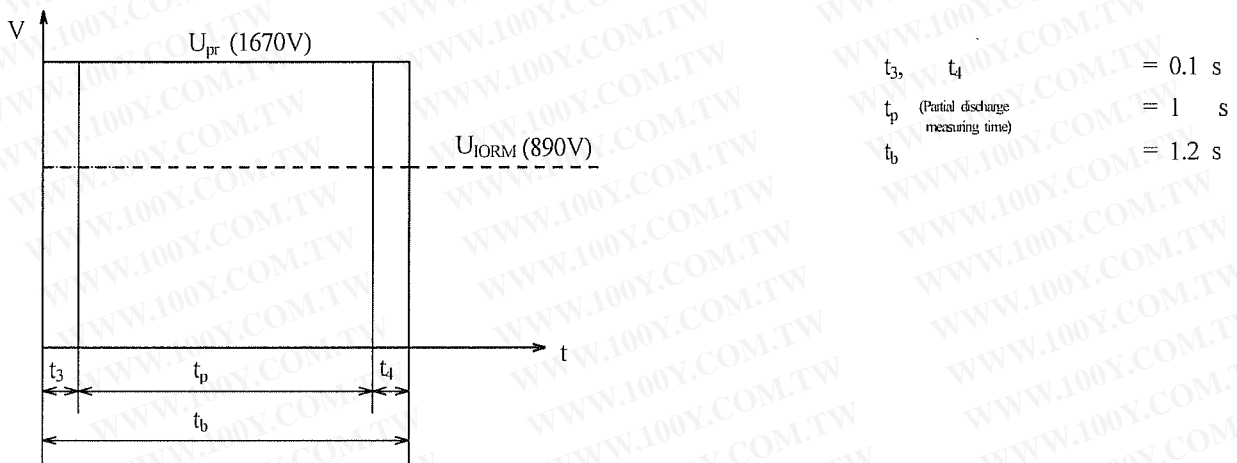

(Fig.6) Safety maximum power dissipation vs. ambient temperature (When failed)

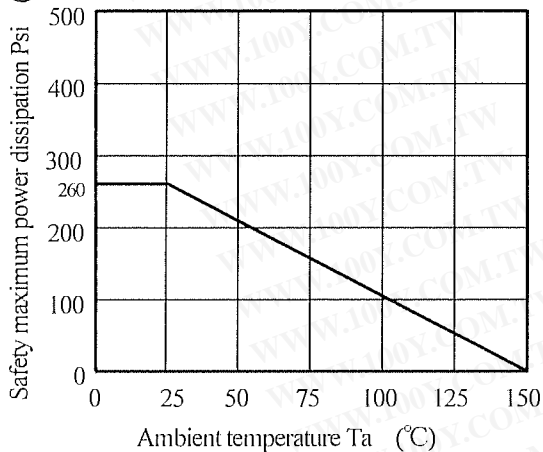

(Fig. 7) Safety maximum forward current vs. ambient temperature (When failed)

