

PC725V

High Sensitivity, High Collector-emitter Voltage Type Photocoupler

- * Lead forming type (W type) and taping reel type (P type) are also available. (PC725W/PC725VP)
- ** TÜV (VDE0884) approved type as an option is also available.

■ Features

1. High collector-emitter voltage
($V_{CEO} : 300V$)
2. High current transfer ratio
(CTR : MIN. 1 000% at $I_F = 1mA$, $V_{CE} = 2V$)
3. High isolation voltage between input and output
($V_{ISO} : 5\ 000V_{rms}$)
4. Low collector dark current
($I_{CEO} : MAX. 10^{-6}A$ at $V_{CE} = 200V$)
5. Recognized by UL, file No. E64380

■ Applications

1. Telephone sets, telephone exchangers
2. Power apparatus switchboards
3. Numerical control machines
4. DC-DC SSRs, DC motor controllers

■ Outline Dimensions

(Unit : mm)

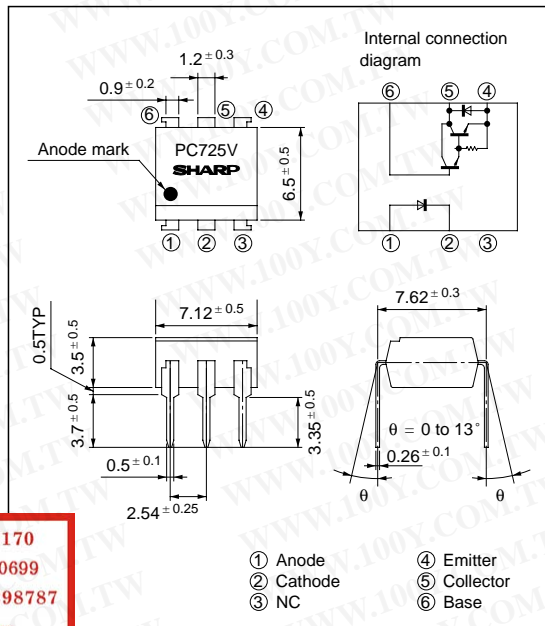

勝特力材料 886-3-5753170
 勝特力电子(上海) 86-21-34970699
 勝特力电子(深圳) 86-755-83298787
[Http://www.100y.com.tw](http://www.100y.com.tw)

■ Absolute Maximum Ratings

(T_a = 25°C)

	Parameter	Symbol	Rating	Unit
Input	Forward voltage	I_F	50	mA
	^{*1} Peak forward voltage	I_{FM}	1	A
	Reverse current	V_R	6	V
	Power dissipation	P	70	mW
Output	Collector-emitter voltage	V_{CEO}	300	V
	Collector-base voltage	V_{CBO}	300	V
	Emitter-base voltage	V_{EBO}	6	V
	Collector current	I_C	150	mA
	Collector current (reverse)	$-I_C$	10	mA
	Collector power dissipation	P_C	300	mW
	Total power dissipation	P_{tot}	350	mW
	^{*2} Isolation voltage	V_{iso}	5 000	V_{rms}
	Operating temperature	T_{opr}	- 25 to + 100	°C
	Storage temperature	T_{stg}	- 40 to + 125	°C
	^{*3} Soldering temperature	T_{sol}	260	°C

*1 Pulse width ≤ 100μs, Duty ratio : 0.001

*2 40 to 60% RH, AC for 1 minute

*3 For 10 seconds

Electro-optical Characteristics

(Ta = 25°C)

Parameter		Symbol	Conditions	MIN.	TYP.	MAX.	Unit	
Input	Forward voltage	V_F	$I_F = 10\text{mA}$	-	1.2	1.4	V	
	Peak forward voltage	V_{FM}	$I_{FM} = 0.5\text{A}$	-	-	3	V	
	Reverse current	I_R	$V_R = 4\text{V}$	-	-	10	μA	
	Terminal capacitance	C_t	$V = 0, f = 1\text{kHz}$	-	30	250	pF	
Output	Collector dark current	I_{CEO}	$V_{CE} = 200\text{V}, I_F = 0, R_{BE} = \infty$	-	-	10^{-6}	A	
	Current transfer ratio	CTR	$I_F = 1\text{mA}, V_{CE} = 2\text{V}, R_{BE} = \infty$	1 000	4 000	15 000	%	
Transfer characteristics	Collector-emitter saturation voltage	$V_{CE(sat)}$	$I_F = 20\text{mA}, I_C = 100\text{mA}, R_{BE} = \infty$	-	-	1.2	V	
	Isolation resistance	R_{ISO}	DC500V, 40 to 60% RH	5×10^{10}	10^{11}	-	Ω	
	Floating capacitance	C_f	$V = 0, f = 1\text{MHz}$	-	0.6	1.0	pF	
	Cut-off frequency	f_c	$V_{CE} = 2\text{V}, I_C = 20\text{mA}, R_L = 100\Omega, R_{BE} = \infty, -3\text{dB}$	1	7	-	kHz	
				Response time	Rise time	t_r	$V_{CE} = 2\text{V}, I_C = 20\text{mA}$	-
		Fall time	t_f	$R_L = 100\Omega, R_{BE} = \infty$	-	20	100	μs

Fig. 1 Forward Current vs. Ambient Temperature

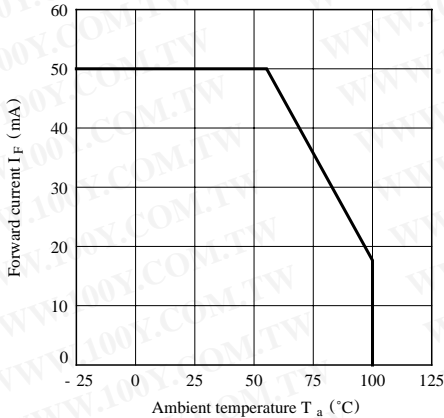

Fig. 2 Collector Power Dissipation vs. Ambient Temperature

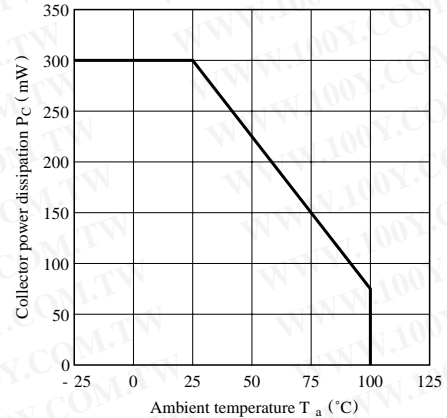

Fig. 3 Peak Forward Current vs. Duty Ratio

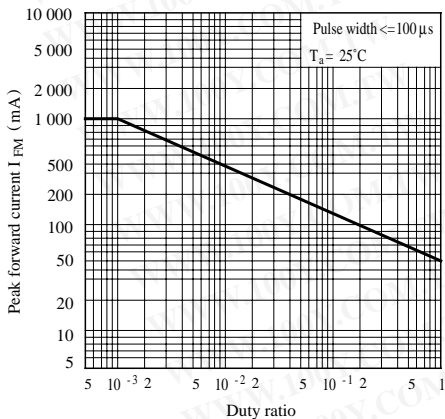

Fig. 4 Forward Current vs. Forward Voltage

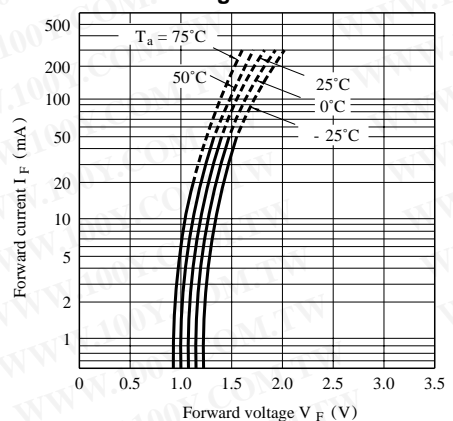

Fig. 5 Current Transfer Ratio vs. Forward Current

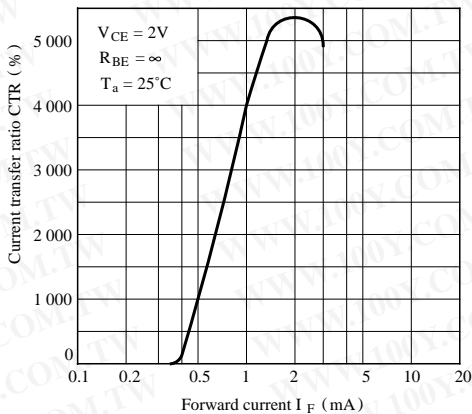

Fig. 6 Collector Current vs. Collector-emitter Voltage

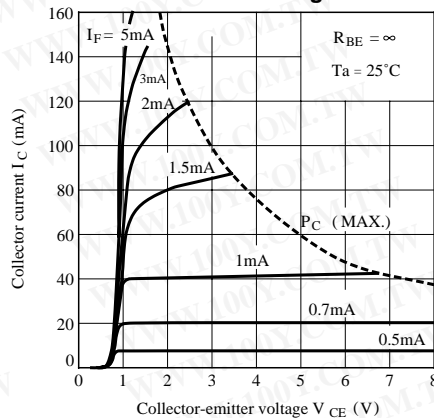

Fig. 7 Relative Current Transfer Ratio vs. Ambient Temperature

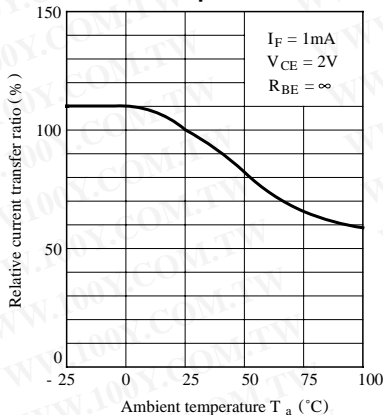

Fig. 8 Collector-emitter Saturation Voltage vs. Ambient Temperature

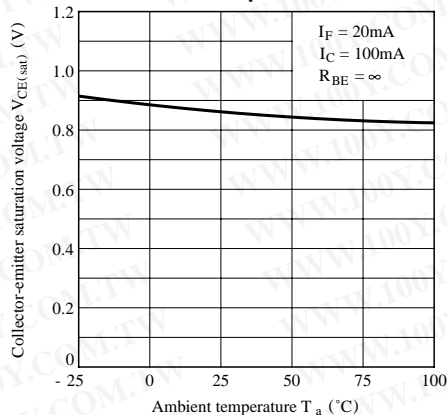

Fig. 9 Collector Dark Current vs. Ambient Temperature

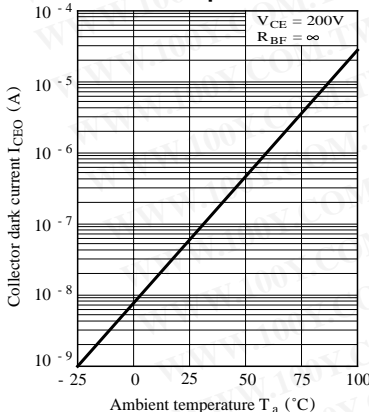
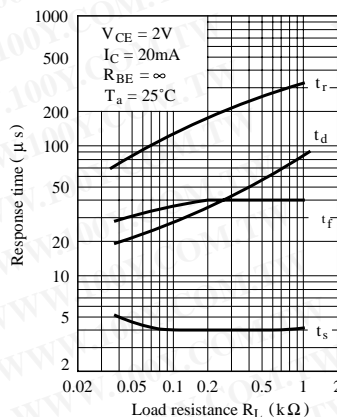

Fig.10 Response Time vs. Load Resistance



Test Circuit for Response Time

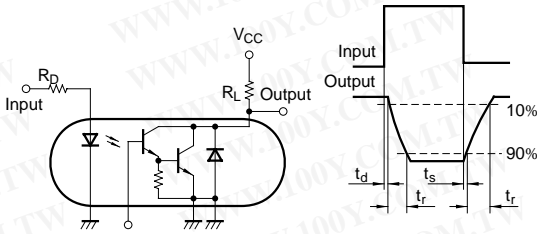
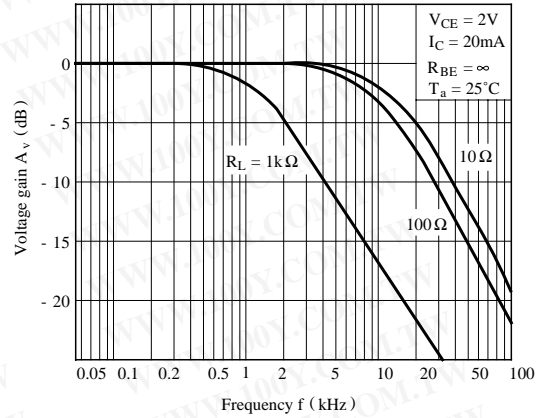
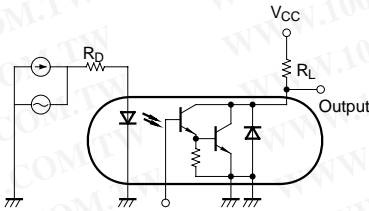

Fig.10 Frequency Response



Test Circuit for Frequency Response



勝特力材料 886-3-5753170
 勝特力电子(上海) 86-21-34970699
 勝特力电子(深圳) 86-755-83298787
[Http://www.100y.com.tw](http://www.100y.com.tw)

● Please refer to the chapter “Precautions for Use”.