

Photomicrosensor (Reflective) EE-SY193

勝特力材料 886-3-5753170
 勝特力电子(上海) 86-21-34970699
 勝特力电子(深圳) 86-755-83298787
 Http://www.100y.com.tw

■ Dimensions.

Note: All units are in millimeters unless otherwise indicated.

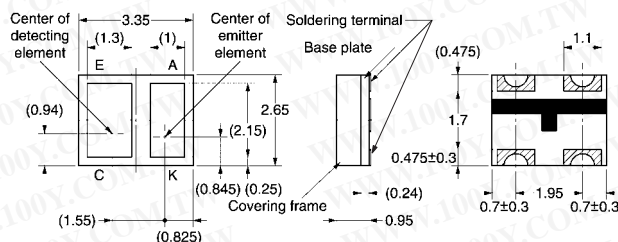

Internal Circuit

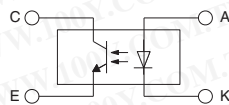

| Terminal No. | Name |
|--------------|-----------|
| A | Anode |
| K | Cathode |
| C | Collector |
| E | Emitter |

Recommended soldering patterns

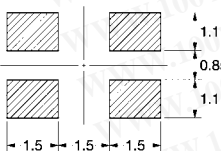

Unless otherwise specified, the tolerances are ±0.2 mm.

■ Features

- Ultra-compact model.
- PCB surface mounting type.
- RoHS Compliant.

■ Absolute Maximum Ratings (Ta = 25°C)

| Item | Symbol | Rated value |
|---------------------|---------------------------|------------------------------|
| Emitter | Forward current | I_F 25 mA (see note 1) |
| | Pulse forward current | I_{FP} 100 mA (see note 2) |
| | Reverse voltage | V_R 6 V |
| Detector | Collector–Emitter voltage | V_{CEO} 18 V |
| | Emitter–Collector voltage | V_{ECO} 4 V |
| | Collector current | I_C 20 mA |
| | Collector dissipation | P_C 75 mW (see note 1) |
| Ambient temperature | Operating | T_{opr} -30°C to 80°C |
| | Storage | T_{stg} -40°C to 85°C |
| | Reflow soldering | T_{sol} 220°C (see note 3) |
| | Manual soldering | T_{sol} 300°C (see note 3) |

Note: 1. Refer to the temperature rating chart if the ambient temperature exceeds 25°C.

2. Duty: 1/100; Pulse width: 0.1 ms

3. Complete soldering within 10 seconds for reflow soldering and within 3 seconds for manual soldering.

■ Ordering Information

| Description | Model |
|-------------------------------|----------|
| Photomicrosensor (reflective) | EE-SY193 |

■ Electrical and Optical Characteristics (Ta = 25°C)

| Item | Symbol | Value | Condition |
|--------------|--------------------------------------|--|---|
| Emitter | Forward voltage | V_F 1.1 V typ., 1.3 V max. | $I_F = 4$ mA |
| | Reverse current | I_R 10 μ A max. | $V_R = 6$ V |
| | Peak emission wavelength | λ_P 940 nm typ. | $I_F = 20$ mA |
| Detector | Light current | I_L 100 μ A min., 150 μ A typ., 360 μ A max. | Aluminum-deposited surface, $I_F = 4$ mA, $V_{CE} = 2$ V, $d = 1$ mm (see note) |
| | Dark current | I_D 100 nA max. | $V_{CE} = 10$ V, 0 lx |
| | Leakage current | I_{LEAK} 1 μ A max. | $I_F = 4$ mA, $V_{CE} = 2$ V |
| | Collector–Emitter saturated voltage | $V_{CE(sat)}$ --- | --- |
| | Peak spectral sensitivity wavelength | λ_P 900 nm typ. | --- |
| Rising time | t_r 25 μ s typ. | $V_{CC} = 2$ V, $R_L = 1$ k Ω , | |
| Falling time | t_f 30 μ s typ. | $V_{CC} = 2$ V, $R_L = 1$ k Ω , | |

Note: The letter “d” indicates the distance between the top surface of the sensor and the sensing object.

■ Engineering Data

Forward Current vs. Collector Dissipation Temperature Rating

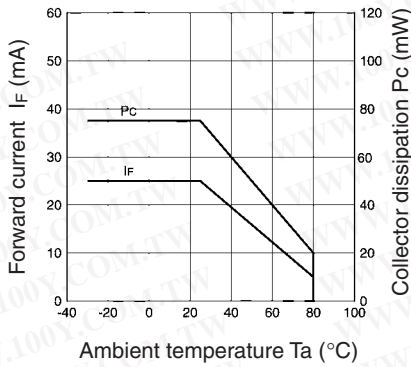

Forward Current vs. Forward Voltage Characteristics (Typical)

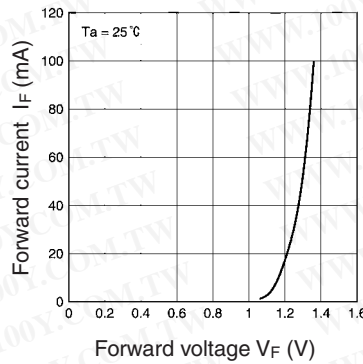

Light Current vs. Forward Current Characteristics (Typical)

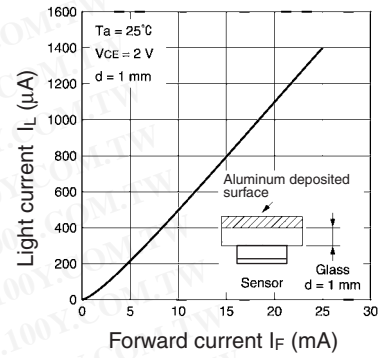

Light Current vs. Collector–Emitter Voltage Characteristics (Typical)

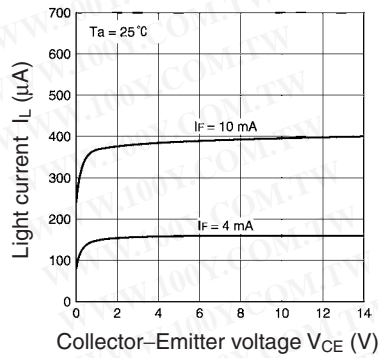

Relative Light Current vs. Ambient Temperature Characteristics (Typical)

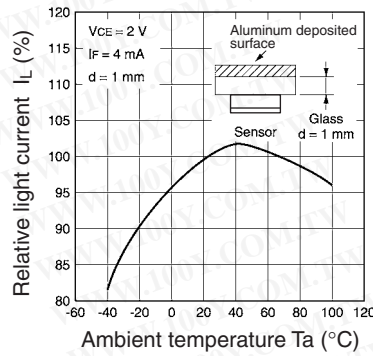

Dark Current vs. Ambient Temperature Characteristics (Typical)

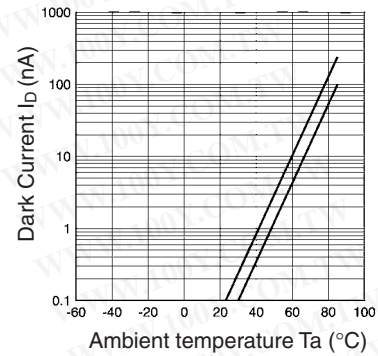

Response Time vs. Load Resistance Characteristics (Typical)

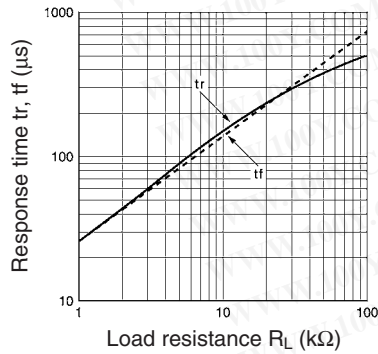

Sensing Distance Characteristics (Typical)

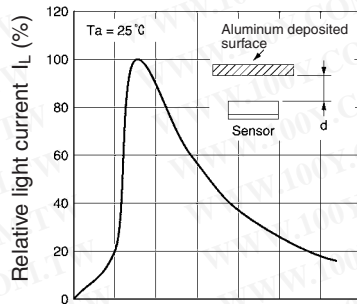

Sensing Position Characteristics (Typical)

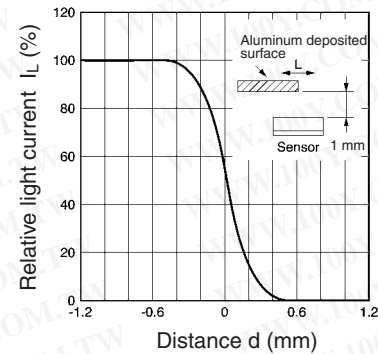

Response Time Measurement Circuit

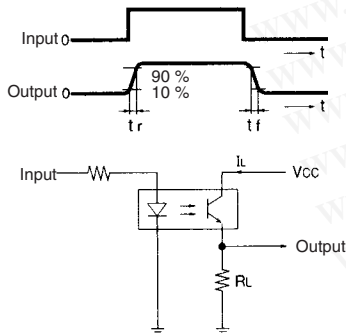

Unit: mm (inch)

■ Tape and Reel

Reel

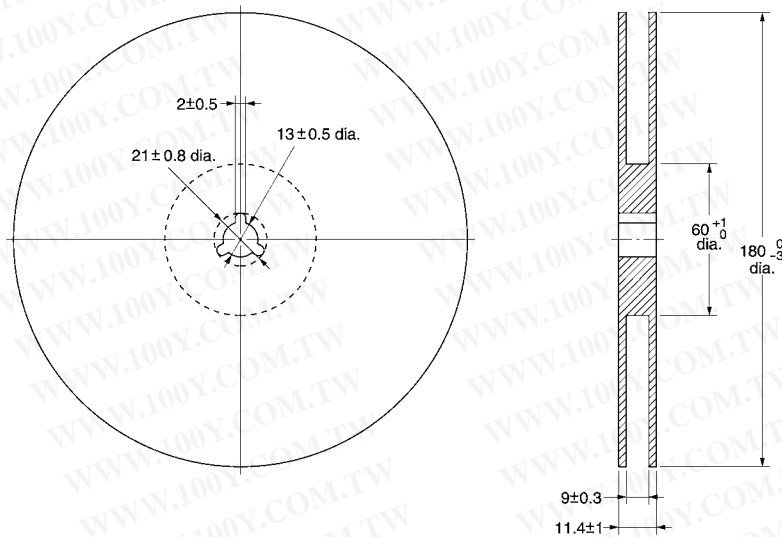

Tape

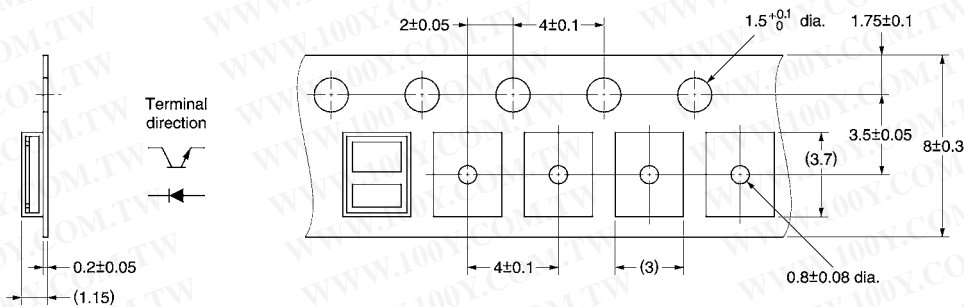

Tape configuration

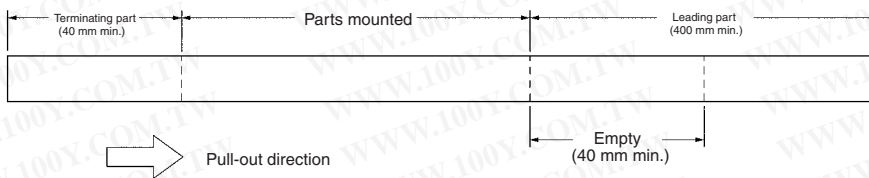

Tape quantity

3,000 pcs./reel

Precautions

■ Soldering Information

Reflow soldering

- The following soldering paste is recommended:
Melting temperature: 178 to 192°C
- The recommended thickness of the metal mask for screen printing is between 0.2 and 0.25 mm.
- Set the reflow oven so that the temperature profile shown in the following chart is obtained for the upper surface of the product being soldered.

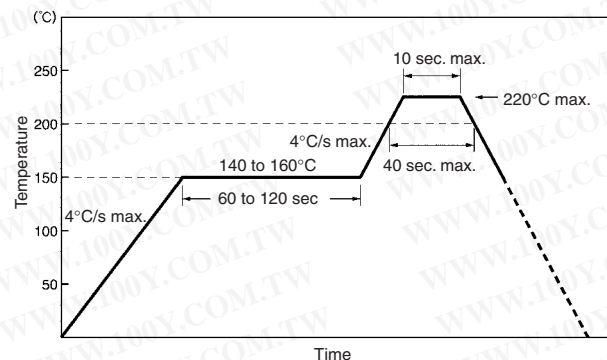

勝特力材料 886-3-5753170
 勝特力电子(上海) 86-21-34970699
 勝特力电子(深圳) 86-755-83298787
[Http://www.100y.com.tw](http://www.100y.com.tw)

Manual soldering

- Use "Sn 60" (60% tin and 40% lead) or solder with silver content.
- Use a soldering iron of less than 25 W, and keep the temperature of the iron tip at 300°C or below.
- Solder each point for a maximum of three seconds.
- After soldering, allow the product to return to room temperature before handling it.

Storage

To protect the product from the effects of humidity until the package is opened, dry-box storage is recommended. If this is not possible, store the product under the following conditions:

Temperature: 10 to 30°C

Humidity: 60% max.

The product is packed in a humidity-proof envelope. Reflow soldering must be done within 48 hours after opening the envelope, during which time the product must be stored under 30°C at 80% maximum humidity.

If it is necessary to store the product after opening the envelope, use dry-box storage or reseal the envelope.

Baking

If a product has remained packed in a humidity-proof envelope for six months or more, or if more than 48 hours have lapsed since the envelope was opened, bake the product under the following conditions before use:

Reel: 60°C for 24 hours or more

Bulk: 80°C for 24 hours or more