

勝特力材料 886-3-5753170  
 勝特力电子(上海) 86-21-34970699  
 勝特力电子(深圳) 86-755-83298787  
[Http://www.100y.com.tw](http://www.100y.com.tw)

# HOA2005

## Transmissive Optoschmitt Sensor

### FEATURES

- Direct TTL interface
- Buffer logic
- Side mount package
- Ambient light and dust protective filter
- Accurate position sensing
- 0.010 in.(0.25mm) aperture windows
- 0.125 in.(3.18 mm) slot width
- 24.0 in.(610 mm) min. 26 AWG UL 1429 wire leads

### DESCRIPTION

The HOA2005 consists of an infrared emitting diode facing an Optoschmitt detector encased in a black thermoplastic housing. The photodetector consists of a photodiode, amplifier, voltage regulator, Schmitt trigger and an NPN output transistor with 10 kΩ (nominal) pull-up resistor. The buffer logic provides a high output when the optical path is clear, and a low output when the path is blocked. The side mounting package is useful in applications in which the interruptive element is parallel to the mounting plane. Both emitter and detector have a 0.010 in.(.25 mm) x .060 in.(1.52 mm) vertical aperture. This feature is ideal for use in applications in which maximum position resolution is desired.

All devices employ a built-in strain relief for maximum wire attachment strength. The sensor housing contains IR transmissive optical windows. This arrangement provides excellent protection against ambient light while eliminating aperture openings which could be clogged by airborne contaminants. The HOA2005 series employs plastic molded components. For additional component information see SEP8506, and SDP8600.

Housing material is polycarbonate. Housings are soluble in chlorinated hydrocarbons and ketones. Recommended cleaning agents are methanol and isopropanol.

Wire color and functions are:

- Red - IRED Anode
- Black - IRED Cathode
- Green - Detector Ground
- White - Detector Vcc
- Blue - Detector Output



INFRA-90.TIF

### OUTLINE DIMENSIONS in inches (mm)

Tolerance	3 plc decimals	±0.005(0.12)
	2 plc decimals	±0.020(0.51)

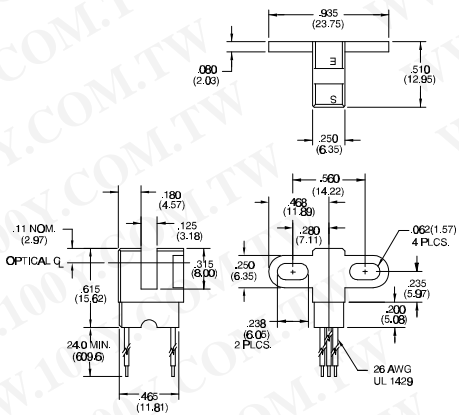

DIM\_063.cdr

# HOA2005

## Transmissive Optoschmitt Sensor

### ELECTRICAL CHARACTERISTICS (25°C unless otherwise noted)

PARAMETER	SYMBOL	MIN	TYP	MAX	UNITS	TEST CONDITIONS
<b>IR EMITTER</b>						
Forward Voltage	$V_F$			1.6	V	$I_F=20\text{ mA}$
Reverse Leakage Current	$I_R$			10	$\mu\text{A}$	$V_R=3\text{ V}$
<b>DETECTOR</b>						
Operating Supply Voltage	$V_{CC}$	4.5		12	V	
Low Level Supply Current	$I_{CC(L)}$	4.0		12	mA	$V_{CC}=5\text{ V}$ $V_{CC}=12\text{ V}$
High Level Supply Current	$I_{CC(H)}$	2.0		10	mA	$V_{CC}=5\text{ V}$ $V_{CC}=12\text{ V}$
Low Level Output Voltage	$V_{OL}$			0.4	V	$I_{OL}=12.8\text{ mA}$ , $I_F=0\text{ mA}$
High Level Output Voltage	$V_{OH}$	2.4			V	$I_{OH}=0$ , $I_F=20\text{ mA}$
Hysteresis <sup>(2)</sup>	HYST		10		%	
Propagation Delay, Low-High, High-Low	$t_{PLH}$ , $t_{PHL}$		5		$\mu\text{s}$	$V_{CC}=5\text{ V}$ , $I_F=20\text{ mA}$
Rise Time	$t_r$		60		ns	$R_L=390\ \Omega$ , $C_L=50\text{ pF}$
Fall Time	$t_f$		6		ns	$R_L=390\ \Omega$ , $C_L=50\text{ pF}$
<b>COUPLED CHARACTERISTICS</b>						
IRED Trigger Current HOA2005-001	$I_{FT}$			20	mA	$V_{CC}=5\text{ V}$

#### Notes

- It is recommended that a bypass capacitor, 0.1  $\mu\text{F}$  typical, be added between  $V_{CC}$  and GND near the device in order to stabilize power supply line.
- Hysteresis is defined as the difference between the operating and release threshold intensities, expressed as a percentage of the operate threshold intensity.

### ABSOLUTE MAXIMUM RATINGS

(25°C Free-Air Temperature unless otherwise noted)

Operating Temperature Range	-40°C to 70°C
Storage Temperature Range	-40°C to 85°C
Soldering Temperature (5 sec)	240°C

#### IR EMITTER

Power Dissipation	100 mW <sup>(1)</sup>
Reverse Voltage	3 V
Continuous Forward Current	50 mA

#### DETECTOR

Supply Voltage	12 V <sup>(2)</sup>
Output Sink Current	18 mA
Duration of Output Short to $V_{CC}$ or Ground	1.0 sec

### SCHEMATIC

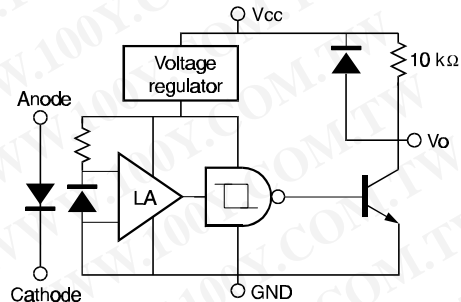

Honeywell reserves the right to make changes in order to improve design and supply the best products possible.

# Honeywell

# HOA2005

## Transmissive Optoschmitt Sensor

SWITCHING WAVEFORM

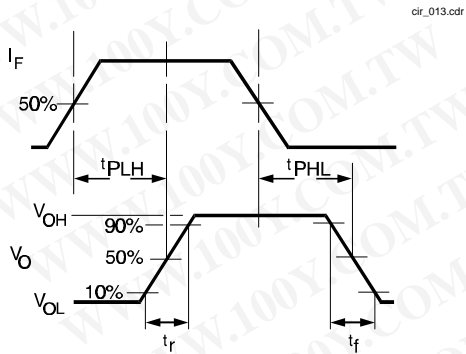

Fig. 1 SWITCHING WAVEFORM

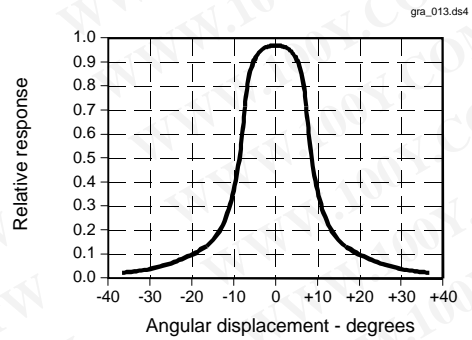

Fig. 2 IRED Forward Bias Characteristics

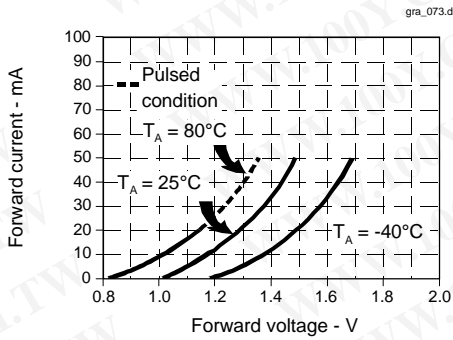
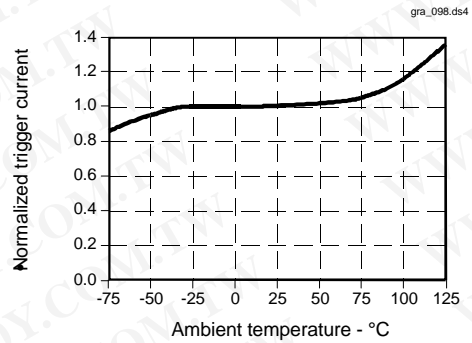

Fig. 3 IRED Trigger Current vs Temperature



All Performance Curves Show Typical Values

# HOA2005

Transmissive Optoschnitt Sensor

Honeywell reserves the right to make changes in order to improve design and supply the best products possible.

**Honeywell**

375