

Si PIN photodiodes



S3096-02

S4204

Dual-element, plastic package photodiode

The S3096-02 and S4204 are dual-element Si PIN photodiodes molded into plastic packages. Having high sensitivity and low noise, these photodiodes have low crosstalk between the elements. Custom devices (with different element shapes, number of elements, characteristics and packages) are also available to meet your specific needs. Please feel free to contact our sales office.

Features

- High sensitivity
- Uniform element sensitivity
- Low crosstalk
- Low noise

Applications

- Optical switch
- Various position detection applications

勝特力材料 886-3-5753170
 勝特力电子(上海) 86-21-54151736
 勝特力电子(深圳) 86-755-83298787
[Http://www.100y.com.tw](http://www.100y.com.tw)

General ratings / Absolute maximum ratings

Parameter	Symbol	S3096-02	S4204	Unit
Active area	-	1.2 × 3 / 2 elements	1 × 2 / 2 elements	mm
Element gap	-	30	20	μm
Reverse voltage	V _R Max.	20		V
Operating temperature	T _{opr}	-25 to +85		°C
Storage temperature	T _{stg}	-40 to +100		°C

Electrical and optical characteristics (Typ. T_a=25 °C, unless otherwise noted, per 1 element)

Parameter	Symbol	Condition	S3096-02			S4204			Unit
			Min.	Typ.	Max.	Min.	Typ.	Max.	
Spectral response range	λ		-	320 to 1100	-	-	320 to 1100	-	nm
Peak sensitivity wavelength	λ _p		-	960	-	-	960	-	nm
Photo sensitivity	S	λ=λ _p	-	0.58	-	-	0.65	-	A/W
Dark current	I _D	V _R =10 V, all elements	-	0.05	0.5	-	0.1	1.0	nA
Temp. coefficient of I _D	T _{CID}		-	1.15	-	-	1.15	-	times/°C
Cut-off frequency	f _c	V _R =10 V, R _L =50 Ω λ=780 nm, -3 dB	-	25	-	-	30	-	MHz
Terminal capacitance	C _t	V _R =10 V, f=1 MHz	-	5	-	-	3	-	pF
Noise equivalent power	NEP	V _R =10 V	-	7.2 × 10 ⁻¹⁵	-	-	8.7 × 10 ⁻¹⁵	-	W/Hz ^{1/2}

Spectral response

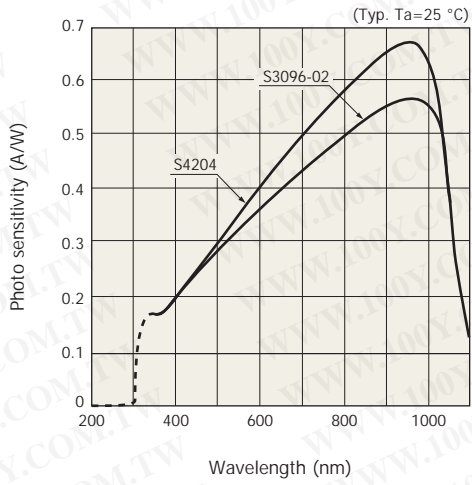

KMPDB0134EC

Photo sensitivity temperature characteristic

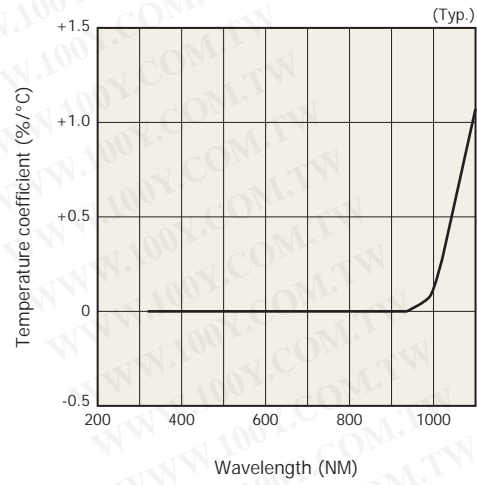

KMPDB0135ED

Dark current vs. reverse voltage

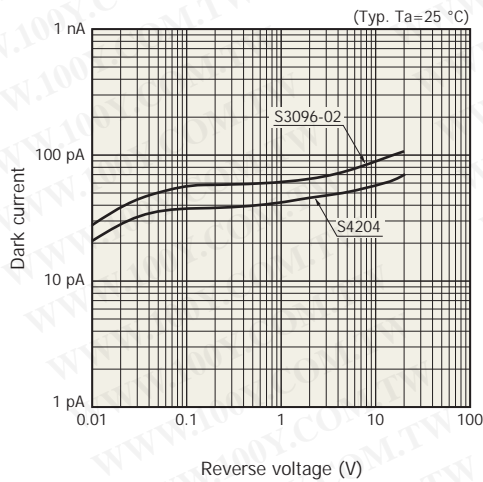

KMPDB0136EC

Terminal capacitance vs. reverse voltage

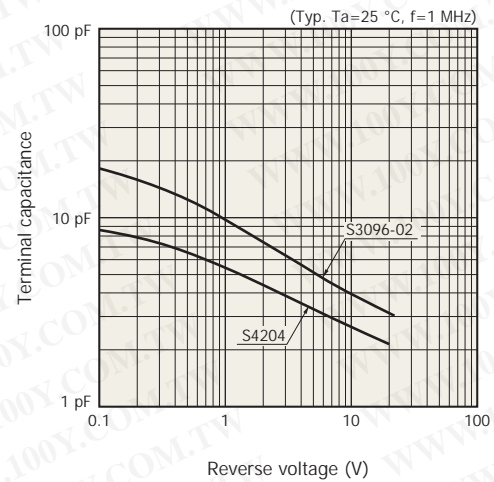

KMPDB0137EC

Dimensional outlines (unit: mm, tolerance unless otherwise noted: ± 0.1)

S3096-02

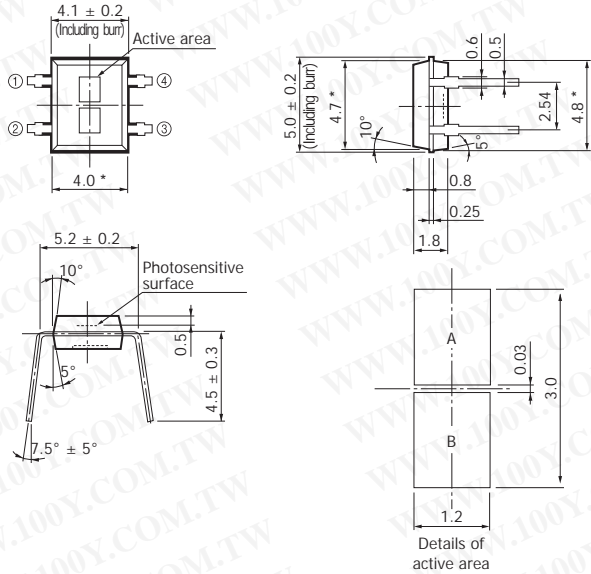

- ① Anode A
- ② Cathode common
- ③ Anode B
- ④ Cathode common

Chip position accuracy with respect to the package dimensions marked *
 X, Y ± 0.2
 $\theta \pm 2^\circ$

Lead surface finish: Silver plating
 Packing: Stick (50 pcs/stick)

KMPDA0119EB

S4204

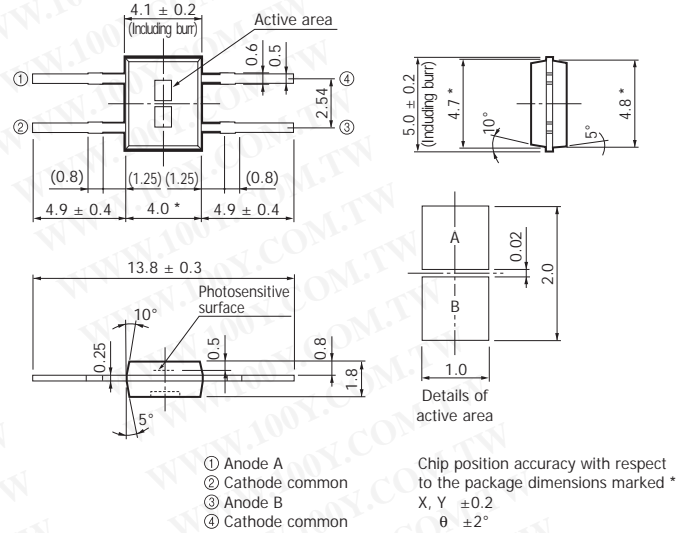

- ① Anode A
- ② Cathode common
- ③ Anode B
- ④ Cathode common

Chip position accuracy with respect to the package dimensions marked *
 X, Y ± 0.2
 $\theta \pm 2^\circ$

Lead surface finish: Silver plating
 Packing: Stick (50 pcs/stick)

KMPDA0120EB

Information furnished by HAMAMATSU is believed to be reliable. However, no responsibility is assumed for possible inaccuracies or omissions. Specifications are subject to change without notice. No patent rights are granted to any of the circuits described herein. ©2008 Hamamatsu Photonics K.K.

HAMAMATSU

www.hamamatsu.com

HAMAMATSU PHOTONICS K.K., Solid State Division

1126-1 Ichino-cho, Higashi-ku, Hamamatsu City, 435-8558 Japan, Telephone: (81) 53-434-3311, Fax: (81) 53-434-5184

U.S.A.: Hamamatsu Corporation: 360 Foothill Road, P.O.Box 6910, Bridgewater, N.J. 08807-0910, U.S.A., Telephone: (1) 908-231-0960, Fax: (1) 908-231-1218

Germany: Hamamatsu Photonics Deutschland GmbH: Arzbergerstr. 10, D-82211 Herrsching am Ammersee, Germany, Telephone: (49) 08152-3750, Fax: (49) 08152-2658

France: Hamamatsu Photonics France S.A.R.L.: 19, Rue du Saule Trapu, Parc du Moulin de Massy, 91882 Massy Cedex, France, Telephone: 33-(1) 69 53 71 00, Fax: 33-(1) 69 53 71 10

United Kingdom: Hamamatsu Photonics UK Limited: 2 Howard Court, 10 Tewin Road, Welwyn Garden City, Hertfordshire AL7 1BW, United Kingdom, Telephone: (44) 1707-294888, Fax: (44) 1707-325777

North Europe: Hamamatsu Photonics Norden AB: Smidesvägen 12, SE-171 41 Solna, Sweden, Telephone: (46) 8-509-031-00, Fax: (46) 8-509-031-01

Italy: Hamamatsu Photonics Italia S.R.L.: Strada della Moia, 1/E, 20020 Arese, (Milano), Italy, Telephone: (39) 02-935-81-733, Fax: (39) 02-935-81-741