

■ Features:

1. Low power consumption
2. High efficiency
3. Reliable and rugged
4. Chip Material: AlGaInP
5. Lens Color: Water Clear
6. Source Color: Blue

勝特力材料 886-3-5753170
勝特力电子(上海) 86-21-34970699
勝特力电子(深圳) 86-755-83298787
Http://www.100y.com.tw

■ Outline Dimensions:

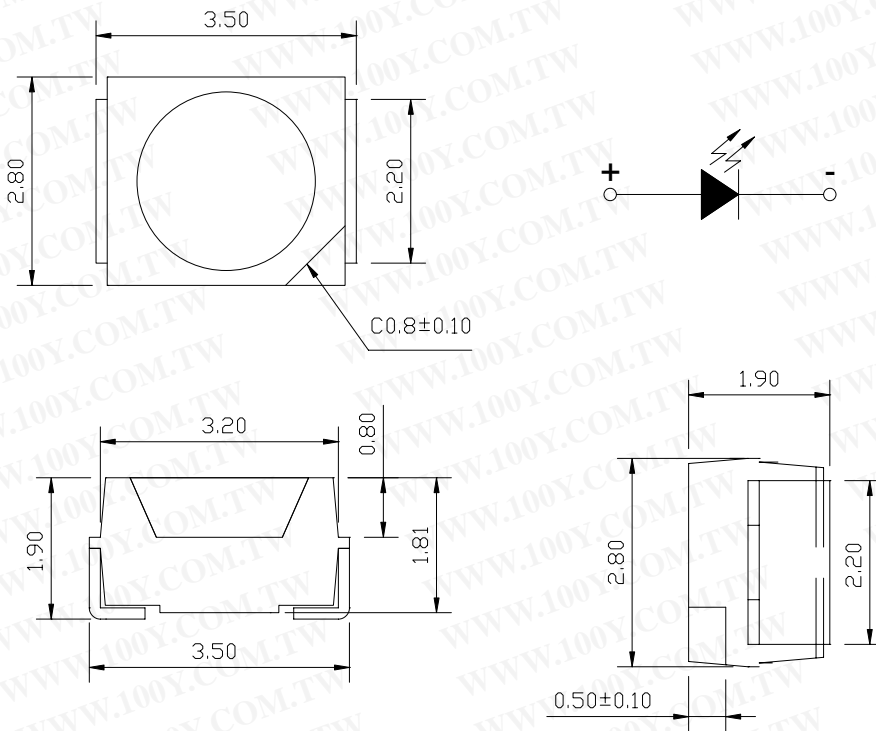

Note :

1. All dimensions are in millimeters (inches)
2. Tolerance is ± 0.25 mm (.010") unless otherwise noted
3. Protruded resin under flange is 1.0mm (.04") max.
4. Lead spacing is measured where the leads emerge from the package.
5. Specifications are subject to change without notices.

■ **Absolute Maximum Ratings at Ta=25°C:**

Parameter	Maximum	Unit
Power Dissipation	120	mW
Peak Forward Current (1/10 Duty Cycle,0.1ms Pulse Width)	100	mA
Continuous Forward Current	30	mA
Derating Linear From 50°C	0.5	mA/°C
Reverse Voltage	5	V
Operating Temperature Range	-40°C to +100°C	
Storage Temperature Range	-40°C to +100°C	
Lead Soldering Temperature [4mm(0.175") from body]	260°C for 5 Seconds	

■ **Electrical/Optical Characteristics at Ta=25°C:**

Parameter	Symbol	Test Condition	Min.	Typ.	Max.	Unit
Luminous Intensity	I_v	$I_F=20mA$	250	350	500	mcd
Viewing Angle	$2\theta_{1/2}$	$I_F=20mA$		120		deg
Forward Voltage	V_F	$I_F=20mA$	2.7	3.2	3.7	V
Reverse Current	I_R	$V_R=5V$	-	-	10	uA
Dominant Wavelength	λ_d	$I_F=20mA$	465	-	475	nm

■ Typical Electrical/Optical Characteristics Curve: (25°C Ambient Temperature Unless Otherwise Noted)

Relative Luminous Intensity vs Forward Current, $T_{Ambient}=25^{\circ}C$

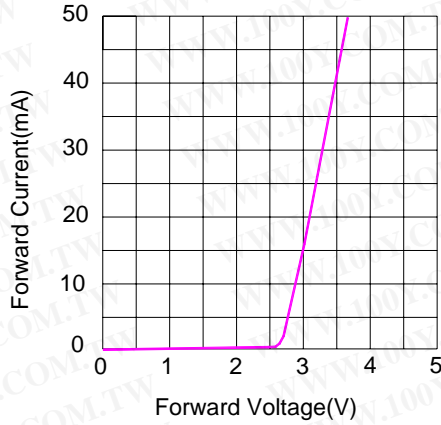

Relative Luminous Intensity vs Forward Current, $T_{Ambient}=25^{\circ}C$

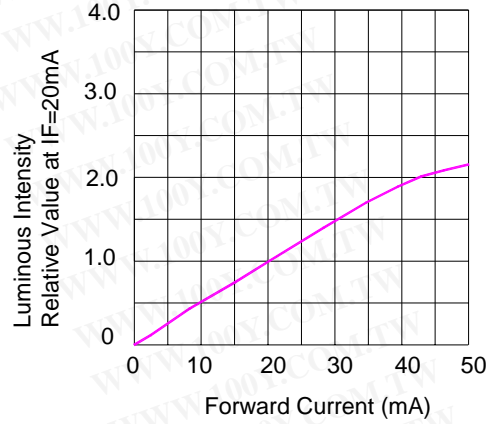

Forward Current Derating Curve, Derating based on $T_{jMAX}=85^{\circ}C$

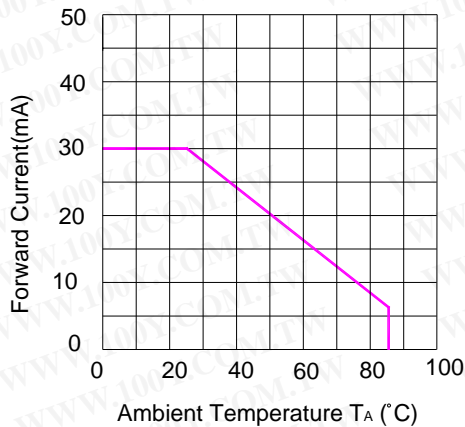

Luminous Intensity VS Ambient Temperature

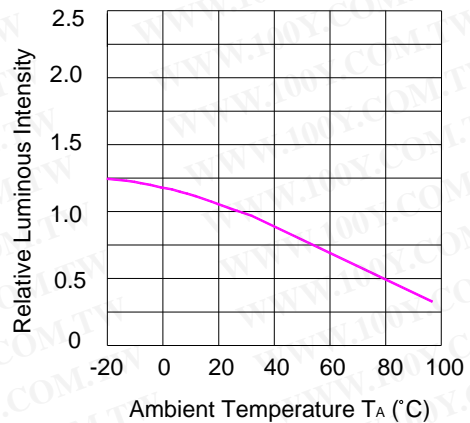

Relative Spectral Distribution, $I_F=20mA, T_{Ambient}=25^{\circ}C$

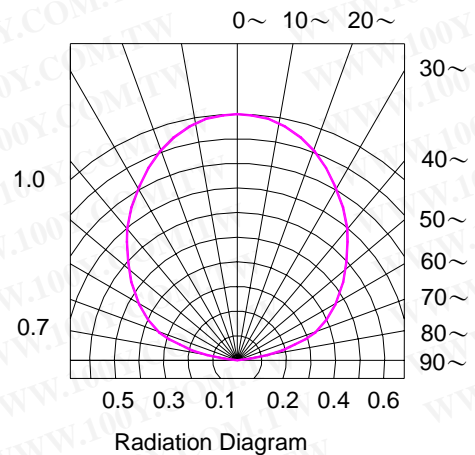
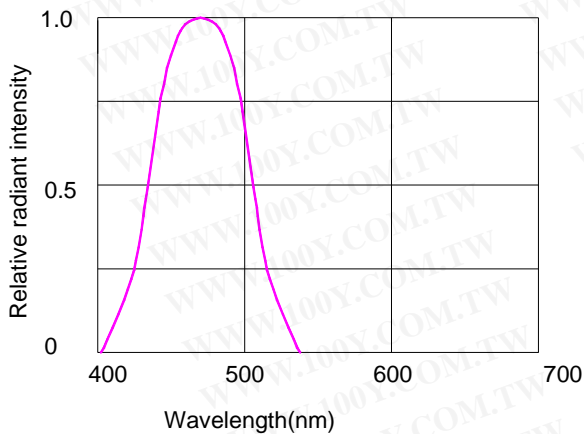

Soldering condition

Reflow Soldering			Hand Soldering	
	Lead Solder	Lead – free Solder		
Pre-heat	120~150°C	180~200°C	Temperature	350°C Max.
Pre-heat time	120sec. Max.	120sec. Max.	Soldering time	3sec. Max. (one time only)
Peak temperature	240°C Max.	260°C Max.		
Soldering time	10sec. Max.	10sec. Max.		
Condition	refer to Temperature- Profile 1	refer to Temperature- Profile 2		

Temperature profile in re-flow machine for lead type and lead free type

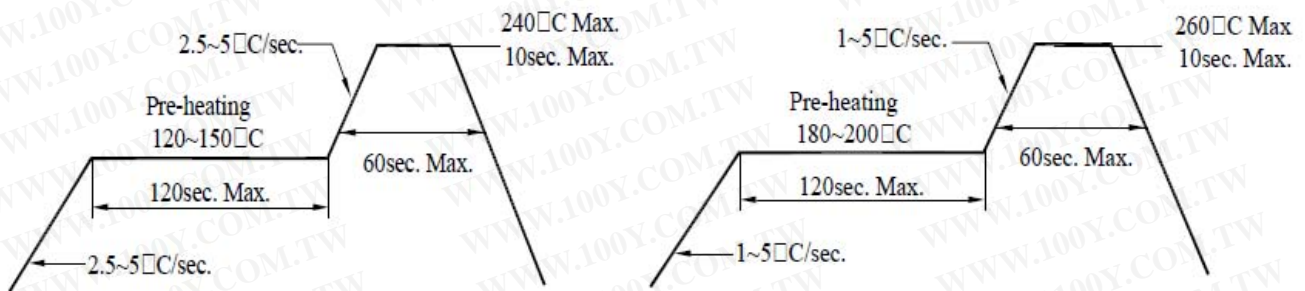

Dimension of carrier tape

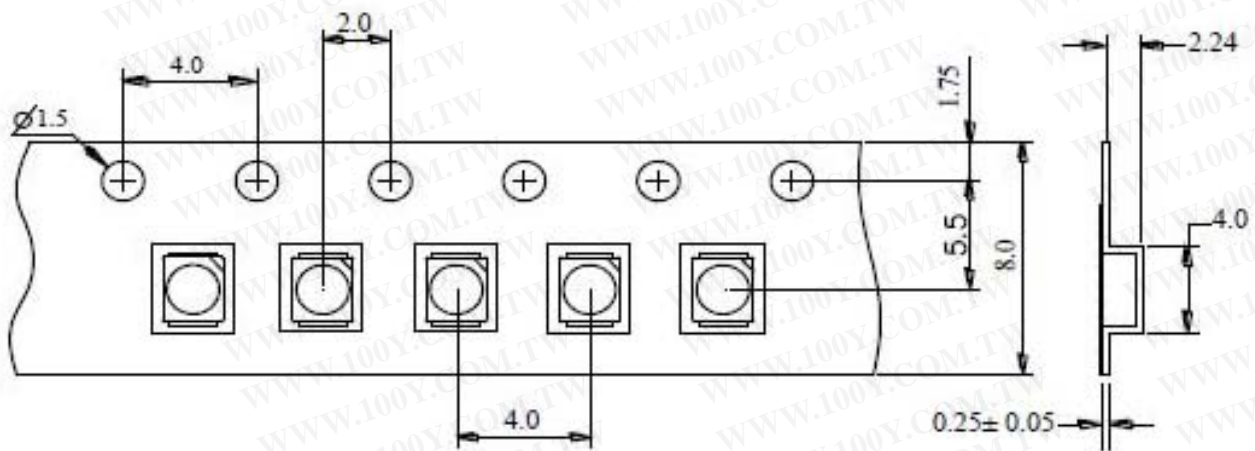

勝特力材料 886-3-5753170
勝特力电子(上海) 86-21-34970699
勝特力电子(深圳) 86-755-83298787
[Http://www.100y.com.tw](http://www.100y.com.tw)

Dimension of reel

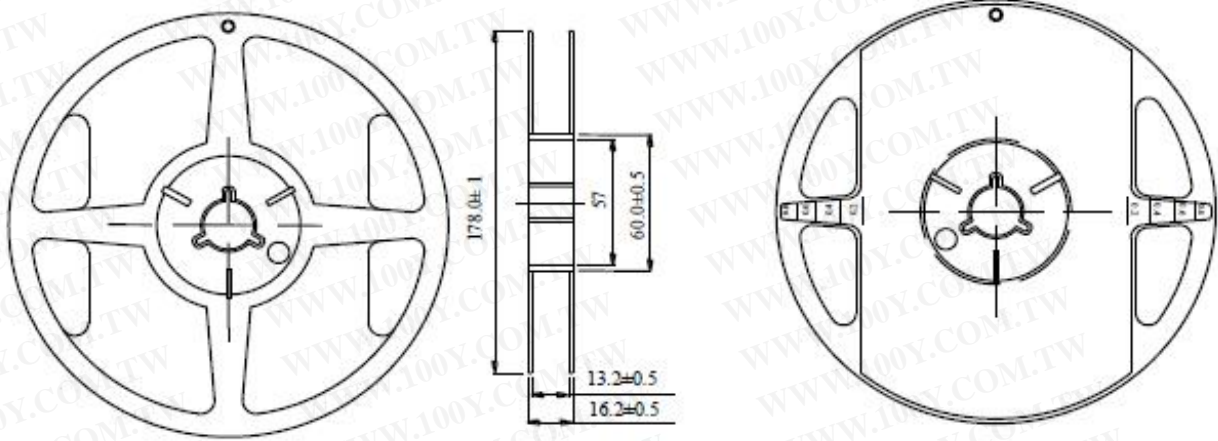

Notes:

1. All dimensions are in mm, tolerance is $\pm 2.0\text{mm}$ unless otherwise noted.
2. Specifications are subject to change without notice.

Packing

1. 2000 piece of SMD 3528 Products on one reel. The reel will be put in the anti-static bag, then sealed.
2. 2000 piece of SMD 3528 products on one bag.