

产品规格书

The product specification

客 户 CUSTOMER _____
样品编号 SPEC NO _____ BY-1026
产品型号 PART NO _____ 3RS4VCS
客户料号 PART NO _____
产品规格 MODEL _____ 3mm 圆头紫光无色透明
日 期 DATE _____

胜特力材料 886-3-5753170
胜特力电子(上海) 86-21-34970699
胜特力电子(深圳) 86-755-83298787
[Http://www.100y.com.tw](http://www.100y.com.tw)

尺寸图:

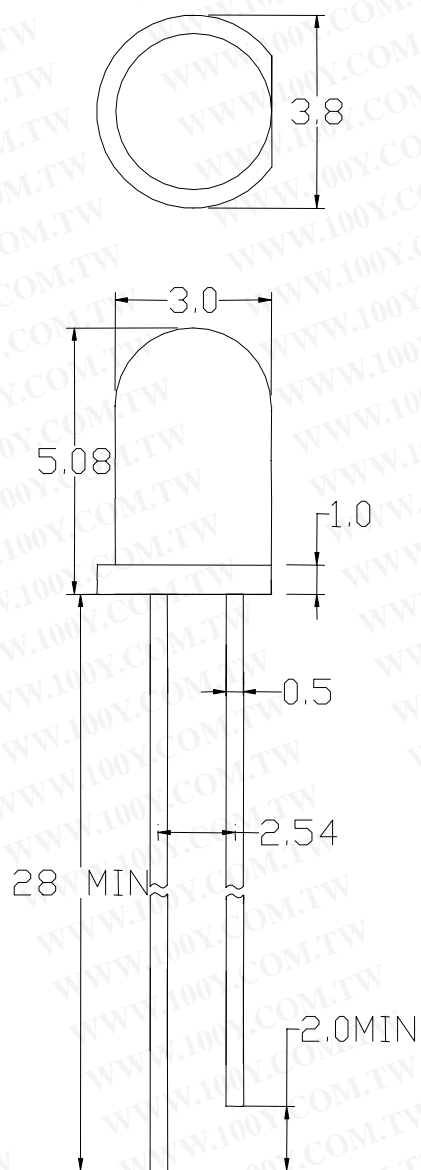

Item	Materials
Resin	Epoxy
Lens Color	Colorless
Lead Frame	Ag plating ironwork Alloy
Dice	AlGaInP

SPECIFICATION

Absolute Maximum Rating ($T_a = 25^\circ\text{C}$)

Items	Symbol	Absolute maximum Rating	Unit
Forward Current	I_F	30	mA
Peak Forward Current *	I_{FP}	100	mA
Reverse Voltage	V_R	5	V
Power Dissipation	P_D	120	mW
Electyostatic discharge	ESD	2000	V
Operation Temperature	T_{opr}	-30 ~ +85	$^\circ\text{C}$
Storage Temperature	T_{stg}	-40 ~ +100	$^\circ\text{C}$
Lead Soldering Temperature *	T_{sol}	Max 260 $^\circ\text{C}$ for 5 sec Max	

* I_{FP} Conditions: Pulse Width $\leq 10\text{msec}$

* T_{sol} Conditions: 3mm from the base of the epoxy bulb

Initial Electrical/Optical Characteristics ($T_a=25^\circ\text{C}$)

项目	符号	条件值	Min.	Typ.	Max.	Unit
顺向电压	V_F	$I_F = 20\text{mA}$	3.0	---	4.0	V
反向电流	I_R	$V_R = 5\text{V}$	---	---	10	μA
波长	λ_d	$I_F=20\text{mA}$	390	400	410	nm
亮度	I_v	$I_F=20\text{mA}$	100	-----	200	mcd
视角	$2\theta \frac{1}{2}$	$I_F=20\text{mA}$	---	30	---	deg

Notes:

*One normal delivery will include all ranks listed above.

The quantity ratio of the ranks is decided by LaiSuo

Measurement Uncertainty of the Luminous intensity : $\pm 15\%$

Measurement Uncertainty of the Dominant Wavelength : $\pm 1.0\text{nm}$

RELIABILITY

Test Items And Results

Type	Test Item	REF. Standard	Test Condition	Note	Number of Damaged
Environmental Sequence	Temperature Cycle	JIS C 7021 (1977)A-4	-40°C ⇒ 25°C ⇒ 100°C ⇒ 25°C 30mins, 5mins, 30mins, 5mins	100 cycles	0 / 100
	Thermal Shock	MIL-STD-107D	-40°C ⇒ 100°C 15mins, 15mins	100 cycles	0 / 100
	High Humidity Heat Cycle	JIS C 7021 (1977)A-5	30°C ⇒ 65°C 90%RH 24hrs/1cycle	10 cycles	0 / 100
	High Temperature Storage	JIS C 7021 (1977)B-10	T _a = 100°C	1000hrs	0 / 100
	Humidity Heat Storage	JIS C 7021 (1977)B-11	T _a = 60°C RH = 90%	1000hrs	0 / 100
	Low Temperature Storage	JIS C 7021 (1977)B-12	T _a = -40°C	1000hrs	0 / 100
Operation Sequence	Life Test	JIS C 7035 (1985)	T _a = 25°C I _F = 30mA	1000hrs	0 / 100
	High Humidity Heat Life Test	*	60°C RH=90% I _F = 20mA	500hrs	0 / 100
	Low Temperature Life Test	*	T _a = -40°C I _F = 20mA	1000hrs	0 / 100
Destructive Sequence	Resistance to Soldering Heat	JIS C 7021 (1977)A-11	T _{sol} = 260±5°C , 10sec (3mm from the base of the epoxy bulb)	1 time	0 / 20
	Solderability	JIS C 7021 (1977)A-2	T _{sol} = 235±5°C , 5sec (using flux)	1 time (over 95%)	0 / 20
	Lead Pull/Bend Test	JIS C 7021 (1977)A-11	Load 2.5N (0.25kgf) 0° ⇒ 90° ⇒ 0° bend 3 times	No noticeable damage	0 / 20

*Refer to reliability test standard specification for in this line.

