

勝特力材料 886-3-5753170  
勝特力电子(上海) 86-21-34970699  
勝特力电子(深圳) 86-755-83298787  
[Http://www.100y.com.tw](http://www.100y.com.tw)

**HAMAMATSU**  
PHOTON IS OUR BUSINESS

# SUPER-QUIET XENON FLASH LAMP Series



Compact 5 W Module type  
HQ (High Quality) Type  
SQ (Super Quiet) Type  
High Power Type with Built-in Reflector  
60 W Type  
Lamp Modules

Trigger Sockets  
Power Supplies  
Shield Box  
Cooling Jacket  
Light Guides  
Main discharge capacitor

### Medical analysis, environmental analysis

Example: Blood analyzer

#### XENON FLASH LAMP

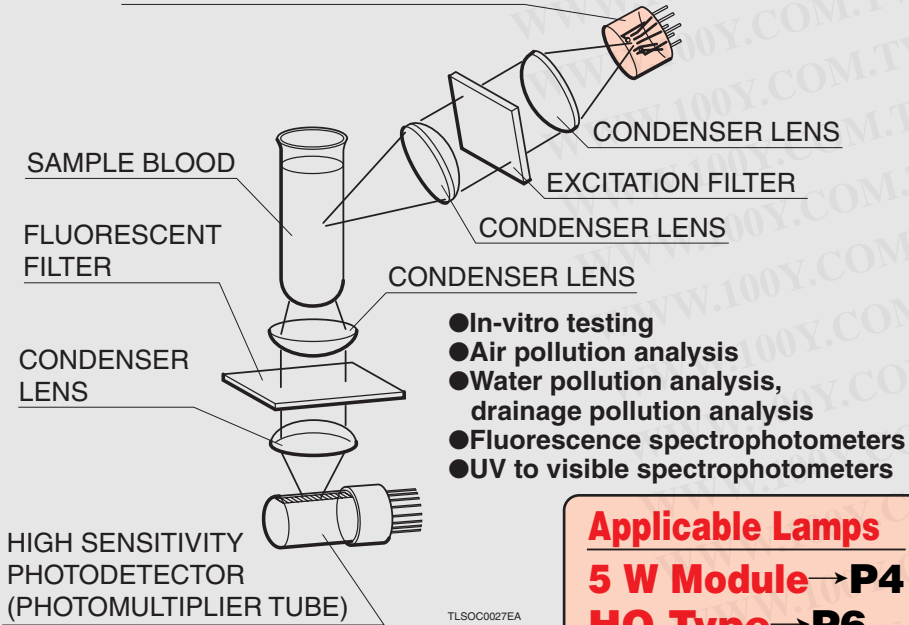

- In-vitro testing
- Air pollution analysis
- Water pollution analysis, drainage pollution analysis
- Fluorescence spectrophotometers
- UV to visible spectrophotometers

**Applicable Lamps**  
**5 W Module** → P4  
**HQ Type** → P6  
**SQ Type** → P8

### Biological research

Example: Microplate reader

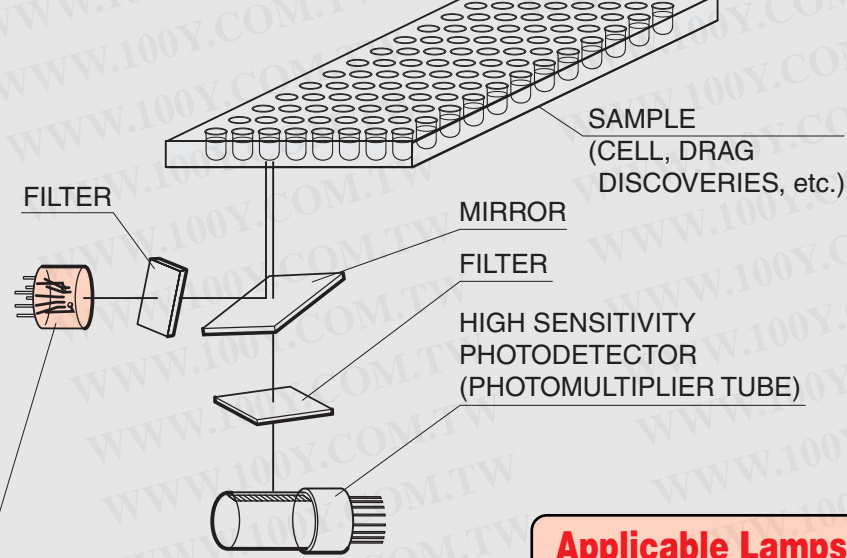

**Applicable Lamps**  
**5 W Module** → P4  
**HQ Type** → P6  
**SQ Type** → P8

### FA (Factory Automation)

Example: Strobe light for high-speed image processing

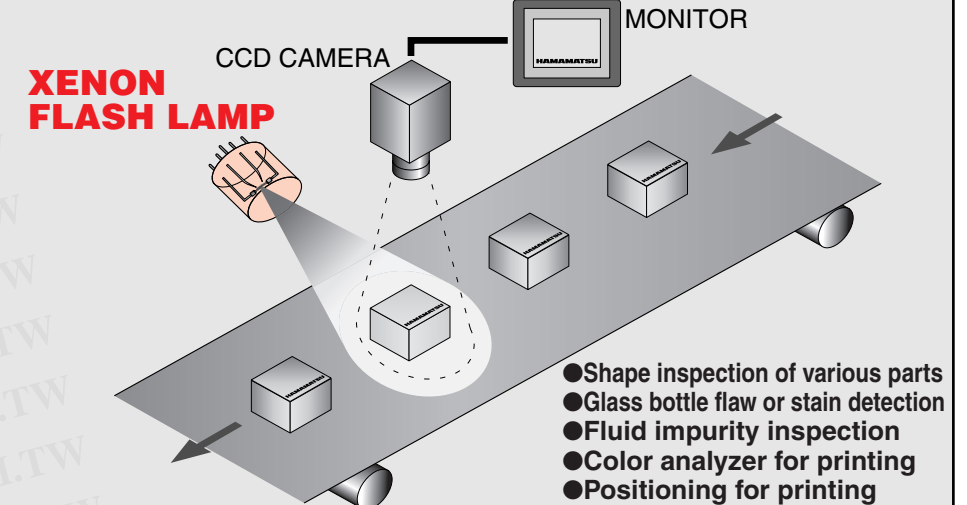

**Applicable Lamps**  
**SQ Type** → P8  
**Built-in Reflector High Output Type** → P10  
**60 W Type** → P12

### Selection Guide

What is your application?	Is high stability required?	Is a large amount of light required?	Lamp Type	Trigger Socket	Power Supply (See Page 14)	Other Accessories
Chemical analysis Medical analysis	No	No	5 W Module See Page 4	include	include	—
			HQ Type [10 W] See Page 6	E2418, E2442, E6186, E6188	C5398, C5728	Lamp Module C5604, C5605
	Yes	No	SQ Type [10 W/15 W] See Page 8	E2418, E2191, E2191-01, E2446, etc.	C5398, C5728	Shield Box E2608
			Built-in Reflector High Output Type [15 W] See Page 10	E4370-01	C10979, C10980-10	Shield Box E2608, Light Guide A2873, A7432
FA (Factory Automation)	Extremely High	Yes	60 W Type See Page 12	E6647	C6096	Cooling Jacket E6611, Main Discharge Capacitor E7289-01, Light Guide A2873, A7432

\* Please consult us for details on how to select the right.

**Recommended purchase set** This purchase set takes "high cost performance" into account.



### Xenon Flash Lamp's Features

★ Instantaneously high peak output

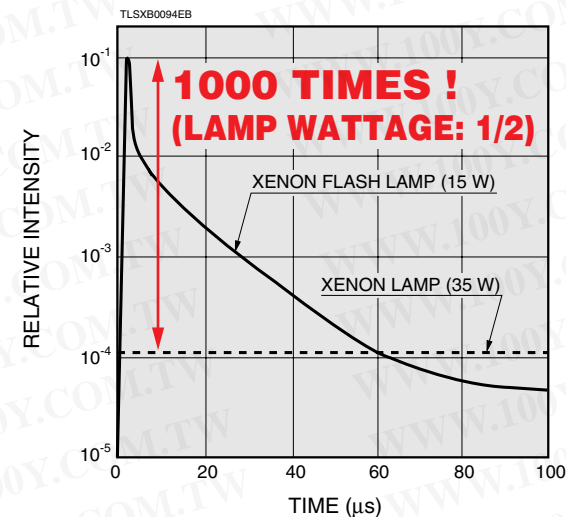

★ High-intensity, continuous line spectra from UV to IR

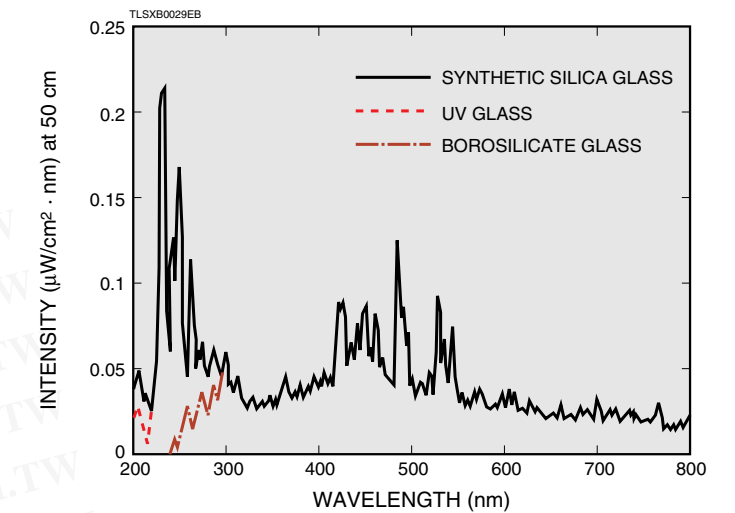

★ High stability; Fluctuation (p-p): 1.0 % Typ. (See page 6.)

★ Long service life: 1.2 × 10<sup>9</sup> flashes (See page 8.)

### Other features

- Less heat buildup : Minimal thermal damage to samples
- No warm-up required
- Color temperature: 15000 K
- Compact size
- Point light source (1.5 mm gap type)

Chemical analysis

Biological research

**COMPACT  
5 W  
MODULE**

**[ 5 W ]**

# Compact, easy handling, high repetition rate

The L9455 and L9456 are compact xenon flash lamp modules integrating a 5-watt xenon flash lamp with its power supply and trigger socket. These lamp modules allow an energy input up to 5 watts, which is the maximum among similar lamp modules of the same size. The high stability and long operating life make them ideal as light sources for water quality analyzers and atmospheric analyzers. Please select the appropriate unit for the usage from side-on type such as L9455 and L9456 or head-on type of L11035 and L11036. SMA fiber adapter type is also available.



## Long life & high stability

### Life (L9455-01)

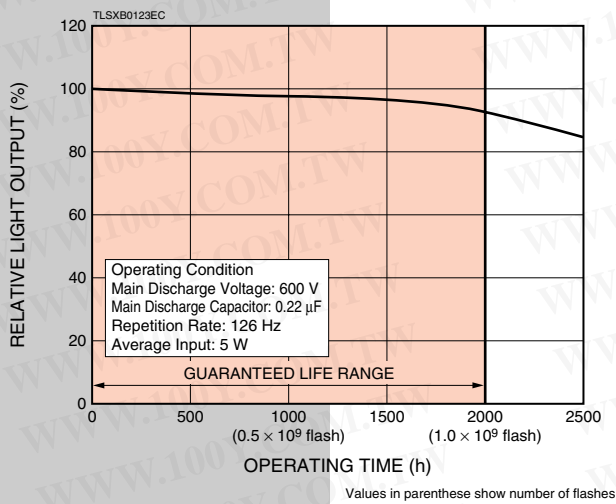

### Light Output Stability\*

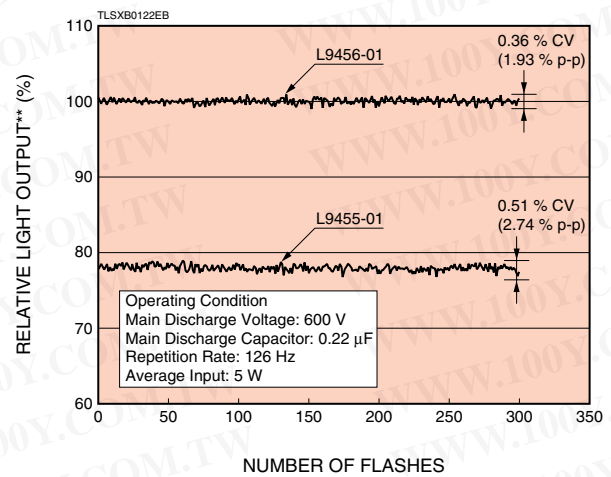

\* Calculated by: standard deviation / average light output  $\times$  100 [%]  
Calculated by: (maximum light output - minimum light output) / average light output  $\times$  100 [%]  
\*\* The light output when making the average light output of L9456-01 into 100%

### Flash Pulse Waveform

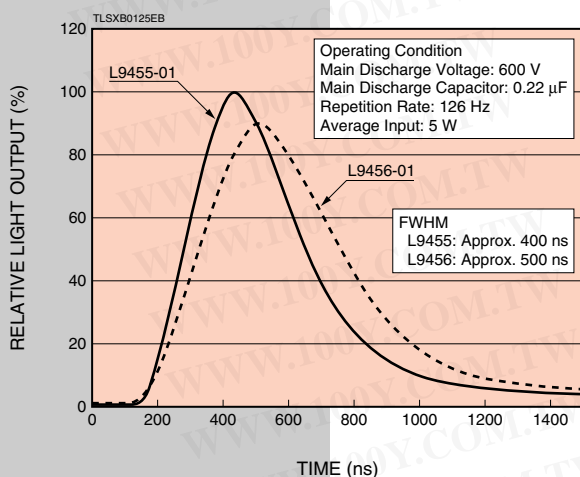

## LINE-UP

### Standard Type (without Fiber Adapter)

Type No.	Arc Size (mm)	Main Discharge Capacitor ( $\mu$ F) <sup>®</sup>
L9455-01 / L11035-01	1.5	0.22
L9455-02 / L11035-02		0.11
L9455-03 / L11035-03		0.047
L9456-01 / L11036-01	3.0	0.22
L9456-02 / L11036-02		0.11
L9456-03 / L11036-03		0.047

### With SMA Fiber Adapter Type

Type No.	Arc Size (mm)	Main Discharge Capacitor ( $\mu$ F) <sup>®</sup>
L9455-11 / L11035-11	1.5	0.22
L9455-12 / L11035-12		0.11
L9455-13 / L11035-13		0.047

# SPECIFICATIONS

Type No.	Arc Size (mm)	Window Material	Spectral Distribution (nm)	Main Discharge Voltage Adjustable Range (V) <sup>(A)</sup>	Main Discharge Capacitor (μF) <sup>(B)</sup>	Max. Average Input [Continuous] (W) <sup>(C)</sup>	Max. Average Input Energy [flash] (J) <sup>(D)</sup>	Max. Repetition Rate (Hz)	Light Output Stability (% CV) <sup>(E)</sup>	Guaranteed Life (flash) <sup>(F)</sup>	Input Voltage Range (V)	Cooling <sup>(G)</sup>
L9455 Series / L11035 Series	1.5	UV Glass	185 to 2000	400 to 600	0.047 0.11 0.22	5	See below table	See below table	2.0 <sup>(E)</sup>	1.0 × 10 <sup>9</sup>	11 to 28	Natural <sup>(F)</sup> air cooling
L9456 Series / L11036 Series	3.0								1.5 <sup>(E)</sup>			

(A): Adjustable with internal trimmer potentiometer or external voltage supply of 3.2 V to 4.8 V. (B): Adjusted at factory prior to shipment.  
 (C): Maximum average input (continuous) W is given by:  $W = E \times f$  [W], where E is the maximum input energy (J) and f is the repetition frequency (Hz).  
 (D): Maximum average input energy (per flash) E is given by:  $E = 1/2 CV^2$  [J], where V is the main discharge voltage (V) and the main discharge capacitance (F) for C.  
 (E): Calculated by: standard deviation / average light output × 100 [%] (F): At 5-watt operation  
 (G): Cooling is required if temperature on the lamp module exceeds 50 °C during operation.

# OPERATING CONDITIONS

Type No.	Main Discharge Capacitor (μF) <sup>(B)</sup>	Main Discharge Voltage (V)	Max. Average Input Energy: per flash <sup>(D)</sup> (mJ)	Max. Repetition Rate (Hz)	Max. Average Input (W) <sup>(C)</sup>
L945-□-□1 L1103-□-□1	0.22	400	17.6	284	5.0
		500	27.5	182	5.0
		600	39.6	126	5.0
L945-□-□2 L1103-□-□2	0.11	400	8.8	530	4.7
		500	13.8	362	5.0
		600	19.8	252	5.0
L945-□-□3 L1103-□-□3	0.047	400	3.8	530	2.0
		500	5.9	530	3.1
		600	8.5	530	4.5

NOTE: Please refer to above "NOTE"

# DIMENSIONAL OUTLINE (Unit: mm)

## Standard Type

### ●L9455-0□ Series / L9456-0□ Series

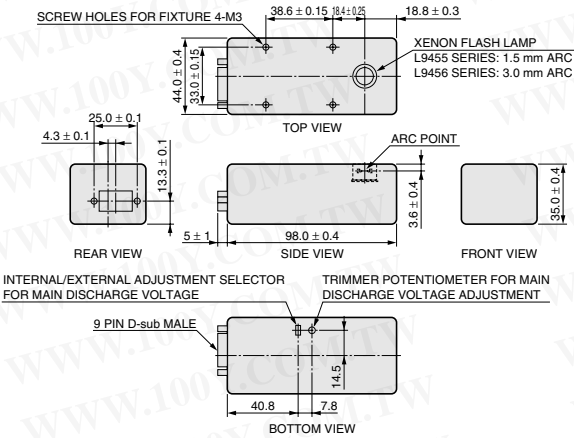

### ●L11035-0□ Series / L11036-0□ Series

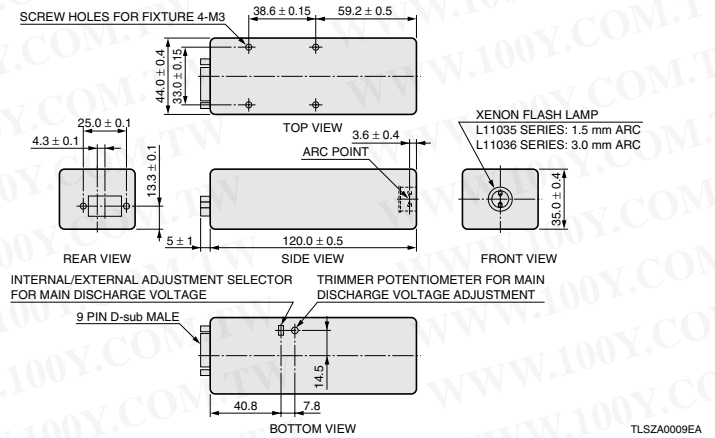

## With SMA Fiber Adapter Type

### ●L9455-1□ Series

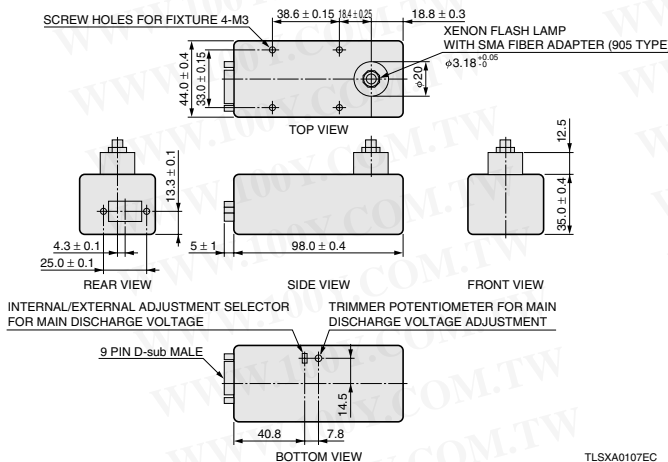

### ●L11035-1□ Series

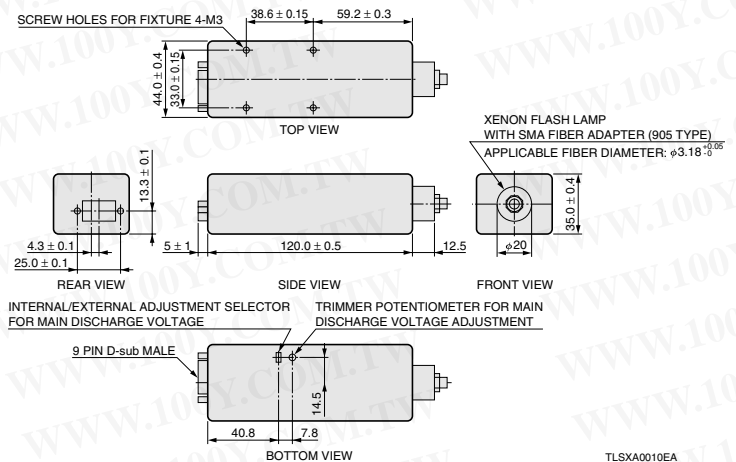

Chemical analysis

Biological research

**HQ**  
(High Quality)

**TYPE**

**[10W]**

# High stability, compact, reasonable price

In spite of using a low cost cathode as the electrode, HQ (High Quality) type xenon flash lamps feature high stability and easy handling. The lamp outer diameter is 20 mm which is the smallest size among Hamamatsu xenon flash lamps. Two window shapes are available: flat and hemispherical. Lamp service life is extended up to  $1 \times 10^9$  flashes which nearly equal to that of SQ type flash lamps.



## High stability; Fluctuation (p-p): 1% Typ. (at 10 Hz operation)

Output stability (%) = { (maximum light output – minimum light output) / average light output } × 100

### Xenon flash lamp light output stability vs. operating time

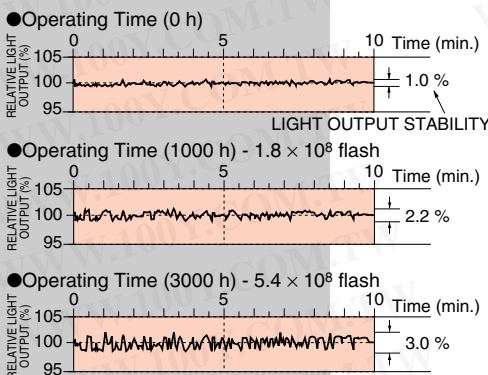

#### Operating conditions

MAIN DISCHARGE VOLTAGE : 1000 V  
MAIN DISCHARGE CAPACITOR : 0.1 μF  
REPETITION RATE : 50 Hz  
WAVELENGTH : 400 nm

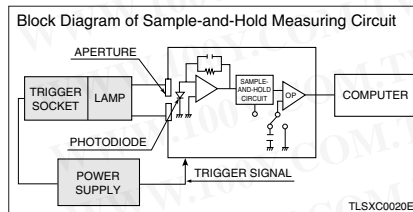

### Light output stability vs. flash repetition rate

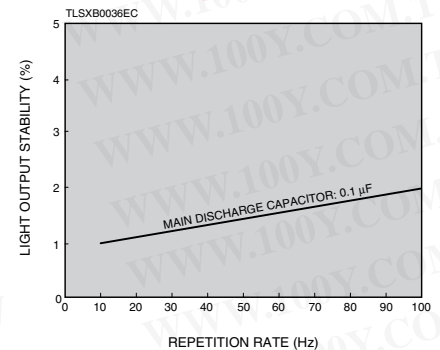

## SPECIFICATIONS

Type No.	Arc Size (mm)	Dimensional Outline	Bulb Shape	Window Material	Spectral Distribution (nm)	Recommended Supply Voltage (V dc)	Trigger Voltage p-p (kV)	Max. Average Input [Continuous] (W)	Max. Average Input Energy [Single] (J/flash)	Repetition Rate Max. (Hz)	Light Output Stability Max. (%) <sup>(A)</sup>	Life Min. (flash) <sup>(B)</sup>	Cooling	Applicable Trigger Sockets	Equivalent Lamps
----------	---------------	---------------------	------------	-----------------	----------------------------	-----------------------------------	--------------------------	-------------------------------------	--	---------------------------	--	----------------------------------	---------	----------------------------	------------------

### 20 mm Dia. Type

L4644	3.0	①-a	Hemispherical	UV Glass	185 to 2000	700 to 1000	5 to 7	10	0.1	100	3	1 × 10 <sup>9</sup>	Not required	E2418 E6188	Excelitas FX1100 series
L4646		②-a	Flat												
L4645		①-a	Hemispherical	Borosilicate Glass	240 to 2000										
L4647		②-a	Flat												
L4640	1.5	①-b	Hemispherical	UV Glass	185 to 2000	700 to 1000	5 to 7	10	0.1	100	3.5	1 × 10 <sup>9</sup>	Not required	E2442 E6186	Excelitas FX1100 series
L4642		②-b	Flat												
L4641		①-b	Hemispherical	Borosilicate Glass	240 to 2000										
L4643		②-b	Flat												

(A): Measured with supply voltage of 1000 V, main discharge capacitor of 0.1 μF, repetition rate of 50 Hz and wavelength of 400 nm.

(B): Lamp service life mainly depends on the input energy, though it also depends somewhat on the average power and peak current.

For typical life characteristics versus input energy, see the data graph on page 8.

Input energy E is calculated as follows:  $E = CV^2/2$  [J], C: main discharge capacitance (F), V: supply voltage (V dc).

# DIMENSIONAL OUTLINE (Unit: mm)

## 1 L4640, L4641, L4644, L4645

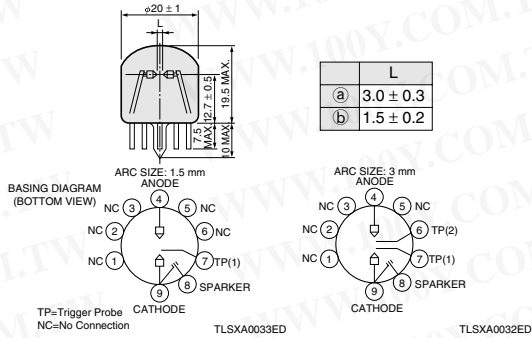

## 2 L4642, L4643, L4646, L4647

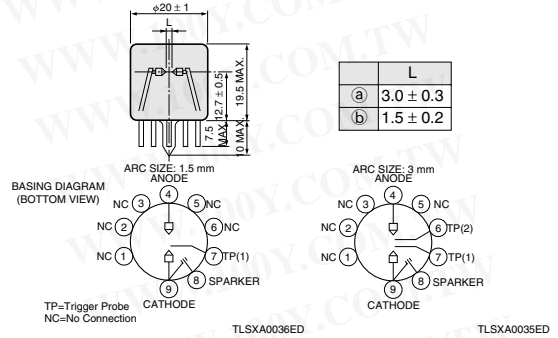

## OPTIONS

### Trigger Sockets

Hamamatsu provides trigger sockets specifically designed to quickly start operating the xenon flash lamp. These trigger sockets are integrated with a "high voltage transformer", "voltage dividing resistors" and "capacitors" in the same compact case. This frees the user from the troublesome task of designing and assembling the external circuit. The E2418 and E2442 use a metal package designed to minimize noise emission, while the general-purpose E6186 and E6188 use a plastic package that offers low cost and is suitable for applications where noise emission is not a critical factor.

\* Changing the length of the trigger socket cable varies the current flowing through the lamp so the lamp might fail to meet its required specifications. Use the cable length as shipped.

## DIMENSIONAL OUTLINE (Unit: mm)

### For 20 mm · 22 mm Dia. E2418 · E2442

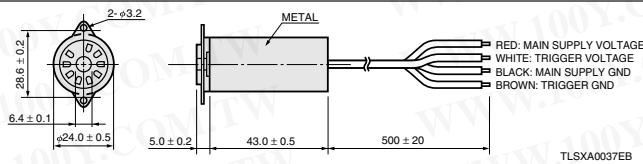

### For 20 mm · 22 mm Dia. E6186 · E6188

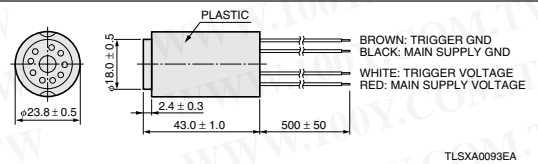

## Lamp Modules C5604, C5605 (for 10 W)

These lamp modules integrate a HQ type lamp\* and accessories (trigger socket and power supply) into an easy-to-use compact case. These modules require no troublesome wiring and are easily installed into equipment.

These modules are operable with external TTL level trigger signals and controllable from a PC.

\* Lamp is sold separately.



## SPECIFICATIONS

### [Main Power Supply]

Parameter	Discription / Value
Output Voltage <sup>Ⓐ</sup> (DC)	300 V to 1000 V
Output Capacity	10 W Max.
Output Voltage Ripple (p-p)	0.5 %
Built-in Capacitor	0.1 μF
Max. Repetition Rate	100 Hz
Internal trigger Circuit	Yes (10 Hz to 100 Hz)

### [Trigger Input Section]

Input Waveform <sup>Ⓑ</sup>	Rectangular waveform
Input Voltage	+5 V peak (TTL Level)

### [Line Input Section]

Input voltage (DC)	12 V ± 0.6 V
Input Current	1.5 A Max.

<sup>Ⓐ</sup> Output voltage can be adjusted by the internal trimmer potentiometer, or controlled by an external voltage input.

<sup>Ⓑ</sup> Lamp starts to flash at the rising edge of a square wave pulse. The pulse width of the square wave should be greater than 5 μs on 10 W lamp modules.

## DIMENSIONAL OUTLINE (Unit: mm)

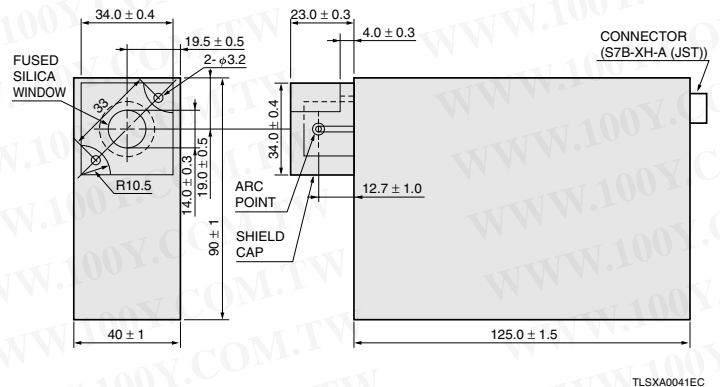

## APPLICABLE LAMPS (HQ Type)

Module Type No.	C5604	C5605
Lamp Type No.	L4640 L4641 L4642 L4643	L4644 L4645 L4646 L4647

Chemical analysis Biological research Factory Automation

**SQ**  
(Super Quiet)  
**TYPE**

**[10W/15W]**

## Long service life, high stability

SQ type xenon flash lamps use a high-performance BI cathode (barium-impregnated electrode) for the anode and cathode. Electrode wear is drastically reduced, even in these short-arc lamps to deliver a long service life. This means that SQ type flash lamps now deliver excellent stability over their entire extended service life.

**High-performance BI cathode (barium-impregnated electrode):** The BI cathode has various advantages such as high electron emissivity, low operating temperature and resistance to ion bombardment. The electrode is cone-shaped to concentrate an electrical field onto the electrode tip so a stable discharge is maintained. The BI cathode has also been used as the electrode in continuous mode lamps and been highly acclaimed for product use.



## Long service life $1.2 \times 10^9$ flashes

■ Life characteristics vs. energy per flash (reference data)

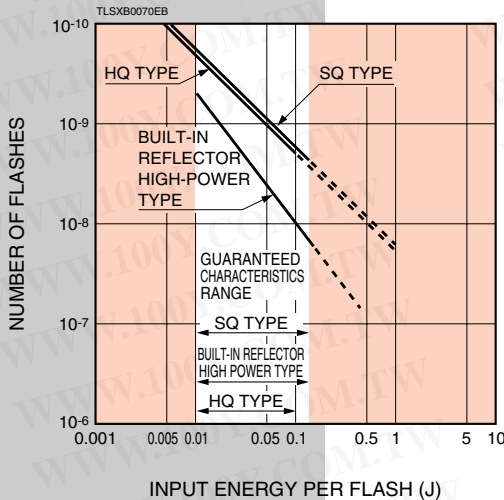

■ Life characteristics (radiant intensity vs. operating time)

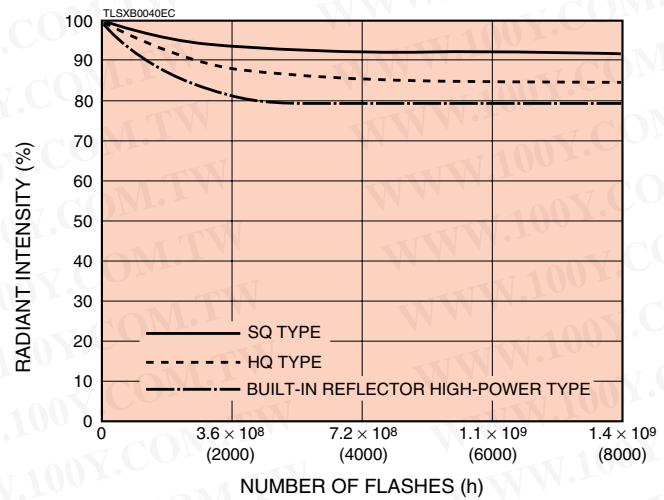

**Operating conditions**

Main discharge voltage : 1000 V  
Main discharge capacitor : 0.1  $\mu$ F  
Repetition Rate : 50 Hz

Guaranteed service life end is defined as the time at which the radiant intensity falls to 50 % of its initial value or when the light output fluctuation exceeds the rated specifications.

## SPECIFICATIONS

Type No.	Arc Size (mm)	Dimensional Outline	Window Material	Spectral Distribution (nm)	Recommended Supply Voltage (V dc)	Trigger Voltage p-p (kV)	Max. Average Input [Continuous] (W)	Max. Average Input Energy [Single] (J/flash)	Repetition Rate Max. (Hz)	Light Output Stability Max. (%) <sup>(A)</sup>	Life Min. (flash) <sup>(B)</sup>	Cooling	Applicable Trigger Sockets	Equivalent Lamps
----------	---------------	---------------------	-----------------	----------------------------	-----------------------------------	--------------------------	-------------------------------------	--	---------------------------	--	----------------------------------	---------	----------------------------	------------------

### 22 mm Dia. Type

L2415*	3.0	①-a	Synthetic Silica	160 to 2000	700 to 1000	5 to 7	10	0.1	100	2.5	$1.2 \times 10^9$	Not required	E2418	Excelitas FX1100 series
L2416*			UV Glass	185 to 2000										
L2417*			Borosilicate Glass	240 to 2000										
L2439*	1.5	①-b	Synthetic Silica	160 to 2000	700 to 1000	5 to 7	10	0.1	100	3.5	$1.2 \times 10^9$	Not required	E2442	Excelitas FX1100 series
L2440*			UV Glass	185 to 2000										
L2441*			Borosilicate Glass	240 to 2000										

# SPECIFICATIONS

Type No.	Arc Size (mm)	Dimensional Outline	Window Material	Spectral Distribution (nm)	Recommended Supply Voltage (V dc)	Trigger Voltage p-p (kV)	Max. Average Input [Continuous] (W)	Max. Average Input Energy [Single] (J/flash)	Repetition Rate Max. (Hz)	Light Output Stability Max. (%) <sup>(A)</sup>	Life Min. (flash) <sup>(B)</sup>	Cooling	Applicable Trigger Sockets	Equivalent Lamps
----------	---------------	---------------------	-----------------	----------------------------	-----------------------------------	--------------------------	-------------------------------------	--	---------------------------	--	----------------------------------	---------	----------------------------	------------------

## 26 mm Dia. Type

L2187	8.0	②-a	Synthetic Silica	160 to 2000	700 to 1000	5 to 7	15	0.15	100	2.5	$1.2 \times 10^9$	Not required	E2191 series	—
L2188			UV Glass	185 to 2000										
L2189			Borosilicate Glass	240 to 2000										
L2358	3.0	②-b	Synthetic Silica	160 to 2000	700 to 1000	5 to 7	15	0.15	100	2.5	$1.2 \times 10^9$	Not required	E2361 series	—
L2359			UV Glass	185 to 2000										
L2360			Borosilicate Glass	240 to 2000										
L2435	1.5	②-c	Synthetic Silica	160 to 2000	700 to 1000	5 to 7	15	0.15	100	3.5	$1.2 \times 10^9$	Not required	E2438 series	Excelitas FX1130 series
L2436			UV Glass	185 to 2000										
L2437			Borosilicate Glass	240 to 2000										

## 28 mm Dia. Type

L2443*	8.0	③-a	Synthetic Silica	160 to 2000	700 to 1000	5 to 7	15	0.15	100	2.5	$1.2 \times 10^9$	Not required	E2446	—
L2444*			UV Glass	185 to 2000										
L2445*			Borosilicate Glass	240 to 2000										
L2447*	3.0	③-b	Synthetic Silica	160 to 2000	700 to 1000	5 to 7	15	0.15	100	2.5	$1.2 \times 10^9$	Not required	E2450	—
L2448*			UV Glass	185 to 2000										
L2449*			Borosilicate Glass	240 to 2000										
L2451*	1.5	③-c	Synthetic Silica	160 to 2000	700 to 1000	5 to 7	15	0.15	100	3.5	$1.2 \times 10^9$	Not required	E2454	Excelitas FX1130 series
L2452*			UV Glass	185 to 2000										
L2453*			Borosilicate Glass	240 to 2000										

(A): Measured with supply voltage of 1000 V, main discharge capacitor of 0.1 μF, repetition rate of 50 Hz and wavelength of 400 nm.

(B): Lamp service life mainly depends on the input energy, though it also depends somewhat on the average power and peak current. For typical life characteristics versus input energy, see the data graph on the preceding page. Input energy E is calculated as follows:  $E = CV^2 \cdot 1/2$  [J], C: main discharge capacitance (F), V: supply voltage (V dc). \*: Manufactured upon receiving your order

# DIMENSIONAL OUTLINE (Unit: mm)

## ① 22 mm Dia. Type

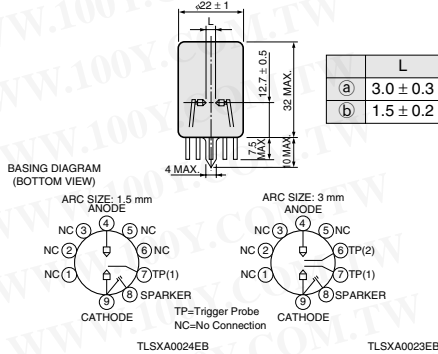

## ② 26 mm Dia. Type

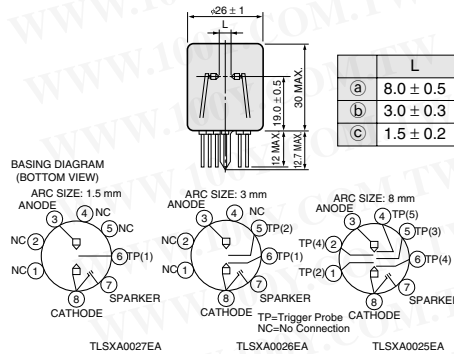

## ③ 28 mm Dia. Type

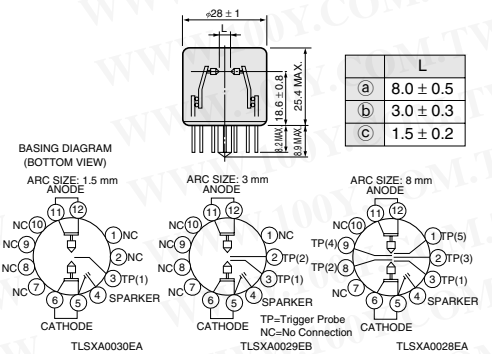

# OPTIONS

## Trigger Sockets

Hamamatsu provides trigger sockets specifically designed to quickly start operating the xenon flash lamp. These trigger sockets are integrated with a "high voltage transformer", "voltage dividing resistors" and "capacitors" in the same compact case. This frees the user from the troublesome task of designing and assembling the external circuit.

\* Changing the length of the trigger socket cable varies the current flowing through the lamp so the lamp might fail to meet its required specifications. Use the cable length as shipped.

# DIMENSIONAL OUTLINE (Unit: mm)

## For 22 mm Dia. E2418 · E2442

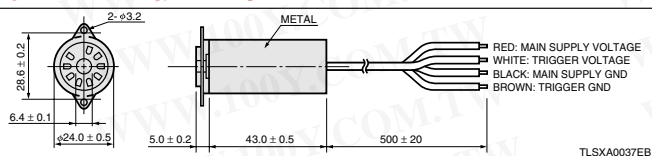

## For 26 mm Dia. E2191 · E2361 · E2438

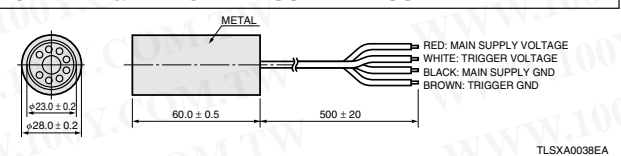

## For 26 mm Dia. (Shield Cable Type) E2191-01 · E2361-01 · E2438-01

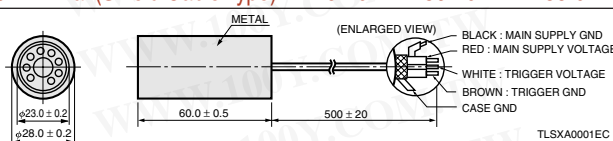

## For 28 mm Dia. E2446 · E2450 · E2454

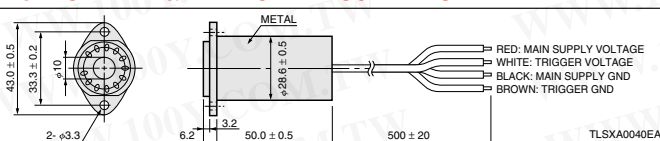



**BUILT-IN REFLECTOR HIGH OUTPUT TYPE**

**[ 15 W ]**

## Built-in reflector for high output, efficient light input to light guide

Equipped with a precisely assembled built-in reflector, these lamps deliver a light output 4 times higher than SQ lamps of the same electrical input. The light is output as a converging light flux or collimating light flux without using any optical system, making these lamps convenient to use. The reflector is made of aluminum that reflects light very efficiently over a wide wavelength range, and is selectable from the converging or collimating type. The converging type is ideal for applications where light needs to be input to a light guide. We also provide light guides as options.



## Output light is efficiently input to light guide

### Light distributions of converging type L4633 and collimating type L4634

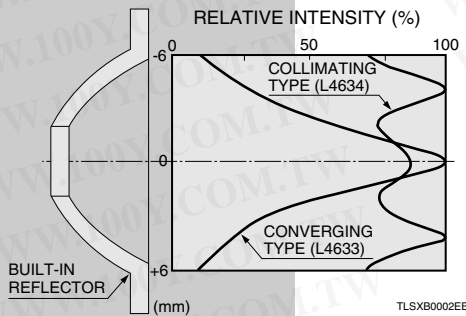

### Comparison of radiant intensities

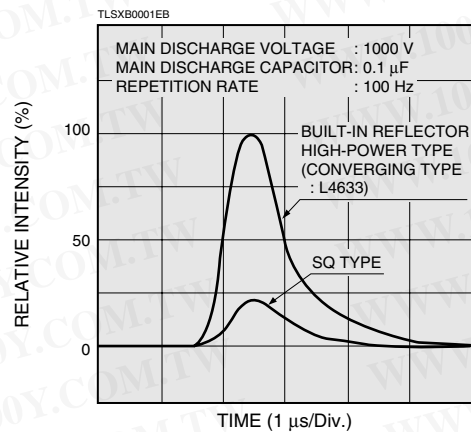

### Output light solid angle of converging type L4633

Taking the aperture angle of a quartz optical fiber into account, the converging type L4633 was designed to output light flux at a solid angle of 17 degrees. This allows direct input of a light flash into the quartz optical fiber.

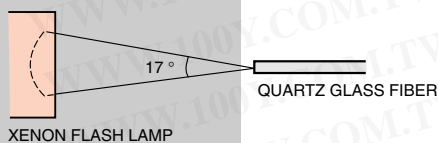

### Stability of light output from light guide

Stability of light output depends on the type (aperture angle) of the light guide being used. The smaller the aperture angle, the better the stability.

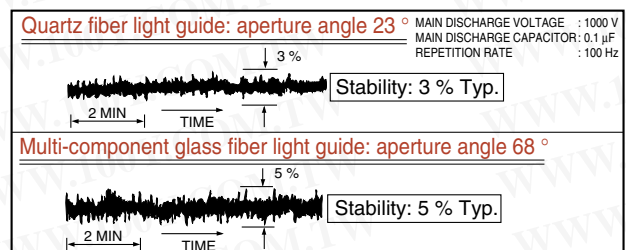

# SPECIFICATIONS

Type No.	Arc Size (mm)	Dimensional Outline	Output Light	Window Material	Spectral Distribution (nm)	Recommended Supply Voltage (V dc)	Trigger Voltage p-p (kV)	Max. Average Input [Continuous] (W)	Max. Average Input Energy [Single] (J/flash)	Repetition Rate Max. (Hz)	Light Output Stability Max. (%) <sup>(A)</sup>	Life Min. (flash) <sup>(B)</sup>	Cooling	Applicable Trigger Sockets	Equivalent Lamps
L4633	1.5	①	Converging	Borosilicate Glass	240 to 2000	700 to 1000	5 to 7	15	0.15	100	5	5 × 10 <sup>8</sup>	Not required	E4370-01	—
L4633-01*				UV Glass	185 to 2000										
L4634		②	Collimating	Borosilicate Glass	240 to 2000										
L4634-01*				UV Glass	185 to 2000										

(A): Measured with supply voltage of 1000 V, main discharge capacitor of 0.1 μF, repetition rate of 50 Hz and wavelength of 400 nm.

(B): Lamp service life mainly depends on the input energy, though it also depends somewhat on the average power and peak current. For typical life characteristics versus input energy, see the data graph on page 6. Input energy E is calculated as follows:  $E = CV^2 \cdot 1/2$  [J], C: main discharge capacitance (F), V: supply voltage (V dc).

\*: Manufactured upon receiving your order

## DIMENSIONAL OUTLINE (Unit: mm)

### ① L4633, L4633-01

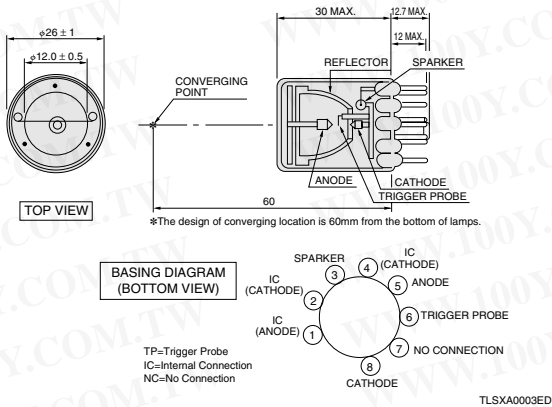

### ② L4634, L4634-01

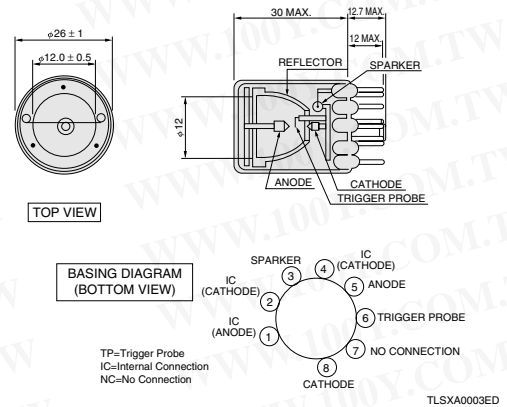

## OPTIONS

### Trigger Sockets

Hamamatsu provides trigger sockets specifically designed to quickly start operating the xenon flash lamp. These trigger sockets are integrated with a "high voltage transformer", "voltage dividing resistors" and "capacitors" in the same compact case. This frees the user from the troublesome task of designing and assembling the external circuit.

\* Changing the length of the trigger socket cable varies the current flowing through the lamp so the lamp might fail to meet its required specifications. Use the cable length as shipped.

### DIMENSIONAL OUTLINE (Unit: mm)

For 26 mm Dia. (Shield Cable Type) E4370-01

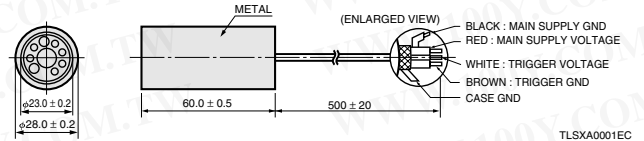

### Shield Box E2608

(Lamp: 26 mm Dia. Type, Trigger Socket: E2191-01 · E2361-01 · E2438-01 · E4370-01)

Xenon flash lamps start an initial discharge upon input of a high trigger voltage of 5 kV to 7 kV. An instantaneous current of several hundred amperes then flows to cause the main discharge, so electromagnetic noise is generated at this instant. This noise must be eliminated when using the flash lamps as light sources for high precision photometry. Hamamatsu provides the E2608 metal shield box designed expressly for this purpose. This shield box also suppresses lamp noise that occurs at each flash.

### DIMENSIONAL OUTLINE (Unit: mm)

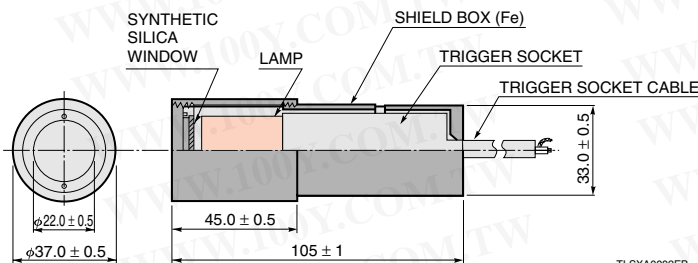

\*Shield box containing lamp and trigger socket



# High output, efficient light input to light guide

## 60 W TYPE

### [ 60 W ]

These 60 W flash lamps employ a metal can package to achieve high input power and high output. Select these 60 W flash lamps when your application requires a high light output. Despite a high output, these lamps are highly stable so output fluctuation is held within 3 % maximum. To provide an even higher output, a variant type with built-in reflector (spherical mirror) that boosts the output 1.5 times is also available. As useful options, Hamamatsu provides dedicated power supplies (see page 12), cooling jacket, main discharge capacitor, and light guides (see page 9). When using a flash lamp with a 15 W or higher input, always use a cooling jacket and main discharge capacitor.



## Lineup includes 60 W flash lamp with built-in reflector

■ Spectral distribution

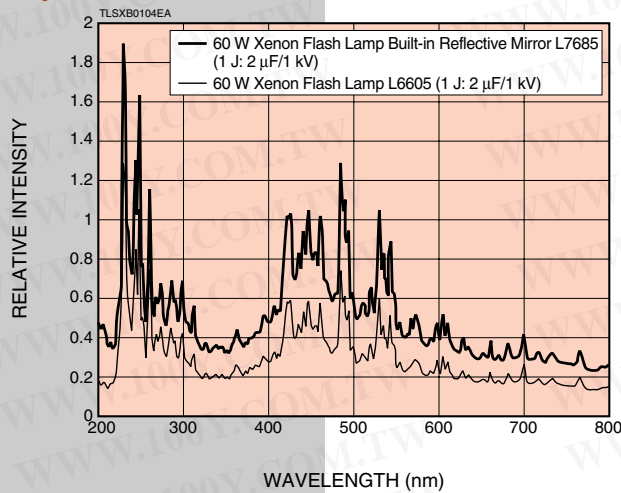

■ Life characteristics

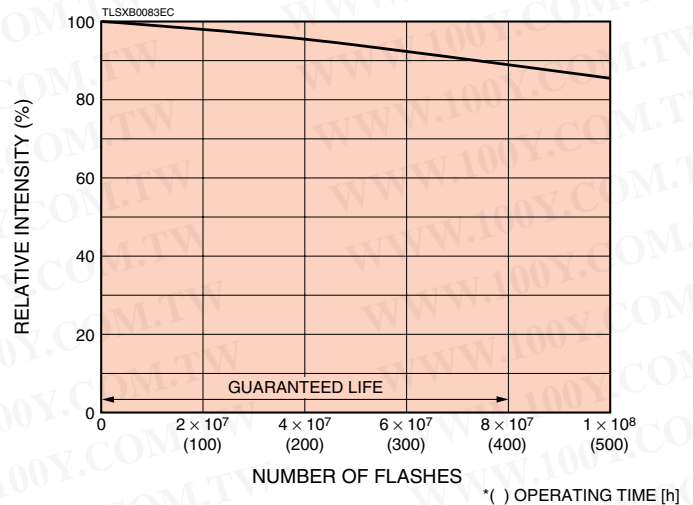

MAIN DISCHARGE VOLTAGE: 1000 V  
 MAIN DISCHARGE CAPACITOR: 2 μF  
 REPETITION RATE: 60 Hz  
 INPUT ENERGY: 1 J / FLASH

Values in parentheses show operating time in hours. Guaranteed service life end is defined as the time at which the radiant intensity falls to 50 % of its initial value or when the light output fluctuation exceeds the rated specifications.

## SPECIFICATIONS

Type No.	Arc Size (mm)	Dimensional Outline	Window Material	Spectral Distribution (nm)	Recommended Supply Voltage (V dc)	Trigger Voltage p-p (kV)	Max. Average Input [Continuous] (W)	Max. Average Input Energy [Single] (J/flash)	Repetition Rate Max. (Hz)	Light Output Stability Max. (%)	Life Min. (flash)	Applicable Trigger Sockets	Equivalent Lamps
----------	---------------	---------------------	-----------------	----------------------------	-----------------------------------	--------------------------	-------------------------------------	--	---------------------------	---------------------------------	-------------------	----------------------------	------------------

### 60 W Type

L6604	3.0	①	Borosilicate Glass	240 to 2000	700 to 1000	5 to 10	60	1	60	3	8 × 10 <sup>7</sup>	E6647	—
L6605			Sapphire Glass	190 to 2000									

### 60 W Built-in Reflective Mirror Type

L7684	3.0	②	Borosilicate Glass	240 to 2000	700 to 1000	5 to 10	60	1	60	3	8 × 10 <sup>7</sup>	E6647	—
L7685			Sapphire Glass	190 to 2000									

Ⓐ: Measured with supply voltage of 1000 V, main discharge capacitor of 2 μF, repetition rate of 10 Hz and wavelength of 400 nm. Ⓑ: Lamp service life mainly depends on the input energy, though it also depends somewhat on the average power and peak current. Input energy E is calculated as follows:  $E = CV^2 \cdot 1/2$  [J], C: main discharge capacitance (F), V: supply voltage (V dc). Ⓒ: Average input W is calculated as follows:  $W = E \times f$  [W], f: repetition rate (Hz) Ⓓ: Repetition rate when the input energy per flash is 1 J. Operable up to 100 Hz when the average input is 60 W or less.

## DIMENSIONAL OUTLINE (Unit: mm)

### ① L6604, L6605

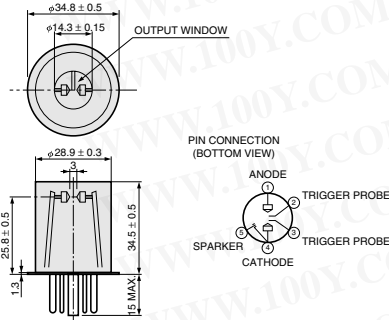

TLSXA0049EC

### ② L7684, L7685

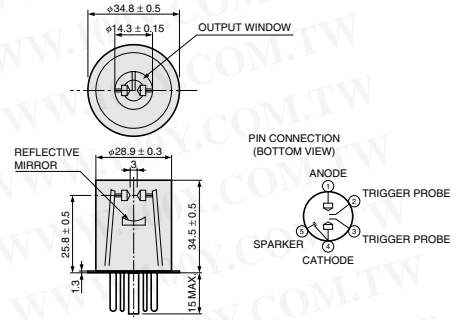

TLSXA0082EA

## OPTIONS

### Trigger Sockets

Hamamatsu provides trigger sockets specifically designed to quickly start operating the xenon flash lamp. These trigger sockets are integrated with a "high voltage transformer", "voltage dividing resistors" and "capacitors" in the same compact case. This frees the user from the troublesome task of designing and assembling the external circuit.

\* Changing the length of the trigger socket cable varies the current flowing through the lamp so the lamp might fail to meet its required specifications. Use the cable length as shipped.

### DIMENSIONAL OUTLINE (Unit: mm)

For 60 W E6647

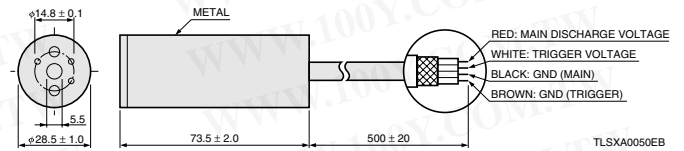

TLSXA0050EB

### Cooling Jacket E6611

The E6611 is a cooling jacket specifically designed for use with a 60 W xenon flash lamp. The built-in cooling fan suppresses the temperature of the lamp and other electronic parts in the trigger socket to within a tolerable range for maintaining a constant operating temperature and stable performance. This cooling jacket must be used when the lamp is operated with an input of 15 W or more.

### DIMENSIONAL OUTLINE (Unit: mm)

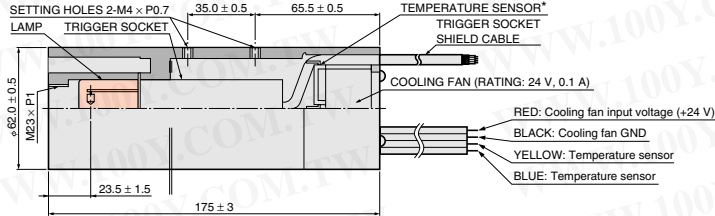

\* The temperature sensor turns on when the temperature of the lamp or internal parts increases abnormally due to a cooling fan failure. If the fan fails when the protective terminals of the dedicated power supply C6096 are connected to the temperature sensor, the C6096 cuts off the power to protect the trigger socket, lamp and power supply.

TLSXA0052ED



### Main Discharge Capacitor (External Connection) E7289-02

The E7289-02 is a main discharge capacitor (2 μF) designed to operate a 60 W xenon flash lamp at 60 W (input energy per flash: 1 J, repetition rate: 60 Hz). Safe operation can start by just connecting to the power supply.

### DIMENSIONAL OUTLINE (Unit: mm)

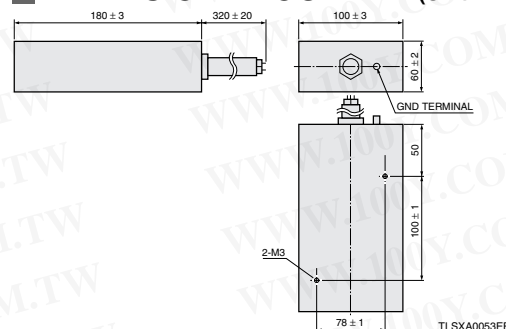

TLSXA0053EE



### Light Guides

Fiber optic light guides are useful when irradiating light directly onto an object is impossible due to equipment structures or because the light flux must be branched onto several points. Since xenon flash lamps are short-arc lamps, the output light can be easily and efficiently directed into a light guide. Hamamatsu supplies two types of light guides to meet different applications. A light guide holder for a 60 W type cooling jacket is also available. (This light guide holder is supplied along with a cooling jacket.) Contact our sales office for more details.

Type No.	Light guide Material	Transmission Wavelength	Light Exit Diameter	Length	Aperture Angle
A2873	Quartz fiber	220 nm to 1300 nm	φ5 mm	1 m	23 °
A7432	Glass fiber	380 nm to 1300 nm	φ5 mm	1 m	67 °



## OPTIONS

### ●Power Supplies

The radiant intensity of xenon flash lamps is nearly proportional to the input energy. This means that a highly regulated power supply is required to obtain better performance from the lamp.

Hamamatsu xenon flash lamp power supplies are switching power supplies having a high-speed charging circuit and discharge stop circuit. This ensures a large power capacity for stable lamp operation while keeping the design compact.



①C10979, ②C10980-10, ③C5728, ④C5398

### SPECIFICATIONS

Parameter		C5398	C5728	C10979	C10980-10	C6096	Unit
Main Power Supply	Output Voltage (DC)	480 to 720	300 to 1000	300 to 1000	300 to 1000	300 to 1000	V
	Output Capacity	5	10	20	20	60	W Max.
	Stability	±1.0	±1.0	±0.2	±0.2	±1.0	% max.
	Main Supply Capacitor	—	0.1	0.1	1.0 <sup>Ⓐ</sup>	0.1	μF
	Max. Repetition Rate	200	200	1000 <sup>Ⓑ</sup>	1000 <sup>Ⓑ</sup>	100 <sup>Ⓒ</sup>	Hz
Trigger Section	Output Voltage	140	140	150	150	180	V Typ.
	Trigger Capacitor	0.22	0.22	0.22	0.22	0.22	μF
Trigger Input Section	Trigger Type	External	Internal / External	Internal / External	Internal / External	Internal / External	—
	Repetition Rate	—	10 to 100	10 to 100	10 to 100	10 to 100	Hz
	Trigger Input Impedance	1	1	0.33	0.33	0.36	kΩ
Input Section	Input Waveform	Rectangular waveform	Rectangular waveform	Rectangular waveform	Rectangular waveform	Rectangular waveform	—
	Input Voltage	5	5	5 to 10	5 to 10	5	V peak
Input Voltage (DC)		12 ± 1.2	12 ± 1.2	24 ± 2.4	24 ± 2.4	24 ± 1.2	V
Power Consumption		8.5	17	26	26	90	W
Cooling		No required	No required	No required	No required	No required	—
Dimensions (W × H × D)		25 × 29 × 100	75 × 43 × 154	90 × 43 × 146	102 × 51 × 170	108 × 49 × 174	mm
Weight		200	500	570	810 <sup>Ⓓ</sup>	550	g
Applicable Lamp <sup>Ⓔ</sup>		HQ Type, SQ Type	HQ Type, SQ Type	Built-in Reflector High Output Type	Built-in Reflector High Output Type	60 W type	—

**NOTE:** <sup>Ⓐ</sup>Adjusted at pre-shipment inspection. Capacitance ranges from 0.2 μF to 1.0 μF, in increments of 0.1 μF.

Please contact us if other than 1.0 μF is requested.

<sup>Ⓑ</sup>Need to adjust it to the specification of lower than 15 W.

<sup>Ⓒ</sup>Need to adjust it to the specification of lower than 60 W.

<sup>Ⓓ</sup>Depend on the main discharge capacitance.

<sup>Ⓔ</sup>Average input to the lamp is less than the output capacity in the main discharge section.

# Precautions When Using Xenon Flash Lamps

## **WARNING** (FOR YOUR SAFETY)



- Lamps emit intense ultraviolet radiation. Never directly stare into the operating lamp.
- Do not allow skin to be exposed to the ultraviolet radiation from the operating lamp.
- The lamp must be installed in a proper housing before operation. Lamp housings must be designed to prevent hazards from flying glass fragments in the event the lamp ruptures.
- Take extreme caution not to drop the lamp, subject it to impacts, apply excessive force to it or scratch it, because the lamp is under high internal pressure and may rupture.
- Always turn off the power supply when installing or removing the lamp, or when cleaning any part of the equipment.

## **CAUTION** (FOR YOUR SAFETY)

- Always operate the lamp at a main supply voltage of 700 Vdc to 1000 Vdc.
- Do not use the lamp in damp locations subject to moisture or water droplets, or at high humidity.
- Always wear a protective mask and garment when installing or removing the lamp.
- Securely insert the lamp into the socket.
- Securely connect the socket leads to the terminal strip of the power supply.
- Do not subject the lamp to drop impact, vibration and shock.
- Wipe the lamp bulb and window using soft cloth moistened with high-quality alcohol before operation. Never touch the glass bulb of the lamp with bare hands, because dust or fingerprints on the glass bulb may greatly reduce transmittance in the ultraviolet range.
- Always operate the lamp within the input energy.  
\*For more details, refer to our technical manual.

## **Warranty**

Products listed in this catalog are warranted for one year after shipment from Hamamatsu Photonics. The warranty is limited to repair or replacement of defective parts or products. Even if within the warranty period (one year), this warranty shall not apply to case where lamp operation time has exceeded the guaranteed service life time or trouble occurred due to misoperation, mishandling or accidents such as natural or man-made disasters.

## **When scrap the product**

When scrap the product, please follow the appropriate disposal regulation for wasted products, if any, of the country/state/region/province in use, or pass to those who can handle the disposal at proper manner like approved/licensed. Any question may arise, feel free to contact our office nearby.

# RELATED PRODUCTS

## Xenon Lamps

Hamamatsu super quiet xenon lamps are point light sources with extremely high brightness and color temperature that emit a continuous spectrum from the UV to infrared region, making them ideal as light sources in a variety of photometric applications such as spectrophotometers.

These super quiet lamps employ a high performance BI cathode (barium-impregnated electrode) that ensures extremely enhanced stability and long service life. Hamamatsu xenon lamps are available in five inputs (35 W, 75 W, 100 W, 150 W and 300 W) and in two types of glass bulbs (fused silica and ozone-free silica).



## Mercury-Xenon Lamps

Hamamatsu mercury-xenon lamps are sealed with an optimum mixture of mercury and xenon gas to provide high radiant energy especially in the UV region. The spectral distribution includes a continuous spectrum from UV to infrared of xenon gas and an intense line spectra of mercury in the UV to visible region. Hamamatsu mercury-xenon lamps also feature instantaneous lighting and re-lighting, which is difficult to achieve in conventional super-high-pressure mercury lamps.

These features make our mercury-xenon lamps an excellent choice as UV light sources.



勝特力材料 886-3-5753170  
勝特力电子(上海) 86-21-34970699  
勝特力电子(深圳) 86-755-83298787  
[Http://www.100y.com.tw](http://www.100y.com.tw)

\* A technical booklet "Super-Quiet Xenon Flash Lamps" is available from Hamamatsu. For your free copy, please contact our sales office.

\* Patent pending: Japan (11), USA (4), Europe (15)

Subject to local technical requirements and regulations, availability of products included in this promotional material may vary. Please consult with our sales office.

Information furnished by HAMAMATSU is believed to be reliable. However, no responsibility is assumed for possible inaccuracies or omissions. Specifications are subject to change without notice. No patent rights are granted to any of the circuits described herein. ©2013 Hamamatsu Photonics K.K.

**HAMAMATSU PHOTONICS K.K.** [www.hamamatsu.com](http://www.hamamatsu.com)

**HAMAMATSU PHOTONICS K.K., Electron Tube Division**

**314-5, Shimokanzo, Iwata City, Shizuoka Pref., 438-0193, Japan, Telephone: (81)539/62-5248, Fax: (81)539/62-2205**

**U.S.A.:** Hamamatsu Corporation: 360 Foothill Road, P. O. Box 6910, Bridgewater, N.J. 08807-0910, U.S.A., Telephone: (1)908-231-0960, Fax: (1)908-231-1218 E-mail: [usa@hamamatsu.com](mailto:usa@hamamatsu.com)

**Germany:** Hamamatsu Photonics Deutschland GmbH: Arzbergerstr. 10, D-82211 Herrsching am Ammersee, Germany, Telephone: (49)8152-375-0, Fax: (49)8152-2658 E-mail: [info@hamamatsu.de](mailto:info@hamamatsu.de)

**France:** Hamamatsu Photonics France S.A.R.L.: 19, Rue du Saule Trapu, Parc du Moulin de Massy, 91882 Massy Cedex, France, Telephone: (33)1 69 53 71 00, Fax: (33)1 69 53 71 10 E-mail: [infos@hamamatsu.fr](mailto:infos@hamamatsu.fr)

**United Kingdom:** Hamamatsu Photonics UK Limited: 2 Howard Court, 10 Tewin Road Welwyn Garden City Hertfordshire AL7 1BW, United Kingdom, Telephone: 44-(0)1707-294888, Fax: 44(0)1707-325777 E-mail: [info@hamamatsu.co.uk](mailto:info@hamamatsu.co.uk)

**North Europe:** Hamamatsu Photonics Norden AB: Thorshamnsgatan 35 SE-164 40 Kista, Sweden, Telephone: (46)8-509-031-00, Fax: (46)8-509-031-01 E-mail: [info@hamamatsu.se](mailto:info@hamamatsu.se)

**Italy:** Hamamatsu Photonics Italia: S.R.L.: Strada della Moia, 1/E, 20020 Arese, (Milano), Italy, Telephone: (39)02-935 81 733, Fax: (39)02-935 81 741 E-mail: [info@hamamatsu.it](mailto:info@hamamatsu.it)

**China:** Hamamatsu Photonics (China) Co., Ltd.: 1201 Tower B, Jiaoming Center, 27 Dongsanhuan Road North, Chaoyang District, Beijing 100020, China, Telephone: (86)10-6586-6006, Fax: (86)10-6586-2866 E-mail: [hpc@hamamatsu.com.cn](mailto:hpc@hamamatsu.com.cn)

TLS 1003E02  
SEPT. 2013 IP