

HID-Basic BSN/BMH MK4 semi-parallel for SON/CDO/CDM/MH/HPI

BSN 250 K300-I 220V 50Hz BC2-151

Impregnated electromagnetic copper ballasts for use with an external semi-parallel ignitor for CDM, CDO, MH, HPI (Plus) and SON lamps

勝特力材料 886-3-5753170
勝特力电子(上海) 86-21-34970699
勝特力电子(深圳) 86-755-83298787
[Http://www.100y.com.tw](http://www.100y.com.tw)

Product data

• General Characteristics

| | |
|--------------------------|---------|
| Rated Number of Lamps | 1 piece |
| Rated Ballast-Lamp Power | 250 |
| Application code | K300-I |
| Line Voltage | 220 V |
| Line Frequency | 50 Hz |
| Design | BC2-151 |

• Operating Characteristics

| | |
|--------------------------------|-----------|
| Input current with PF-correct. | 1.4 A |
| Input current w/o PF-correct. | 3 A |
| Mains voltage safety (AC) | -10%/+10% |
| Mains voltage performance (AC) | -8%/+6% |
| PowerFactor 100% output power | 0.40 - |

• Wiring Characteristics

| | |
|----------------------|---------------------|
| Connector type | Screw |
| Striplength | 7.0 mm |
| Wcs Ballast contacts | 2.5 mm ² |

• Temperature Characteristics

| | |
|-------------------------------|------------------------|
| Active temperature protection | No |
| T-storage | -30 (min), 130 (max) C |

| | |
|---------------------------|-------------|
| T-winding maximum (tw) | 140 (max) C |
| Delta-T normal conditions | 85 C |

• Product Dimensions

| | |
|-------------------------|----------|
| Length A1 | 151.0 mm |
| Width B1 | 76.0 mm |
| Height C1 | 65.0 mm |
| Fixing Hole Diameter D1 | 6.2 mm |

• Approval & Application Chars

| | |
|------------------|-----|
| CE marking | Yes |
| ENEC certificate | No |

• Product Data

| | |
|-----------------------------|----------------------------------|
| Order code | 913700284226 |
| Full product code | 913700284226 |
| Full product name | BSN 250 K300-I 220V 50Hz BC2-151 |
| Order product name | BSN 250 K300-I 220V 50Hz BC2-151 |
| Pieces per pack | 1 |
| Packing configuration | 6 |
| Packs per outerbox | 6 |
| Bar code on pack - EAN1 | 8727900940787 |
| Bar code on outerbox - EAN3 | 8727900940794 |
| Logistic code(s) - 12NC | 913700284226 |
| Net weight per piece | 2.980 kg |

PHILIPS
 sense and simplicity

HID-Basic BSN/BMH MK4 semi-parallel for SON/CDO/CDM/MH/HPI

Dimensional drawing

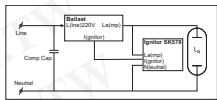
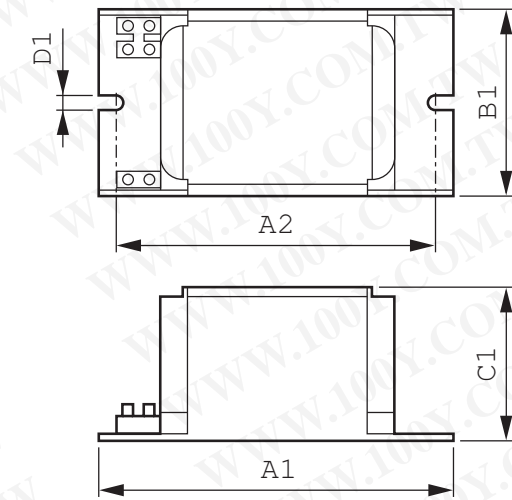

| Product | A1 (Norm) | A2 (Norm) | B1 (Norm) | C1 (Norm) | D1 (Norm) |
|--------------------------|-----------|-----------|-----------|-----------|-----------|
| BSN 250 K300-I 220V 50Hz | 151.0 | - | 76.0 | 65.0 | 6.2 |
| BC2-151 | | | | | |



© 2012 Koninklijke Philips Electronics N.V.
All rights reserved.

Specifications are subject to change without notice. Trademarks are the property of Koninklijke Philips Electronics N.V. or their respective owners.

www.philips.com/lighting

2012, March 2
data subject to change