

Surface Mount Fuse, 7.4 x 3.1 mm, Quick-Acting F, 125 VAC, 125 VDC



勝特力材料 886-3-5753170
 勝特力电子(上海) 86-21-34970699
 勝特力电子(深圳) 86-755-83298787
 Http://www.100y.com.tw

UL 248-14 · 125VAC · 125VDC · Quick-Acting F



Description

- Directly solderable on printed circuit boards

Standards

- UL 248-14
- CSA C22.2 no. 248.14

Approvals

- UL File Number: E41599
- CSA File Number: 51172

References

- [Packaging Details](#)
- Corresponding Fuseholder [OMH 125](#)
- Assembled Fuseholder [OMK 125](#)
- Fuse Kit [Fuse Kit OMF](#)

Weblinks

- [pdf, html, General Product Information, Approvals, RoHS, CHINA-RoHS, e-Store, SCHURTER-Stock-Check, Distributor-Stock-Check](#)

Technical Data

Rated Voltage	125VAC, 125VDC
Rated Current	0.063 - 10A
Breaking Capacity	100A
Characteristic	Quick-Acting F
Mounting	PCB,SMT
Admissible Ambient Air Temp.	-55 °C to 125 °C
Climatic Category	55/125/21 acc. to IEC 60068-1
Material: Housing	Thermoplastic, UL 94V-0
Material: Terminals	Tin-Plated Copper Alloy
Unit Weight	0.08 g
Storage Conditions	0 °C to 60 °C, max. 70% r.h.
Product Marking	Type, Current, Approvals

Soldering Methods	Reflow, Wave
Solderability	245 °C / 3 sec acc. to IEC 60068-2-58, Test Td
Resistance to Soldering Heat	260 +0/-5 °C / 40 sec acc. to IPC/JEDEC J-STD-020D, Level 1
Load Humidity Test	MIL-STD-202, Method 103B 0.1 x ln @ 0.85 r.H. @ 85 °C
Moisture Resistance Test	MIL-STD-202, Method 106E (50 cycles in a temp./mister chamber)
Terminal Strength	MIL-STD-202, Method 211A Deflection of board 1 mm for 1 minute
Case Resistance	acc. to EIA/IS-722, Test 4.7 >100 MΩ (between leads and body)
Mechanical Shock	MIL-STD-202, Method 213B (Shock 50gn, half sine wave, 11 ms)
Vibration, High Frequency	MIL-STD-202, Method 204D Shock 20 gn, 20 min, 10-2 kHz, 12 cyc.
Resistance to Solvents	MIL-STD-202, Method 215A
Flammability	min. UL 94V-1 (acc. to EIA/IS-722, Test 4.12)

Dimensions

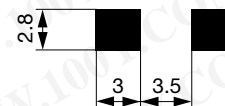
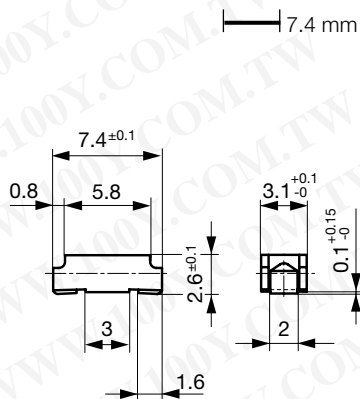

Soldering pads

Pre-Arcing Time

Rated Current In	1.0 x In min.	2.0 x In max.	4.0 x In max.
0.063 A - 5 A	4 h	1 s	10 ms
6.3 A - 8 A	4 h	5 s	50 ms
10 A	4 h	20 s	60 ms

Variants

Rated Current [A]	Rated Voltage [VAC]	Rated Voltage [VDC]	Breaking Capacity	Voltage Drop 1.0 In typ. [mV]	Power Dissipation 1.0 I _n typ. [mW]	Melting I ² t 4.0 In typ. [A ² s]	CCC		Order Number
0.063	125	125	1)	2550	160	0.00011	●	●	3404.0003.xx
0.1	125	125	1)	1770	180	0.00067	●	●	3404.0004.xx
0.125	125	125	1)	1770	220	0.0011	●	●	3404.0049.xx
0.16	125	125	1)	1700	270	0.0018	●	●	3404.0005.xx
0.25	125	125	1)	990	250	0.0058	●	●	3404.0006.xx
0.35	125	125	1)	990	350	0.0076	●	●	3404.0043.xx
0.375	125	125	1)	990	370	0.013	●	●	3404.0044.xx
0.4	125	125	1)	960	380	0.016	●	●	3404.0007.xx
0.5	125	125	1)	350	150	0.01	●	●	3404.0045.xx
0.63	125	125	1)	290	180	0.02	●	●	3404.0008.xx
0.75	125	125	1)	260	200	0.031	●	●	3404.0046.xx
1	125	125	1)	220	220	0.078	●	●	3404.0009.xx
1.25	125	125	1)	220	280	0.14	●	●	3404.0010.xx
1.5	125	125	1)	200	300	0.24	●	●	3404.0047.xx
1.6	125	125	1)	200	320	0.27	●	●	3404.0011.xx
2	125	125	1)	200	400	0.44	●	●	3404.0012.xx
2.5	125	125	1)	190	480	0.97	●	●	3404.0013.xx
3	125	125	1)	190	570	1.3	●	●	3404.0014.xx
3.15	125	125	1)	190	600	1.2	●	●	3404.0048.xx
3.5	125	125	1)	140	490	1.6	●	●	3404.0015.xx
4	125	125	1)	140	560	2.1	●	●	3404.0016.xx
5	125	125	1)	140	700	2.9	●	●	3404.0017.xx
6.3	125	125	1)	110	690	14	●	●	3404.0018.xx
7	125	125	1)	105	740	16	●	●	3404.0019.xx
8	125	125	1)	100	800	20	●	●	3404.0020.xx
10	125	125	1)	80	800	54	●	●	3404.0021.xx

1) 100 A @ 125 VAC/DC

Packaging Unit

- .xx = .11 Plastic Bag (100 pcs.)
- .xx = .22 Blister Tape 18 cm Reel (750 pcs.)
- .xx = .24 Blister Tape 33 cm Reel (3000 pcs.)

Time-Current-Curves

