

Think Automation and beyond...

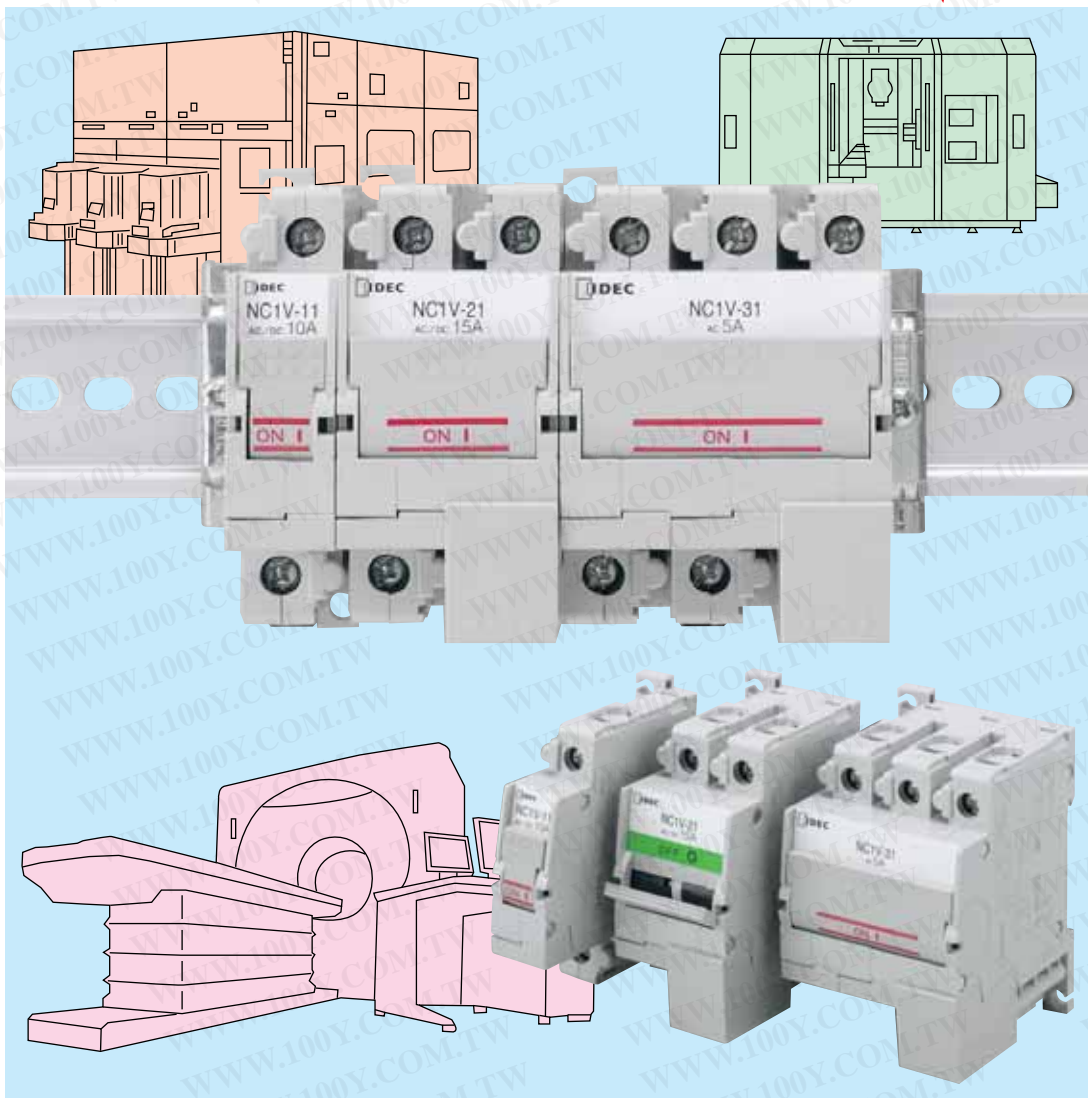

勝特力材料 886-3-5753170  
勝特力电子(上海) 86-21-34970699  
勝特力电子(深圳) 86-755-83298787  
[Http://www.100y.com.tw](http://www.100y.com.tw)

# NC1V Circuit Protectors



IDEC CORPORATION

# IDEC's original Spring-up Terminals and Cover Provide IP20 Finger-safe Protection.

勝特力材料 886-3-5753170  
 勝特力电子(上海) 86-21-34970699  
 勝特力电子(深圳) 86-755-83298787  
[Http://www.100y.com.tw](http://www.100y.com.tw)

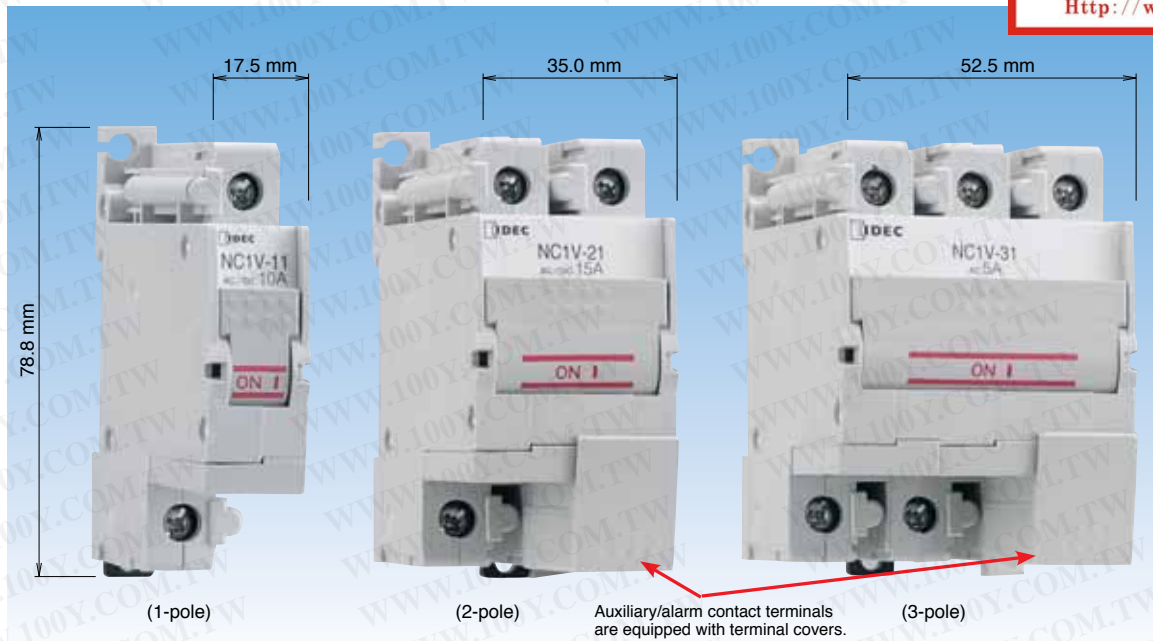

## Finger-safe, spring-up terminals reduce wiring time.

Ring terminal tabs can be installed easily, and screws are held secure.

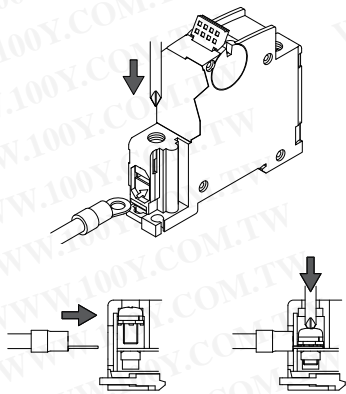

## Retractable Actuator

The actuator retracts when the circuit protector turns on. Inadvertent operation, due to touching the actuator, is prevented. Status of the circuit protector can easily be confirmed by viewing the position of the actuator.

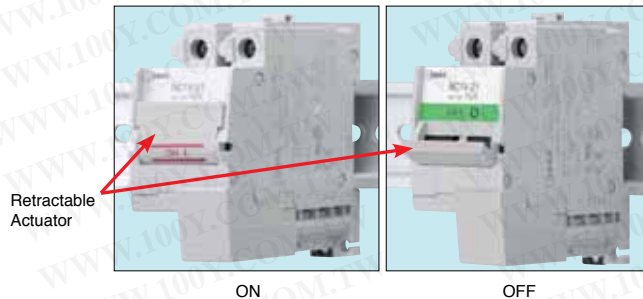

## Slim Housing Saves Space

1-pole	17.5mm Wide
2-pole	35.0mm Wide
3-pole	52.5mm Wide

## Main Circuit Terminals are Fingersafe (IP20)

Spring-up, fingersafe structure requires no terminal cover.

## Auxiliary/Alarm Contact Terminals are Equipped with a Terminal Cover

Voltage coil terminals on the relay trip version are also equipped with a terminal cover as standard.

# Auxiliary/Alarm Contact, and Relay Trip Voltage Coil Terminals are Equipped with a Terminal Cover.

## 35mm-wide DIN Rail Mounting or Direct Panel Mounting



## Conforms to various international standards



## After tripping, the retractable actuator is in the middle position.

Circuit protector must be turned off before it can be reset.

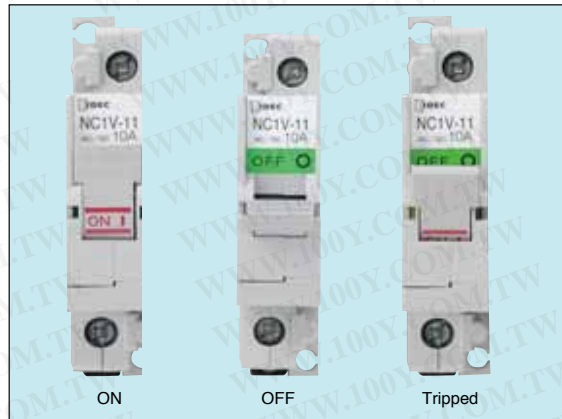

## Distinguishing Characteristics

Wide variety of rated currents and tripping curves. One and 2-pole models are AC/DC compatible and allow for a reduction in inventory.

## Rated Short-circuit Capacity 2500A

## Available with Inertia Delay

Allows for use with large inrush currents such as motors and lamps.

## Safe Trip-free Mechanism

The circuit remains open even when the operator is turned on after tripping (unit must be manually reset after removing the cause of the tripping).

## Available with Auxiliary or Alarm Contacts

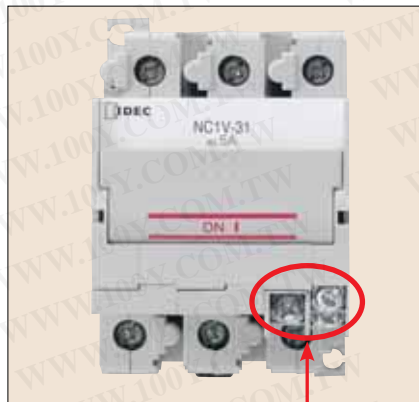

Auxiliary or Alarm Contact  
(Shown without terminal cover.)

勝特力材料 886-3-5753170  
勝特力电子(上海) 86-21-34970699  
勝特力电子(深圳) 86-755-83298787  
[Http://www.100y.com.tw](http://www.100y.com.tw)



# NC1V Circuit Protectors

勝特力材料 886-3-5753170  
 勝特力电子(上海) 86-21-34970699  
 勝特力电子(深圳) 86-755-83298787  
[Http://www.100y.com.tw](http://www.100y.com.tw)

## IDEC's original spring-up, fingersafe terminals enhance reliability and safety.

- Integrated electric shock protection structure (IP20).
- Auxiliary/alarm contact terminals and voltage coil terminals on the relay trip types are equipped with terminal covers.
- Spring-up, fingersafe terminals reduce wiring time.
- Ring terminals can be installed. Captive terminal screws.
- Available with inertia delay
- Available with auxiliary or alarm contacts
- Rated short-circuit capacity: 2500A
- Slim, space-saving housing
  - 1-pole: 17.5mm wide
  - 2-pole: 35.0mm wide
  - 3-pole: 52.5mm wide
- Retractable actuator
- The trip-free mechanism maintains the circuit open even when the operator is turned on after tripping.

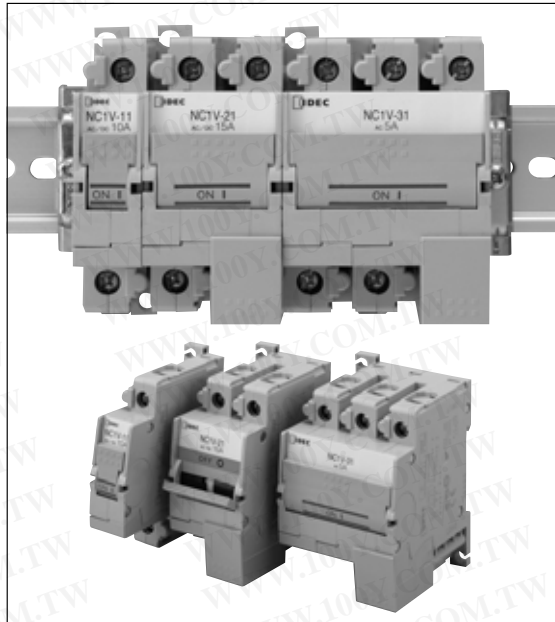

Applicable Standards	Certification Mark	Certification Organization (File No.)
UL1077		E68029
CSA C22.2 No. 235		LR83454
EN60934		B07 09 13332 063
		European Commission's Low Voltage Directive
GB17701-1999		No. 2008010307265840
Electrical Appliance and Material Safety Law Technical Standard	Series Trip	
	Relay Trip	
		JET

Note: TÜV, CE, and CCC marks are applicable for series trip type only.

## Specifications

Operator Style	Retractable actuator		
Internal Circuit	Series trip (current trip), Relay trip (voltage trip)		
Protection Method	Hydraulic magnetic tripping system, Magnetic tripping system (voltage trip)		
No. of Poles	1-pole	2-pole	3-pole
Rated Voltage (AC/DC) (Note 1)	250V AC 50/60Hz, 65V DC	250V AC 50/60Hz, 125V DC	250V AC, 50/60Hz
Series Trip (Current Trip)	Rated Short-circuit Capacity	250V AC, 2500A 65V DC, 2500A	250V AC, 2500A 125V DC, 2500A
	Rated Current	0.1A, 0.3A, 0.5A, 1A, 2A, 3A, 5A, 7A, 10A, 15A, 20A, 25A, 30A	
	Operation Characteristics (Note 2)	Time delay curve curve M (slow), curve A (medium), S (instantaneous) Curves M and A are available with inertia delay.	
Relay Trip (Voltage Trip) (Note 3)	Rated Current	30A	
	Trip Voltage	24 to 48V DC (at 25°C) Voltage application duration 10 sec maximum, tripping time 0.1 sec maximum (at rated voltage)	
Auxiliary Contact/ Alarm Contact	Contact Rating	125V AC 3A (resistive load), 30V DC 2A (resistive load)	
	Minimum Applicable Load	24V DC 1mA (resistive load, reference value)	
Insulation Resistance	100 MΩ minimum (500V DC megger)		
Dielectric Strength	2000V AC, 1 minute (between terminals when main contacts are open, between live parts of different poles, between live and dead parts) 600V AC (between terminals when auxiliary circuits are open)		
Vibration Resistance (with rated current applied)	Damage limits: 147 m/s <sup>2</sup> (10 to 55 Hz) (1-pole, 2-pole), 78 m/s <sup>2</sup> (3-pole) Operating extremes: 98 m/s <sup>2</sup> (1-pole, 2-pole), 78 m/s <sup>2</sup> (3-pole)		
Shock Resistance (S time delay curve: 80% rated current, A, M time delay curve: 100% rated current)	Damage limits: 490 m/s <sup>2</sup> (1-pole, 2-pole), 297 m/s <sup>2</sup> (3-pole) Operating extremes: 196 m/s <sup>2</sup> (S, A, M types)		
Electrical Life	10,000 cycles minimum (at rated current), 10 operations per minute		
Reference Temperature	40°C		
Operating Temperature	-10 to +60°C (no freezing) Rated current is based on an ambient temperature of 40°C. When the operating temperature exceeds 40°C, derate the rated current by using the factors shown below.		
Operating Humidity	45 to 85% RH (no condensation)		
Terminal Style	Main Circuit Terminal	Spring-up, fingersafe terminal: M4 screw (up to 20A), M5 screw (25A and 30A)	
	Auxiliary/Alarm Contacts, Voltage Coil Terminal	M3.5 screw	
Weight (approx.)	1-pole: 90g, 2-pole: 170g, 3-pole: 260g		

Note 1: 3-pole type is for AC voltage only.

Note 2: For S (instantaneous) tripping curve, humming sound may be caused when used in an AC sinusoidal-wave current circuit around 80% of the rated current, however, the performance of the circuit protector will not be affected.  
To avoid unnecessary tripping, do not use in circuits where inrush currents may be present.

Note 3: Relay trip (voltage trip) type is not equipped with an overcurrent trip function.

• Do not use the NC1V circuit protectors in environments where they are exposed to extreme temperature, humidity, dust, corrosive gases, vibration, shock, or in a circuit where inrush current may be present, otherwise unnecessary operations and damage may occur.

Operating Temp.	Derating Factor
50°C	0.9
55°C	0.8
60°C	0.7

Type No. Development

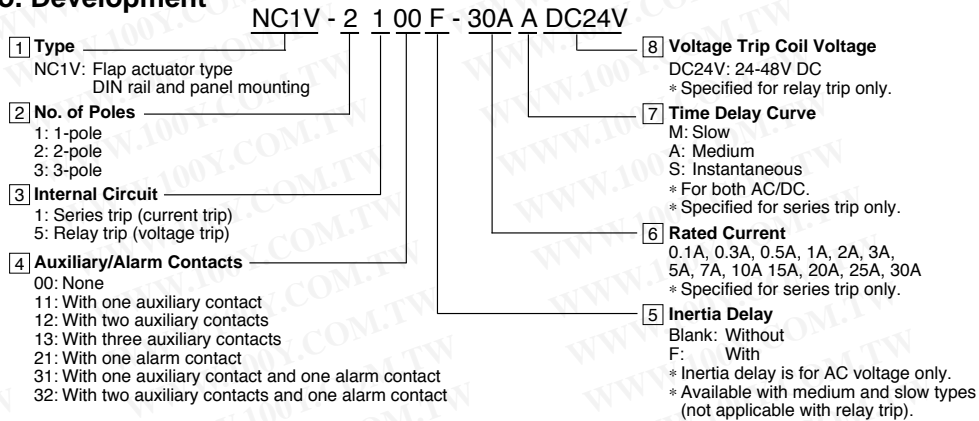

Types

• Specify rated current, time delay curve, or voltage trip coil voltage in place of [6][7][8] in the Ordering Type No.

Internal Circuit	No. of Poles	Inertia Delay	Auxiliary Contact Alarm Contact	Ordering Type No.	Applicable Standards	Code			
						[6] Rated Current	[7] Time Delay Curve	[8] Voltage Trip Coil Voltage	
Series Trip (Current Trip)	1-pole	-	-	NC1V-1100-[6][7]		0.1A 0.3A 0.5A 1A 2A 3A 5A 7A 10A 15A 20A 25A 30A	M (slow) A (medium) S (instantaneous)	-	
			One Auxiliary Contact	NC1V-1111-[6][7]					
			One Alarm Contact	NC1V-1121-[6][7]					
		With	-	NC1V-1100F-[6][7]					
			One Auxiliary Contact	NC1V-1111F-[6][7]					
			One Alarm Contact	NC1V-1121F-[6][7]					
	2-pole	-	-	NC1V-2100-[6][7]					
			One Auxiliary Contact	NC1V-2111-[6][7]					
			Two Auxiliary Contacts	NC1V-2112-[6][7]					
			One Alarm Contact	NC1V-2121-[6][7]					
			One Auxiliary Contact and One Alarm Contact	NC1V-2131-[6][7]					
			With	-	NC1V-2100F-[6][7]				
		One Auxiliary Contact		NC1V-2111F-[6][7]					
		Two Auxiliary Contacts		NC1V-2112F-[6][7]					
		One Alarm Contact		NC1V-2121F-[6][7]					
		One Auxiliary Contact and One Alarm Contact		NC1V-2131F-[6][7]					
		3-pole		-	-				NC1V-3100-[6][7]
			One Auxiliary Contact		NC1V-3111-[6][7]				
	Two Auxiliary Contacts		NC1V-3112-[6][7]						
	Three Auxiliary Contacts		NC1V-3113-[6][7]						
	One Alarm Contact		NC1V-3121-[6][7]						
	One Auxiliary Contact and One Alarm Contact		NC1V-3131-[6][7]						
	With		-	NC1V-3100F-[6][7]					
			One Auxiliary Contact	NC1V-3111F-[6][7]					
Two Auxiliary Contacts			NC1V-3112F-[6][7]						
Three Auxiliary Contacts			NC1V-3113F-[6][7]						
One Alarm Contact			NC1V-3121F-[6][7]						
One Auxiliary Contact and One Alarm Contact			NC1V-3131F-[6][7]						
Relay Trip (Voltage Trip)	1-pole	-	-	NC1V-1500-[8]		-	-	DC24V	
	2-pole	-	-	NC1V-2500-[8]		-	-		
	3-pole	-	-	NC1V-3500-[8]		-	-		

Note: Inertia delay is for AC circuit. Also, time delay curve of S (instantaneous) is not available with inertia delay.

# NC1V Circuit Protectors

**勝特力材料 886-3-5753170**  
**勝特力电子(上海) 86-21-34970699**  
**勝特力电子(深圳) 86-755-83298787**  
[Http://www.100y.com.tw](http://www.100y.com.tw)

## Internal Circuit

### • 1-pole

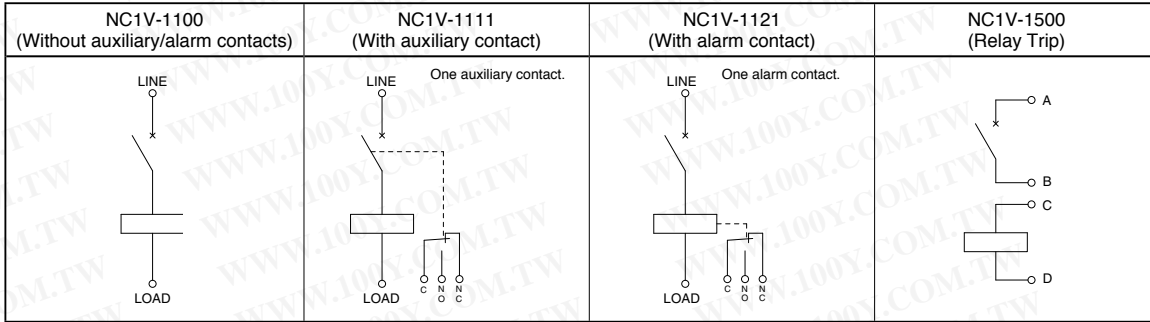

### • 2-pole

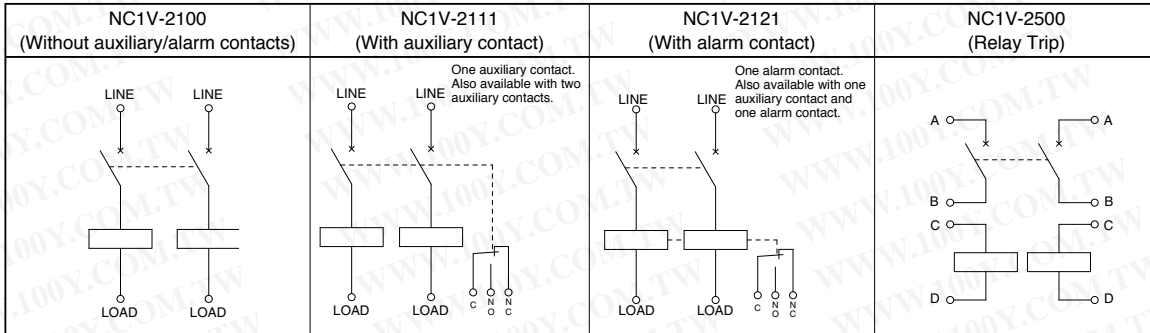

Note: Those with two auxiliary contacts and with one auxiliary contact and one alarm contact have been applied for UL and CCC.

### • 3-pole

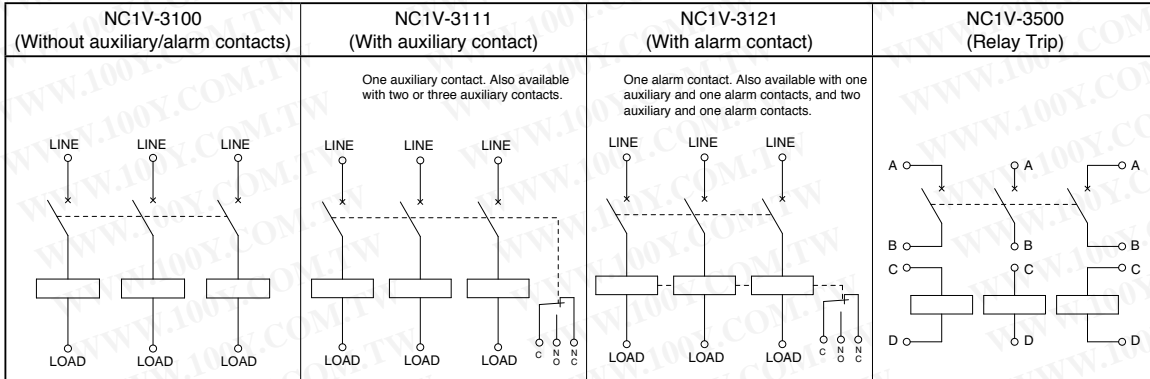

Note: Those with two or three auxiliary contacts, with one auxiliary contact and one alarm contact, and with two auxiliary contacts and one alarm contacts have been applied for UL and CCC.

## Overcurrent-Time Delay Characteristics (sec at 40°C) [vertical mounting]

Item	Time Delay Curve	Percent of Rated Current								
		100%	125%	150%	175%	200%	400%	600%	800%	1000%
AC (50/60 Hz)/DC	S (instantaneous)	NO TRIP	—	*0.005 to 0.1	0.003 to 0.06	0.0027 to 0.05	0.002 to 0.03	0.002 to 0.028	0.002 to 0.025	0.002 to 0.022
	A (medium)	NO TRIP	*25 to 240	16 to 140	—	6 to 32	0.4 to 4	0.0055 to 1.5	0.004 to 0.8	0.004 to 0.65
	M (slow)	NO TRIP	*60 to 600	30 to 200	—	9 to 60	0.4 to 10	0.006 to 4.5	0.004 to 1.8	0.004 to 0.8
AC (50/60 Hz)	With Inertia Delay A (medium)	NO TRIP	25 to 240	—	—	6 to 32	0.8 to 6	0.09 to 3.5	0.02 to 1.8	0.01 to 1.0
	With Inertia Delay M (slow)	NO TRIP	60 to 600	—	—	10 to 60	0.8 to 10	0.06 to 4.5	0.02 to 3	0.01 to 1.75

\*: MAY TRIP on DC

Time Delay Curves at 40°C

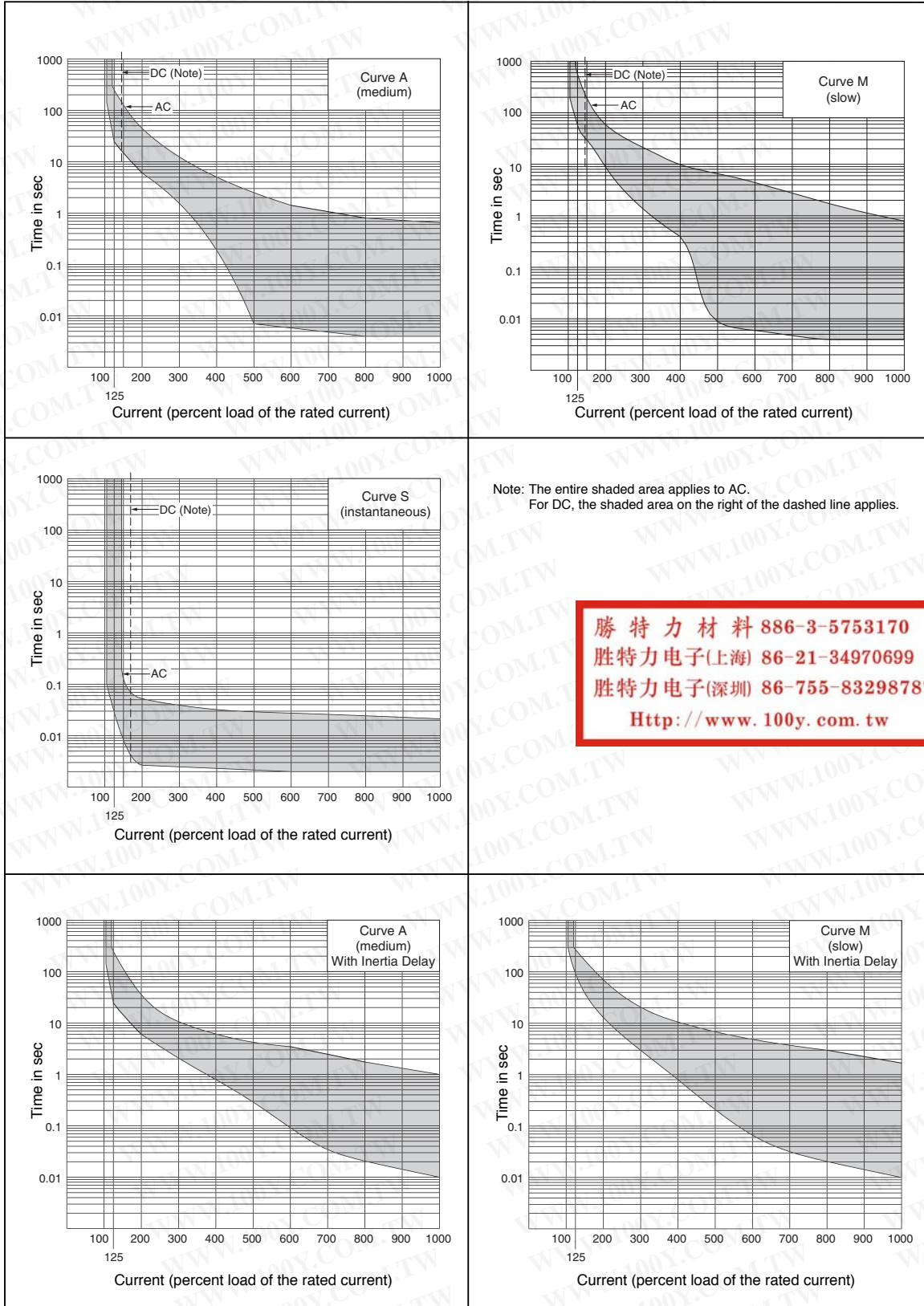

## NC1V Circuit Protectors

### Time Delay Curve and Ambient Temperature

NC1V circuit protectors employ an electromagnetic tripping system, where the rated current (trip current) is not affected by ambient temperatures. But the time delay may vary with the oil viscosity in the oil dash pot. Lower oil viscosity at higher temperatures results in a shorter delay, whereas at lower temperatures the delay will be longer.

### Temperature Correction Curve

The time delay curves on the preceding page are measured at 40°C. With reference to the following curves, time delays can be corrected according to ambient temperature.

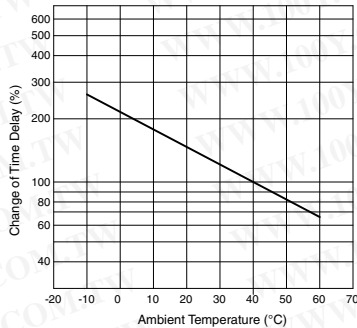

The time delay is based on an ambient temperature of 40°C. Time delays at other temperatures are corrected according to the temperature correction curve. The time delay of the instantaneous time delay curve (S) is not affected by the ambient temperature.

When operating temperature exceeds 40°C, derate the rated current by multiplying the derating factor shown on the right.

Operating Temp.	Derating Factor
50°C	0.9
55°C	0.8
60°C	0.7

### Inertia Delay

Inertia delay is designed not to trip on a non-repeating single pulse of 20 times the rated current (peak value) for a duration of 8 ms. In addition, circuit protectors equipped with inertia delay do not respond to high inrush currents caused by transformer or lamp loads, but perform the specified interruption on the subsequent overcurrents. Inertia delay is available on AC circuits, and is not available with the series trip curve S (instantaneous).

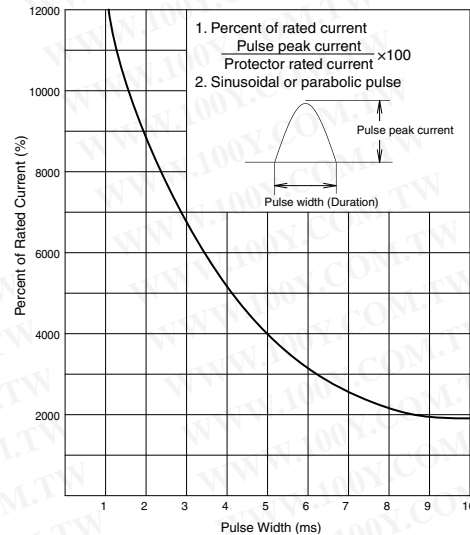

### Impedance and Coil Resistance

#### • Series Trip (Current Trip)

at 25°C

Rated Current	For AC 50/60 Hz Impedance (Ω)		For DC Resistance (Ω)	
	Curve S	Curves A, M	Curve S	Curves A, M
0.1A	66.0	116.0	43.0	106.0
0.3A	6.6	11.0	4.1	10.0
0.5A	1.92	3.65	0.86	3.40
1A	0.50	0.93	0.25	0.90
2A	0.16	0.27	0.11	0.25
3A	0.07	0.12	0.050	0.11
5A	0.025	0.050	0.015	0.045
7A	0.014	0.027	0.011	0.025
10A	0.007	0.021	0.005	0.020
15A	0.006	0.010	0.005	0.009
20A	0.005	0.006	0.004	0.005
25A	0.004	0.005	0.004	0.005
30A	0.003	0.004	0.003	0.004

Tolerance: ±25% (up to 20A),  
 ±50% (25A and 30A)

#### • Relay Trip (Voltage Trip)

at 25°C

Tripping Voltage	For DC Resistance (Ω)
24-48V	100.0

Tolerance: ±25%

### Voltage Drop Due to Coil Resistance or Impedance

The internal resistance or impedance of a circuit protector tends to be larger for a smaller rated current. Therefore, when circuit protectors of a small rated current are used, voltage drop should be taken into consideration. Internal resistance also varies with time delay curves, which should also be considered during installation.

Dimensions

• 1-pole

All dimensions in mm.

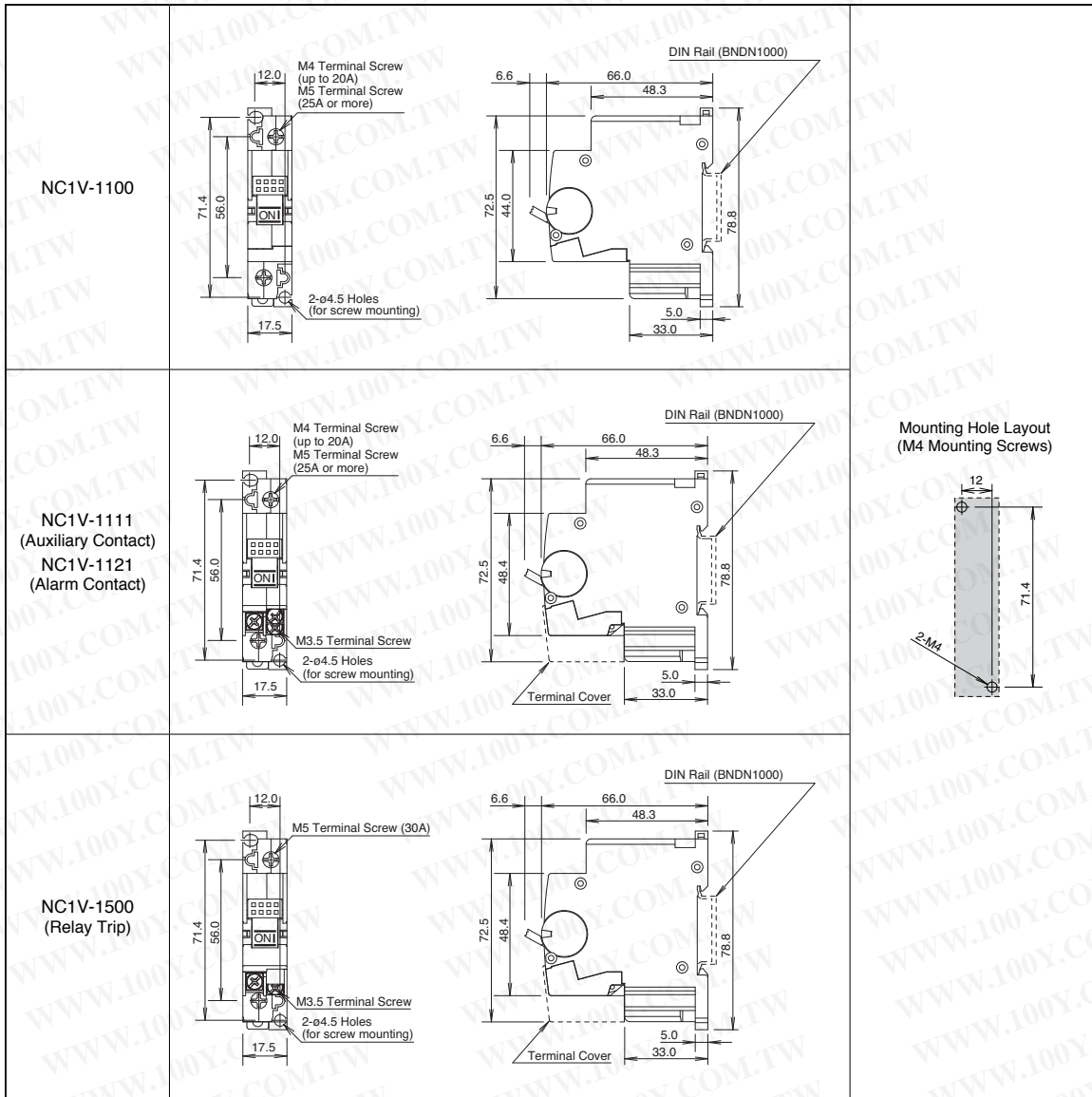

• 2-pole

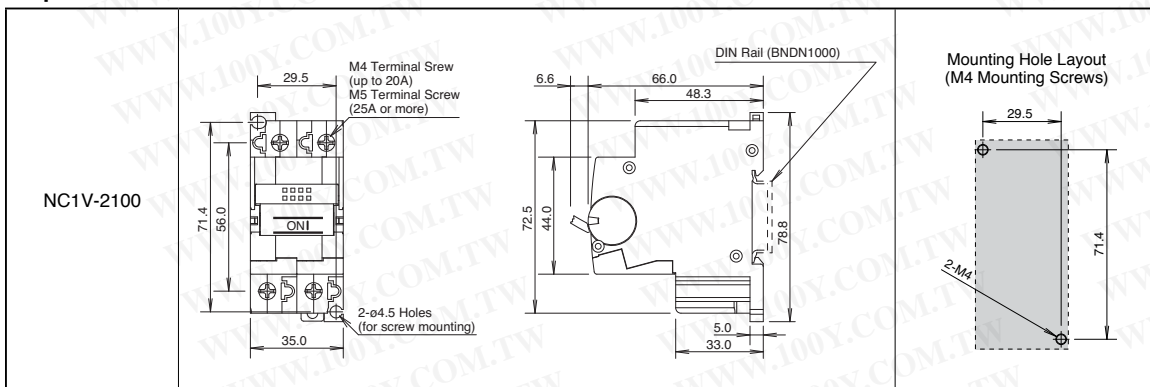

# NC1V Circuit Protectors

勝特力材料 886-3-5753170  
 勝特力电子(上海) 86-21-34970699  
 勝特力电子(深圳) 86-755-83298787  
[Http://www.100y.com.tw](http://www.100y.com.tw)

## • 2-pole

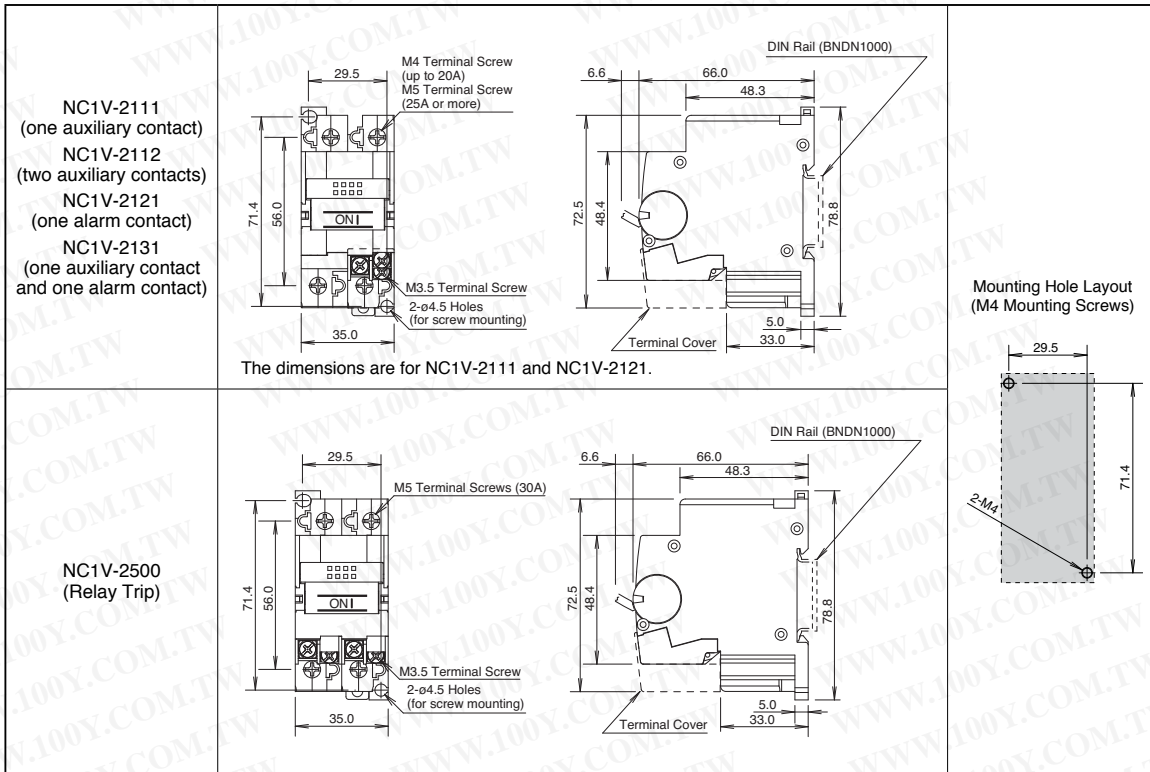

## • 3-pole

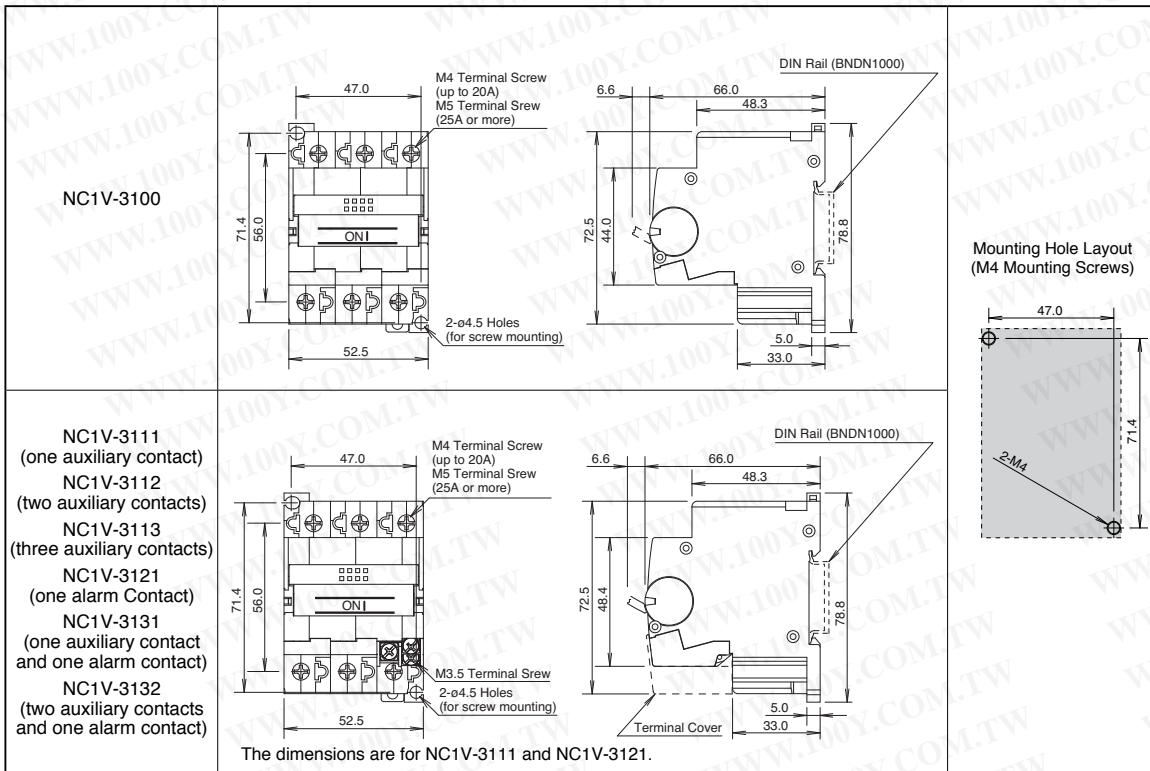

• 3-pole

All dimensions in mm.

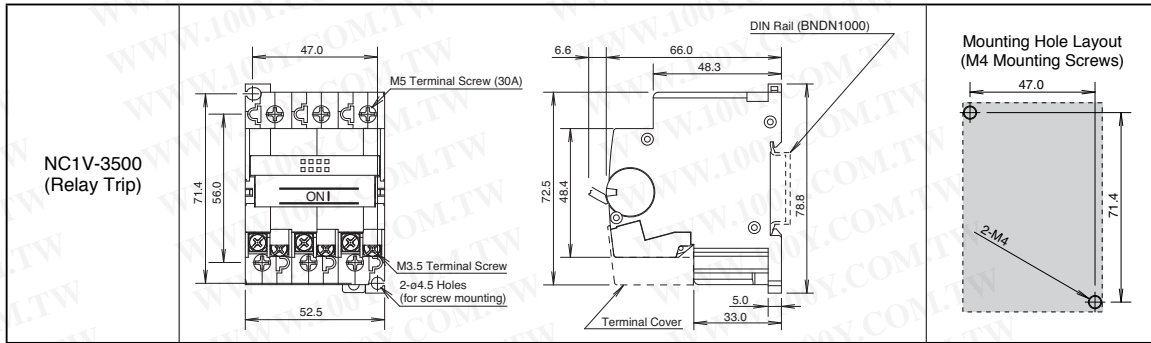

Instructions

• Installation Angle

Tripping method is hydraulic magnetic. Minimum operating current varies with installation angle. Operating currents are influenced by the weight of movable iron core. With reference to the following figures, correct the rated current.

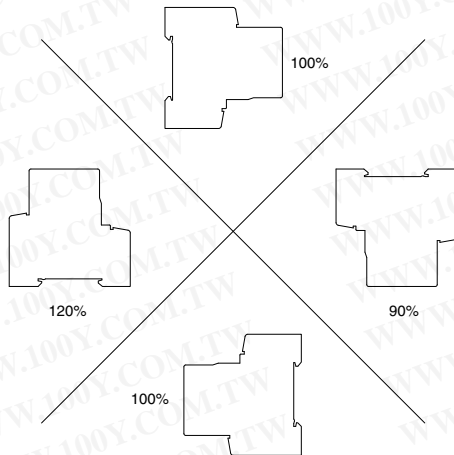

Minimum operating current is calculated from the following formula:  
 (Minimum operating current) = (Rated current) ×  
 (Correction factor by installation angle) × (Reference minimum tripping current rate)

• DIN Rails

[Installation on DIN Rail]

1. Fasten the DIN rail securely.
2. With the latch facing downward, install the NC1V circuit protector on the DIN rail as shown below.

[Removal from DIN Rail]

Using a flat screwdriver, pull the latch on the circuit protector to remove from the DIN rail.

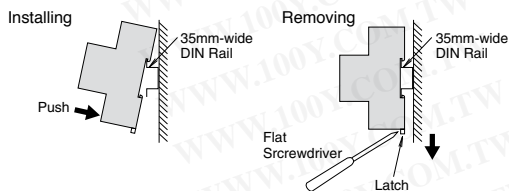

• Applicable Wire and Crimp Terminal

Terminal	Terminal Screw	Connectable Wire Size (mm <sup>2</sup> )	Applicable Crimping Terminal	Tightening Torque (N·m)
Main Circuit Terminals	Spring-up, fingersafe, slotted Phillips screw with square washer (up to 20A)	0.25 to 1.65	R1.25-4	1 to 1.4
		1.04 to 2.63	R2-4	
	Spring-up fingersafe terminal (25A and 30A)	0.25 to 1.65	R1.25-5	1.8 to 2.2
		1.04 to 2.63	R2-5	
Auxiliary Contact Alarm Contact Voltage Coil Terminals	Slotted Phillips screw with square washer	0.25 to 1.65	R1.25-3.5	0.7 to 0.9
		1.04 to 2.63	R2-3.5	

- For wiring the main circuit terminal, use the applicable crimp terminals and tighten to the recommended torque.
- When using the NC1V circuit protector as CSA-certified product, use with CSA-certified crimp terminal.
- When using the NC1V circuit protector as UL-listed product, use with UL-listed crimp terminal.

Panel Mounting Screw (not supplied)

Srew Type	Tightening Torque	Shape
M4	0.8 to 1.0 N·m	Spring Washer Plain Washer

Product Markings (Example: NC1V-1111-30AA)

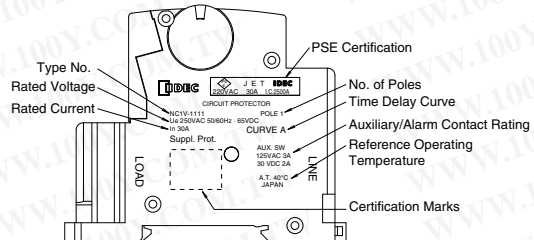

Installation of Auxiliary/Alarm Terminal Cover

After wiring the terminals, install the terminal cover by aligning with the circuit protector as shown below.

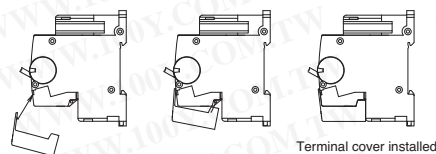

# NC1V Circuit Protectors

勝特力材料 886-3-5753170  
 勝特力电子(上海) 86-21-34970699  
 勝特力电子(深圳) 86-755-83298787  
[Http://www.100y.com.tw](http://www.100y.com.tw)

## Accessories

### • DIN Rail

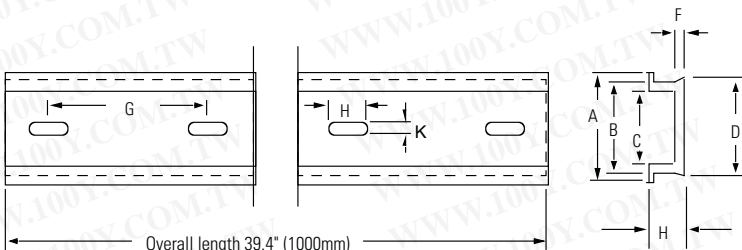

Length	Part No.	Material
1000mm	BNDN1000	Aluminum

### • End Clip



Part No.	Applicable Rail	Material	Package Quantity
BNL6	BNDN1000	Galvanized Trivalent Chromate Treatment	10

### • Auxiliary/Alarm Terminal Cover

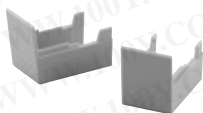

Type No.	Material	Package Quantity
NC1V-AUX-CV	Nylon (PA66)	1

### • Miscellaneous Accessories (available 2009)

Type No.	Description
NC9Z-MA11	Panel Cut-Out Mounting bracket for 1-pole mode
NC9Z-MA21	Panel Cut-Out Mounting bracket for 2-pole model
NC9Z-MA31	Panel Cut-Out Mounting bracket for 3-pole model
NC9Z-TA1	Fast-On Tab terminal Adapter
NC9Z-PW1	Marking Plate
NC9Z-LK1	Lock-Out Bracket