

勝特力材料 886-3-5753170  
勝特力电子(上海) 86-21-54151736  
勝特力电子(深圳) 86-755-83298787  
[Http://www.100y.com.tw](http://www.100y.com.tw)

# FUJI Low Voltage Distribution and Control Equipment



# Fuji Electric FA meets customer needs with a wide range of products and

## Power receiving

**Vacuum circuit breakers**

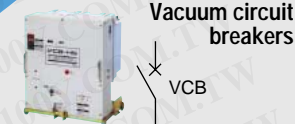

VCB

**Voltage transformers**

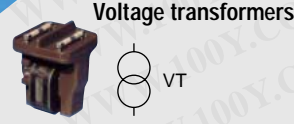

VT

**Pushbuttons  
Selectors  
Pilot lights**



P 14

**Current transformers**



CT

**Power monitoring equipment**



**Multi display lights**



**Cast-resin transformers**

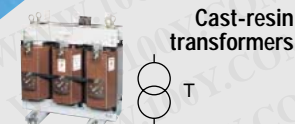

T

**Voltmeters**



**Air circuit breakers**



P 13

**MCCBs  
ELCBs**



P 10

**MCCBs  
ELCBs**



P 10

**MCCBs  
ELCBs**



P 10

**MCCBs  
ELCBs**



P 10

**Manual motor starters**



P 6

**Magnetic contactors and starters**



P 2

**Magnetic contactors and starters**



P 2

**Magnetic contactors**



P 6

**Semiconductor fuses**



**Inverters  
Servo system**



**Combination starters**



**Solid state contactors**



Motor load 1

Motor load 2

Motor load 3

Heaters

# solid reliability

Fuji Electric FA Components & Systems Co., Ltd. provides a wide range of component equipment and system products, such as power distribution, control, and drive control equipment, to support the operation and safety of factory FA lines, intelligent buildings, and other applications.



**Time delay relays**  
P 17



**Industrial control relays**  
P 18



**Current-limiting fuses**



**Panel switches**



**Ammeters**



**Protective relays**



**Terminal blocks**



**Surge protective devices**

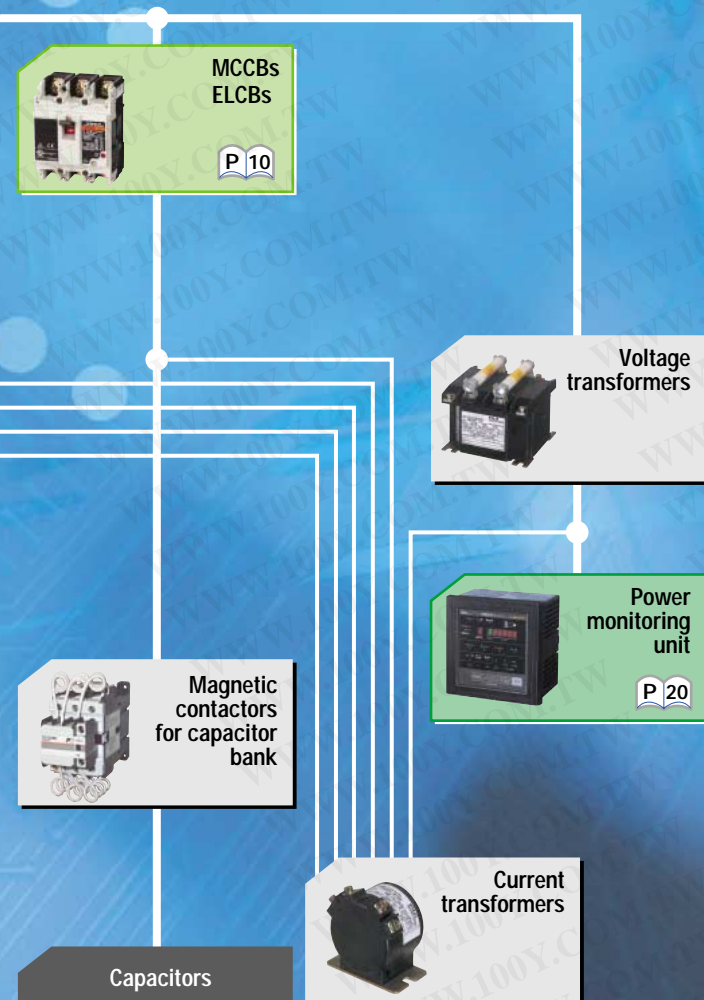

## CONTENTS

Magnetic Contactors and Starters	2
Manual Motor Starters and Contactors	6
Molded Case Circuit Breakers	10
Air Circuit Breakers	13
Pushbuttons, Selectors, Pilot Lights Command Switches	14
Time Delay Relays	17
Industrial Control Relays	18
Power Monitoring Unit	20

# Magnetic Contactors and Starters

Controlling energy to manage motors and machinery



## ■ Standard type non-reversing, open 03 to N1

Type	Contactors Starter	SC-03 SW-03/3H	SC-0 SW-0/3H	SC-05 SW-05/3H	SC-4-0 SW-4-0/3H	SC-4-1 SW-4-1/3H	SC-5-1 SW-5-1/3H	SC-N1 SW-N1/3H	
Max. motor capacity (kW)	200-240V 380-440V 500-550V 600-660V	2.5 4 4 4	3.5 5.5 5.5 5.5	3.5 5.5 5.5 5.5	4.5 7.5 7.5 7.5	5.5 11 11 7.5	5.5 11 11 7.5	7.5 15 15 11	
Operational current (A)	200-240V 380-440V 500-550V 600-660V	11 9 7 5	13 12 9 7	13 12 9 7	18 16 13 9	22 22 17 9	22 22 17 9	32 32 24 15	
Thermal current (A)		20	20	20	25	32	32	50	
Auxiliary contact arrangement		1NO 1NC	1NO 1NC	1NO+1NC 2NO, 2NC	1NO 1NC	1NO 1NC	1NO+1NC, 2NO 2NC, 2NO+2NC	2NO+2NC 4NO+4NC	
Durability (x 10 <sup>6</sup> operations)	Electrical 200V 400V	2 1.75	2 1.5	2 1.5	1.5 1	1.5 1	1.5 1	1.5 1	
	Mechanical	10	10	10	10	10	10	10	
Switching cycle per hour		1800	1800	1800	1800	1800	1800	1200	
Thermal overload relay	Standard type	TR-0N/3	TR-0N/3	TR-0N/3	TR-5-1N/3	TR-5-1N/3	TR-5-1N/3	TR-N2/3	
	Phase-loss protection	TK-0N	TK-0N	TK-0N	TK-5-1N	TK-5-1N	TK-5-1N	TK-N2	
Setting range (A)		0.1-0.15 0.13-0.2 0.15-0.24 0.2-0.3 0.24-0.36 0.3-0.45 0.36-0.54 0.48-0.72 0.64-0.96 0.8-1.2 0.95-1.45 1.4-2.2 1.7-2.6 2.2-3.4 2.8-4.2 4-6 5-8 6-9 7-11	0.1-0.15 0.13-0.2 0.15-0.24 0.2-0.3 0.24-0.36 0.3-0.45 0.36-0.54 0.48-0.72 0.64-0.96 0.8-1.2 0.95-1.45 1.4-2.2 1.7-2.6 2.2-3.4 2.8-4.2 4-6 5-8 6-9 7-11 9-13	0.1-0.15 0.13-0.2 0.15-0.24 0.2-0.3 0.24-0.36 0.3-0.45 0.36-0.54 0.48-0.72 0.64-0.96 0.8-1.2 0.95-1.45 1.4-2.2 1.7-2.6 2.2-3.4 2.8-4.2 4-6 5-8 6-9 7-11 9-13	0.1-0.15 0.13-0.2 0.15-0.24 0.2-0.3 0.24-0.36 0.3-0.45 0.36-0.54 0.48-0.72 0.64-0.96 0.8-1.2 0.95-1.45 1.4-2.2 1.7-2.6 2.2-3.4 2.8-4.2 4-6 5-8 6-9 7-11 9-13 12-18	0.1-0.15 0.13-0.2 0.15-0.24 0.2-0.3 0.24-0.36 0.3-0.45 0.36-0.54 0.48-0.72 0.64-0.96 0.8-1.2 0.95-1.45 1.4-2.2 1.7-2.6 2.2-3.4 2.8-4.2 4-6 5-8 6-9 7-11 9-13 12-18 16-22	0.1-0.15 0.13-0.2 0.15-0.24 0.2-0.3 0.24-0.36 0.3-0.45 0.36-0.54 0.48-0.72 0.64-0.96 0.8-1.2 0.95-1.45 1.4-2.2 1.7-2.6 2.2-3.4 2.8-4.2 4-6 5-8 6-9 7-11 9-13 12-18 16-22	0.1-0.15 0.13-0.2 0.15-0.24 0.2-0.3 0.24-0.36 0.3-0.45 0.36-0.54 0.48-0.72 0.64-0.96 0.8-1.2 0.95-1.45 1.4-2.2 1.7-2.6 2.2-3.4 2.8-4.2 4-6 5-8 6-9 7-11 9-13 12-18 16-22	4-6 5-8 6-9 7-11 9-13 12-18 18-26 24-36
	Dimensions (mm)	Contactors	43 x 81 x 80	43 x 81 x 80	53 x 81 x 80	53 x 81 x 81	53 x 81 x 81	64 x 81 x 81	74 x 87 x 96
	W x H x D	Starters	44 x 122 x 80	44 x 122 x 80	53 x 122 x 80	53 x 127 x 81	53 x 127 x 81	64 x 127 x 81	74 x 146 x 96
	Standard		IEC 60947-4-1, EN60947-4-1, VDE0660, TÜV, CE mark, CSA C22.2, UL508, CCC, NK, LR, BV, KR						

## ■ Standard type non-reversing, open N2 to N7







Type	Contact Starter	SC-N2 SW-N2/3H	SC-N2S SW-N2S/3H	SC-N3 SW-N3/3H	SC-N4 SW-N4/3H	SC-N5 SW-N5/3H	SC-N6 SW-N6/3H	SC-N7 SW-N7/3H
Max. motor capacity (kW)	200-240V 380-440V	11 18.5	15 22	18.5 30	22 40	30 55	37 60	45 75
AC-3	500-550V	18.5	25	37	37	55	60	75
IEC 60947-4-1	600-660V	15	22	30	37	55	60	90
Operational current (A)	200-240V	40	50	65	80	105	125	150
	380-440V	40	50	65	80	105	125	150
	500-550V	29	38	60	60	85	90	120
	600-660V	19	26	38	44	64	72	103
Thermal current (A)		60	80	100	135	150	150	200
Auxiliary contact arrangement		2NO+2NC 4NO+4NC	2NO+2NC 4NO+4NC	2NO+2NC 4NO+4NC	2NO+2NC 4NO+4NC	2NO+2NC 4NO+4NC	2NO+2NC 4NO+4NC	2NO+2NC 4NO+4NC
Durability (x 10 <sup>6</sup> operations)	Electrical 200V	1.5	2	2	1	0.8	0.6	1
	400V	1	1.5	1.5	0.8	0.7	0.5	0.8
	Mechanical	10	5	5	5	5	5	5
Switching cycle per hour		1200	1200	1200	1200	1200	1200	1200
Thermal overload relay	Standard type	TR-N2/3	TR-N3/3	TR-N3/3	TR-N5/3	TR-N5/3	TR-N6/3	TR-N7/3
	Phase-loss protection	TK-N2	TK-N3	TK-N3	TK-N5	TK-N5	TK-N6	TK-N7
Setting range (A)		4-6	7-11	7-11	18-26	18-26	45-65	45-65
		5-8	9-13	9-13	24-36	24-36	53-80	53-80
		6-9	12-18	12-18	28-40	28-40	65-95	65-95
		7-11	18-26	18-26	34-50	34-50	85-125	85-125
		9-13	24-36	24-36	45-65	45-65	110-160 *	110-160
		12-18	28-40	28-40	53-80	53-80		
		18-26	34-50	34-50		65-95		
		24-36	45-65	45-65		85-105		
		32-42		48-68 53-80 * 65-95 * 85-105 *				
Dimensions (mm)	Contactors	74 x 87 x 96	88 x 110 x 111	88 x 110 x 111	88 x 127 x 117	88 x 127 x 132	100 x 144 x 138	115 x 156 x 140
	Starters	74 x 146 x 96	88 x 177 x 111	88 x 177 x 111	88 x 189 x 117	88 x 189 x 132	100 x 225 x 138	155 x 237 x 140
Standard		IEC 60947-4-1, EN60947-4-1, VDE0660, TÜV, CE mark, CSA C22.2, UL508, CCC, NK, LR, BV, KR						







Note: \* Separate mounting only







## ■ Standard type non-reversing, open N8 to N16

Type	Contact Starter	SC-N8 SW-N8/3H	SC-N10 SW-N10/3H	SC-N11 SW-N11/3H	SC-N12 SW-N12/3H	SC-N14 SW-N14/3H	SC-N16 -	
Max. motor capacity (kW)	200-240V 380-440V	55 90	65 110	90 160	120 220	180 315	220 440	
AC-3	500-550V	130	132	160	250	400	500	
IEC 60947-4-1	600-660V	132	132	200	300	480	500	
Operational current (A)	200-240V	180	220	300	400	600	800	
	380-440V	180	220	300	400	600	800	
	500-550V	180	200	230	360	600	720	
	600-660V	150	150	230	360	600	630	
Thermal current (A)		260	260	350	450	660	800	
Auxiliary contact arrangement		2NO+2NC 4NO+4NC	2NO+2NC 4NO+4NC	2NO+2NC 4NO+4NC	2NO+2NC 4NO+4NC	2NO+2NC 4NO+4NC	2NO+2NC 4NO+4NC	
Durability (x 10 <sup>6</sup> operations)	Electrical 200V	1	1	1	0.7	0.6	0.3	
	400V	0.8	0.8	0.8	0.6	0.5	0.25	
	Mechanical	5	5	5	5	5	2.5	
Switching cycle per hour		1200	1200	1200	1200	1200	1200	
Thermal overload relay	Standard type	TR-N8/3	TR-N10/3	TR-N12/3	TR-N12/3	TR-N14/3	-	
	Phase-loss protection	TK-N8	TK-N10	TK-N12	TK-N12	TK-N14	-	
Setting range (A)		65-95	85-125	110-160	110-160	240-360	-	
		85-125	110-160	125-185	125-185	300-450		
		110-160	125-185	160-240	160-240	400-600		
		125-185	160-240	200-300	200-300 240-360 300-450			
Dimensions (mm)	Contactors	138 x 209 x 174	138 x 209 x 174	148 x 240 x 195	148 x 240 x 195	290 x 332 x 327	290 x 332 x 327	
	Starters	138 x 305 x 174	138 x 287 x 174	148 x 360 x 195	148 x 360 x 195	290 x 463 x 327	-	
Standard		IEC 60947-4-1, EN60947-4-1, VDE0660, TÜV, CE mark, CSA C22.2, UL508, CCC, NK, LR, BV, KR						

## Optional accessories

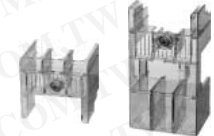
Optional unit	Auxiliary contact block			Operation counter	Coil surge suppression unit	Main circuit surge suppression unit
	All contacts are bifurcated contacts so that the minimum voltage current is 5V DC, 3mA.			This unit indicates the number of contactor on-off operations to ensure easy maintenance and inspection.	This unit absorbs coil surge voltage due to contactor on-off operation.	This unit prevents misoperation of electronic equipment due to surge voltage generated from motor when contactor is open or closed.
Type	<b>4-pole SZ-A</b> Front mounting	<b>2-pole SZ-A</b>	<b>Single-pole SZ-AS</b> Side mounting	<b>SZ-J</b>	<b>SZ-Z</b>	<b>SZ-ZM</b> Front mounting      Side mounting
						
Used with	SC-03 to N3		SC-03 to N16	SC-03 to N3	SC-03 to N4 SC-03/G to SC-N3/G	SC-03 to N3      SC-03 to N3

Optional unit	Mechanical interlock unit and power connection kit for reversing		Coil drive unit for IC output		3-pole parallel connection kit	Base unit for separate mounting	Dial cover
	This unit is used to interlock two contactors for reversing.		This unit controls on-off operation for contactor by the DC output of electronic equipment.		This kit modifies a 3-pole contactors to a single-pole contactor for resistive load.	This unit is used when thermal relay is required to mount independently.	For protection against the current setting being changed in error.
Type	<b>SZ-RM</b>	<b>SZ-RW</b>	<b>SZ-CD</b> Top mounting	<b>SZ-CD</b> Side mounting	<b>SZ-SP</b>	<b>SZ-H</b>	<b>SZ-DA</b>
							
Used with	SC-03 to N3	SC-03 to N3	SC-03 to N3	SC-N1 to N12	SC-03 to N16	TR-0N to N3	TR-0N to N14

Optional unit	Trip indicator	Terminal cover		Insulation barrier	Live-section cover	Off-delay release unit
	This unit indicates thermal relay tripping status.	This covers conform to DIN 57106 and VDE 0106 Teil 100.		This unit prevents accidental short-circuits caused by metallic objects falling onto the terminals.	This cover prevents exposure of the live section for increasing safety.	This unit prevents circuit opening due to instantaneous voltage drop.
Type	<b>SZ-L</b>	<b>SZ-T</b> □, □T, <b>SZ-W</b> □T		<b>SZ-B</b>	<b>SZ-□J, W□J</b> <b>SZ-J</b> □, <b>JW</b> □	<b>SZ-DE</b> □ <b>SZ-□DE</b>
						
Used with	TR-0N to N14	SC-03 to N12 SW-03 to N12	TR-0N to N3 TR-N2H, N3H, N6H	SC-N4 to N12 SW-N4 to N12 TR-N6H, N10H, N12H	SC-03 to N12 SW-03 to N12	SC-03/G to N14

## ■ Versions

### Starters with on-off and RESET pushbuttons

- Compact and simple operation – Provided with ON-OFF and reset pushbuttons, hence best suited for direct-on-line starting.
- Superior motor protection – Built-in highly reliable thermal overload relay is designed to give motor complete protection against overcurrent.
- Long service life – Hyperfine silver alloy contacts performance and a long electrical life.



Max. motor capacity (kW) Single-phase	3-phase		Auxiliary contact	With on-off/reset pushbutton Type
	200/240V	380/440V		
0.4	2.5	4	1NO	SW-03P/3H
0.5	3.5	5.5	1NO	SW-0P/3H
0.5	3.5	5.5	1NO+1NC	SW-05P/3H
0.6	4.5	7.5	1NO	SW-4-0P/3H
0.8	5.5	11	1NO	SW-4-1P/3H
0.8	5.5	11	1NO+1NC	SW-5-1P/3H
1.2	7.5	15	2NO+2NC	SW-N1PB/3H
1.7	11	18.5	2NO+2NC	SW-N2PB/3H
–	15	22	2NO+2NC	SW-N2SPB/3H
–	18.5	30	2NO+2NC	SW-N3PB/3H
–	22	40	2NO+2NC	SW-N4PB/3H
–	30	55	2NO+2NC	SW-N5PB/3H
–	37	60	2NO+2NC	SW-N6PB/3H
–	55	90	2NO+2NC	SW-N8PB/3H
–	65	110	2NO+2NC	SW-N10PB/3H

#### Coil voltage \*

##### • SW-03P to 5-1P, N1PB to N4PB

24V 50Hz / 24-26V 60Hz  
48V 50Hz / 48-52V 60Hz  
100V 50Hz / 100-110V 60Hz  
100-110V 50Hz / 110-120V 60Hz  
110-120V 50Hz / 120-130V 60Hz  
200V 50Hz / 200-220V 60Hz  
200-220V 50Hz / 220-240V 60Hz  
220-240V 50Hz / 240-260V 60Hz  
346-380V 50Hz / 380-420V 60Hz  
380-400V 50Hz / 400-440V 60Hz  
415-440V 50Hz / 440-480V 60Hz  
480-500V 50Hz / 500-550V 60Hz

##### • SW-N5PB to N10PB

AC DC  
24-25V 50/60Hz 24V  
48-50V 50/60Hz 48V  
100-127V 50/60Hz 100-120V  
200-250V 50/60Hz 200-240V  
265-347V 50/60Hz  
380-450V 50/60Hz  
460-575V 50/60Hz

\* Other coil voltages between 24V and 600V AC are available.

### Definite purpose contactors and starters

- Small size, light weight
- Budget priced
- Long service life – The contacts are self-cleaning by a scrubbing section during operation and are made of silver alloy.
- Highly reliable operating coil – Pick up voltage 75% of rated voltage
- Self-lifting terminals make it easy to wire.



Motor capacity (kW) AC-3 3-phase	Operational current (A)		Auxiliary contact	Non-reversing Open Type
	200/240V	380/440V		
3	2.5	20	1NO, 1NC	FC-0UL
3.5	4.5	20	1NO, 1NC	FC-0SUL
5.5	5.5	30	1NO+1NC *1	FC-1UL
7.5	7.5	30	1NO+1NC *1	FC-1SUL
11	11	40	1NO+1NC *1	FC-2SUL
15	18.5	60	1NO+1NC *1	FC-3UL
18.5	30	80	1NO+1NC *1	FC-4UL
1.5	–	8	1NO, 1NC	FC-0A
3.0	2.5	20	1NO, 1NC	FC-0TUL
3.5	4.5	20	1NO, 1NC	FC-0STUL
3.0	2.5	20	1NO, 1NC	FC-0/GUL
3.5	4.5	20	1NO, 1NC	FC-0S/GUL
3.0	2.5	20	1NO, 1NC	FC-0/TGUL
3.5	4.5	20	1NO, 1NC	FC-0S/TGUL
1.5	–	8	1NO, 1NC	FC-0A/G

#### Coil voltage \*

##### • FC-0/UL to 4UL

24V 50Hz / 24-26V 60Hz  
48V 50Hz / 48-52V 60Hz  
100V 50Hz / 100-110V 60Hz  
100-110V 50Hz / 110-120V 60Hz  
110-120V 50Hz / 120-130V 60Hz  
200V 50Hz / 200-220V 60Hz  
200-220V 50Hz / 220-240V 60Hz  
220-240V 50Hz / 240-260V 60Hz  
346-380V 50Hz / 380-420V 60Hz  
380-400V 50Hz / 400-440V 60Hz  
415-440V 50Hz / 440-480V 60Hz

##### • FC-0/GUL to 0A/G

24V DC  
48V DC  
60V DC  
100V DC  
110V DC  
200V DC  
220V DC

\*1 : Auxiliary contact arrangement 2NO or 2NC is available.

\* Other coil voltages between 24V and 440V AC are available.

### Standard type industrial relay

- Employing of bifurcated contact assures an increase of high contact reliability in low-level circuit use (5V, 3mA)
- Variety of optional function units: Auxiliary contact block, off-delay release unit, coil surge suppression unit and operation counter
- Snap-on 35mm rail mounting available
- UL, CSA, TÜV, BV and Lloyd approved



Type	SH-4 4-pole, 8-pole	SH-5 5-pole	SH-4H 4-pole, 8-pole	SH-5H 5-pole
Contact	Bifurcated		Single	
Rated thermal current (A)	10		10	
Make and break capacity (A)	110V AC	60	60	
	220V AC	30	60	
	440V AC	15	40	
	550V AC	12	40	
Rated operational current (A)	Ind.	Res.	Ind.	Res.
	110V AC	6	10	10
	220V AC	3	8	10
	440V AC	1.5	5	4
	550V AC	1.2	5	4
	24V DC	3	5	5
	48V DC	1.5	3	1.5
	110V DC	0.55	2.5	0.7
	220V DC	0.27	1	0.27
	Coil voltage *	24V 50Hz / 24-26V / 60Hz, 48V 50Hz / 48-52V / 60Hz, 100V 50Hz / 100-110V / 60Hz, 110-120V 50Hz / 120-130V / 60Hz, 200V 50Hz / 200-220V / 60Hz		220-240V 50Hz / 240-260V / 60Hz, 346-380V 50Hz / 380-420V / 60Hz, 380-400V 50Hz / 400-440V / 60Hz, 415-440V 50Hz / 440-480V / 60Hz, 480-500V 50Hz / 500-550V / 60Hz
Contact arrangement	4-pole : 4NO, 3NO+1NC, 2NO+2NC 8-pole : 8NO, 7NO+1NC, 6NO+2NC, 5NO+3NC, 4NO+4NC 5-pole : 5NO, 4NO+1NC, 3NO+2NC, 2NO+3NC, 1NO+4NC, 5NC			

\* Other coil voltages between 24V and 600V AC are available.

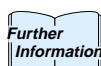

See page 01/1 of D & C catalog 19th Edition.

# Manual Motor Starters and Contactors

## Molded case circuit breaker and thermal overload relay functions integrated into highly compact unit



DUO series

### ■ MMSs / 32AF

Adjustable thermal-magnetic trip type	Standard breaking capacity		High breaking capacity																			
Instantaneous trip type	BM3RSB-□		BM3RHB-□																			
Number of poles	3		3																			
Handle type	Rocker		Rotary																			
Rated current I <sub>e</sub> (A)	0.16 to 32																					
Rated operational voltage U <sub>e</sub> (V)	200 to 690																					
Rated frequency (Hz)	50/60																					
Rated insulation voltage U <sub>i</sub> (V)	690																					
Rated impulse withstand voltage U <sub>imp</sub> (kV)	6																					
Utilization IEC 60947-2 Circuit breaker category IEC 60947-4-1 Motor starter	Category A AC-3																					
Trip class IEC 60947-4-1 *	10																					
Instantaneous trip characteristic	13 x I <sub>e</sub> maximum																					
Power loss (total of 3-pole)	7W: I <sub>n</sub> =0.16 to 25A 8.5W: I <sub>n</sub> =32A																					
Durability (operations)	Mechanical 100,000: I <sub>n</sub> =0.16 to 25A 70,000: I <sub>n</sub> =32A Electrical 100,000: I <sub>n</sub> =0.16 to 25A 70,000: I <sub>n</sub> =32A																					
Max. operations per hour (motor start-up)	25																					
Phase-loss protection	Provided																					
Trip indicator / Test trip function	Provided																					
Rated breaking capacity (kA)	Adjustable current range Code I <sub>e</sub> : Min.–Max. (A)	240V/230V		415V/400V		460V/440V		500V		690V/600V		240V/230V		415V/400V		460V/440V		500V		690V/600V		
		I <sub>cu</sub>	I <sub>cs</sub>	I <sub>cu</sub>	I <sub>cs</sub>	I <sub>cu</sub>	I <sub>cs</sub>	I <sub>cu</sub>	I <sub>cs</sub>	I <sub>cu</sub>	I <sub>cs</sub>	I <sub>cu</sub>	I <sub>cs</sub>	I <sub>cu</sub>	I <sub>cs</sub>	I <sub>cu</sub>	I <sub>cs</sub>	I <sub>cu</sub>	I <sub>cs</sub>	I <sub>cu</sub>	I <sub>cs</sub>	
IEC 60947-2	P16	0.1-0.16	100	100	100	100	100	100	100	100	100	100	100	100	100	100	100	100	100	100	100	
	P25	0.16-0.25	100	100	100	100	100	100	100	100	100	100	100	100	100	100	100	100	100	100	100	
	P40	0.25-0.4	100	100	100	100	100	100	100	100	100	100	100	100	100	100	100	100	100	100	100	
	P63	0.4-0.63	100	100	100	100	100	100	100	100	100	100	100	100	100	100	100	100	100	100	100	
	001	0.63-1	100	100	100	100	100	100	100	100	100	100	100	100	100	100	100	100	100	100	100	
	1P6	1-1.6	100	100	100	100	100	100	100	100	100	100	100	100	100	100	100	100	100	100	100	
	2P5	1.6-2.5	100	100	100	100	100	100	100	100	3	2	100	100	100	100	100	100	100	100	8	6
	004	2.5-4	100	100	100	100	100	100	100	100	3	2	100	100	100	100	100	100	100	100	8	6
	6P3	4-6.3	100	100	100	100	50	38	50	38	3	2	100	100	100	100	100	100	100	100	6	5
	010	6.3-10	100	100	100	100	15	11	10	8	3	2	100	100	100	100	50	38	50	38	6	5
	013	9-13	100	100	50	38	10	8	6	5	3	2	100	100	100	100	50	37	42	32	6	5
	016	11-16	100	100	25	19	10	8	6	5	3	2	100	100	50	38	35	27	10	8	4	3
	020	14-20	50	38	25	19	10	8	6	5	3	2	100	100	50	38	35	27	10	8	4	3
	025	19-25	50	38	25	19	10	8	6	5	3	2	100	100	50	38	35	27	10	8	4	3
032	24-32	50	38	25	19	10	8	6	5	3	2	100	100	50	38	35	27	10	8	4	3	
040	28-40	–	–	–	–	–	–	–	–	–	–	–	–	–	–	–	–	–	–	–	–	
050	35-50	–	–	–	–	–	–	–	–	–	–	–	–	–	–	–	–	–	–	–	–	
063	45-63	–	–	–	–	–	–	–	–	–	–	–	–	–	–	–	–	–	–	–	–	
Dimensions (mm) W x H x D	45 x 90 x 66						45 x 90 x 79															
Standard	IEC 60947-1, 60947-2, 60947-4-1, UL 508, CSA C22.2 No.14, TÜV, CCC																					

Note: \* Adjustable thermal-magnetic trip type only

## ■ MMSs / 63AF

Adjustable thermal-magnetic trip type		Standard breaking capacity												High breaking capacity											
Instantaneous trip type		<b>BM3VSB-</b> □												<b>BM3VHB-</b> □											
		<b>BM3VSBK-</b> □												<b>BM3VHBK-</b> □											
Number of poles		3												3											
Handle type		Rotary												Rotary											
Rated current I <sub>e</sub> (A)		10 to 63																							
Rated operational voltage U <sub>e</sub> (V)		200 to 690																							
Rated frequency (Hz)		50/60																							
Rated insulation voltage U <sub>i</sub> (V)		1000																							
Rated impulse withstand voltage U <sub>imp</sub> (kV)		8																							
Utilization category IEC 60947-2		Circuit breaker												Category A											
Utilization category IEC 60947-4-1		Motor starter												AC-3											
Trip class IEC 60947-4-1 *		10																							
Instantaneous trip characteristic		13 x I <sub>e</sub> maximum																							
Power loss (total of 3-pole)		11W: I <sub>n</sub> =10 to 32A 15W: I <sub>n</sub> =40 to 50A 17W: I <sub>n</sub> =63A																							
Durability (operations)		Mechanical 50,000 Electrical 25,000																							
Max. operations per hour (motor start-up)		25																							
Phase-loss protection		Provided																							
Trip indicator / Test trip function		Provided																							
Rated breaking capacity (kA)	Adjustable current range	240V/		415V/		460V/		500V		690V/		240V/		415V/		460V/		500V		690V/					
	Code I <sub>e</sub> : Min.-Max. (A)	230V		400V		440V				600V		230V		400V		440V				600V					
IEC 60947-2		I <sub>cu</sub>	I <sub>cs</sub>	I <sub>cu</sub>	I <sub>cs</sub>	I <sub>cu</sub>	I <sub>cs</sub>	I <sub>cu</sub>	I <sub>cs</sub>	I <sub>cu</sub>	I <sub>cs</sub>	I <sub>cu</sub>	I <sub>cs</sub>	I <sub>cu</sub>	I <sub>cs</sub>	I <sub>cu</sub>	I <sub>cs</sub>	I <sub>cu</sub>	I <sub>cs</sub>	I <sub>cu</sub>	I <sub>cs</sub>				
Replace the □ mark in the type number by current range codes.	<b>P16</b>	0.1-0.16	–	–	–	–	–	–	–	–	–	–	–	–	–	–	–	–	–	–	–				
	<b>P25</b>	0.16-0.25	–	–	–	–	–	–	–	–	–	–	–	–	–	–	–	–	–	–	–				
	<b>P40</b>	0.25-0.4	–	–	–	–	–	–	–	–	–	–	–	–	–	–	–	–	–	–	–				
	<b>P63</b>	0.4-0.63	–	–	–	–	–	–	–	–	–	–	–	–	–	–	–	–	–	–	–				
	<b>001</b>	0.63-1	–	–	–	–	–	–	–	–	–	–	–	–	–	–	–	–	–	–	–				
	<b>1P6</b>	1-1.6	–	–	–	–	–	–	–	–	–	–	–	–	–	–	–	–	–	–	–				
	<b>2P5</b>	1.6-2.5	–	–	–	–	–	–	–	–	–	–	–	–	–	–	–	–	–	–	–				
	<b>004</b>	2.5-4	–	–	–	–	–	–	–	–	–	–	–	–	–	–	–	–	–	–	–				
	<b>6P3</b>	4-6.3	–	–	–	–	–	–	–	–	–	–	–	–	–	–	–	–	–	–	–				
	<b>010</b>	6.3-10	100	100	100	100	15	12	10	8	4	3	100	100	100	100	50	38	50	38	6	5			
	<b>013</b>	9-13	100	100	50	38	10	8	6	5	4	3	100	100	100	100	50	38	42	32	6	5			
	<b>016</b>	11-16	100	100	25	19	10	8	6	5	4	3	100	100	50	38	50	38	12	9	5	4			
	<b>020</b>	14-20	50	38	25	19	10	8	6	5	4	3	100	100	50	38	50	38	12	9	5	4			
	<b>025</b>	19-25	50	38	25	19	10	8	6	5	4	3	100	100	50	38	35	27	12	9	5	4			
<b>032</b>	24-32	50	38	25	19	10	8	6	5	4	3	100	100	50	38	35	27	10	8	5	4				
<b>040</b>	28-40	50	38	25	19	10	8	6	5	4	3	100	100	50	38	35	27	10	8	5	4				
<b>050</b>	35-50	50	38	25	19	10	8	6	5	4	3	100	100	50	38	35	27	10	8	5	4				
<b>063</b>	45-63	50	38	25	19	10	8	6	5	4	3	100	100	50	38	35	27	10	8	5	4				
Dimensions (mm) W x H x D		55 x 110 x 96																							
Standard		IEC 60947-1, 60947-2, 60947-4-1, UL 508, CSA C22.2 No.14, TÜV, CCC																							

Note: \* Adjustable thermal-magnetic trip type only

## ■ Contactors / SC-M, SC-E

Contactor	Non-reversing Reversing	SC-M01 SC-M01RM	SC-M02 SC-M02RM	SC-E02 SC-E02RM	SC-E03 SC-E03RM	SC-E04 SC-E04RM	SC-E05 SC-E05RM	SC-E1 SC-E1RM
Motor capacity 3-phase AC-3 (kW)	200-240V 380-440V	1.5 2.2	3 4	2.2 4	3 5.5	4 7.5	5.5 11	7.5 15
Rated operational current AC-3 (A)	200-240V 380-440V	6 6	9 9	9 9	12 12	18 18	25 25	32 32
Rated thermal current AC-1 (A)		20	20	20	20	25	32	50
Auxiliary contact Non-reversing		1NO, 1NC	1NO, 1NC	–	–	–	–	–
Dimensions (mm) W x H x D	AC operated Non-reversing DC operated	45 x 48 x 56 45 x 48 x 68		43 x 81 x 81 43 x 81 x 108			54 x 90 x 96 54 x 90 x 121.5	
Standard		IEC 60947-4-1, EN 60947-4-1, VDE 0660, UL 508, CSA C22.2						
Thermal overload relay (standard type)		TK-M0	TK-M0	TK-E02	TK-E02	TK-E02	TK-E02	TK-E2
Ampere setting range (A)		0.11-0.17 0.17-0.26 0.26-0.43 0.43-0.65 0.65-1.0 0.85-1.3 1.1-1.6 1.35-2.0 1.7-2.4 2.2-3.2 2.5-4.0 3.0-4.7 4.0-6.3	0.11-0.17 0.17-0.26 0.26-0.43 0.43-0.65 0.65-1.0 0.85-1.3 1.1-1.6 1.35-2.0 1.7-2.4 2.2-3.2 2.5-4.0 3.0-4.7 4.0-6.3	0.1-0.15 0.13-0.2 0.15-0.24 0.2-0.3 0.24-0.36 0.3-0.45 0.36-0.54 0.48-0.72 0.64-0.96 0.8-1.2 0.95-1.45 1.4-2.2 1.7-2.6 2.2-3.4 2.8-4.2 4-6 5-8 6-9 7-11	0.1-0.15 0.13-0.2 0.15-0.24 0.2-0.3 0.24-0.36 0.3-0.45 0.36-0.54 0.48-0.72 0.64-0.96 0.8-1.2 0.95-1.45 1.4-2.2 1.7-2.6 2.2-3.4 2.8-4.2 4-6 5-8 6-9 7-11 9-13	0.1-0.15 0.13-0.2 0.15-0.24 0.2-0.3 0.24-0.36 0.3-0.45 0.36-0.54 0.48-0.72 0.64-0.96 0.8-1.2 0.95-1.45 1.4-2.2 1.7-2.6 2.2-3.4 2.8-4.2 4-6 5-8 6-9 7-11 9-13 12-18	0.1-0.15 0.13-0.2 0.15-0.24 0.2-0.3 0.24-0.36 0.3-0.45 0.36-0.54 0.48-0.72 0.64-0.96 0.8-1.2 0.95-1.45 1.4-2.2 1.7-2.6 2.2-3.4 2.8-4.2 4-6 5-8 6-9 7-11 9-13 12-18 16-22 20-25	4-6 5-8 6-9 7-11 9-13 12-18 18-26 24-36
Dimensions W x H x D (mm)		45 x 68.5 x 53		53 x 60.5 x 80.5			54 x 78.5 x 97	
Standard		IEC 60947-1, EN 60947-4-1, VDE 0660, UL 508, CSA C22.2						

Contactor	Non-reversing Reversing	SC-E2 SC-E2RM	SC-E2S SC-E2SRM	SC-E3 SC-E3RM	SC-E4 SC-E4RM	SC-E5 SC-E5RM	SC-E6 SC-E6RM	SC-E7 SC-E7RM
Motor capacity 3-phase AC-3 (kW)	200-240V 380-440V	11 18.5	15 22	18.5 30	22 40	30 55	37 60	45 75
Rated operational current AC-3 (A)	200-240V 380-440V	40 40	50 50	68 65	80 80	105 105	125 125	150 150
Rated thermal current AC-1 (A)		60	65	100	105	150	150	200
Auxiliary contact Non-reversing		–	–	–	–	2NO+2NC	2NO+2NC	2NO+2NC
Dimensions (mm) W x H x D	AC operated Non-reversing DC operated	54 x 90 x 96 54 x 90 x 121.5		67 x 112 x 111 67 x 112 x 130		88 x 155 x 132	100 x 169 x 138	115 x 175 x 140
Standard		IEC 60947-4-1, EN 60947-4-1, VDE 0660, UL 508, CSA C22.2						
Thermal overload relay (standard type)		TK-E2	TK-E2	TK-E3	TK-E3	TK-E5	TK-E6	TK-E6
Ampere setting range (A)		4-6 5-8 6-9 7-11 9-13 12-18 18-26 24-36 32-42	4-6 5-8 6-9 7-11 9-13 12-18 18-26 24-36 32-42 40-50 44-54	7-11 9-13 12-18 18-26 24-36 28-40 34-50 45-65 48-68	7-11 9-13 12-18 18-26 24-36 28-40 34-50 45-65 48-68 64-80	18-26 24-36 28-40 34-50 45-65 65-95 85-105	45-65 53-80 65-95 85-125	45-65 53-80 65-95 85-125 110-160
Dimensions W x H x D (mm)		54 x 78.5 x 97		68 x 89.5 x 107.5	76.5 x 105 x 106	100 x 122 x 123		
Standard		IEC 60947-1, EN 60947-4-1, VDE 0660, UL 508, CSA C22.2						

## Protective coordination between MMSs and contactors (Individuation)

IEC 60947-4-1 Type 1 The rated conditional short-circuit current  $I_q=50kA/240V$  AC, 415V AC

Motor capacity and full load current 3-phase				Manual motor starter		Magnetic contactor			Rated operational current AC-3 (A)		
200-240V AC		380-415V AC		Type	Adjustable current range (A)	Type			M series	E series	SC series
Capacity (kW)	Current (A)	Capacity (kW)	Current (A)			M series	E series	SC series			
0.03	0.24	0.06	0.21	BM3RSB-P25	0.16 to 0.25	SC-M01	SC-E02	SC-03	6	9	9
0.06	0.37	0.09	0.31	BM3RSB-P40	0.25 to 0.4	SC-M01	SC-E02	SC-03	6	9	9
–	–	0.18	0.63	BM3RSB-P63	0.4 to 0.63	SC-M01	SC-E02	SC-03	6	9	9
0.12	0.72	0.18	0.63	BM3RSB-001	0.63 to 1.0	SC-M01	SC-E02	SC-03	6	9	9
–	–	0.25	0.8	BM3RSB-001	0.63 to 1.0	SC-M01	SC-E02	SC-03	6	9	9
0.25	1.4	0.37	1.1	BM3RSB-1P6	1.0 to 1.6	SC-M01	SC-E02	SC-03	6	9	9
–	–	0.55	1.5	BM3RSB-1P6	1.0 to 1.6	SC-M01	SC-E02	SC-03	6	9	9
0.37	2	0.75	1.9	BM3RSB-2P5	1.6 to 2.5	SC-M01	SC-E02	SC-03	6	9	9
–	–	1.1	2.5	BM3RSB-004	2.5 to 4.0	SC-M01	SC-E02	SC-03	6	9	9
0.75	3.6	1.5	3.4	BM3RSB-004	2.5 to 4.0	SC-M01	SC-E02	SC-03	6	9	9
–	–	2.2	4.5	BM3RSB-6P3	4.0 to 6.3	SC-M01	SC-E02	SC-03	6	9	9
1.5	6.1	3	6.5	BM3RSB-010	6.3 to 10	SC-M02	SC-E02	SC-03	9	9	9
2.2	9.2	4	8	BM3RSB-010	6.3 to 10	SC-M02	SC-E02	SC-03	9	9	9
3	12	5.5	11	BM3RSB-013	9 to 13		SC-E03	SC-0 or SC-05		12	12
4	16	7.5	14	BM3RHB-020	14 to 20		SC-E04	SC-4-0		18	16
5.5	22	11	21	BM3RHB-025	19 to 25		SC-E05	SC-4-1 or SC-5-1		25	22
7.5	29	15	28	BM3RHB-032	24 to 32		SC-E1	SC-N1		32	32
				BM3VHB-032							
11	38	18.5	35	BM3VHB-040	28 to 40		SC-E2	SC-N2		40	40
15	50	22	45	BM3VHB-050	35 to 50		SC-E2S	SC-N2S		50	50

Note: • The full-load current of each three-phase motor is a reference value. Check the actual full-load current of the motor before use.

## Protective coordination between MMSs and contactors (Combination starters)

IEC 60947-4-1 Type 1 The rated conditional short-circuit current  $I_q=50kA/240V$  AC, 415V AC

Motor capacity and full load current 3-phase				Manual motor starter		Magnetic contactor		Link module	Base plate
200-240V AC		380-415V AC		Type	Adjustable current range (A)	Type	Rated operational current (AC-3) (A)		
Capacity (kW)	Current (A)	Capacity (kW)	Current (A)					*1	
0.03	0.24	0.06	0.21	BM3RSB-P25	0.16 to 0.25	SC-M01	6	BZ0LRC09AA	(BZ0BP22A)
						SC-E02	9	BZ0LRE22AA	BZ0BP22A
0.06	0.37	0.09	0.31	BM3RSB-P40	0.25 to 0.4	SC-M01	6	BZ0LRC09AA	(BZ0BP22A)
						SC-E02	9	BZ0LRE22AA	BZ0BP22A
–	–	0.18	0.63	BM3RSB-P63	0.4 to 0.63	SC-M01	6	BZ0LRC09AA	(BZ0BP22A)
						SC-E02	9	BZ0LRE22AA	BZ0BP22A
0.12	0.72	0.18	0.63	BM3RSB-001	0.63 to 1.0	SC-M01	6	BZ0LRC09AA	(BZ0BP22A)
						SC-E02	9	BZ0LRE22AA	BZ0BP22A
–	–	0.25	0.8	BM3RSB-001	0.63 to 1.0	SC-M01	6	BZ0LRC09AA	(BZ0BP22A)
						SC-E02	9	BZ0LRE22AA	BZ0BP22A
0.25	1.4	0.37	1.1	BM3RSB-1P6	1.0 to 1.6	SC-M01	6	BZ0LRC09AA	(BZ0BP22A)
						SC-E02	9	BZ0LRE22AA	BZ0BP22A
–	–	0.55	1.5	BM3RSB-1P6	1.0 to 1.6	SC-M01	6	BZ0LRC09AA	(BZ0BP22A)
						SC-E02	9	BZ0LRE22AA	BZ0BP22A
0.37	2	0.75	1.9	BM3RSB-2P5	1.6 to 2.5	SC-M01	6	BZ0LRC09AA	(BZ0BP22A)
						SC-E02	9	BZ0LRE22AA	BZ0BP22A
–	–	1.1	2.5	BM3RSB-004	2.5 to 4.0	SC-M01	6	BZ0LRC09AA	(BZ0BP22A)
						SC-E02	9	BZ0LRE22AA	BZ0BP22A
0.75	3.6	1.5	3.4	BM3RSB-004	2.5 to 4.0	SC-M01	6	BZ0LRC09AA	(BZ0BP22A)
						SC-E02	9	BZ0LRE22AA	BZ0BP22A
–	–	2.2	4.5	BM3RSB-6P3	4.0 to 6.3	SC-M01	6	BZ0LRC09AA	(BZ0BP22A)
						SC-E02	9	BZ0LRE22AA	BZ0BP22A
1.5	6.1	3	6.5	BM3RSB-010	6.3 to 10	SC-M02	9	BZ0LRC09AA	(BZ0BP22A)
						SC-E02	9	BZ0LRE22AA	BZ0BP22A
2.2	9.2	4	8	BM3RSB-010	6.3 to 10	SC-M02	9	BZ0LRC09AA	(BZ0BP22A)
						SC-E02	9	BZ0LRE22AA	BZ0BP22A
3	12	5.5	11	BM3RSB-013	9 to 13	SC-E03	12	BZ0LRE22AA	BZ0BP22A
4	16	7.5	14	BM3RHB-020	14 to 20	SC-E04	18	BZ0LRE22AA	BZ0BP22A
5.5	22	11	21	BM3RHB-025	19 to 25	SC-E05	25	BZ0LRE22AA	BZ0BP22A
7.5	29	15	28	BM3RHB-032	24 to 32	SC-E1	32	BZ0LRE32AA	BZ0BP32A
				BM3VHB-032				BZ0LVE51AA	BZ0BPV51A
11	38	18.5	35	BM3VHB-040	28 to 40	SC-E2	40	BZ0LVE51AA	BZ0BPV51A
15	50	22	45	BM3VHB-050	35 to 50	SC-E2S	50	BZ0LVE51AA	BZ0BPV51A

Notes: • The full-load current of each three-phase motor is a reference value. Check the actual full-load current of the motor before use.

• The above table shows combinations with AC operated type magnetic contactors. The link module will differ if the magnetic contactor is a DC operated type.

\*1 Use the base plate type in ( ) when you use the base plate.



See page 02/1 of D & C catalog 19th Edition.

# Molded Case Circuit Breakers

Compact, modular units help to reduce panel design and manufacturing costs



**BW253S0**



**EA103C-CE**



**SA203C-CE**

## ■ BW series/2, 3-pole

**NEW**

Frame	100A	160A		250A		100A	
Pole	3	2	3	2	3	2	3
Type	<b>BW103E0</b>	<b>BW162E0</b>	<b>BW163E0</b>	<b>BW252E0</b>	<b>BW253E0</b>	<b>BW102S0</b>	<b>BW103S0</b>
Rated current (A)	15, 20, 25, 30 40, 50, 60, 75 80, 100	100, 125, 150, 160		175, 200, 225, 250		15, 20, 25, 30, 40, 50, 60, 75 80, 100	
Rated interrupting capacity (kA)	415V AC 15/8 380V AC 18/9 230V AC 25/13	18/9	18/9	18/9	18/9	30/8 30/15	30/8 30/15
IEC 60947-2 (Icu/lcs)	230V AC 25/13	25/13	25/13	25/13	25/13	50/25	100/50

Frame	160A				250A			
Pole	2	3	2	3	2	3	2	3
Type	<b>BW162J0</b>	<b>BW163J0</b>	<b>BW162S0</b>	<b>BW163S0</b>	<b>BW252J0</b>	<b>BW253J0</b>	<b>BW252S0</b>	<b>BW253S0</b>
Rated current (A)	100, 125, 150, 160		100, 125, 150, 160		175, 200, 225, 250		175, 200, 225, 250	
Rated interrupting capacity (kA)	415V AC 25/13 380V AC 25/13 230V AC 50/25		36/18 36/18 85/43		25/13 25/13 50/25		36/18 36/18 85/43	

## ■ E series/2, 3-pole

Frame	30A		50A		60A	
Pole	2	3	2	3	2	3
Type	<b>EA32AC□-CE</b>	<b>EA33AC□-CE</b>	<b>EA52C□-CE</b>	<b>EA53C□-CE</b>	<b>EA62C□-CE</b>	<b>EA63C□-CE</b>
Rated current (A)	3, 5, 10, 15, 20, 30		5, 10, 15, 20, 30, 40, 50		60	
Rated interrupting capacity (kA)	415V AC 1.5/1 380V AC 1.5/1 230V AC 2.5/2		2.5/2 2.5/2 5/3		2.5/2 2.5/2 5/3	

Frame	100A		225A		400A	
Pole	2	3	2	3	2	3
Type	<b>EA102C□-CE</b>	<b>EA103C□-CE</b>	<b>EA202C□-CE</b>	<b>EA203C□-CE</b>	<b>EA402C□-CE</b>	<b>EA403C□-CE</b>
Rated current (A)	50, 60, 75, 100		125, 150, 175, 200, 225		250, 300, 350, 400	
Rated interrupting capacity (kA)	415V AC 10/5 380V AC 10/5 230V AC 25/13		18/5 18/5 35/18		25/13 25/13 35/18	

Frame	600A	800A
Pole	3	3
Type	<b>EA603C</b> □-CE	<b>EA803</b> □-CE
Rated current (A)	500, 600	700, 800
Rated interrupting capacity (kA)	415V AC 35/18 380V AC 35/18	35/18 35/18
IEC 60947-2 (Icu/Ics)	230V AC 50/25	50/25

## ■ S series/2, 3-pole

Frame	30A		50A			
Pole	2	3	2	3	2	3
Type	<b>SA32C</b> □-CE	<b>SA33C</b> □-CE	<b>SA52C</b> □-CE	<b>SA53C</b> □-CE	<b>SA52RC</b> □-CE	<b>SA53RC</b> □-CE
Rated current (A)	3, 5, 10, 15, 20, 30		5, 10, 15, 20, 30, 40, 50		10, 15, 20, 30, 40, 50	
Rated interrupting capacity (kA)	415V AC 2.5/2 380V AC 2.5/2		7.5/4 7.5/4		10/5 10/5	
IEC 60947-2 (Icu/Ics)	230V AC 5/3		10/5		25/13	

Frame	60A					
Pole	2	3	2	3		
Type	<b>SA62C</b> □-CE	<b>SA63C</b> □-CE	<b>SA62RC</b> □-CE	<b>SA63RC</b> □-CE		
Rated current (A)	60		60			
Rated interrupting capacity (kA)	415V AC 7.5/4 380V AC 7.5/4		10/5 10/5			
IEC 60947-2 (Icu/Ics)	230V AC 10/5		25/13			

Frame	100A					
Pole	2	3	2	3		
Type	<b>SA102C</b> □-CE	<b>SA103C</b> □-CE	<b>SA102RC</b> □-CE	<b>SA103RC</b> □-CE		
Rated current (A)	15, 20, 30, 40, 50, 60, 75, 100		15, 20, 30, 40, 50, 60, 75, 100			
Rated interrupting capacity (kA)	415V AC 30/8 380V AC 30/8		50/13 50/13			
IEC 60947-2 (Icu/Ics)	230V AC 50/25		100/50			

Frame	225A					
Pole	2	3	2	3		
Type	<b>SA202C</b> □-CE	<b>SA203C</b> □-CE	<b>SA202RC</b> □-CE	<b>SA203RC</b> □-CE		
Rated current (A)	125, 150, 175, 200, 225		125, 150, 175, 200, 225			
Rated interrupting capacity (kA)	415V AC 30/8 380V AC 30/8		50/13 50/13			
IEC 60947-2 (Icu/Ics)	230V AC 50/25		100/50			

Frame	400A				600A	
Pole	2	3	2	3	3	
Type	<b>SA402C</b> □-CE	<b>SA403C</b> □-CE	<b>SA402RC</b> □-CE	<b>SA403RC</b> □-CE	<b>SA603RC</b> □-CE	
Rated current (A)	250, 300, 350, 400		250, 300, 350, 400		500, 600	
Rated interrupting capacity (kA)	415V AC 35/18 380V AC 35/18		50/25 50/25		50/25 50/25	
IEC 60947-2 (Icu/Ics)	230V AC 50/25		85/43		85/43	

Frame	800A	1000A	1250A	1600A
Pole	3	3	3	3
Type	<b>SA803RC</b> □-CE	<b>SA1003E</b> □-CE	<b>SA1253E</b> □-CE	<b>SA1603E</b> □-CE
Rated current (A)	700, 800	500-1000	500-1000, 630-1250	800-1600
Rated interrupting capacity (kA)	415V AC 50/25 380V AC 50/25	65/49 85/64	65/49 85/64	85/64 100/75
IEC 60947-2 (Icu/Ics)	230V AC 85/43	100/75	100/75	125/94

# Molded Case Circuit Breakers

## ■ H and L series/2, 3-pole

Frame	50A		50A	100A		
Pole	2	3	3	2	3	3
Type	<b>H52BA</b>	<b>H53BA</b>	<b>LA53B</b>	<b>H102BA</b>	<b>H103BA</b>	<b>H103R</b>
Rated current (A)	15, 20, 30, 40, 50		5, 10	15, 20, 30, 40, 50, 60, 75, 100		40, 50, 60, 75, 100
Rated interrupting capacity (kA)	440V AC	65/17	50/25	65/17	85 (*415V AC)	
	400V AC	65/17	60/30	65/17	100 (*380V AC)	
IEC 60947-2 (Icu/Ics)	230V AC	125/32	100/50	125/32	125 (*240V AC)	

Frame	225A			400A		
Pole	2	3	3	2	3	3
Type	<b>H202BA</b>	<b>H203BA</b>	<b>H203R</b>	<b>H402B</b>	<b>H403B</b>	<b>H403R</b>
Rated current (A)	125, 150, 175, 200, 225			125, 150, 175, 200, 225	250, 300, 350, 400	
Rated interrupting capacity (kA)	440V AC	65/17	85 (*415V AC)	65/33	125/63	
	400V AC	65/17	100 (*380V AC)	65/33	125/63	
IEC 60947-2 (Icu/Ics)	230V AC	125/32	125 (*240V AC)	125/63	125/63	

Frame	600A		800A	
Pole	3	3	3	3
Type	<b>H603B</b>	<b>H603R</b>	<b>H803B</b>	<b>H803R</b>
Rated current (A)	500, 600	500, 600	700, 800	700, 800
Rated interrupting capacity (kA)	440V AC	65/33	65/33	125/63
	400V AC	65/33	65/33	125/63
IEC 60947-2 (Icu/Ics)	230V AC	125/63	125/63	125/63

Note: \* Interrupting capacity are conforming to IEC 157-1

## ■ S and E series/4-pole

Frame	50A	100A	100A	225A	400A
Pole	4	4	4	4	4
Type	<b>SA54B</b>	<b>EA104B</b>	<b>SA104R</b>	<b>SA204R</b>	<b>SA404HA</b>
Rated current (A)	5, 10, 15, 20, 30, 40, 50	50, 60, 75, 100	15, 20, 30, 40, 50, 60, 75, 100	125, 150, 175, 200, 225	250, 300, 350, 400
Rated interrupting capacity (kA)	415V AC	7.5	10	45	45
	380V AC	7.5	15	50	45
IEC 157-1	240V AC	10	25	80	85

Frame	600A	800A	1000A	1250A	1600A
Pole	4	4	4	4	4
Type	<b>SA604H</b>	<b>SA804H</b>	<b>SA1004E</b> □ -CE	<b>SA1254E</b> □ -CE	<b>SA1604E</b> □ -CE
Rated current (A)	500, 600	700, 800	500-1000	500-1000, 630-1250	800-1600
Rated interrupting capacity (kA)	415V AC	45	65/49*	65/49*	85/64*
	380V AC	45	85/64*	85/64*	100/75*
IEC 157-1	240V AC	85	100/75 (* 230V AC)	100/75 (* 230V AC)	125/94 (* 230V AC)

Note: \* Interrupting capacity are conforming to IEC 60947-2 (Icu/Ics)

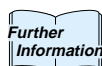

See page 06/1 of D & C catalog 19th Edition.

# Air Circuit Breakers

Provides positive protection for electric power systems



DH series

## Selection guide

Series		DH series		DA series
Frame		800, 1250, 1600, 2000, 2500, 3200, 4000A		5000, 6000A
Pole		3, 4		2, 3, 4
Installation	Fixed	Available (except 4000AF)		Not available
	Draw-out	Available		Available
Closing mechanism		Manual spring, motor spring		
Tripping mechanism		Shunt trip, undervoltage trip		
Overcurrent protection device	Characteristic	L-characteristics	Available	Available
		R-characteristics	Available	Not available
		S-characteristics	Available	Available
	Protection function	Long time delay	Available	Available
		Short time delay		
		Instantaneous		
		Pre-alarm	Available	Available
		Ground fault	Available	Available
		Earth leakage	Available	Not available
		Preverse power	Available	Not available
N-phase protection	Available	Available		
Contact temp.monitoring	Available	Not available		

## Comparison of interrupting capacity

Rated current (A)			800A	1250A	1600A	2000A	2500A	3200A	4000A	5000A	6000A
Rated interrupting capacity (kA sym.)/ Rated making current (kA peak)	Rated voltage 690V AC	DH□	50/105				65/143		75/165		
		DH□H			55/121						
		DH□P					85/187				
		DA□							85/187		
	Rated voltage 440V AC	DH□	65/143				85/187		100/220		
		DH□H			80/176						
		DH□P					100/220				
		DA□							120/264		

## Standards

IEC60947-2  
EN60947-2  
AS3947-2  
NEMA PUB No. SG3  
ANSI C37.13  
BS EN60947-2  
VDE 0660 part 101  
JIS C 8372 (JIS C8201-2)  
JEC 160

ASTA  
LR  
AB  
GL  
BV  
NK

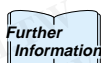

See page 08/47 of D & C catalog 19th Edition.

# Pushbuttons, Selectors, Pilot Lights

Ergonomically designed and perfectly suited for control panels

AR22, DR22 series



AR30, DR30 series



## Command Switches

AR22, DR22 series (22mm dia.)

### ■ Illuminated pushbutton switches

Operator	Flush round head	Extended round head	Extended with transparent full guard	Flush square head	Extended square head
Momentary type	AR22F0L	AR22E0L	AR22G4L	AR22F0M	AR22E0M
Alternate type	AR22F5L	AR22E5L	AR22G9L	AR22F5M	AR22E5M
Contact arrangement	1NO, 1NC, 1NO+1NC, 2NO, 2NC, 2NO+2NC, 3NO, 3NC, 4NO, 4NC, 5NO, 5NC				
Lamp voltage	5.5V AC/DC, 6V AC, 6V DC, 12V AC/DC, 15V AC/DC, 20V AC/DC, 24V AC/DC 100-110V AC, 115-127V AC, 200-220V AC, 230-254V AC, 350-380V AC, 400-440V AC, 480V AC, 500-550V AC				
Lamp	LED lamp, Incandescent lamp				
Color of lens	● Green, ● Red, ○ White, ● Yellow, ● Orange, ● Blue				

### ■ Pushbutton switches

Operator	Flush round head	Extended round head	Mushroom head	Flush square head	Flush round head with square bezel
Momentary type	AR22F0R	AR22E0R	AR22M0R	AR22F0S	AR22F0Y
Alternate type	AR22F5R	AR22E5R	AR22M5R	AR22F5S	AR22F5Y
Contact arrangement	1NO, 1NC, 1NO+1NC, 2NO, 2NC, 2NO+2NC, 3NO, 3NC, 3NO+3NC, 4NO, 4NC, 5NO, 5NC				
Color of button	● Green, ● Red, ● Black ○ White, ● Yellow, ● Orange, ● Blue				

### ■ Emergency stop pushbutton switches





Operator	Push-lock, turn-reset (40mm dia.)	Push-lock, turn-reset (29mm dia.)	Key release push-lock, turn-reset	Push-lock, pull-reset	Unibody push-lock, turn-reset
Type	AR22V0R	AR22V4R	AR22V7R	AR22Q2R	AR22VGE
Contact arrangement	1NC, 1NO+1NC, 2NC, 2NO+2NC, 3NC, 4NC				
Color of button	● Red				

The manufacturing range varies depending on the model.

## ■ Selector switches

Operator	Knob 	Lever 	Key 	Key (Long durability) 
Type Konb/key operated control	<b>AR22PR</b> <b>AR22PCR</b>	<b>AR22WR</b> <b>AR22WCR</b>	<b>AR22JR</b> <b>AR22JCR</b>	<b>AR22JAR</b> -
Contact arrangement	1NO, 1NC, 1NO+1NC, 2NO, 2NC, 2NO+2NC, 3NO, 3NC, 3NO+3NC, 4NO, 4NC, 5NO, 5NC			
Color of knob	● Black, ● Green, ● Red			

## ■ Pilot lights

Lens	Dome 	Extended round 	Flush square 	Flush square (transparent lens) 	Extended square 
Type	<b>DR22D0L</b>	<b>DR22E3L</b>	<b>DR22F3M</b>	<b>DR22F4M</b>	<b>DR22E3M</b>
Lamp voltage	5.5V AC/DC, 6V AC, 6V DC, 12V AC/DC, 15V AC/DC, 20V AC/DC, 24V AC/DC, 110V DC 100-110V AC, 115-127V AC, 200-220V AC, 230-254V AC, 350-380V AC, 400-440V AC, 480V AC, 500-550V AC				
Lamp	LED lamp, incandescent lamp				
Color of lens	● Green, ● Red, ○ White, ● Yellow, ● Orange, ● Blue				

## AR30, DR30 series (30mm dia.)

### ■ Illuminated pushbutton switches





Operator	Extended round head 	Extended with transparent full guard 	Extended with full guard (with openings) 	Extended with full guard 	Push-lock, turn-reset 
Momentary type Alternate type	<b>AR30E0L</b> <b>AR30E5L</b>	<b>AR30G4L</b> <b>AR30G9L</b>	<b>AR30G2L</b> <b>AR30G7L</b>	<b>AR30G3L</b> <b>AR30G8L</b>	- <b>AR30V5L</b>
Contact arrangement	1NO, 1NC, 1NO+1NC, 2NO, 2NC, 2NO+2NC, 3NO, 3NC, 4NO, 4NC, 5NO, 5NC				
Lamp voltage	5.5V AC/DC, 6V DC, 6V AC, 12V AC/DC, 15V AC/DC, 20V AC/DC, 24V AC/DC 100-110V AC, 115-127V AC, 200-220V AC, 230-254V AC, 350-380V AC, 400-440V AC, 480V AC, 500-550V AC				
Lamp	LED lamp, incandescent lamp				
Color of lens	● Green, ● Red, ○ White, ● Yellow, ● Orange, ● Blue				

### ■ Pushbutton switches

Operator	Flush round head 	Extended round head 	Mushroom head 	Extended with full guard 	Giant head with full guard 
Momentary type Alternate type	<b>AR30F0R</b> <b>AR30F5R</b>	<b>AR30E0R</b> <b>AR30E5R</b>	<b>AR30M0R</b> <b>AR30M5R</b>	<b>AR30G1R</b> <b>AR30G6R</b>	<b>AR30B2R</b> -
Contact arrangement	1NO, 1NC, 1NO+1NC, 2NO, 2NC, 2NO+2NC, 3NO, 3NC, 3NO+3NC, 4NO, 4NC, 4NO+4NC, 5NO, 5NC				
Color of button	● Green, ● Red, ● Black ○ White, ● Yellow, ● Orange, ● Blue				

The manufacturing range varies depending on the model.





## Emergency stop pushbutton switches

Operator	Push-lock, turn-reset (40mm dia. with white arrow) 	Push-lock, turn-reset (65mm dia.) 	Push-lock, turn-reset (40mm dia.) 	Push-lock, pull-reset 
Type	<b>AR30V0R</b>	<b>AR30V1R</b>	<b>AR30V2R</b>	<b>AR30Q2R</b>
Contact arrangement	1NC, 1NO+1NC, 2NC, 2NO+2NC, 3NC, 4NC			
Color of button	● Red			

## Selector switches

Operator	Knob 	Lever 	Key 	Key (Long durability) 
Type	<b>AR30PR</b> Knob/key operated control <b>AR30PCR</b>	<b>AR30WR</b> <b>AR30WCR</b>	<b>AR30JR</b> <b>AR30JCR</b>	<b>AR30JAR</b> -
Contact arrangement	1NO, 1NC, 1NO+1NC, 2NO, 2NC, 2NO+2NC, 3NO, 3NC, 3NO+3NC, 4NO, 4NC, 4NO+4NC, 5NO, 5NC			
Color of knob	● Black, ● Green, ● Red			

## Pilot lights

Lens	Dome 	Extended round 	Faceted 	Flush square 
Type	<b>DR30D0L</b>	<b>DR30E3L</b>	<b>DR30K0L</b>	<b>DR30F4M</b>
Lamp voltage	5.5V AC/DC, 6V AC, 6V DC, 12V AC/DC, 15V AC/DC, 20V AC/DC, 24V AC/DC, 50V DC, 110V DC, 100-110V AC, 115-127V AC, 220V DC, 200-220V AC, 230-254V AC, 350-380V AC, 400-440V AC, 480V AC, 500-550V AC			
Lamp	LED lamp, incandescent lamp			
Color of lens	● Green, ● Red, ○ White, ● Yellow, ● Orange, ● Blue			

The manufacturing range varies depending on the model.



See page 04/2 of D & C catalog 19th Edition.

# Time Delay Relays

## Direct reading time-scale and compact body



MS4S

### ■ Super timers

Description	Operation	Contact arrangement		Timer Type	Required socket		
		Timed	Instant.		Surface mounting Type	Flush mounting Type	Rail mounting Type
Super Timer Multi-range, compact body	Multi-mode	2PDT	–	<b>MS4SM</b>	TP411X 11GB + FX3 (Hold-down spring)	TP411SBA+TX4 (Adaptor) ATX2NS+TX4 (Adaptor)	TP411X
	On-delay	2PDT SPDT	– SPDT	<b>MS4SA</b> <b>MS4SC</b>	TP48X 8GB + FX3 (Hold-down spring)	TP48SB+TX4 (Adaptor) ATX1NS+TX4 (Adaptor)	TP48X
	Off-delay	2PDT SPDT	–	<b>MS4SF</b> <b>MS4SF-R</b>			
	Star-delta	2NO	1NO	<b>MS4SY</b>			
	On-delay with electrical reset	2PDT	–	<b>MS4SE</b>			
	On-off repetitive operation	2PDT	–	<b>MS4SR</b>			
	On-off	SPDT	–	<b>MS4SB</b>			
Super Timer Miniature size	On-delay	2PDT	–	<b>ST7P-2</b>	TP88 TP88R2 TP88B	–	TP88X2 TP88X1
	Off-delay	SPDT	–	<b>ST7PF</b>			
	On-delay	4PDT	–	<b>ST7P-4</b>	TP814 TP814R2 TP814B	–	TP814X2 TP814X1

### ■ Digital timers

Description	Contact arrangement		Input voltage (V)	Timer Surface mounting Type	Required socket	
	Timed	Instant.			Surface mounting Type	Flush mounting Type
Digital timer	SPDT	–	100–110V AC 200–220V AC 24V DC	<b>SD4</b> <b>SD4D</b>	TP28X-UL	TP48SB ATX1NS
	SPDT	–				

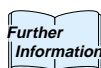

See page 03/49 of D & C catalog 19th Edition.

# Industrial Control Relays

## Reliable operation and long life



HH54

### ■ Miniature control relays HH52, 53, 54

Type	HH52□	HH53□	HH54□	HH52□U	HH54□U	HH52□W	HH54□W
Contact arrangement	2PDT	3PDT	4PDT	2PDT	4PDT	2PDT	2PDT
Contact form	Single	Single	Single	Single	Single	Bifurcated	Bifurcated
Rated thermal current	5A	5A	3A	7A	5A	5A	3A
Resistive load	120V AC	5A	5A	3A	7A	5A	3A
	240V AC	5A	5A	3A	7A	5A	3A
	30V DC	5A	5A	3A	7A	5A	3A
	120V DC	0.3A	0.3A	0.3A	0.3A	0.3A	0.3A
Inductive load	120V AC	1.5A	1.5A	1A	1.5A	1A	1A
	L/R=15ms (DC)	30V DC	2A	2A	2A	2A	2A
	Cosφ=0.3 to 0.4 (AC)	120V DC	0.2A	0.2A	0.2A	0.2A	0.2A
Contact resistance	50mΩ max.						
Coil	Rated voltage	6 to 240V AC, 6 to 110V DC (50/60Hz)					
	Power consumption	AC: 1.0/1.2VA max. (60Hz), 1.2/1.4VA max. (50Hz) DC: 0.9W					

### • Sockets

Description	Type	Used with
Soldering	TP58	HH52P
	TP511	HH53P
	TP514	HH54P
PC board	TP58B	HH52P
	TP511B	HH53P
	TP514B	HH54P
Wire wrap	TP58R2	HH52P
	TP511R2	HH53P
	TP514R2	HH54P
Rail mounting Screw terminal M3.5	TP58X2	HH52P
	TP511X2	HH53P
	TP514X2	HH54P
Rail mounting Screw terminal M3.0	TP58X1	HH52P
	TP514X1	HH54P

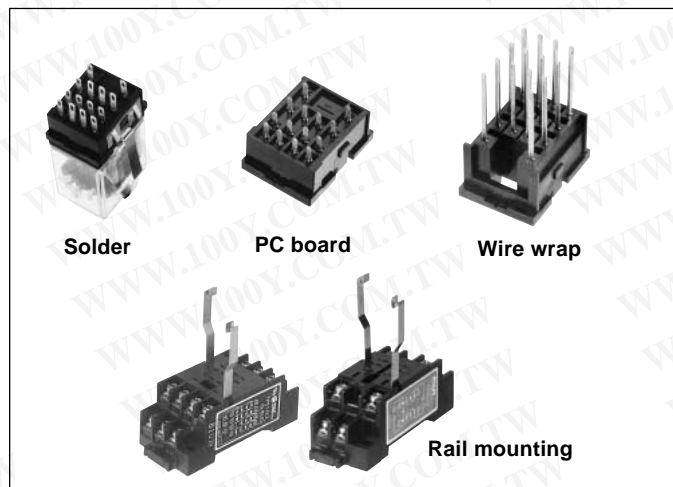

### ■ Standards

UL, CSA, TÜV

## ■ Miniature power relays HH62, 63, 64

Type	HH62□	HH63□	HH64□	HH62□W
Contact arrangement	2PDT	3PDT	4PDT	2PDT
Contact form	Single	Single	Single	Bifurcated
Rated thermal current	10A	10A	10A	7A
Resistive load	120V AC	10A	10A	5A
	240V AC	10A	10A	5A
	30V DC	8A	8A	5A
	120V DC	0.3A	0.3A	0.3A
Inductive load	120V AC	1.5A	1.5A	1.5A
	30V DC	2A	2A	2A
L/R=15ms (DC)	30V DC	2A	2A	2A
Cosφ=0.3 to 0.4 (AC)	120V DC	0.2A	0.2A	0.2A
Contact resistance	50mΩ max.			
Coil	Rated voltage	6 to 240V AC, 6 to 110V DC (50/60Hz)		
	Power consumption	AC: 2VA max. (60Hz), 2.5VA max. (50Hz) DC: 1.5W max.		

### • Sockets

Description	Type	Used with
Soldering PC board Wire wrap	TP68	HH62
	TP68B	
	TP68R	
Rail mounting screw terminal	TP68X2	HH62
	TP611X2	HH63
	TP614X2	HH64
Finger protection cover	RZ62X2	TP68X2
	RZ64X2	TP614X2

### ■ Standards

UL, CSA, TÜV

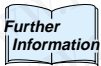

See page 03/25 of D & C catalog 19th Edition.

# Power Monitoring Unit

Performs precise energy control at low cost



## ■ F-MPC04

Type			F-MPC04	F-MPC04P			F-MPC04	
			UM01-A □ A4E	UM02-AR2	UM02-AR3	UM02-AR4	UM03-ARA3G	UM03-ARA3
			Integrated power monitoring unit	Multi-circuit power monitoring unit			Single-circuit power monitoring unit	
Measuring function	No. of phases and wires	Single-phase 2-wire	10 circuits	12 circuits	—	—	1 circuit	1 circuit
		Single-phase 3-wire	10 circuits	—	8 circuits	—		
		3-phase 3-wire	—	—	—	—		
		3-phase 4-wire	6 circuits	—	—	4 circuits		
No. of voltage circuits			2	1			1	1
Measuring item	Voltage [V]	○	○	○			○	○
		Current [A]	○	○			○	○
			Power [W]	○	○			○
		Active power [Wh]	○	○			○	○
		Reactive power [var]	○	○			○	○
		Reactive energy [varh]	○	—			○	○
		Power-factor	○	○			○	○
		Leakage current [Io]	○	—			○	—
		Basic component of leakage current [Iob]	—	—			○	—
Maintenance item	Demand	Current	○	—			○	○
		Power	○	—			○	○
		Max. current	○	—			○	○
		Max. power	○	○			○	○
	Max. voltage value	○	○			—	—	
Min. voltage value	○	○			—	—		
Harmonic current			○	—			○ (Demand only)	
Protection	Current prealarm (OCA)		○	—			○	○
	Leakage current prealarm (OCGA)		○	—			○	—
	Leakage current trip (OCG)		○	—			○	—
Communications interface			RS-485, T-link	RS-485			RS-485	RS-485
Display and setting			○	Display and setting unit UM02S			○	○
Devices to be connected	Current sensor (Current Transformer:CT)		○*	CT: 5, 50, 200, 400A				
	ZCT (separately installed)		○	—			○	—
	MCCB with ZCT		○	—			○	—

Note: \* F-MPC 04 (UM01) is connected to CT via CT-BOX.

○ Available



See page 09/119 of D & C catalog 19th Edition.

# Distribution and Control Products Sales Centers

Sales area: **China**

---

## **Fuji Electric (Shanghai) Co., Ltd.**

Suite A.B.C, 17 Fl., East Bldg.  
Shanghai New Hualian Mansion  
No. 755 Huai Hai Rd. (Middle)  
200020 Shanghai  
THE PEOPLE'S REPUBLIC OF CHINA  
Tel: +86-21-6466-2810  
Fax: +86-21-6473-3292  
URL <http://www.fesh.com.cn>

Sales area: **Hong Kong**

---

## **Fuji Electric (ASIA) Co., Ltd.**

Rm. 1001, 10 Fl., West Wing, Tsimshatsui  
Center, 66 Mody Rd., Tsimshatsui East Kowloon  
HONG KONG  
Tel: +852-2311-8282  
Fax: +852-2312-0566

Sales area: **Taiwan**

---

## **Fuji Electric FA Taiwan Co., Ltd.**

12 Fl., No. 70, Cheng Teh Rd., Sec. 1  
Taipei 103, TAIWAN ROC  
Tel: +886-2-2556-0716  
Fax: +886-2-2556-0717  
URL <http://www.fcs.fujielectric.com.tw>

Sales area: **Korea**

---

## **Fuji Electric FA KOREA Co., Ltd.**

16 Fl, Shinsong Bldg. 25-4  
Youido-dong, Youngdungpo-gu  
Seoul, 150-010, KOREA  
Tel: +82-2-780-5011  
Fax: +82-2-783-1707

Sales area: **South East Asia, Oceania**

---

## **Fuji Electric FA Singapore Private Ltd.**

171, Chin Swee Rd.  
12-01/04 San Centre  
Singapore 169877, SINGAPORE  
Tel: +65-6533-0010  
Fax: +65-6533-0021  
URL <http://www.fujielectric.com.sg>

Sales area: **Thailand**

---

## **Fuji Electric Technology Co., Ltd.**

889 Thai CC Tower, 12th Fl., Rm. 124  
South Sathorn Rd., Yannawa, Sathorn  
Bangkok 10120, THAILAND  
Tel: +66-2-210-0615  
Fax: +66-2-675-6641

Sales area: **North America**

---

## **Fuji Electric Corp. of America**

Park 80 West Plaza II, Saddle Brook  
NJ 07663, U.S.A.  
Tel: +1-201-712-0555  
Fax: +1-201-368-8258  
URL <http://www.fujielectric.com>

Sales area: **Europe**

---

## **Fuji Electric GmbH**

Goethering 58  
63067 Offenbach am Main  
F.R. GERMANY  
Tel: +49-69-6690290  
Fax: +49-69-6661020  
URL <http://www.fujielectric.de>

### **Safety Considerations**

- For safe operation, before using the product read the instruction manual or user manual that comes with the product carefully or consult the Fuji sales representative from which you purchased the product.
- Products introduced in this catalog have not been designed or manufactured for such applications in a system or equipment that will affect human bodies or lives.
- Customers, who want to use the products introduced in this catalog for special systems or devices such as for atomic-energy control, aerospace use, medical use, passenger vehicle, and traffic control, are requested to consult the Fuji sales division.
- Customers are requested to prepare safety measures when they apply the products introduced in this catalog to such systems or facilities that will affect human lives or cause severe damage to property if the products become faulty.
- For safe operation, wiring should be conducted only by qualified engineers who have sufficient technical knowledge about electrical work or wiring.

## **Fuji Electric FA Components & Systems Co., Ltd.**

5-7, Nihonbashi Odemma-cho, Chuo-ku, Tokyo, 103-0011, Japan

URL <http://www.fujielectric.co.jp/fcs/eng>



## Standard type thermal overload relays

### ■ Description

- Highly reliable thermal overload relays
- FUJI thermal overload relays are designed to provide overload protection to meet the thermal characteristics of low voltage induction motors. Adjustable thermal overload relays give motors positive overcurrent protection. The starter contacts cannot be held closing under overload conditions. However, once the bimetal element has cooled, the reset button can be depressed and the motor can be restarted in the normal manner. Ordinarily this reset is carried out manually but the starter can be changed over to 'automatic reset' by means of a screw-driver.
- FUJI thermal overload relay is subjected to stringent testing in the factory to check performance and actual values are calibrated with the markings on the adjustable dial. Consequently, they provide a positive protection.
- Relays are also provided with ambient temperature compensators, so that their performance will be maintained in spite of temperature changes. The ambient temperature is regulated for 20°C.
- The heater elements are available for either 2- or 3-pole use.

### Long time operating type

In the case of loads having large inertia moments such as blowers, winders or centrifuges the starting time is extended.

This will cause the standard-type thermal overload relay to operate during starting so isolating the motor. If necessary FUJI will supply thermal relays with saturable reactors. (Time-delay type).

### Quick operating type overload relays

The windings of submersible pump and compressor motors normally have a smaller overload capacity than those of standard motors, since they are generally cooled by the water and other medium being pumped. Q type overload relays will operate more quickly than the standard type in the face of a locked rotor current.



### ■ Features

- Isolated NO and NC contacts can be used with different potentials.
- Gold-flashed silver contact assures high contact reliability (TR-0N/3 to N14/3).
- Stable operating characteristics protect motors from burnout due to overload or locked rotor currents.
- Easy setting of current value with a calibrated dial.
- Both manual and auto reset available. A manual trip button is provided to facilitate sequence testing.
- Mechanical trip indication
- Trip-free mechanism is provided.
- Reset release button and trip indicator are optional accessories.

### ■ Warning

All FUJI thermal overload relays have been tested and calibrated at the factory. They should not be tampered with or stripped down at the job site since this would affect their accuracy. A special feature of the FUJI starter series is the ease by which the relay current ratings can be varied to match the requirements of the load. The changeover is effected by simply turning a dial to the new value required. The range of adjustment is approximately 100%–125%–150% and details are given overleaf.

### ■ Ordering information

Specify the following:

- Ordering code
  - Setting range code
- See page 01/98.

### ■ Type number nomenclature

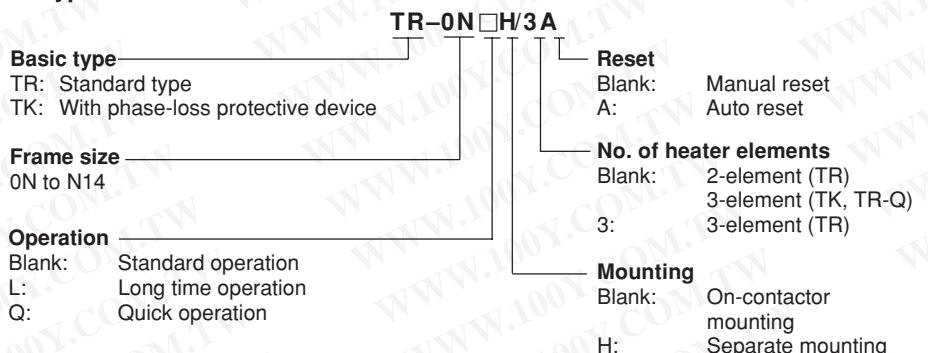

# Thermal Overload Relays

## TR series

### ■ Ordering code system

T R 2 0 B N W — T A  
 ① ② ③④ ⑤ ⑥ ⑦ — ⑧ ⑨

#### ① Product category

Description	Code
Thermal overload relay	T

#### ② Series category

Description	Code
TR-N□ series	R

#### ③④ Frame size

Frame size	Code	
	③	④
0N	1	3
5-1N	2	0
N2	3	5
N3	6	5
N5	9	3
N6	1	C
N7	1	F
N8	1	J
N10	2	C
N12	4	A
N14	6	A

#### ⑤ Index

Type	Code
TR-0N, 5-1N	Blank
TR-N2 to N14	B

#### ⑥ Version

Description	No. of element	Code
Standard	2	N
	3	D
Long time operation	2	L
	3	F
Quick operation	3	S
With phase-loss	3	E

#### ⑦ Mounting

Description	Code
On-contactor mounting	W
Separate mounting	H

#### ⑨ Reset

Description	Code
Manual reset	Blank
Auto reat	A

#### ⑧ Thermal overload relay ampere setting range

Ampere setting range (A)	Code
0.1 — 0.15	A
0.13 — 0.2	B
0.15 — 0.24	C
0.2 — 0.3	D
0.24 — 0.36	E
0.3 — 0.45	F
0.36 — 0.54	G
0.48 — 0.72	H
0.64 — 0.96	J
0.8 — 1.2	K
0.95 — 1.45	L
1.4 — 2.2	M
1.7 — 2.6	N
2.2 — 3.4	P
2.8 — 4.2	R
4 — 6	S
5 — 8	T
6 — 9	U
7 — 11	V
9 — 13	W
12 — 18	X
16 — 22	Q
18 — 26	B
24 — 36	E
28 — 40	F
32 — 42	I
34 — 50	G
45 — 65	J
48 — 68	O
53 — 80	L
65 — 95	M
85 — 105	I
85 — 125	N
110 — 160	P
125 — 185	R
160 — 240	S
200 — 300	T
240 — 360	U
300 — 450	V
400 — 600	W

#### Ordering example

① Thermal overload relay ..... T  
 ② TR-□N series ..... R  
 ③④ Frame size: 5-1N ..... 20  
 ⑤ Index ..... Blank  
 ⑥ Standard type, 3-element ..... D  
 ⑦ On-contactor mounting ..... W  
 ⑧ Ampere setting range 4-6A ..... S  
 ⑨ Auto reset ..... A

① Thermal overload relay ..... T  
 ② TR-N□ series ..... R  
 ③④ Frame size: N3 ..... 65  
 ⑤ Index ..... B  
 ⑥ With phase-loss protection ..... E  
 ⑦ On-contactor mounting ..... W  
 ⑧ Ampere setting range 24-36A ..... E  
 ⑨ Manual reset ..... Blank

TR20DW-SA

TR65BEW-E

■ Features

● Manual trip

These relays can be manually tripped for sequence inspection by pressing manual trip bar (TR-0N/3, TR-5-1N/3). A sequence inspection will be performed when the test button is pulled out. When the test button is pressed in, only the NC contact will turn OFF. The original status will be restored when the test button is then released.(TR-N2/3 to N8/3)

● Trip-free mechanism

Even if the reset button is carelessly pressed, this relay trips without trouble (Trip-free mechanism).

● Easy visual checking of operating status

Trip indicator and manual trip bar permit visual check of tripping status.

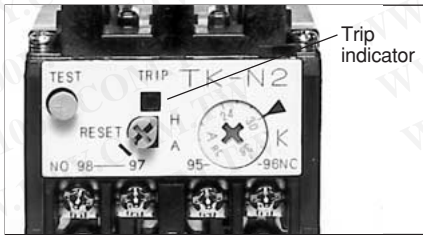

● Dial ampere setting

The setting dial uses a RC (Rated Current) marking which is set to the motor full load current.

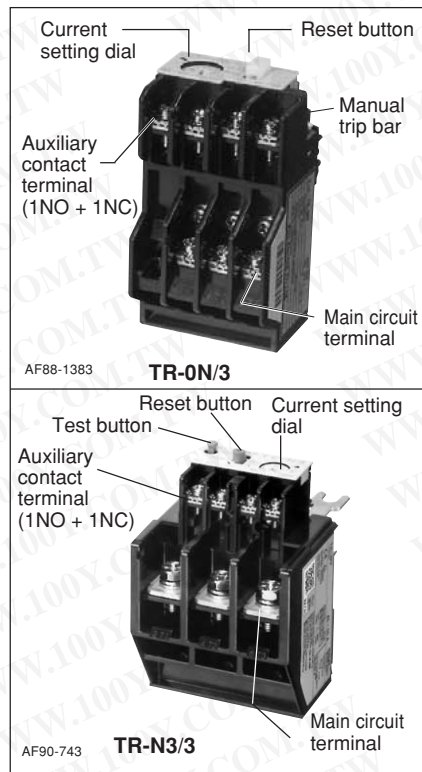

■ Versatile optional accessories  
Trip indicator



AF00-291

Reset release



AF00-585

Base unit for separate mounting



AF00-159

■ Optional accessories

Description		Type	Ordering code	Used with thermal overload relay
Reset release	Lead length 300 mm	SZ-R1 SZ-R2 SZ-R3	TZ1R1	TR-0N/3, TR-5-1N/3, TK-0N, TK-5-1N
	500 mm		TZ1R2	
	700 mm		TZ1R3	
You can reset these relays remotely on the front panels of switchboards.	Lead length 300 mm	SZ-R4 SZ-R5 SZ-R6	TZ2R4	TR-N10 to N14, TK-N10 to N14
	500 mm		TZ2R5	
	700 mm		TZ2R6	
Trip indicator	100–110V AC 50/60Hz	SZ-L100 SZ-L200	TZ1L100	TR-0N/3, TR-5-1N/3, TK-0N, TK-5-1N
	200–220V AC 50/60Hz		TZ1L200	
Easier checking of trip status	100–110V AC 50/60Hz	SZ-L100N2 SZ-L200N2	TZ2L100N2	TR-N2/3 to N8/3, TK-N2 to N8
	200–220V AC 50/60Hz		TZ2L200N2	
Dial cover For protection against the current setting being changed in error		SZ-DA	SZ1DA	TR-0N/3, TR-5-1N/3, TK-0N, TK-5-1N TR-N2/3 to N14/3, TK-N2 to N14
Base unit for separate mounting The unit can be screw-mounted and rail-mounted.		SZ-HB	TZ1HB	TR-0N/3, TK-0N
		SZ-HC	TZ1HC	TR-5-1N/3, TK-5-1N
		SZ-HD	TZ2HD	TR-N2/3, TK-N2
		SZ-HE	TZ2HE	TR-N3/3, TK-N3
		SZ-T10	SZ1T10	Base unit for separate mounting SZ-HB
Terminal cover		SZ-T11	SZ1T11	Base unit for separate mounting SZ-HC
		SZ-T14	SZ2T14	For separate mounting TR-N2H/3, TK-N2H
		SZ-T15	SZ2T15	For separate mounting TR-N3H/3, TK-N3H
		SZ-RN6T	SZ2RN6T	For separate mounting TR-N6H/3, TK-N6H
		SZ-T12	TZ1T12	TR-0N/3, TK-0N
		SZ-T13	TZ1T13	TR-5-1N/3, TK-5-1N
		SZ-T16	SZ2T16	TR-N2/3, TK-N2
		SZ-T17	SZ2T17	TR-N3/3, TK-N2

# Thermal Overload Relays

## TR series

### Standard type

#### ■ Selection guide/Standard type

On-contactor mounting	3-element 2-element	TR-0N/3 (TR13DW) TR-0N (TR13NW)	TR-5-1N/3 (TR20DW) TR-5-1N (TR20NW)	TR-N2/3 (TR35BDW) TR-N2 (TR35BNW)	TR-N3/3 (TR65BDW) TR-N3 (TR65BNW)				
Separate mounting	3-element 2-element	TR-0NH/3 (TR13DH) TR-0NH (TR13NH)	TR-5-1NH/3 (TR20DH) TR-5-1NH (TR20NH)	TR-N2H/3 (TR35BDH) TR-N2H (TR35BNH)	TR-N3H/3 (TR65BDH) TR-N3H (TR65BNH)				
Contactor to be combined		SC-03	SC-0 SC-05	SC-4-0	SC-4-1 SC-5-1	SC-N1	SC-N2	SC-N2S	SC-N3
Ampere setting range (A)	Code	A	0.1 – 0.15	0.1 – 0.15	0.1 – 0.15	0.1 – 0.15			
		B	0.13 – 0.2	0.13 – 0.2	0.13 – 0.2	0.13 – 0.2			
		C	0.15 – 0.24	0.15 – 0.24	0.15 – 0.24	0.15 – 0.24			
		D	0.2 – 0.3	0.2 – 0.3	0.2 – 0.3	0.2 – 0.3			
		E	0.24 – 0.36	0.24 – 0.36	0.24 – 0.36	0.24 – 0.36			
		F	0.3 – 0.45	0.3 – 0.45	0.3 – 0.45	0.3 – 0.45			
		G	0.36 – 0.54	0.36 – 0.54	0.36 – 0.54	0.36 – 0.54			
		H	0.48 – 0.72	0.48 – 0.72	0.48 – 0.72	0.48 – 0.72			
		J	0.64 – 0.96	0.64 – 0.96	0.64 – 0.96	0.64 – 0.96			
		K	0.8 – 1.2	0.8 – 1.2	0.8 – 1.2	0.8 – 1.2			
		L	0.95 – 1.45	0.95 – 1.45	0.95 – 1.45	0.95 – 1.45			
		M	1.4 – 2.2	1.4 – 2.2	1.4 – 2.2	1.4 – 2.2			
		N	1.7 – 2.6	1.7 – 2.6	1.7 – 2.6	1.7 – 2.6			
		P	2.2 – 3.4	2.2 – 3.4	2.2 – 3.4	2.2 – 3.4			
		R	2.8 – 4.2	2.8 – 4.2	2.8 – 4.2	2.8 – 4.2			
		S	4 – 6	4 – 6	4 – 6	4 – 6	4 – 6	4 – 6	
		T	5 – 8	5 – 8	5 – 8	5 – 8	5 – 8	5 – 8	
		U	6 – 9	6 – 9	6 – 9	6 – 9	6 – 9	6 – 9	
		V	7 – 11	7 – 11	7 – 11	7 – 11	7 – 11	7 – 11	7 – 11
		W		9 – 13	9 – 13	9 – 13	9 – 13	9 – 13	9 – 13
		X			12 – 18	12 – 18	12 – 18	12 – 18	12 – 18
		Q				16 – 22			
		B					18 – 26	18 – 26	18 – 26
		E					24 – 36	24 – 36	24 – 36
		F						28 – 40	28 – 40
		I						32 – 42	
		G							34 – 50
		J							45 – 65
		O							48 – 68
		L							53 – 80*
		M							65 – 95*
		I							85 – 105*

On-contactor mounting	3-element 2-element	TR-N5/3 (TR80BDW) TR-N5 (TR80BNW)	TR-N6/3 (TR1CBDW) TR-N6 (TR1CBNW)	TR-N7/3 (TR1FBDW) TR-N7 (TR1FBNW)	TR-N8/3 (TR1JBDW) TR-N8 (TR1JBNW)	TR-N10/3 (TR2CBDW) TR-N10 (TR2CBNW)	TR-N12/3 (TR4ABDW) TR-N12 (TR4ABNW)	TR-N14/3 (TR8ABDW) TR-N14 (TR8ABNW)		
Separate mounting	3-element 2-element	– –	TR-N6H/3 (TR1CBDH) TR-N6H (TR1CBNH)	– –	– –	TR-N10H/3 (TR2CBDH) TR-N10H (TR2CBNH)	TR-N12H/3 (TR4ABDH) TR-N12H (TR4ABNH)	TR-N14H/3 (TR8ABDH) TR-N14H (TR8ABNH)		
Contactor to be combined		SC-N4	SC-N5	SC-N6	SC-N7	SC-N8	SC-N10	SC-N11	SC-N12	SC-N14
Ampere setting range (A)	Code	B	18 – 26	18 – 26						
		E	24 – 36	24 – 36						
		F	28 – 40	28 – 40						
		G	34 – 50	34 – 50						
		J	45 – 65	45 – 65	45 – 65	45 – 65				
		L	53 – 80	53 – 80	53 – 80	53 – 80				
		M		65 – 95	65 – 95	65 – 95	65 – 95			
		I		85 – 105						
		N			85 – 125	85 – 125	85 – 125			
		P			110 – 160*	110 – 160	110 – 160	110 – 160	110 – 160	
		R					125 – 185	125 – 185	125 – 185	
		S					160 – 240	160 – 240	160 – 240	
		T						200 – 300	200 – 300	
		U							240 – 360	240 – 360
		V							300 – 450	300 – 450
		W								400 – 600

- Notes:
- TR-N10/3 to N14/3 types are provided with CTs.
  - Max. setting ranges of these starters are as shown in the table on the right.
  - When ordering the thermal overload relays for starter use, select the applicable setting range.
- ( ) : Basic ordering code (When ordering phase-loss protective type, enter the version code E instead of D)
- \* : Separate mounting only

Motor starter	Maximum applicable heater range (A)	
	200–240V	380–440V
SW-03/3H	7–11	6–9
SW-4-0/3H	12–18	12–18
SW-N1/3H	24–36	24–36
SW-N2S/3H	34–50	34–50
SW-N4/3H	53–80	53–80
SW-N6/3H	85–125	85–125

■ Selection guide/Long time operating type

On-contactor mounting	3-element	–	–	–	TR-N2L/3 (TR35BFW)	TR-N3L/3 (TR65BFW)			
	2-element	–	–	–	TR-N2L (TR35BLW)	TR-N3L (TR65BLW)			
Separate mounting	3-element	TR-0NLH/3 (TR13FH)	TR-5-1NLH/3 (TR20FH)	TR-N2LH/3 (TR35BFH)	TR-N3LH/3 (TR65BFH)				
	2-element	TR-0NLH (TR13LH)	TR-5-1NLH (TR20LH)	TR-N2LH (TR35BLH)	TR-N3LH (TR65BLH)				
Contactor to be combined		SC-03	SC-0 SC-05	SC-4-0	SC-4-1 SC-5-1	SC-N1	SC-N2	SC-N2S	SC-N3
Ampere setting range (A)	Code	L	0.95 – 1.45	0.95 – 1.45	0.95 – 1.45	0.95 – 1.45			
	M	1.4 – 2.2	1.4 – 2.2	1.4 – 2.2	1.4 – 2.2				
	N	1.7 – 2.6	1.7 – 2.6	1.7 – 2.6	1.7 – 2.6				
	P	2.2 – 3.4	2.2 – 3.4	2.2 – 3.4	2.2 – 3.4				
	R	2.8 – 4.2	2.8 – 4.2	2.8 – 4.2	2.8 – 4.2				
	S	4 – 6	4 – 6	4 – 6	4 – 6	4 – 6	4 – 6		
	T	5 – 8	5 – 8	5 – 8	5 – 8	5 – 8	5 – 8		
	U	6 – 9	6 – 9	6 – 9	6 – 9	6 – 9	6 – 9		
	V	7 – 11	7 – 11	7 – 11	7 – 11	7 – 11	7 – 11	7 – 11	7 – 11
	W		9 – 13	9 – 13	9 – 13	9 – 13	9 – 13	9 – 13	9 – 13
	X			12 – 18	12 – 18	12 – 18	12 – 18	12 – 18	12 – 18
	B					18 – 26	18 – 26	18 – 26	18 – 26
	E						24 – 36	24 – 36	24 – 36
F							28 – 40	28 – 40	
G							34 – 50	34 – 50	
J								45 – 65	
L								53 – 80*	
M								65 – 95*	

On-contactor mounting	3-element	TR-N5L/3 (TR80BFW)	TR-N6L/3 (TR1CBFW)	TR-N7L/3 (TR1FBFW)	TR-N10L/3 (TR2CBFW)	TR-N12L/3 (TR4ABFW)	TR-N14L/3 (TR8ABFW)			
	2-element	TR-N5L (TR80BLW)	TR-N6L (TR1CBLW)	TR-N7L (TR1FBLW)	TR-N10L (TR2CBLW)	TR-N12L (TR4ABLW)	TR-N14L (TR8ABLW)			
Separate mounting	3-element	–	TR-N6LH/3 (TR1CBFH)	–	TR-N10LH/3 (TR2CBFH)	TR-N12LH/3 (TR4ABFH)	TR-N14LH/3 (TR8ABFH)			
	2-element	–	TR-N6LH (TR1CBLH)	–	TR-N10LH (TR2CBLH)	TR-N12LH (TR4ABLH)	TR-N14LH (TR8ABLH)			
Contactor to be combined		SC-N4	SC-N5	SC-N6	SC-N7	SC-N8	SC-N10	SC-N11	SC-N12	SC-N14
Ampere setting range (A)	Code	B	18 – 26	18 – 26						
	E	24 – 36	24 – 36							
	F	28 – 40	28 – 40							
	G	34 – 50	34 – 50							
	J	45 – 65	45 – 65	45 – 65	45 – 65					
	L	53 – 80	53 – 80	53 – 80	53 – 80					
	M		65 – 95	65 – 95	65 – 95					
	N			85 – 125	85 – 125	85 – 125	85 – 125			
	P			110 – 160*	110 – 160	110 – 160	110 – 160	110 – 160	110 – 160	
	R					125 – 185	125 – 185	125 – 185	125 – 185	
	S						160 – 240	160 – 240	160 – 240	
	T							200 – 300	200 – 300	
	U								240 – 360	240 – 360
V								300 – 450	300 – 450	
W									400 – 600	

Notes: Maximum setting ranges of these starters are as shown in the table below. ( ): Basic ordering code  
Select the applicable setting range when ordering the thermal overload relays for starter use. \*: Separate mounting only

Motor starter	Maximum applicable heater range (A)	
	200–240V	380–440V
SW-03/2L, 3L	7–11	6–9
SW-N2S/2L, 3L	34–50	34–50
SW-N4/2L, 3L	53–80	53–80
SW-N6/2L, 3L	85–125	85–125

# Thermal Overload Relays

## TR series

### Quick operating type

#### ■ Selection guide/Quick operating type

On-contactor mounting	3-element	TR-0NQ (TR13SW)		TR-5-1NQ (TR20SW)		TR-N2Q (TR35BSW)	
Separate mounting	3-element	-		-		-	
Contactor to be combined		SC-03	SC-0 SC-05	SC-4-0	SC-4-1 SC-5-1	SC-N1	SC-N2
Rated operational current (A)	200-240V 380-440V	11 9	13 12	18 16	22 22	27 30	39 37
Ampere setting range (A)	<b>Code</b>	<b>M</b>	<b>N</b>	<b>P</b>	<b>R</b>	<b>S</b>	<b>T</b>
		1.4 - 2.2	1.7 - 2.6	2.2 - 3.4	2.8 - 4.2	4 - 6	5 - 8
		1.4 - 2.2	1.7 - 2.6	2.2 - 3.4	2.8 - 4.2	4 - 6	5 - 8
		1.4 - 2.2	1.7 - 2.6	2.2 - 3.4	2.8 - 4.2	4 - 6	5 - 8
		1.4 - 2.2	1.7 - 2.6	2.2 - 3.4	2.8 - 4.2	4 - 6	5 - 8
		4 - 6	4 - 6	4 - 6	4 - 6	4 - 6	4 - 6
		5 - 8	5 - 8	5 - 8	5 - 8	5 - 8	5 - 8
		6 - 9	6 - 9	6 - 9	6 - 9	6 - 9	6 - 9
		7 - 11 *1	7 - 11 *1	7 - 11 *1	7 - 11 *1	7 - 11 *1	7 - 11 *1
		9 - 13 *1	9 - 13 *1	9 - 13 *1	9 - 13 *1	9 - 13 *1	9 - 13 *1
				12 - 18 *1	12 - 18 *1	12 - 18	12 - 18
						18 - 26	18 - 26
							24 - 36

On-contactor mounting	3-element	TR-N3Q (TR65BSW)		TR-N5Q (TR80SW)	
Separate mounting	3-element	TR-N3Q (TR65BSW)		-	
Contactor to be combined		SC-N2S	SC-N3	SC-N4	SC-N5
Rated operational current (A)	200-240V 380-440V	52 48	65 65	80 80	105 105
Ampere setting range (A)	<b>Code</b>	<b>B</b>	<b>E</b>	<b>F</b>	<b>G</b>
		18-26	24-36	28-40	34-50
		18-26	24-36	28-40	34-50
		18-26	24-36	28-40	34-50
		18-26	24-36	28-40	34-50
		24-36	24-36	24-36	24-36
		28-40	28-40	28-40	28-40
		34-50	34-50	34-50	34-50
		45-65	45-65	45-65	45-65
		53-80*2	53-80	53-80	53-80
		65-95*2	65-95*2	65-95	65-95

Notes: \*1 Thermal overload relay with phase-loss protection is available with \*1 marked setting ranges of TR-0NQ, TR-5-1NQ and all setting ranges of TR-N2Q to N5Q.

Type numbers are TK-0NQ, TK-5-1NQ, TK-N2Q to N5Q. The setting ranges of these TK-□Q type relays are as same as those of the above setting ranges.

\*2 Separate mounting only.

( ) Basic ordering code

#### ■ Ratings of auxiliary contact

Type	Rated thermal current (A)	Rated voltage (V)	Rated AC operational current (A)	Rated DC operational current (A)
TR-0N, 5-1N TR-0N/3, 5-1N/3 TK-0N, 5-1N TR-0NQ, 5-1NQ	3	24 100-120 200-240 380-440 500-600	3 (0.3)* 2.5 (0.3)* 2 (0.3)* 1 (0.3)* 0.6 (0.3)*	1.1 (0.3)* 0.28 0.14 - -
TR-N2 to N8 TR-N2/3 to N8/3 TK-N2 to N8 TR-N2Q to N5Q	5	24 100-120 200-240 380-440 500-600	3 (0.5)* 2.5 (0.5)* 2 (0.5)* 1 (0.5)* 0.6 (0.5)*	1.1 (0.3)* 0.28 0.14 - -
TR-N10 to N14 TR-N10/3 to N14/3 TK-N10 to N14	5	24 100-120 200-240 380-440 500-600	3 (0.3)* 2.5 (0.3)* 2 (0.3)* 1 (0.3)* 0.6 (0.3)*	1.1 (0.3)* 0.28 0.14 - -

Notes: Conforming to Class AC-15, DC-13, IEC, JIS, and JEM.

( ) \* NO contact of auto reset type.





■ Dimensions, mm

Base unit for separate mounting

SZ-HB

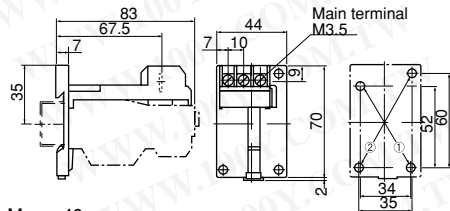

Mass: 40g

SZ-HC

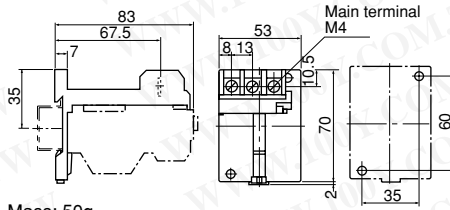

Mass: 50g

SZ-HD

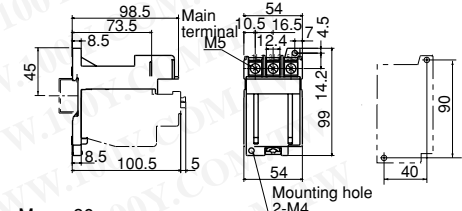

Mass: 90g

SZ-HE

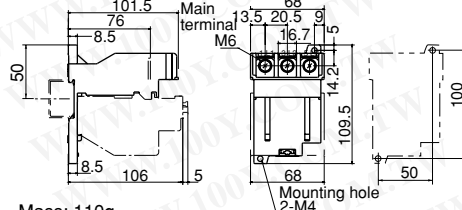

Mass: 110g

■ Mass/Standard and quick operating types

On-contactor mounting		Separate mounting		On-contactor mounting		Separate mounting	
Type	Mass	Type	Mass	Type	Mass	Type	Mass
TR-0N	0.09kg	TR-0NH	0.13kg	TR-N7	0.61kg		
TR-0N/3	0.10kg	TR-0NH/3	0.14kg	TR-N7/3	0.61kg		
TR-0NQ	0.10kg						
TR-5-1N	0.11kg	TR-5-1NH	0.16kg	TR-N8	1.2kg		
TR-5-1N/3	0.12kg	TR-5-1NH/3	0.17kg	TR-N8/3	1.2kg		
TR-5-1NQ	0.12kg						
TR-N2, N2/3	0.2kg	TR-N2H	0.29kg	TR-N10	1.85kg	TR-10NH	1.5kg
TR-N2Q	0.2kg	TR-N2H/3	0.29kg	TR-N10/3	1.85kg	TR-10NH/3	1.5kg
TR-N3, N3/3	0.27kg	TR-N3H, N3H/3	0.38kg	TR-N12, N12/3	2.3kg	TR-12NH, 12NH/3	2.25kg
TR-N3Q	0.27kg						
TR-N5, N5/3	0.27kg			TR-N14, N14/3	3.5kg	TR-14NH, 14NH/3	4kg
TR-N5Q	0.27kg						
TR-N6, N6/3	0.61kg	TR-N6H, N6H/3	0.67kg				

■ Dimensions, mm

Long time operating type

TR-0NLH, 0NLH/3

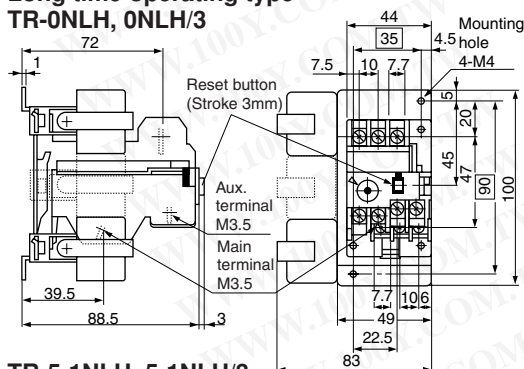

TR-5-1NLH, 5-1NLH/3

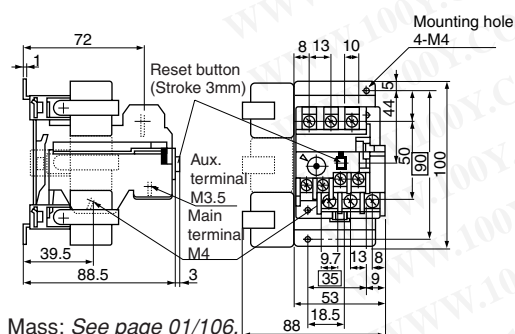

Mass: See page 01/106.

TR-N2L, N2L/3

On-contactor mounting

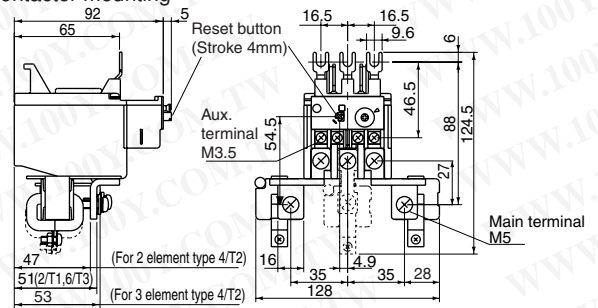

TR-N2LH, N2LH/3

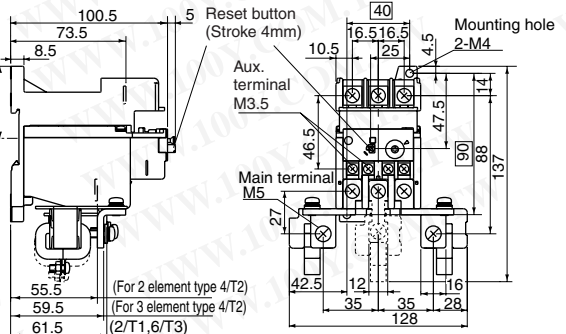

# Thermal Overload Relays

## TR series

### ■ Dimensions, mm

#### Long time operating type

#### TR-N3L, N3L/3

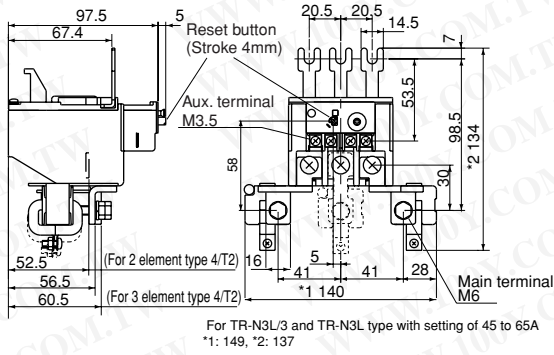

#### TR-N6L, N6L/3

#### On-contactor mounting

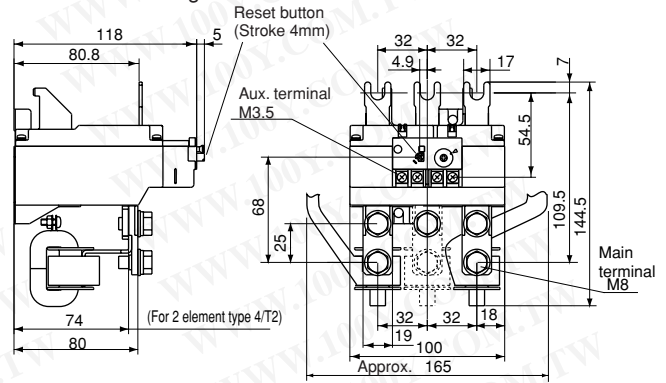

#### TR-N3LH, N3LH/3

#### On-contactor mounting

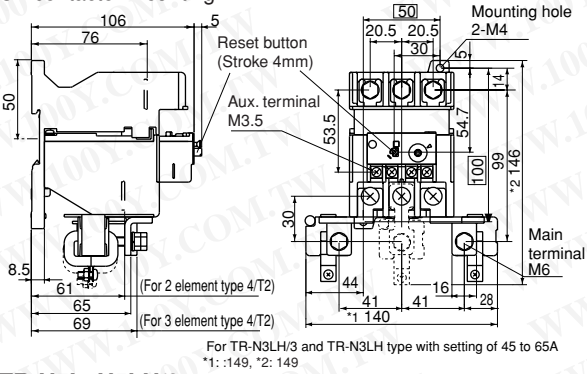

#### TR-N6LH, N6LH/3

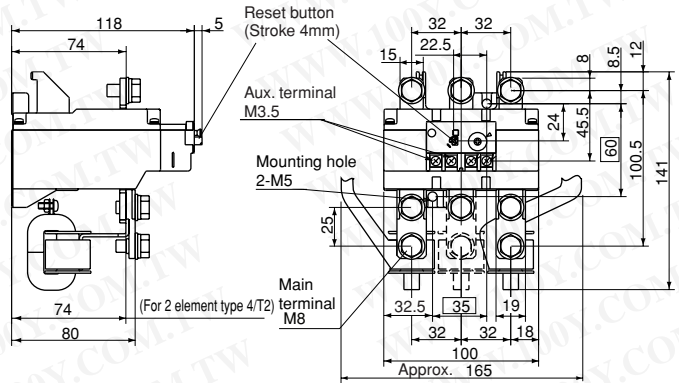

#### TR-N5L, N5LH/3

#### On-contactor mounting

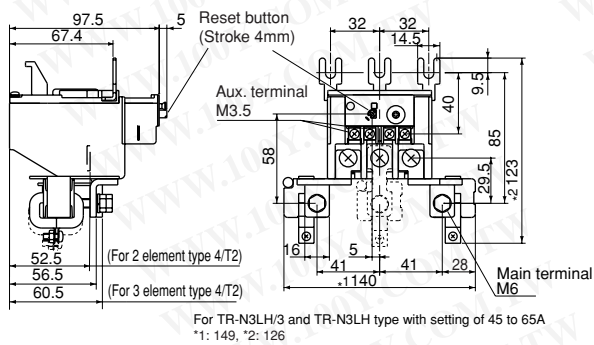

#### TR-N7L, N7L/3

#### On-contactor mounting

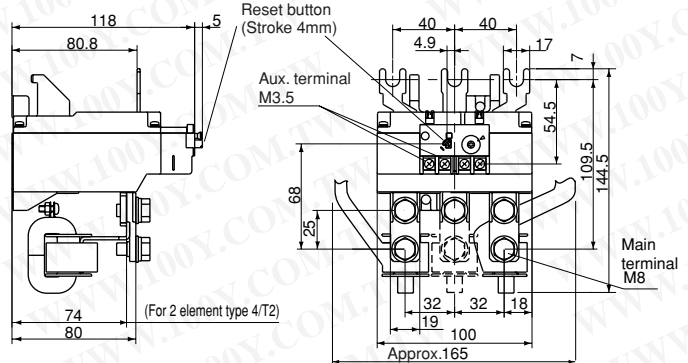

Note: TR-N10L, N10LH, N12NL, N12LH, N14L and N14LH types have the same dimensions as standard types. See pages 01/105.

### ■ Mass/Long time operating type

On-contactor mounting Type	Mass	Separate mounting Type	Mass	On-contactor mounting Type	Mass	Separate mounting Type	Mass
-		TR-0NLH	0.4kg	TR-N6L	1.54kg	TR-N6LH	1.6kg
-		TR-0NLH/3	0.5kg	TR-N6L/3	1.85kg	TR-N6LH/3	1.91kg
-		TR-5-1NLH	0.42kg	TR-N7L	1.54kg	-	
-		TR-5-1NLH/3	0.52kg	TR-N7L/3	1.85kg	-	
TR-N2L	0.56kg	TR-N2LH	0.65kg	TR-N10L	1.85kg	TR-N10LH	1.5kg
TR-N2L/3	0.68kg	TR-N2LH/3	0.77kg	TR-N10L/3	1.85kg	TR-N10LH/3	1.5kg
TR-N3L	0.63kg	TR-N3LH	0.74kg	TR-N12L	2.3kg	TR-N12LH	2.25kg
TR-N3L/3	0.77kg	TR-N3LH/3	0.88kg	TR-N12L/3	2.3kg	TR-N12LH/3	2.25kg
TR-N5L	0.63kg	-		TR-N14L	3.5kg	TR-N14LH	4kg
TR-N5L/3	0.77kg	-		TR-N14L/3	3.5kg	TR-N14LH/3	4kg

■ Dimensions, mm  
Optional accessories  
Trip indicator

SZ-L100  
SZ-L200

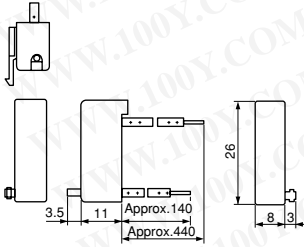

SZ-L100N2  
SZ-L200N2

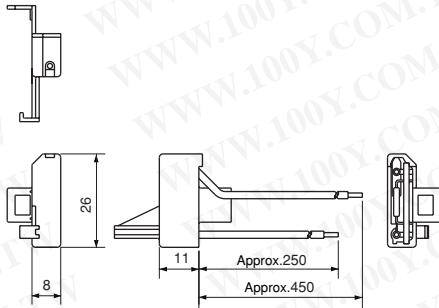

Reset release button

SZ-R1  
SZ-R2  
SZ-R3

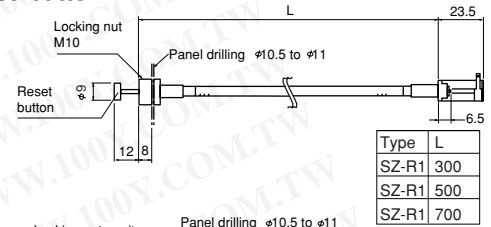

SZ-R4  
SZ-R5  
SZ-R6

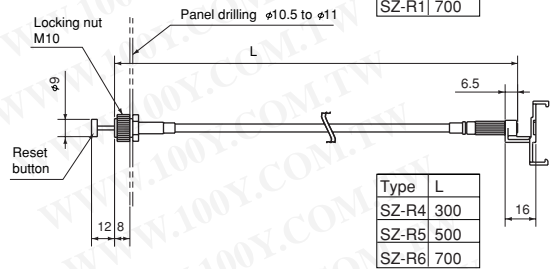

Dial cover  
SZ-DA

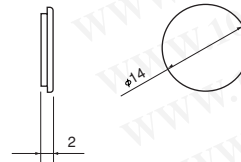

■ Characteristic curves These curves show cold starting characteristics.

● Standard type

TR-0N, 5-1N,  
TR-0N/3, 5-1N/3,  
TR-0NH, 5-1NH,  
TR-0NH/3, 5-1NH/3

TR-N2 to N8  
TR-N2/3 to N8/3  
TR-N2H, N3H, N6H  
TR-N2H/3, N3H/3, N6H/3

TR-N10 to N14,  
TR-N10/3 to N14/3,  
TR-N10H to N14H  
TR-N10H/3 to N14H/3

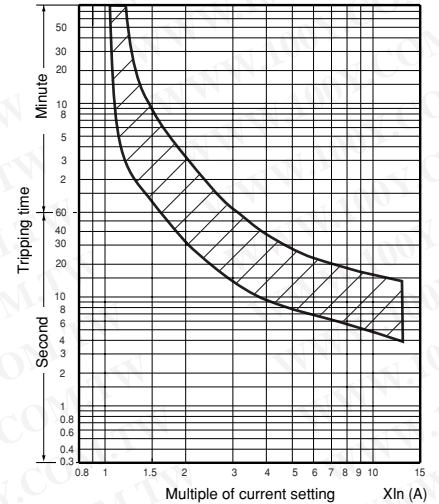
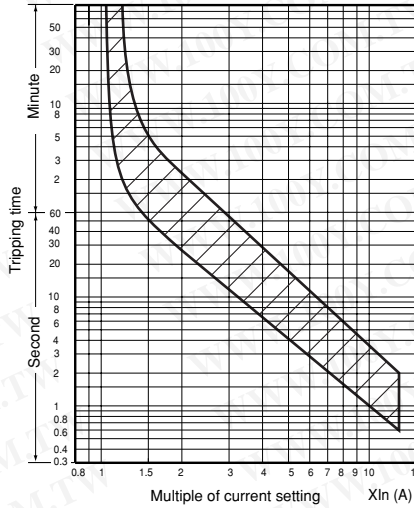
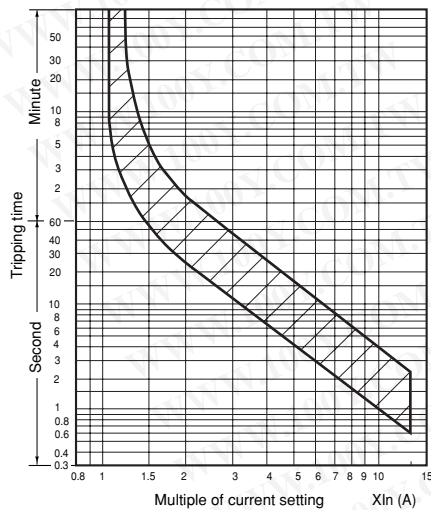

■ Wiring diagrams

● Standard type

TR-0N to N8  
TR-0N/3 to N8/3  
TR-0NH, 5-1NH, N2H, N3H, N6H  
TR-0NH/3, 5-1NH/3, N2H/3, N3H/3, N6H/3

TR-N10 to N14  
TR-N10/3 to N14/3  
TR-N10H to N14H  
TR-N10H/3 to N14H/3

2-element

3-element

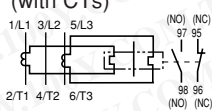
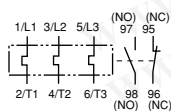
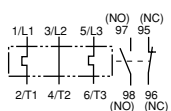

3-element  
(with CTs)

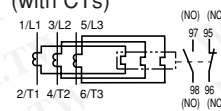

# Thermal Overload Relays TR series

勝特力材料 886-3-5753170  
 勝特力电子(上海) 86-21-54151736  
 勝特力电子(深圳) 86-755-83298787  
[Http://www.100y.com.tw](http://www.100y.com.tw)

■ **Characteristic curves** These curves show cold starting characteristics  
 ● **Long time operating type** (When setting at the center dial current)

TR-0NL, 5-1NL  
 TR-0NL/3, 5-1NL/3  
 TR-0NLH, 5-1NLH  
 TR-0NLH/3, 5-1NLH/3

TR-N2L to N7L  
 TR-N2L/3 to N7L/3  
 TR-N2LH, N3LH, N6LH  
 TR-N2LH/3, N3LH/3, N6LH/3

TR-N10L to N14L  
 TR-N10L/3 to N14L/3  
 TR-N10LH to N14LH  
 TR-N10LH/3 to N14LH/3

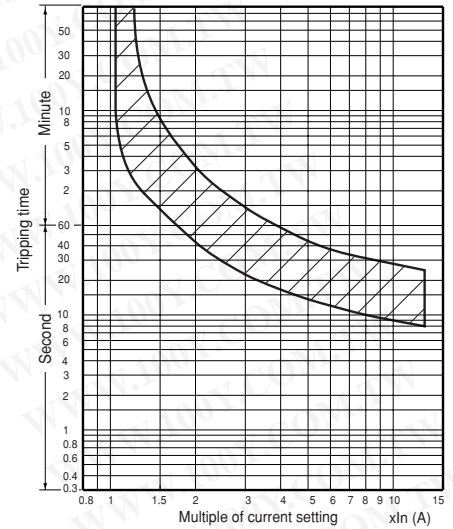
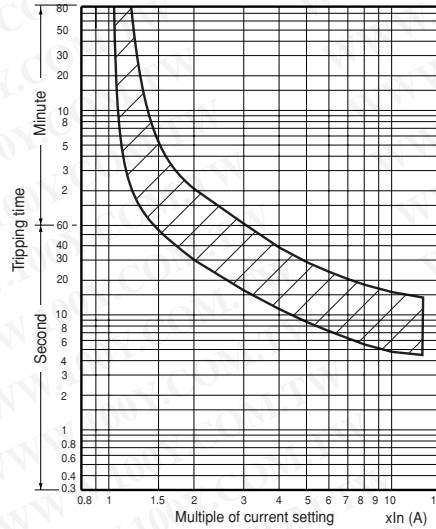
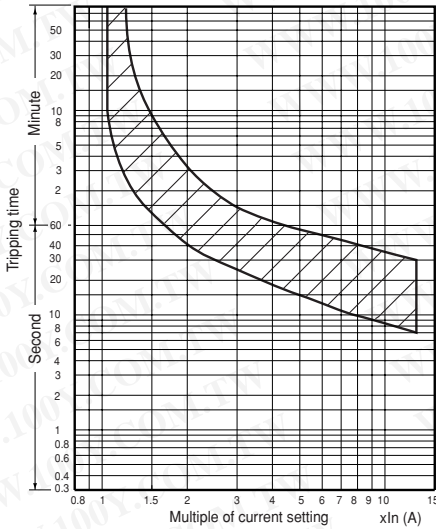

● **Quick operating type**  
 TR-0NQ, 5-1NQ

TR-N2Q, N3Q, N5Q

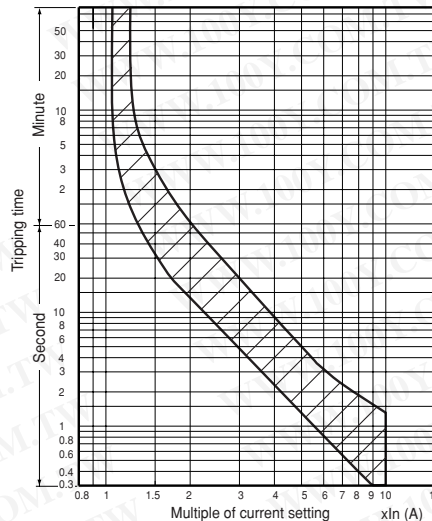
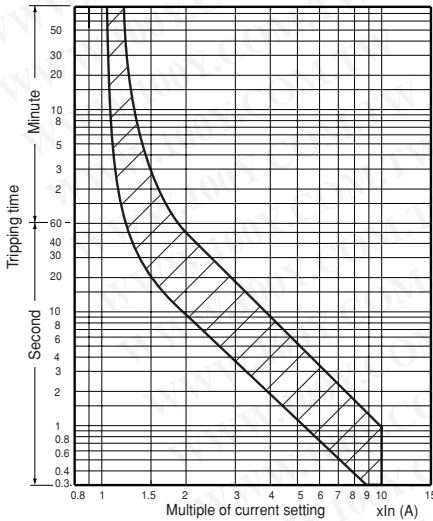

## ■ Wiring diagrams

● **Long time operating type**

TR-0NL to N7L  
 TR-0NL/3 to N7L/3  
 TR-0NLH, 5-1NLH, N2LH, N3LH, N6LH  
 TR-0NLH/3, 5-1NLH/3, N2LH/3, N3LH/3, N6LH/3

2-element

3-element

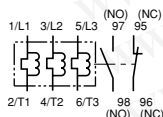
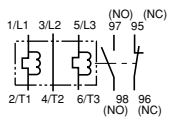

TR-N10L to N14L  
 TR-N10L/3 to N14L/3  
 TR-N10LH to N14LH  
 TR-N10LH/3 to N14LH/3

2-element  
(with CTs)

3-element  
(with CTs)

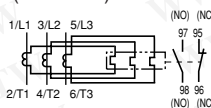
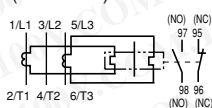

● **Quick operating type**

TR-0NQ, 5-1NQ  
 TR-N2Q, N3Q, N5Q

3-element

