

勝特力材料 886-3-5753170
 勝特力电子(上海) 86-21-54151736
 勝特力电子(深圳) 86-755-83298787
 Http://www.100y.com.tw

CP31, CP31D, CP32D circuit protectors

250V AC 0.3A to 30A
 50V DC 0.3A to 30A

■ **Description**

The CP31 and CP32 have a similar functions to a molded case circuit breaker and they can be used for normal switching ON and OFF operations while breaking both overload and short-circuit currents. They are available in two time-current versions—an instantaneous and a time-delay version. A suitable type should be selected to match the thermal and permissible current requirements. These are recommended for sequential control circuits, motor control circuits, solenoid-operated valves, heaters and solid-state applications.

■ **Features**

- Excellent arc interruption
 Since the arc extinguisher uses a loop blow-out system the arc is rapidly extinguished.
- Highly visible handle indication ON shows red and OFF or TRIP blue.
- When positioned at ON the operating handle is completely housed inside the molded case and does not protrude.
 This helps to prevent erroneous operation.
- Trip-free mechanism
- Also available with auxiliary switch SPDT.
- Two time-current versions— instantaneous operation and a time delay type. Select the model best suited to your protection needs.
- CP31D and CP32D types are of front and rail dual mounting.

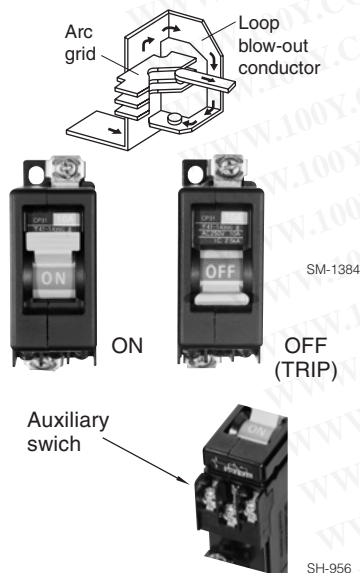

■ **Time-delay tripping type**

Rated current (A)	CP31 (1-pole) Front mounting Type	Rail mounting Type	CP31D (1-pole) Type	CP32D (2-pole) Type
0.3	CP31/0.3	CP31/0.3X	CP31D/0.3	CP32D/0.3
0.5	CP31/0.5	CP31/0.5X	CP31D/0.5	CP32D/0.5
1	CP31/1	CP31/1X	CP31D/1	CP32D/1
2	CP31/2	CP31/2X	CP31D/2	CP32D/2
3	CP31/3	CP31/3X	CP31D/3	CP32D/3
5	CP31/5	CP31/5X	CP31D/5	CP32D/5
7	CP31/7	CP31/7X	CP31D/7	CP32D/7
10	CP31/10	CP31/10X	CP31D/10	CP32D/10
15	CP31/15	CP31/15X	CP31D/15	CP32D/15
20	CP31/20	CP31/20X	CP31D/20	CP32D/20
25	CP31/25	CP31/25X	CP31D/25	CP32D/25
30	CP31/30	CP31/30X	CP31D/30	CP32D/30

■ **Typical applications**

These CP31 and CP32 protectors are used for normal on-off switching of the power supply while also providing overload protection of the load circuits.

Time-delay tripping type

- Control circuits
- Solenoid valves and motor circuits
- Heater circuits

Instantaneous tripping type

- Semiconductor circuits
- SCR (Silicon controlled rectifier) and triac circuits
- Computer peripheral equipment

■ **Type number nomenclature**

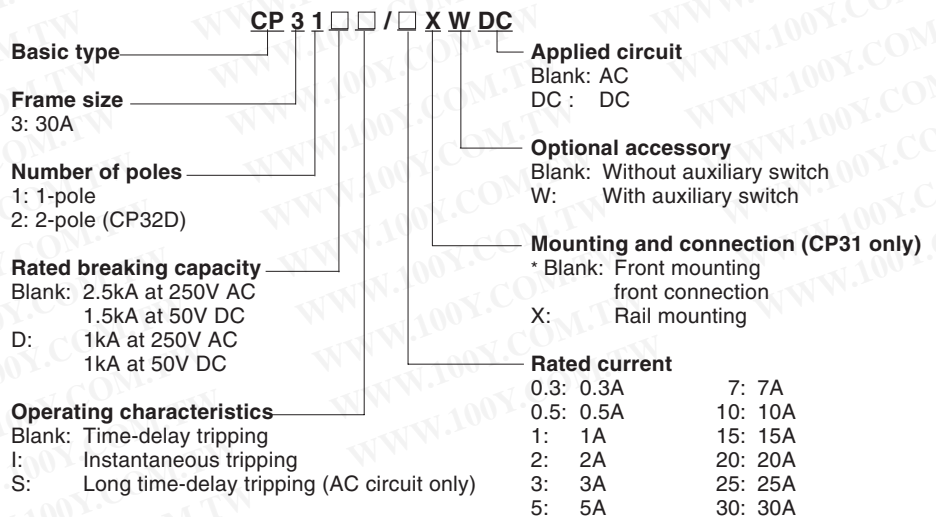

* One and the same CP31D and CP32D can be used for both front mounting and rail mounting.

Circuit Protectors CP31, CP31D, CP32D

勝特力材料 886-3-5753170
胜特力电子(上海) 86-21-54151736
胜特力电子(深圳) 86-755-83298787
[Http://www.100y.com.tw](http://www.100y.com.tw)

■ Operation

The operation of the magnetic overload release of the CP31, CP31D and CP32D circuit protectors are as shown in the sectional diagram Fig. 1. The magnetic tripping element of the circuit protector is simple—a solenoid coil wound around a hermetically-sealed non-magnetic cylinder containing a spring-loaded movable iron core and a silicon fluid.

When currents less than the rated value flow no movement occurs in either the armature or iron core.

However, when a sustained overcurrent occurs the magnetic field is increased. This causes the iron core to move along the cylinder. Once the core reaches the opposite end of the cylinder the armature is attracted which causes the protector to trip as shown in Fig. 2 and 3.

When a short circuit occurs the magnetic flux produced in the coil alone is strong enough to attract the armature regardless of core position. This causes circuit to be interrupted instantaneously. (Fig. 4)

Fig. 1 Normal load

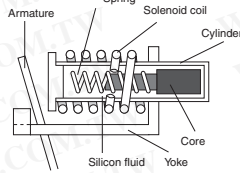

Fig. 2 Overcurrent

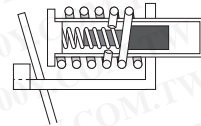

Fig. 3 Overcurrent trip

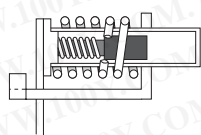
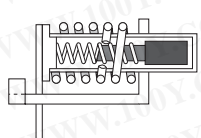

Fig. 4 Short-circuit current trip



■ Adaptor for flush mounting/CP-E1

These circuit protectors can be modified for flush mounting use by a snap-fitting adaptor CP-E1.



Flush mounting Front mounting

■ Snap-on mounting terminal covers

For main terminal: CP-T1
For auxiliary terminal: CP-T2

■ Specifications

Description	CP31	CP31D	CP32D
Pole	1-pole	1-pole	2-pole
Frame size	30 Amps.	30 Amps.	
Rated insulation voltage (Ui)	250V AC, 50V DC	250V AC, 50V DC	
Rated operational voltage (Ue)	250V AC, 50V DC	250V AC, 50V DC	
Rated current	0.3, 0.5, 1, 2, 3, 5, 7, 10, 15, 20, 25, 30A	0.3, 0.5, 1, 2, 3, 5, 7, 10, 15, 20, 25, 30A	
Rated breaking capacity	2500A at 250V AC 1500A at 50V DC	1000A at 250V AC 1000A at 50V DC	
Operating characteristic	Time-delay tripping Instantaneous tripping Long time delay tripping	Time-delay tripping Instantaneous tripping Long time delay tripping	
Ambient temperature	-10°C to +60°C	-10°C to +60°C	
Dielectric strength	2000V AC 1min.	2000V AC 1min.	
Mechanical durability	10000 operations	6000 operations	
Electrical durability	10000 operations	6000 operations	
Mass	Approx. 100g	Approx. 100g (1-pole), 200g (2-pole)	

Note: Specify DC only when ordering circuit protectors for DC circuits.

■ Auxiliary switch

Main contact	Auxiliary contact	Auxiliary contact ratings	
ON 		250V AC	Resistive load: 1A Inductive load: 0.5A
OFF or Trip 		125V AC	Resistive load: 3A Inductive load: 1A
		50V DC	Resistive load: 1A Inductive load: 0.5A
		30V DC	Resistive load: 2A Inductive load: 1A

■ Characteristic curve

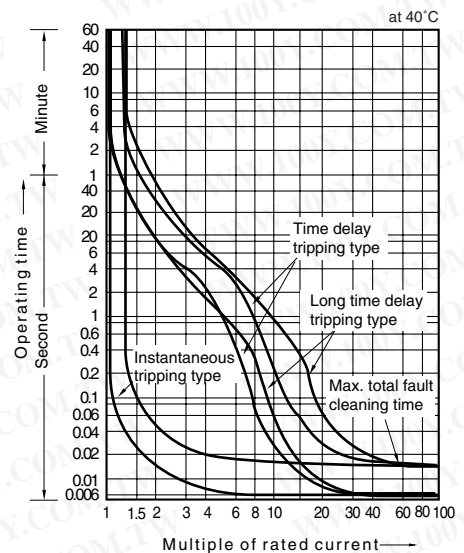

Ambient temperature compensation (Time delay tripping type)

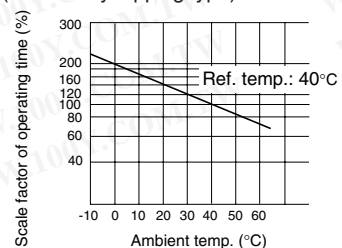

勝特力材料 886-3-5753170
勝特力电子(上海) 86-21-54151736
勝特力电子(深圳) 86-755-83298787
Http://www.100y.com.tw

■ Dimensions, mm
● CP31
Front mounting type

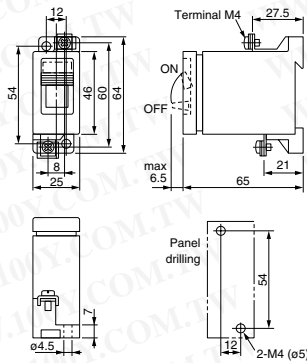

Mass: Approx. 100g

● CP31/W
With auxiliary switch

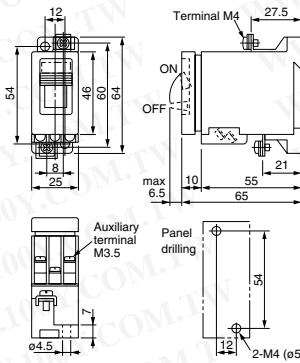

● CP31/X
Rail mounting type

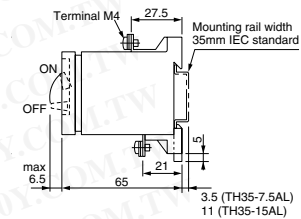

Mounting rail length: 900mm

Type	Material	Mounting pitch (Screw size)
TH35-7.5AL	Aluminium	200mm (M5)
TH35-15AL	Aluminium	400mm (M5)

Clamp TS-XT

● CP31D
Front mounting/Rail mounting type

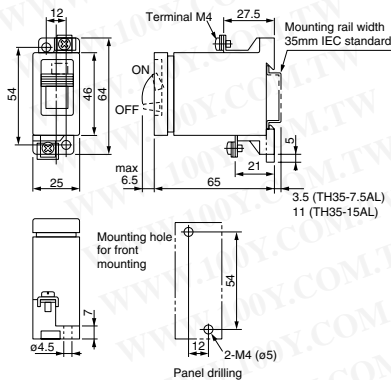

Mass: Approx. 100g

● CP31D/W
With auxiliary switch

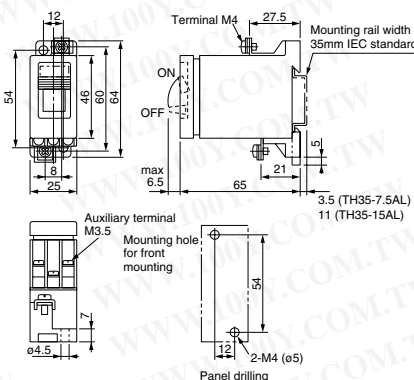

● CP31, CP31D
Flush mounting type

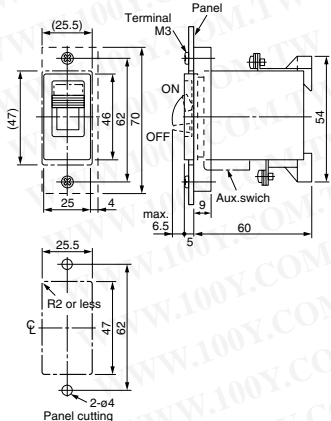

● CP32D
Front mounting/Rail mounting type

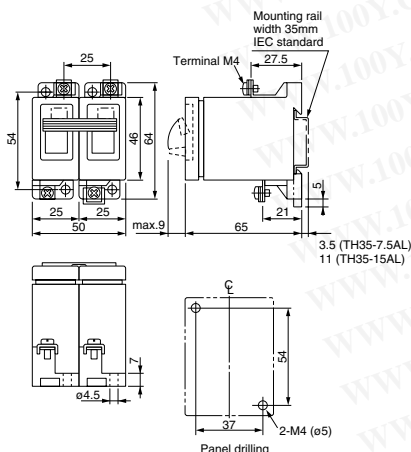

Mass: Approx. 200g

● CP32D/W
With auxiliary switch

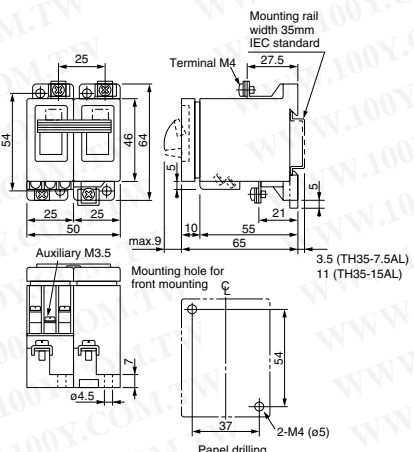

Size of conductors

Type of terminal	Main terminal	Auxiliary terminal
Terminal screw*	M4	M3.5
Connectable wire sizes	1.25–5.5mm ²	1.25–2mm ²
Max. width of applicable crimp terminal	9.8mm (R1.25–4 to R5.5–4)	6.8mm (R2–3.5)
Tightening torque	1.0–1.3N·m	0.8–0.9N·m

Note: * Terminal screws are the self-lifting to facilitate wiring.

■ Ordering information
Specify the following:
1. Type number