

FUSE CLIPS

FOR FERRULE FUSES / PC BOARD MOUNT



30A & 60A FERRULE - FUSE CLIPS

Fuse Clips for 30 & 60 Ampere Ferrule-type Fuses

CAT. NO.	FIG.	FOR FUSE RATING/SIZE:		MOUNTING DETAILS	
		AMPS (max.)	FERRULE DIA.	HOLE SIZE	SCREW SIZE
C08915P	1	30	13/32"	.172" dia.	#8
C08919P	2	30	13/32"	.196" dia.	#10
C08916P	3	30	9/16"	.172" dia.	#8
C08917P	4	30 or 60	13/16"	.22" x .30"	#10
C08918P	5	60	1-1/16"	.22" x .30"	#10

All clips are UL Recognized: Guide IZLT2, File E52283
 All clips are tin-plated copper alloy, non-spring reinforced.

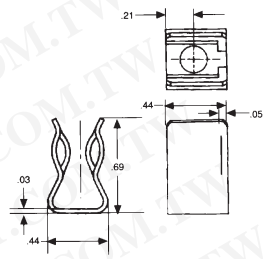

FIGURE 1

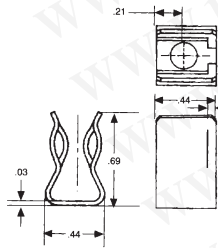

FIGURE 2

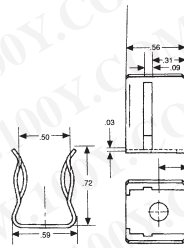

FIGURE 3

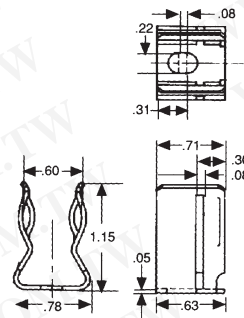

FIGURE 4

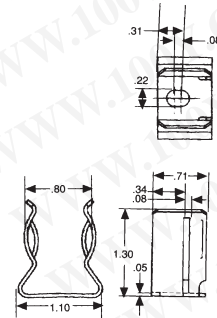
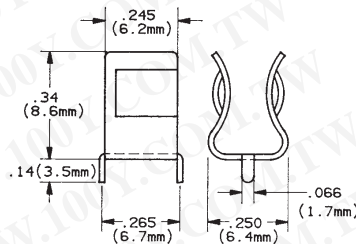

FIGURE 5



SDC6 PC BOARD CLIPS

- PC board mount fuse clip
- For 1/4" diameter fuses
- Tin plated hard brass



SDC5 PC BOARD CLIPS

- PC board mount fuse clip
- For 5mm diameter fuses
- Tin plated hard brass

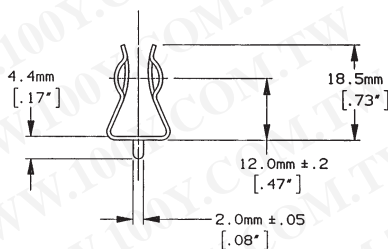

SDC7 PC BOARD CLIPS

- PC board mount fuse clip
- For 13/32" (10mm) diameter fuses
- Tin plated spring brass

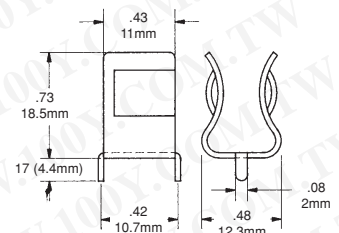

228-700 SERIES

MEDIUM VOLTAGE/FUSE CLIPS



Cat. No. 228-700-520
(Pair at bottom)

Cat. No. 228-700-530
(Single at top)

CLIP LOCK DESIGN FOR CL-14 SERIES

The Clip Lock design provides a reliable, high-pressure contact. Ferraz Shawmut CL-14 fuses have copper tabs which slide into position between the clip casting and cam. When the cam is locked by moving the pull ring, a high-pressure contact is made between the clip casting and fuse tab. Each clip includes two .44" diameter counter-sunk holes on 2" centers and two flat head socket screws (3/8-16 UNRC, recommended torque 200 pound-inches) for mounting the clip on standard NEMA insulators. These clips will accommodate 5kV and 15kV CL-14 fuses rated 10E to 600E. Order catalog number 228-700-520 for one pair of fuse clips, enough for one fuse.

勝特力材料 886-3-5753170
 勝特力电子(上海) 86-21-34970699
 勝特力电子(深圳) 86-755-83298787
[Http://www.100y.com.tw](http://www.100y.com.tw)

CL-14 Fuse Catalog Number	A Dimensions - Inches
A055C1DORO-(10E-150E)	13.25
A055C1DORO-(200E-400E)	19.25
A055C2DORO-(450E-600E)	19.25
A155C1DORO-(10E-50E)	19.25
A155C1DORO-(65E-100E)	19.25
A155C2DORO-(125E)	19.25
A155C3DORO-(150E-300E)	19.25

Mounting Details for Clip Lock Cat. No. 228-700-520

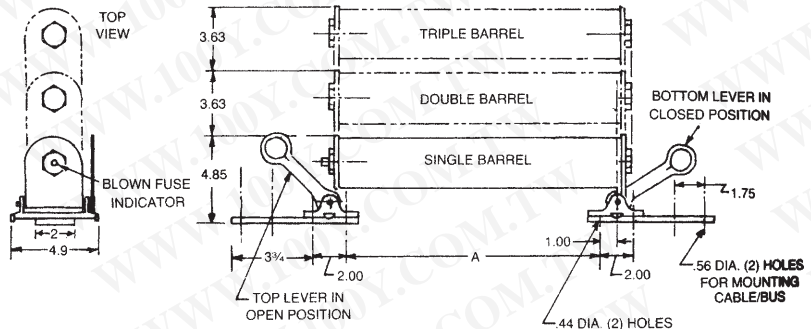

CLIPS FOR 3" DIAMETER FERRULE FUSES

These spring-reinforced clips will accommodate all 3" diameter, one and two barrel E-rated and R-rated medium voltage ferrule-type fuses. The clip and reinforcing spring are intended to be bolted to a copper bus bar through two .41" x 1.06" slots. A minimum copper-bus cross section of 1/4" x 1-1/2" is recommended for maximum fuse ratings of 24R and 450E. Catalog number is 228-700-530 for one pair of spring-reinforced clips, enough for one fuse.

Cat. No. 228-700-530

