

Manual Motor Starters

Optional accessories

勝特力材料 886-3-5753170
 勝特力电子(上海) 86-21-34970699
 勝特力电子(深圳) 86-755-83298787
[Http://www.100y.com.tw](http://www.100y.com.tw)

■ Features

- All accessories can be used with BM3R (45mm wide) and BM3V (55mm wide) frames.
- Accessories are easily mounted.
- Internal auxiliary contact blocks and alarm contact blocks can be mounted on front side.
- External auxiliary contact blocks can be mounted on either the right or left side.
- Shunt trip and undervoltage trip devices are available in a wide range of operating voltages.
- Standard and emergency external handles are available.
- IP20 terminal cover prevents accidental contact to electrically charged parts.

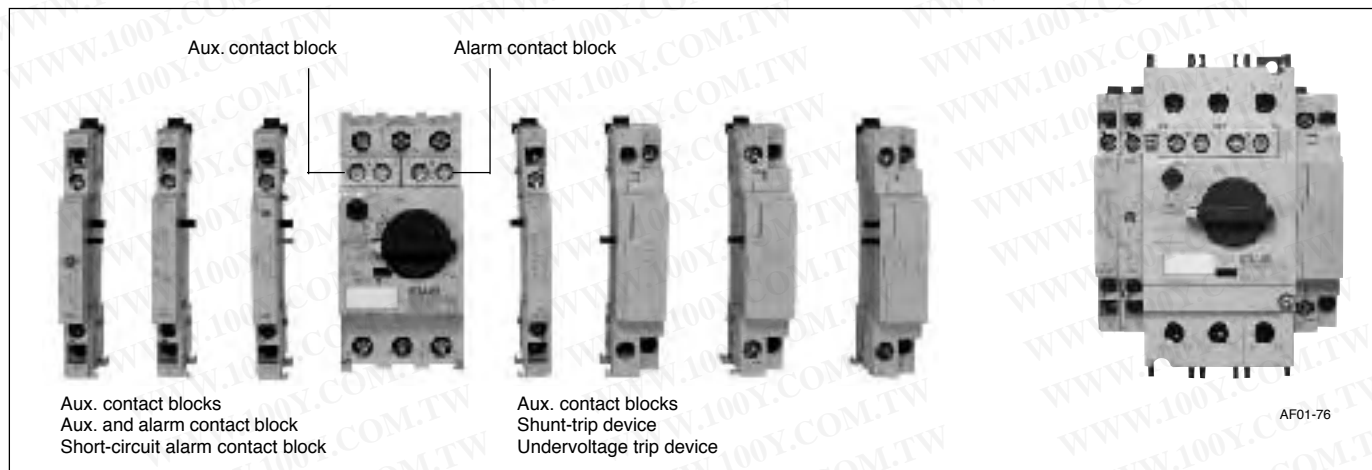

■ Part number and ratings

• Auxiliary contact blocks (W)

Description	Starter type	Mounting	Contact arrangement	Part number	Mass (g)
 <p>AF01-60L</p> <p>AF01-59, 01-58</p> <p>These blocks are linked to the ON/OFF operation of the MMS. Up to two contact blocks can be mounted to the right/left front, and up to two contact blocks can be mounted to the right/left sides.</p>	BM3R BM3V	Front	1NO 1NC	BZ0WIA BZ0WIB	9
		Left side	2NO 1NO+1NC 2NC	BZ0WUAAL BZ0WUABL BZ0WUBBL	45
		Right side	2NO 1NO+1NC 2NC	BZ0WUAAR BZ0WUABR BZ0WUBBR	45

• Alarm contact blocks (K)

Description	Starter type	Mounting	Contact arrangement	Part number	Mass (g)
 <p>AF01-60R</p> <p>This block operates when the MMS trips due to overload, phase-loss, or short-circuit. It is not linked to the ON/OFF operation of the MMS. Note: Operation can be checked with the test trip function.</p>	BM3R BM3V	Front (Right side only)	1NO 1NC	BZ0KIA BZ0KIB	9

Manual Motor Starters

Optional accessories

• Auxiliary and alarm contact blocks (WK)

Description	Starter type	Mounting	Contact arrangement	Part number	Mass (g)
 <p>This contact block combines auxiliary contact and alarm contact that operate in the event of an overload, phase loss, or short-circuit. Alarm contact is not linked to the ON/OFF operation of the MMS.</p> <p>An alarm is displayed in the contact block's indicator when the alarm contact operates.</p> <p>Note: Operation can be checked with the test trip function.</p>	BM3R BM3V	Left	1NO (Aux.)+ 1NO (Alarm)	BZ0WKUAA	45
			1NC (Aux.)+ 1NO (Alarm)	BZ0WKUBA	
			1NO (Aux.)+ 1NC (Alarm)	BZ0WKUAB	
			1NC (Aux.)+ 1NC (Alarm)	BZ0WKUBB	

• Short-circuit alarm contact block (KI)

Description	Starter type	Mounting	Contact arrangement	Part number	Mass (g)
 <p>The contacts operate only when the MMS has tripped due to a short-circuit.</p> <p>When these contacts operate, the blue reset button extends out, and a trip indication is displayed.</p> <p>The power to the MMS can be turned ON after pressing the reset button.</p> <p>Note: Operation can be checked with the test trip function. Be sure to press the reset button before mounting to the MMS.</p>	BM3R BM3V	Left	1NO+1NC	BZ0TKUAB	45

• Shunt trip devices (F)

Description	Starter type	Mounting	Coil voltage	Part number	Mass (g)
 <p>This device is used to remotely trip the MMS.</p> <p>Notes:</p> <ul style="list-style-type: none"> This device cannot be used together with an undervoltage trip device. When the MMS has been tripped with the shunt trip device, press the reset button before turning ON the power. 	BM3R BM3V	Right	24VAC 50/60Hz 48VAC 60Hz 48VAC 50Hz/60VAC 60Hz	BZ0FAZU BZ0FBZU BZ0FCZU	115
			100VAC 50Hz/100–110VAC 60Hz 110–127VAC 50Hz/120VAC 60Hz 200VAC 50Hz/200–220VAC 60Hz 220–230VAC 50Hz/240–260VAC 60Hz 240VAC 50Hz/277VAC 60Hz	BZ0F1ZU BZ0FDZU BZ0FEZU BZ0FFZU BZ0FGZU	
			380–400VAC 50Hz/400–440VAC 60Hz 415–440VAC 50Hz/460–480VAC 60Hz 500VAC 50Hz/600VAC 60Hz 24–60V DC * 110-240V DC *	BZ0FHZU BZ0F4ZU BZ0FJZU BZ0FKZUD BZ0FLZUD	

Note: * The time rating of coil is 5s.

• Undervoltage trip devices (R)

Description	Starter type	Mounting	Coil voltage	Part number	Mass (g)
 <p>R types This device automatically trips the MMS when the control circuit voltage drops below the specified value.</p> <p>Notes:</p> <ul style="list-style-type: none"> This device cannot be used together with a shunt trip device. When the MMS has been tripped with the undervoltage trip device, press the reset button before turning ON the power. 	BM3R BM3V	Right	24VAC 50Hz 24VAC 60Hz 48VAC 50Hz 48VAC 60Hz	BZ0RAZ1U BZ0RAZ2U BZ0RBZ1U BZ0RBZU	115
			100VAC 50Hz/100–110VAC 60Hz 110–127VAC 50Hz/120VAC 60Hz 200VAC 50Hz/200–220VAC 60Hz 220–230VAC 50Hz/240–260VAC 60Hz 240VAC 50Hz/277VAC 60Hz	BZ0R1ZU BZ0RDZU BZ0REZU BZ0RFZU BZ0RGZU	
			380–400VAC 50Hz/400–440VAC 60Hz 415–440VAC 50Hz/460–480VAC 60Hz 500VAC 50Hz/600VAC 60Hz	BZ0RHZU BZ0R4ZU BZ0RJZU	

Manual Motor Starters

Optional accessories

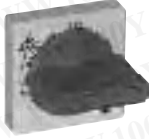

• External operating handles

Description	Starter type	Handle type	Part number	Mass (g)	
 <p>KK02-305</p> <ul style="list-style-type: none"> • Used to operate an MMS installed inside a panel, from the outside of the panel. • Equipped with an interlock mechanism that prevents someone from mistakenly opening the panel door when the MMS is in the ON state. • The shaft can be cut to match the distance between the MMS and the panel door. 	BM3RH	Standard (black)	BZ0VBBL	160	
		Emergency (red/yellow)	BZ0VYRL	160	
	 <p>KK02-306</p> <ul style="list-style-type: none"> • Door interlock function • OFF lock function • Can be locked OFF with up to three padlocks. Note: Padlocks not included. • Release screw allows the door to be opened with the handle in the ON position. • IP54 enclosure 	BM3V	Standard (black)	BZ0VBBM	160
			Emergency (red/yellow)	BZ0VYRM	160

• Line side terminal cover

Description	Starter type	Part number	Mass (g)
 <p>Used for making Type E or Type F condition</p>	BM3R	BZ0TCRE	30

• Others

Description	Starter type	Part number	Mass (g)
<p>Push-in lug</p>  <p>Used for screw mounting. 10 pcs/pack</p>	BM3R	BZ0SET	2.0
<p>Terminal cover for IP20</p>  <p>Prevents accidental contact to charged parts. 6 pcs/pack</p>	BM3V	BZ0TCV	0.6
<p>Dummy cover</p>  <p>KK02-39</p> <ul style="list-style-type: none"> • Used to cover the open space if an internally mounted accessory should become unnecessary. • Mounts to either the left-front or right-front position. • 10 pcs/pack 	BM3R BM3V	BZ0CFG	1.4

Manual Motor Starters

Optional accessories

■ Ratings of accessories

Accessory type		Auxiliary contact block/front	Auxiliary contact block/side	Alarm contact block	Aux. and alarm contact block	Short-circuit alarm contact block
Part number		BZ0WI	BZ0WU	BZ0KI	BZ0WKU	BZ0TKUAB
Standard		IEC 60947-5-1, UL 508				
Rated operational current (A)	48V AC AC-15	5	6	5	6	6
	125V AC	3	4	3	4	4
	230V AC	1.5	4	1.5	4	4
	400V AC	–	2.2	–	2.2	2.2
	500V AC	–	1.5	–	1.5	1.5
	690V AC	–	0.6	–	0.6	0.6
	48V DC DC-13	1.38	5	1.38	5	5
110V DC	0.55	1.3	0.55	1.3	1.3	
220V DC	0.27	0.5	0.27	0.5	0.5	
Contact rating code UL 508		B300 Q300	A600 P300	B300 Q300	A600 P300	A600 P300
Min. voltage and current		17V 5mA				

Accessory type		Shunt trip device	Undervoltage device
Part number		BZ0F	BZ0R
Standard		IEC 60947-1, UL 508	
Rated insulation voltage (V AC)	IEC 60947	690	
	UL 508	600	
No. of ON-OFF operations		5000	
Operating time (ms)		20	
Power consumption	Inrush (VA/W)	21/12	
	Sealed (VA/W)	8/1.2	
Voltage range	Tripping voltage (V)	0.7 to 1.1Ue	0.35 to 0.7Ue
	Closing voltage (V)	–	0.85 to 1.1Ue
Time rating of coil (s)		AC: Continuous DC: 5	AC: Continuous

Note: Ue: Rated Voltage

Manual Motor Starters

Optional accessories

Available accessory configuration

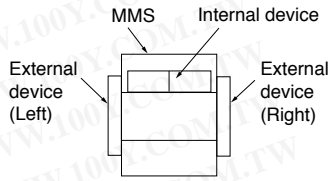

Internal devices

- Auxiliary contact block (W)
- Alarm contact block (K)

External devices

- Auxiliary contact (W2)
- Auxiliary and alarm contact block (WK)
- Short-circuit alarm contact block (KI)
- Shunt trip device (F)
- Undervoltage trip device (R)

Adj. thermal-magnetic trip type MMS		BM3RSB, BM3RHB						BM3VSB, BM3VHB					
Internal accessory													
		W	W	K	W+W	W+K	W	W	K	W+W	W+K		
External accessory	W2 (Left)												
	W2 (Right)												
	WK (Left)												
	KI (Left)												
	F (Right)												
	R (Right)												
	W2 (Left)+F												
	W2 (Left)+R												
	WK+F												
	WK+R												
	KI+F												
	KI+R												
W2 (Left)+W2 (Left)													
W2 (Left)+W2 (Right)													

Manual Motor Starters

Optional accessories

Available accessory configuration (continued)

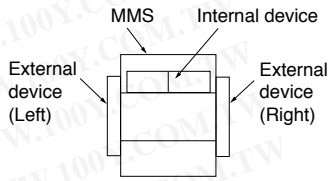

Internal devices

Auxiliary contact block (W) Alarm contact block (K)

External devices

Auxiliary contact (W2) Auxiliary and alarm contact block (WK) Short-circuit alarm contact block (KI)
 Shunt trip device (F) Undervoltage trip device (R)

Adj. thermal-magnetic trip type MMS		BM3RSB, BM3RHB						BM3VSB, BM3VHB					
Internal accessory													
External accessory	W2 (Right)+ W2 (Right)												
	W2 (Left)+ WK												
	W2 (Right)+ WK												
	W2 (Left)+ KI												
	W2 (Right)+ KI												
	KI+WK												
	W2 (Left)+ W2 (Left)+F												
	W2 (Left)+ W2 (Left)+R												
	W2 (Left)+ WK+F												
	W2 (Left)+ WK+R												
	W2 (Left)+ KI+F												
	W2 (Left)+ KI+R												
	KI+WK+F												
	KI+WK+R												

Manual Motor Starters

Dimensions

■ Dimensions, mm

Accessories

- Auxiliary contact blocks, front mounting
BZ0W1

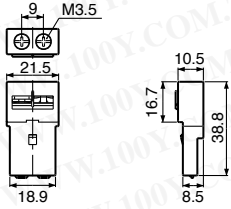

- Auxiliary contact blocks, side mounting
BZ0WU

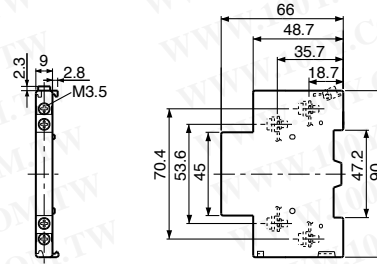

- Alarm contact blocks, front mounting
BZ0K1

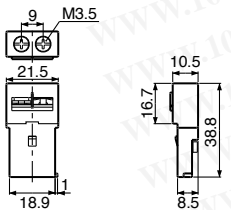

- Auxiliary and alarm contact blocks
BZ0WKU

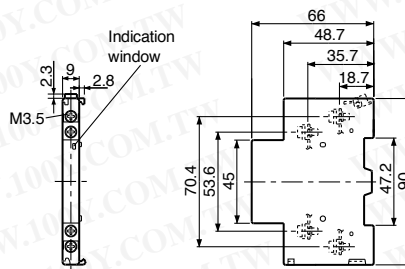

Manual Motor Starters Dimensions

■ Dimensions, mm

Accessories

- Short-circuit alarm contact block
BZ0TKUAB

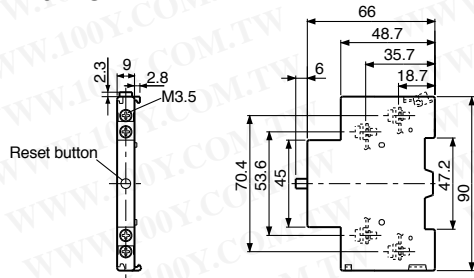

- Shunt trip devices BZ0F
Undervoltage trip devices BZ0R

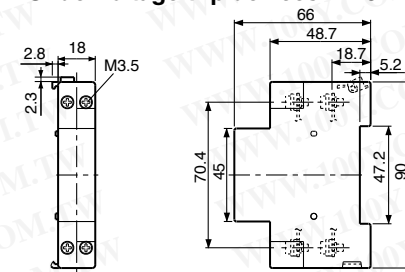

- BZ0TCRE

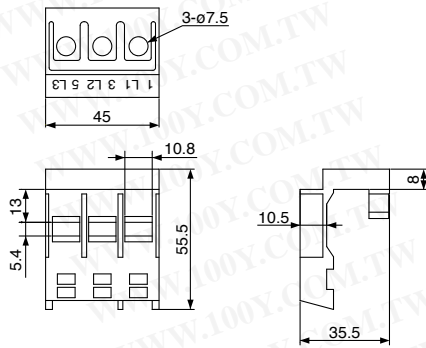

MMS with accessories

- BM3RSB + BZ0

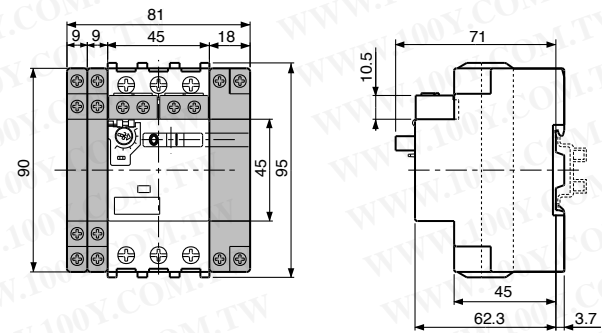

- BM3RHB + BZ0

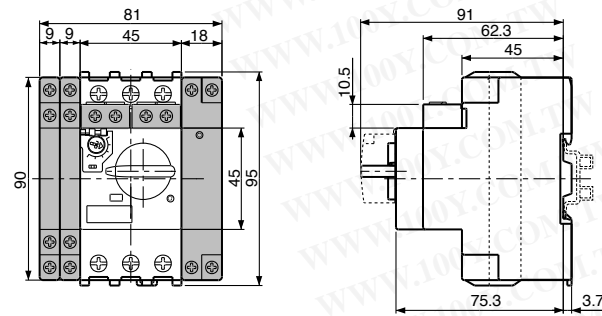

- BM3V□B + BZ0

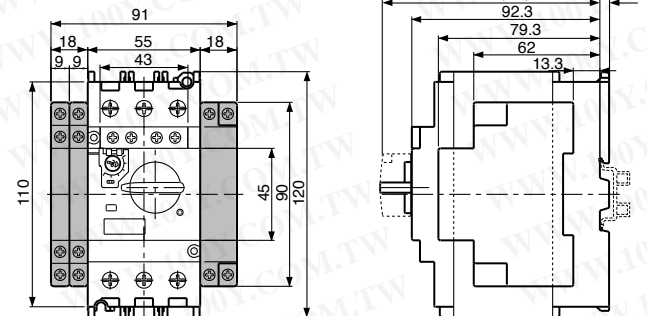

External operation handle BZ0V

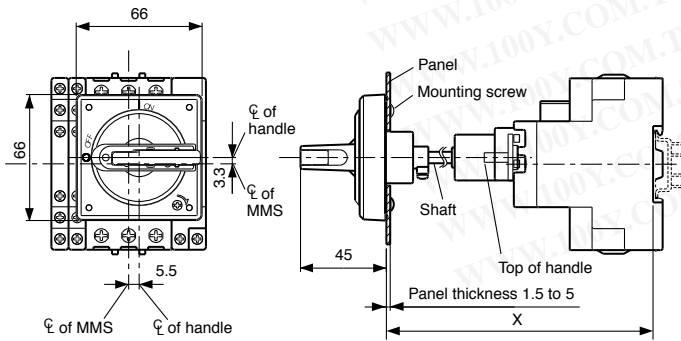

Panel drilling

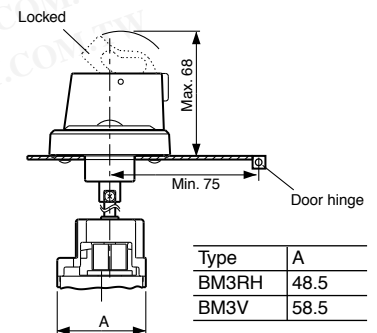
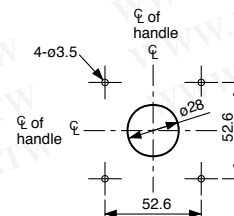

Type	X min.	X max.
BZ0VBBL, BZ0VYRL	139 ±2	289 ±2
BZ0VBBM, BZ0VYRM	156 ±2	306 ±2

Type	A
BM3RH	48.5
BM3V	58.5

Manual Motor Starters Dimensions

Wiring diagrams

MMS

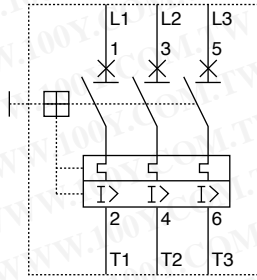

Auxiliary contact blocks

Front mounting

BZ0WIA

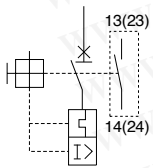

BZ0WIB

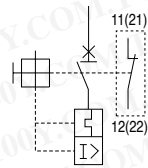

Alarm contact blocks

Front mounting

BZ0KIA

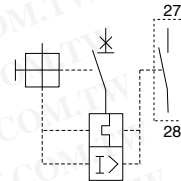

BZ0KIB

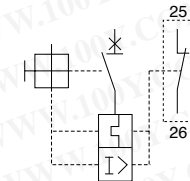

Side mounting

BZ0WUAAAL

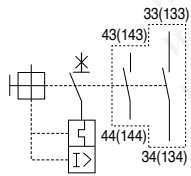

BZ0WUABL

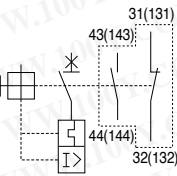

BZ0WUBBL

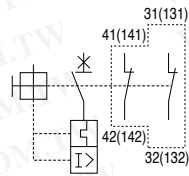

Auxiliary and alarm contact blocks

BZ0WKUAA

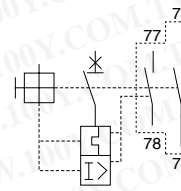

BZ0WKUBA

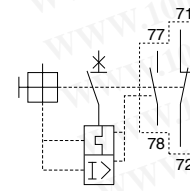

BZ0WUAAR

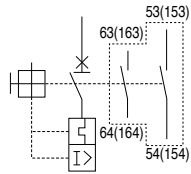

BZ0WUABR

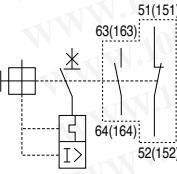

BZ0WUBBR

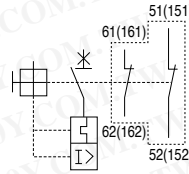

BZ0WKUAB

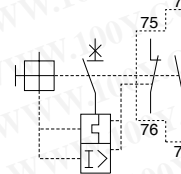

BZ0WKUBB

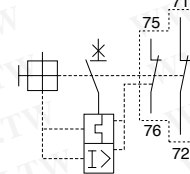

Short-circuit alarm contact blocks

BZ0TKUAB

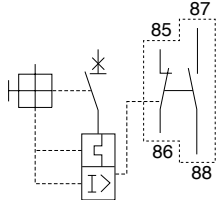

Shunt trip devices

BZ0F

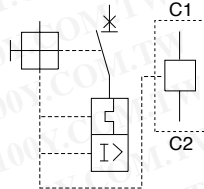

Undervoltage trip devices

BZ0R

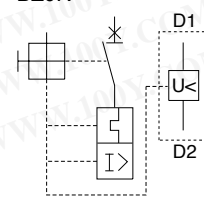

Manual Motor Starters Busbar system

Features

- The busbar system reduces wiring time and saves floorspace.
- The busbar makes it easy to power from 2 to 5 manual motor starters – with no wiring needed.
- The 3-phase feed-in terminals are used to connect the wire for the power supply circuit.
- The busbar cover guards against accidental contact with non-connected busbar terminals (charged parts).

<Note>

If using BZ0TCRE terminal cover with BM3R series MMS, the busbar system can not be used.

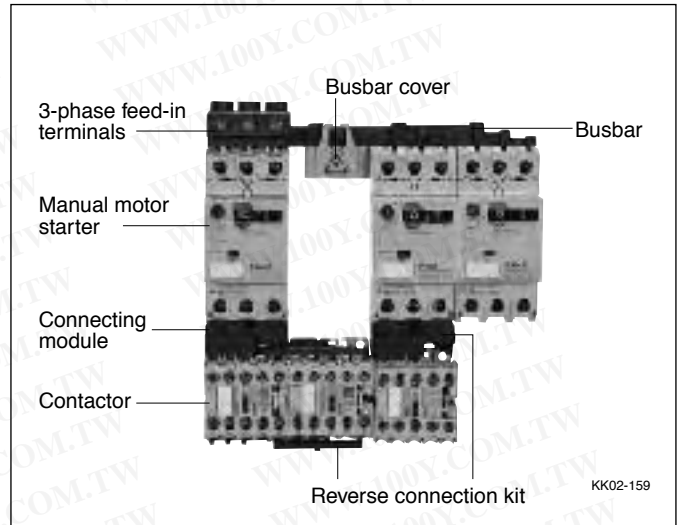

Part number and ratings

Description	Used with	Specification	Part number	Mass (g)
 KK02-164	BM3R	Continuous current: 64A max. Pin connection	2-BM3R, modular space: 45mm 3-BM3R, modular space: 45mm 4-BM3R, modular space: 45mm 5-BM3R, modular space: 45mm	BZ0BR02A 30 BZ0BR03A 50 BZ0BR04A 70 BZ0BR05A 90
	BM3R+1-external accessory, 9mm wide		2-BM3R, modular space: 54mm 3-BM3R, modular space: 54mm 4-BM3R, modular space: 54mm 5-BM3R, modular space: 54mm	BZ0BR12A 30 BZ0BR13A 55 BZ0BR14A 80 BZ0BR15A 105
	BM3R+2-external accessory, 9mm wide or BM3R+1-external accessory, 18mm wide	Continuous current: 64A max. Fork connection	2-BM3R, modular space: 63mm 4-BM3R, modular space: 63mm	BZ0BR22A 45 BZ0BR24A 100
	BM3V	Continuous current: 126A max. Pin connection	2-BM3V, modular space: 55mm 3-BM3V, modular space: 55mm 4-BM3V, modular space: 55mm	BZ0BV02A 140 BZ0BV03A 240 BZ0BV04A 340
	BM3V+1-external accessory, 9mm wide		2-BM3V, modular space: 64mm 3-BM3V, modular space: 64mm 4-BM3V, modular space: 64mm	BZ0BV12A 150 BZ0BV13A 270 BZ0BV14A 380
	BM3V+2-external accessory, 9mm wide or BM3V+1-external accessory, 18mm wide		2-BM3V, modular space: 73mm 4-BM3V, modular space: 73mm	BZ0BV22A 165 BZ0BV24A 425
 AF01-70R	BM3R	Continuous current: 64A max. Applicable cable size: 25mm ² max.	BZ0BFRA	40
	BM3V	Continuous current: 126A max. Applicable cable size: 50mm ² max.	BZ0BFVA	170
 AF01-70L	BZ0BR	For pin connection For fork connection	BZ0BCRA BZ0BCRB	10 5
	BZ0BV	For pin connection	BZ0BCVA	5

Manual Motor Starters

Busbar system

■ Dimensions, mm

• For BM3R

BZ0BR0 Without external accessory

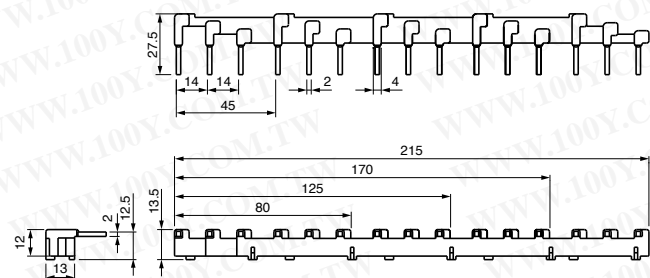

BZ0BR02A: 80mm
 BZ0BR03A: 125mm
 BZ0BR04A: 170mm
 BZ0BR05A: 215mm

• For BM3V

BZ0BV0 Without external accessory

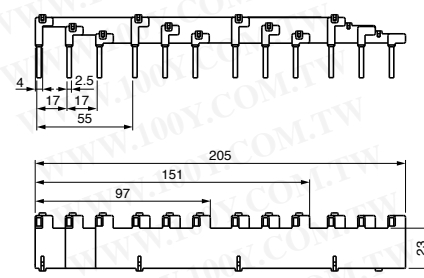

BZ0BV02A: 97mm
 BZ0BV03A: 151mm
 BZ0BV04A: 205mm

BZ0BR1 With 1-external accessory

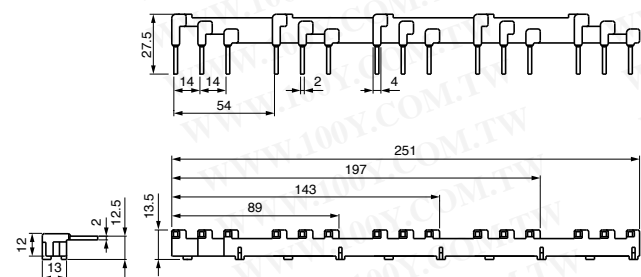

BZ0BR12A: 89mm
 BZ0BR13A: 143mm
 BZ0BR14A: 197mm
 BZ0BR15A: 251mm

BZ0BV1 With 1-external accessory, 9mm wide

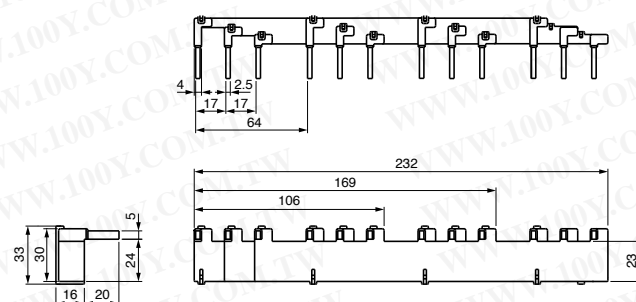

BZ0BV12A: 106mm
 BZ0BV13A: 169mm
 BZ0BV14A: 232mm

BZ0BR2 With 2-external accessory, 9mm wide
 With 1-external accessory, 18mm wide

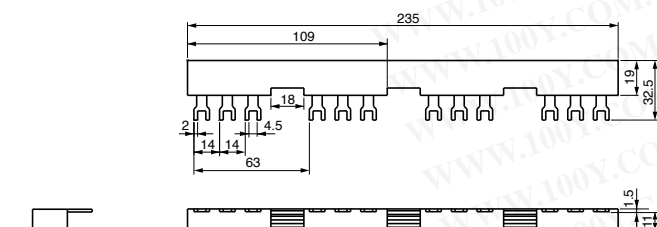

BZ0BR22A: 109mm
 BZ0BR24A: 235mm

BZ0BV2 With 2-external accessory, 9mm wide
 With 1-external accessory, 18mm wide

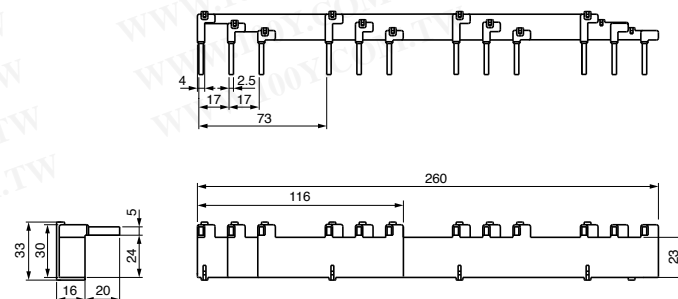

BZ0BV22A: 116mm
 BZ0BV24A: 260mm

Manual Motor Starters

Busbar system

■ Dimensions, mm

- 3-phase feed-in terminals

BZ0BFRA

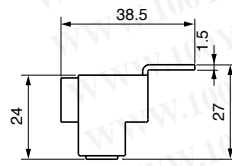
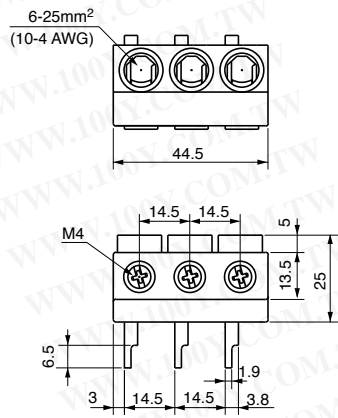

BZ0BFVA

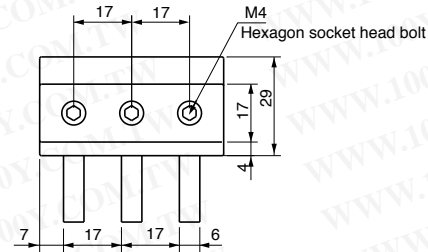
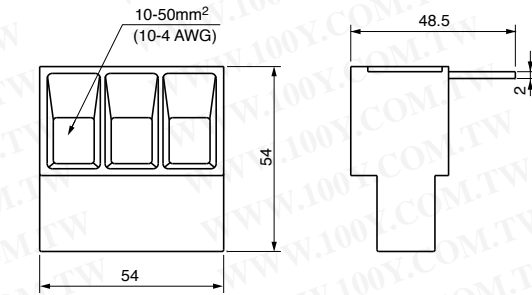

Manual Motor Starters Enclosures

■ Features

- Accommodates a variety of manual motor starters (BM3RSB-P16 to 025). Put the manual motor starter inside an enclosure for use in harsh environments. Surface mounting and flush mounting types available.
- IP41 and IP55 enclosure protection degree available.
- Manual motor starters (BM3RSB-P16 to 025) equipped with internal accessories and the following external accessories can be used inside an enclosure.
 - Left side: One auxiliary contact block (W) or one auxiliary and alarm contact block (WK)
 - Right side: One shunt trip device (F) or one undervoltage trip device (R)
- A wide variety of enclosure accessories are available. Padlocking device, emergency mushroom head pushbutton, conversion kit, and indicator lamps.

■ Part number and ratings

Enclosures for BM3RSB-P16 to 025

Mounting	Specification	Part number	Mass (g)
Surface	IP41	BZ0CSLA	320
	IP55 (with conversion kit)	BZ0CSLB	340
Flush	IP41	BZ0CFLA	240
	IP55 (with conversion kit)	BZ0CFLB	260

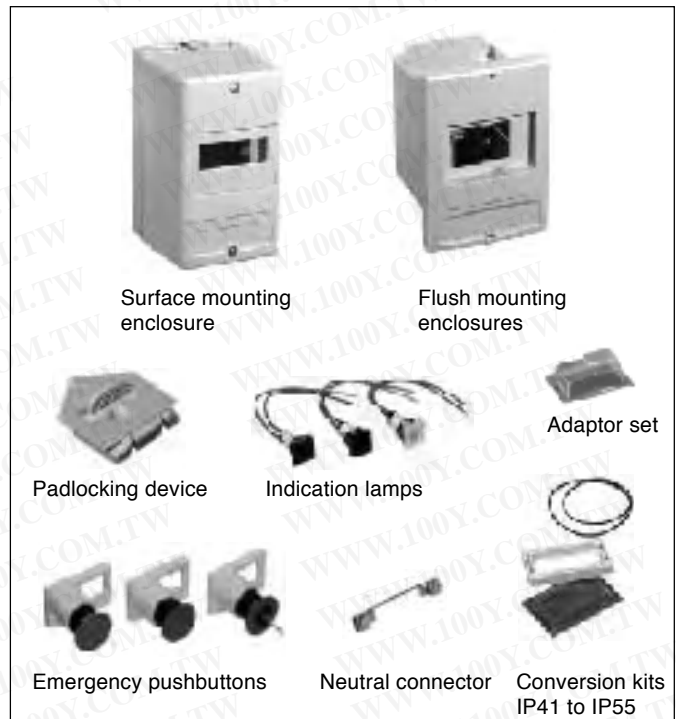

Accessories for enclosures

Description	Specification	Part number	Mass (g)
Padlocking device	OFF locking possible using up to three padlocks with a 5 to 8mm shackle diameter.	BZ0CKA	90
Emergency pushbutton	Momentary Push-lock turn reset Key operated	BZ0CPM	55
		BZ0CPL	55
		BZ0CPK	90
Conversion kit	Converts IP41 to IP55	BZ0CCA	25
Adaptor set	For BM3RS + undervoltage trip device with auxiliary contact.	BZ0CUA	20
Neutral connector	Used inside the enclosure for neutral and ground connection.	BZ0CNA	10
Indication lamp	Green, 100–120V AC	BZ0CLGA	15
	Green, 200–240V AC	BZ0CLGB	15
	Green, 380–440V AC	BZ0CLGC	15
	Green, 480–500V AC	BZ0CLGD	15
	Green, 500–600V AC	BZ0CLGE	15
	Red, 100–120V AC	BZ0CLRA	15
	Red, 200–240V AC	BZ0CLRB	15
	Red, 380–440V AC	BZ0CLRC	15
	Red, 480–500V AC	BZ0CLRD	15
	Red, 500–600V AC	BZ0CLRE	15
	White, 100–120V AC	BZ0CLCA	15
	White, 200–240V AC	BZ0CLCB	15
	White, 380–440V AC	BZ0CLCC	15
	White, 480–500V AC	BZ0CLCD	15
	White, 500–600V AC	BZ0CLCE	15

Notes: • The padlocking device cannot be used together with the emergency pushbutton or undervoltage trip device with auxiliary contact.
• The emergency pushbutton cannot be used together with the undervoltage trip device with auxiliary contact.

勝特力材料 886-3-5753170

勝特力电子(上海) 86-21-34970699

勝特力电子(深圳) 86-755-83298787

Http://www.100y.com.tw

Manual Motor Starters Dimensions

■ Dimensions, mm

• Surface mounting
For without accessory

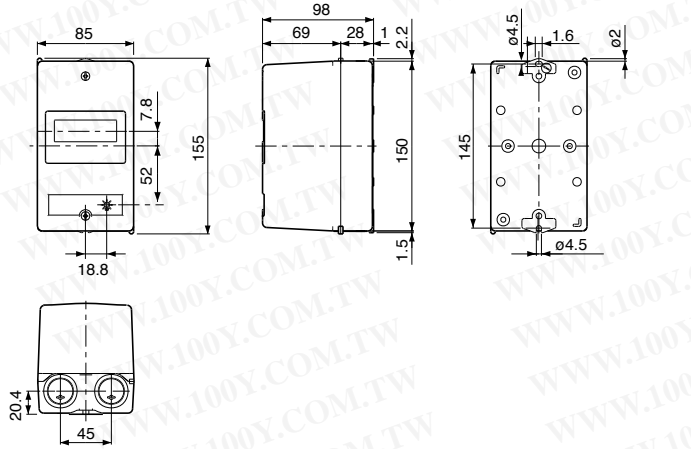

• Flush mounting
For without accessory

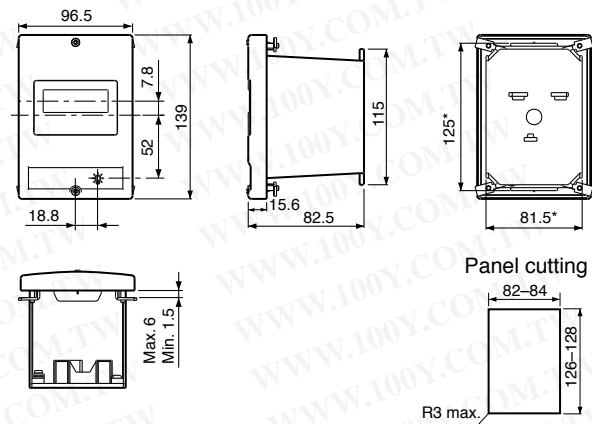

For with padlocking device

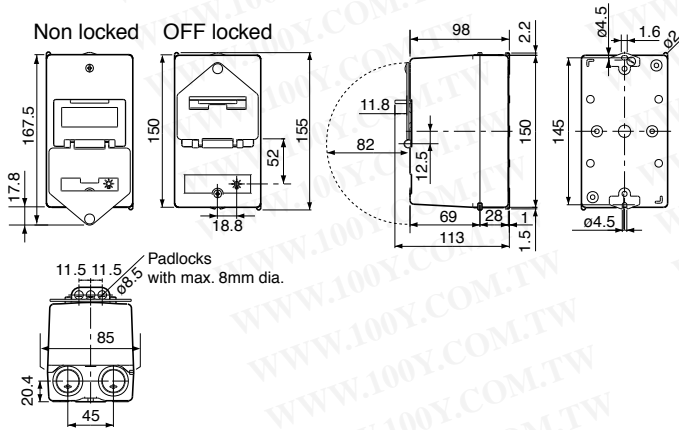

For with padlocking device

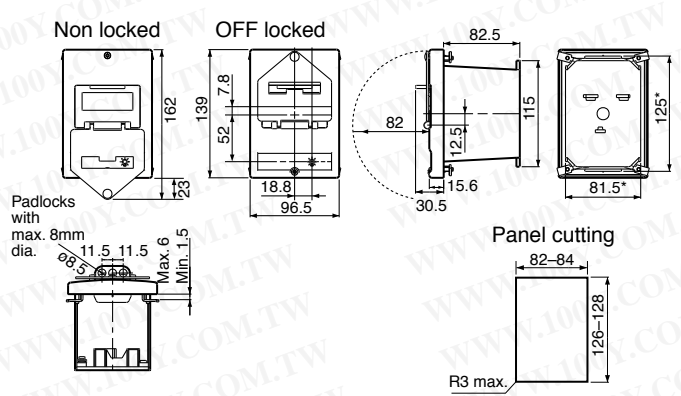

For with emergency pushbutton

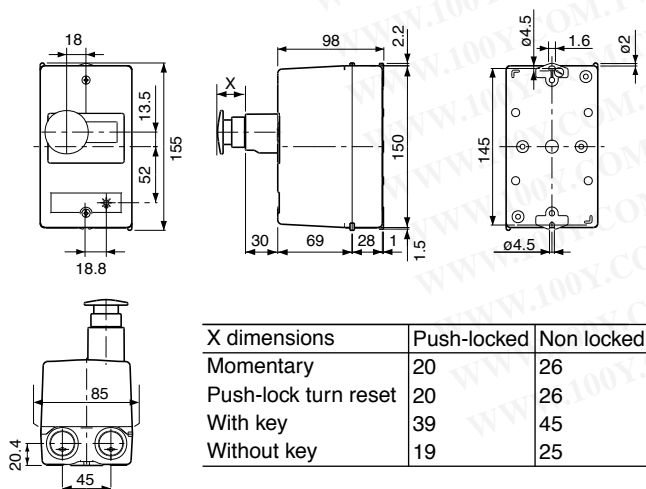

X dimensions	Push-locked	Non locked
Momentary	20	26
Push-lock turn reset	20	26
With key	39	45
Without key	19	25

For with emergency pushbutton

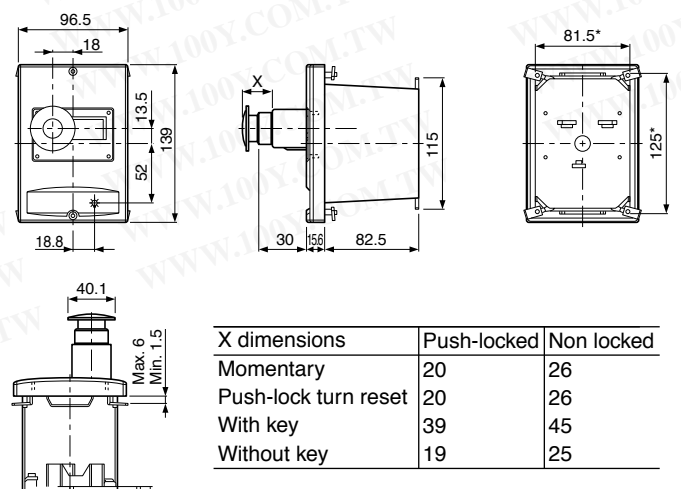

X dimensions	Push-locked	Non locked
Momentary	20	26
Push-lock turn reset	20	26
With key	39	45
Without key	19	25

Panel cutting

