

CATALOG NO.	TERMINAL TYPE	IP20 FINGER SAFE C		NO. OF POLES
		W/O INDICATION	INDICATION	
RM25030-1SR	SCREW	CVR-RH-25030	CVRI-RH-25030	1
RM25030-2SR	SCREW			2
RM25030-3SR	SCREW			3
RM25030-1PR	PRESSURE PLATE			1
RM25030-2PR	PRESSURE PLATE			2
RM25030-3PR	PRESSURE PLATE			3
RM25030-1CR*	BOX LUG	CVR-RH-25030	CVRI-RH-25030	1
RM25030-2CR*	BOX LUG			2
RM25030-3CR*	BOX LUG			3
RM25030-1QR	SCREW AND .187 QUICK CONNECTS			1
RM25030-2QR	SCREW AND .187 QUICK CONNECTS			2
RM25030-3QR	SCREW AND .187 QUICK CONNECTS			3

勝特力材料 886-3-5753170  
 勝特力电子(上海) 86-21-34970699  
 勝特力电子(深圳) 86-755-83298787  
[Http://www.100y.com.tw](http://www.100y.com.tw)

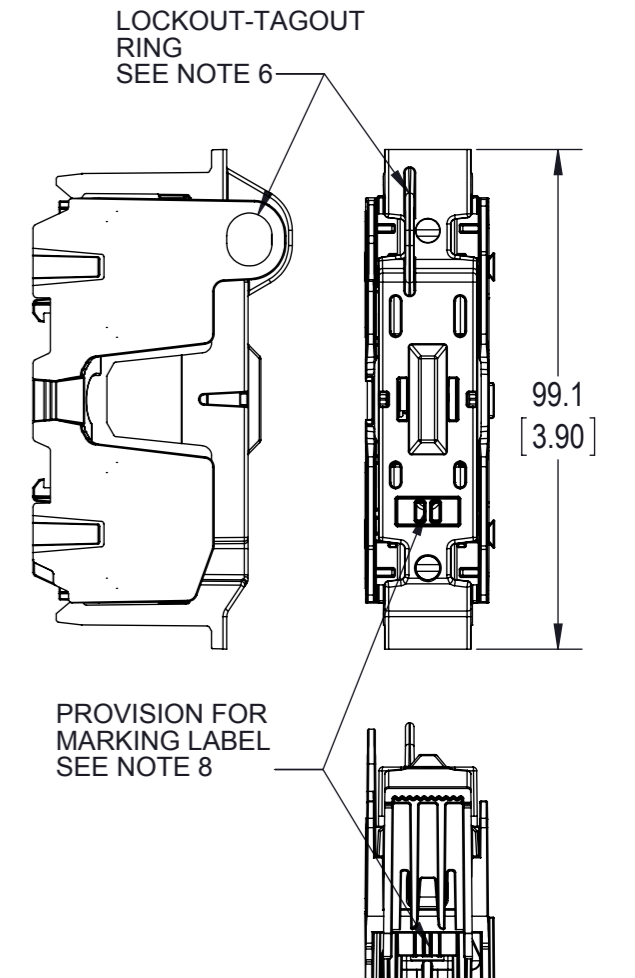

RM25030-1SR    RM25030-1PR    RM25030-1QR    1-POLE RM25030-1CR SHOWN    2-POLE RM25030-2CR SHOWN    3-POLE RM25030-3CR SHOWN    RM25030-1CR SHOWN WITH COVER

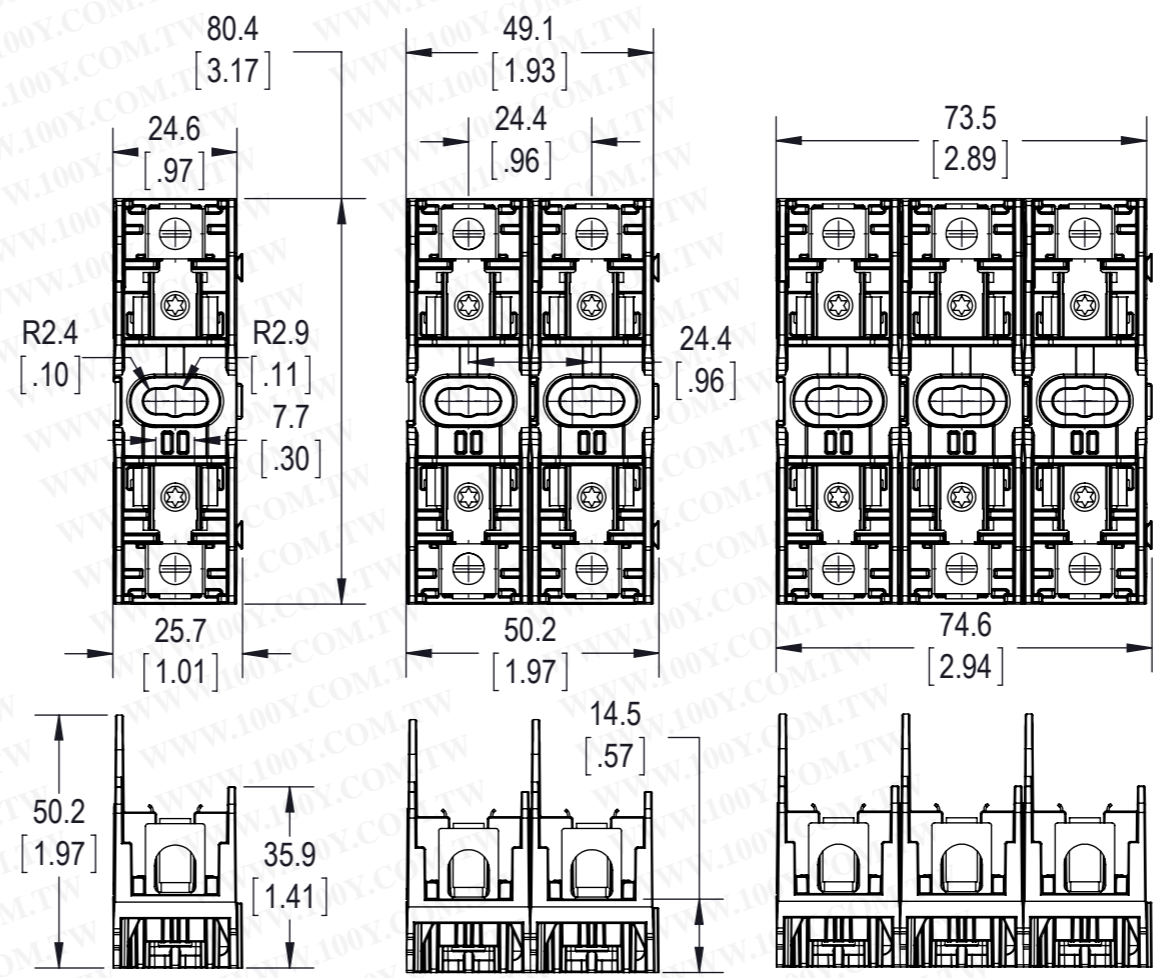
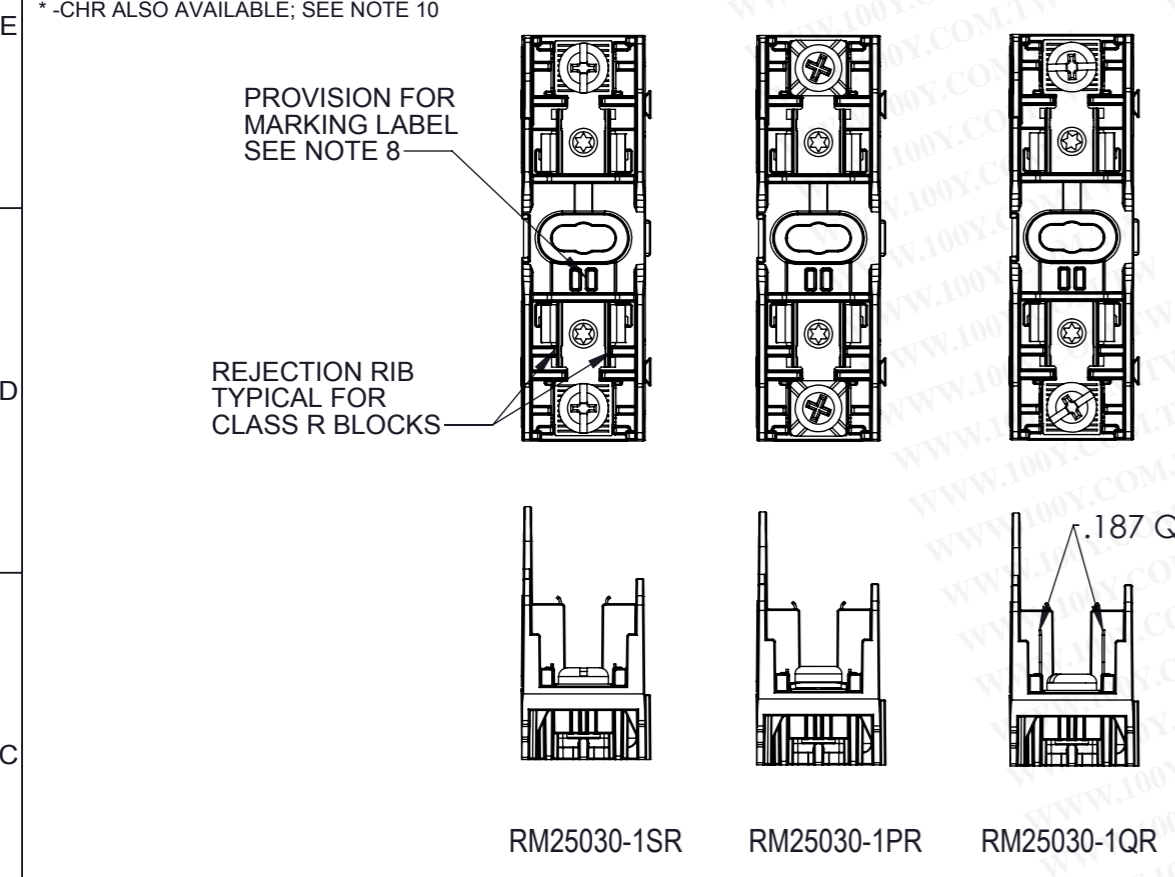
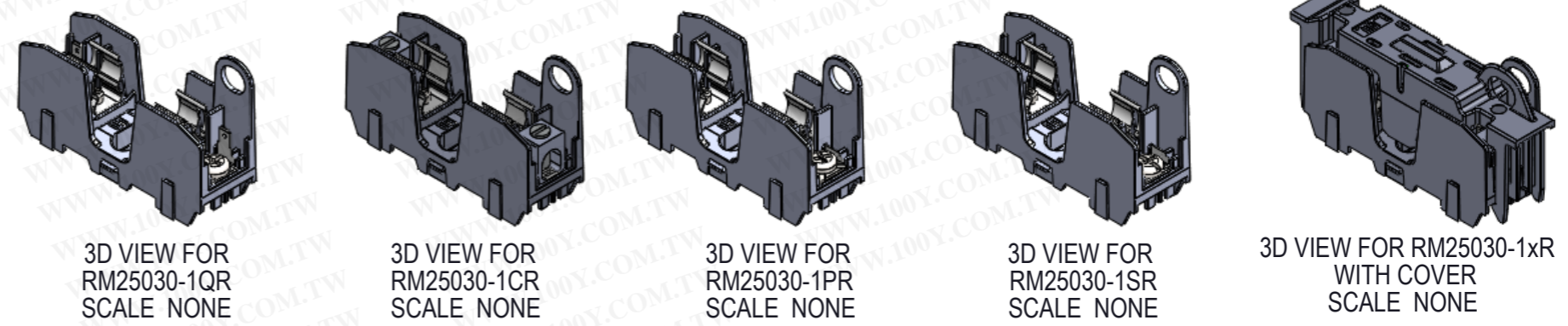

- NOTES:
- VOLTAGE RATING: 250V
  - AMPERAGE: 30A
  - WITHSTAND RATING: CLASS R = 200kA; CLASS H = 10kA
  - WIRE: CU75C/90C
  - CR WIRE RANGE:
    - 2 - 14 AWG CU  
2-3: 50 lb-in (5.6 Nm)  
4-6, 45 lb-in (5.1 Nm)  
8, 40 lb-in (4.5 Nm)  
10-14, 35 lb-in (4.0 Nm)
    - 12-14, 50 lb-in (5.6 Nm)
  - 2 - 8 AWG AL  
2-3: 50 lb-in (5.6 Nm)  
4-6, 45 lb-in (5.1 Nm)  
8, 40 lb-in (4.5 Nm)
  - SR/PR WIRE RANGE: (1) 10-18 AWG CU ONLY  
10-18 AWG = 20 LB-IN (2.3NM)
  - USE 4MM DIA. CABLE LOCK OR 1/4 INCH DIA. HASP PADLOCK.
  - RECOMMEND USING DIN-RAIL END STOPS FOR DIN RAIL MOUNTED APPLICATIONS  
BUSSMANN PART NUMBERS BRKT-ND OR BRKT-NDSCREW2
  - USE BUSMANN MAKER LABEL TM26CB
  - ALL DIMENSIONS ARE TYPICAL UNLESS OTHERWISE INDICATED
  - CHR IS IDENTICAL TO THE -CR EXCEPT WITH A 1/8 INCH HEX WIRE CONNECTOR SCREW

EATON CORPORATION - CONFIDENTIAL AND PROPRIETARY NOTICE TO PERSONS RECEIVING THIS DOCUMENT AND/OR TECHNICAL INFORMATION <small>THIS DOCUMENT, INCLUDING THE DRAWING AND INFORMATION CONTAINED THEREON, IS CONFIDENTIAL AND IS THE EXCLUSIVE PROPERTY OF EATON CORPORATION AND IS MERELY ON LOAN AND SUBJECT TO RECALL BY EATON AT ANY TIME. BY TAKING POSSESSION OF THE DOCUMENT, THE RECIPIENT ACKNOWLEDGES AND AGREES THAT THIS DOCUMENT CANNOT BE USED IN ANY MANNER ADVERSE TO THE INTERESTS OF EATON AND THAT NO PORTION OF THIS DOCUMENT MAY BE COPIED OR OTHERWISE REPRODUCED WITHOUT THE PRIOR WRITTEN CONSENT OF EATON. IN THE CASE OF CONFLICTING CONTRACTUAL PROVISIONS, THIS NOTICE SHALL GOVERN THE STATUS OF THIS DOCUMENT.</small> © 2012 Eaton Corporation, All Rights Reserved.	THIS DRAWING IS AN UNCONTROLLED COPY IF PRINTED OR SENT ELECTRONICALLY. DO NOT SCALE DRAWING GENERAL DRAWING PRACTICES IN ACCORDANCE WITH ASME - Y14.100-2004 DIMENSIONS AND TOLERANCES IN ACCORDANCE WITH ASME - Y14.5M-1994 UNLESS OTHERWISE SPECIFIED DIMENSIONS ARE IN MILLIMETERS UNLESS OTHERWISE SPECIFIED TOLERANCES TO BE MILLIMETERS ±.13 mm ANGULAR ± 1°	
	<b>CUSTOMER PRINT</b> THIRD ANGLE PROJECTION	

CATALOG NO.	TERMINAL TYPE	IP20 FINGER SAFE C		NO. OF POLES
		W/O INDICATION	INDICATION	
HM25030-1SR	SCREW	CVR-RH-25030	CVRI-RH-25030	1
HM25030-2SR	SCREW			2
HM25030-3SR	SCREW			3
HM25030-1PR	PRESSURE PLATE			1
HM25030-2PR	PRESSURE PLATE			2
HM25030-3PR	PRESSURE PLATE			3
HM25030-1CR*	BOX LUG			1
HM25030-2CR*	BOX LUG			2
HM60030-3CR*	BOX LUG			3
HM25030-1QR	SCREW AND .187 QUICK CONNECTS			1
HM25030-2QR	SCREW AND .187 QUICK CONNECTS	2		
HM25030-3QR	SCREW AND .187 QUICK CONNECTS	3		

\* -CHR ALSO AVAILABLE; SEE NOTE 10

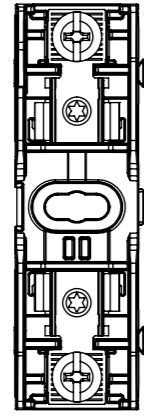

HM25030-1SR

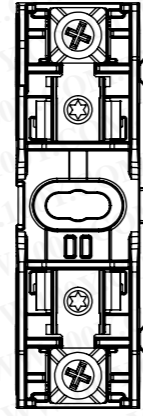

HM25030-1PR

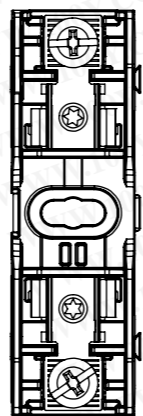

HM25030-1QR

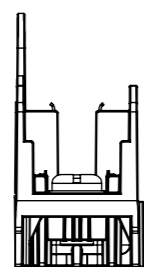

HM25030-1CR SHOWN

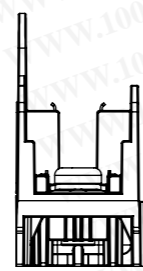

2-POLE  
HM25030-2CR SHOWN

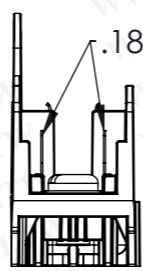

3-POLE  
HM25030-3CR SHOWN

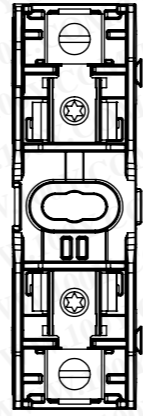

1-POLE  
HM25030-1CR SHOWN

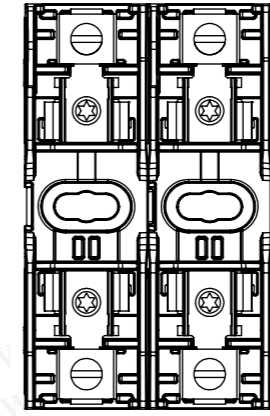

2-POLE  
HM25030-2CR SHOWN

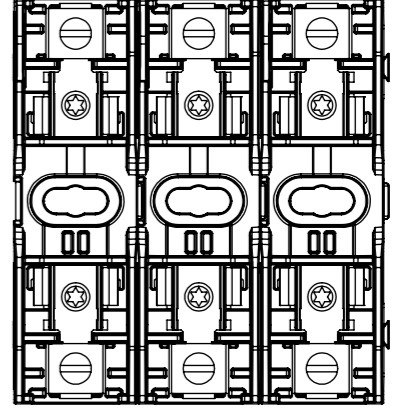

3-POLE  
HM25030-3CR SHOWN

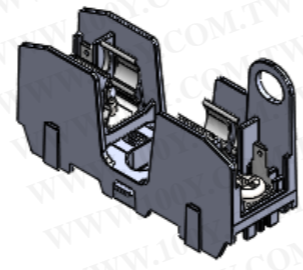

3D VIEW FOR  
HM25030-1QR  
SCALE NONE

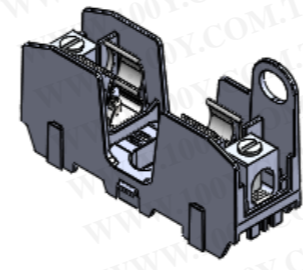

3D VIEW FOR  
HM25030-1CR  
SCALE NONE

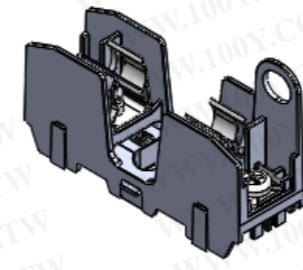

3D VIEW FOR  
HM25030-1PR  
SCALE NONE

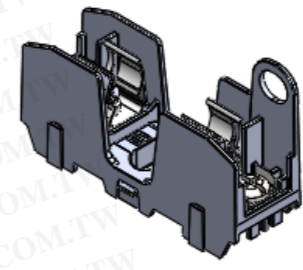

3D VIEW FOR  
HM25030-1SR  
SCALE NONE

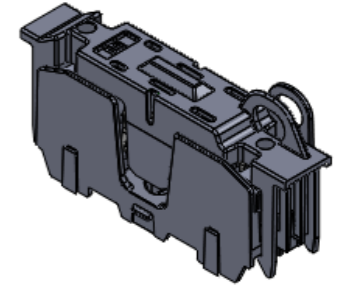

3D VIEW FOR HM25030-1xR  
WITH COVER  
SCALE NONE

**EATON** BUSSMANN SERIES

TITLE: 250V / 30AMP CLASS R & H FUSE BLOCK

SIZE: A3 DWG NO.: RM25030-HM25030-SERIES-CP REV: B

SCALE: 2:3 SHEET: 2 OF 3

勝特力材料 886-3-5753170  
 勝特力电子(上海) 86-21-34970699  
 勝特力电子(深圳) 86-755-83298787  
 Http://www.100y.com.tw

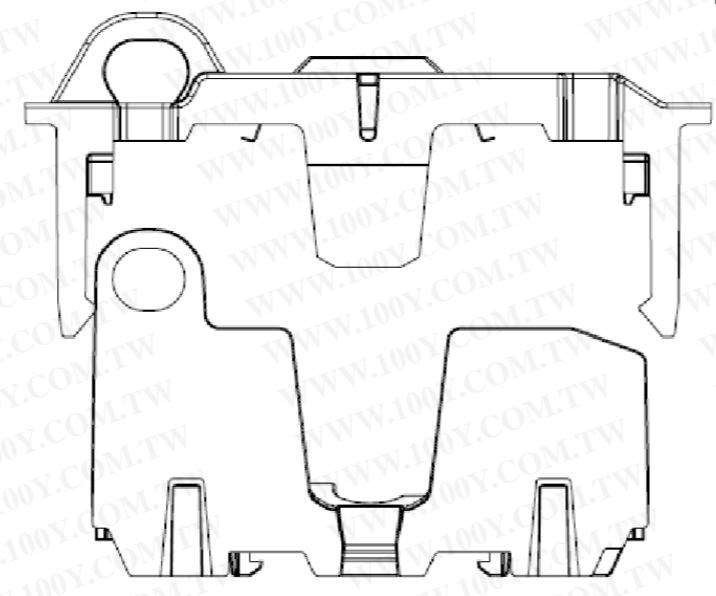
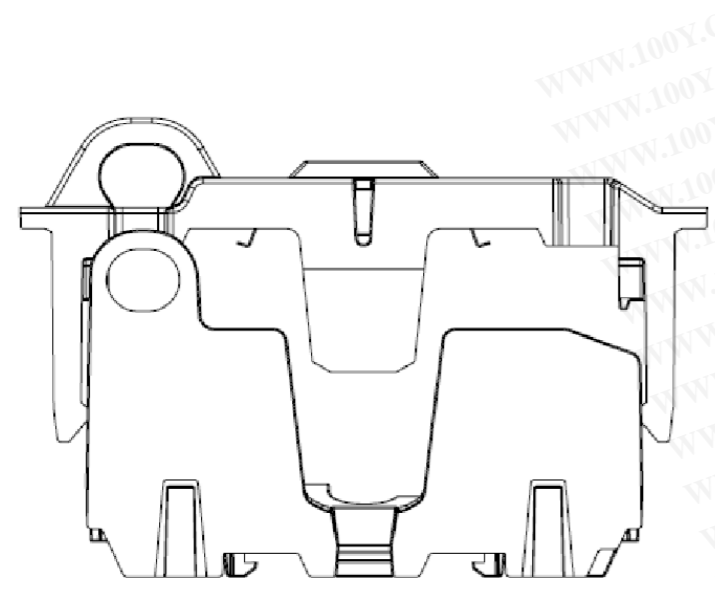

CUT COVER TAB AT NOTCH FOR WIRES LARGER THAN 8 AWG

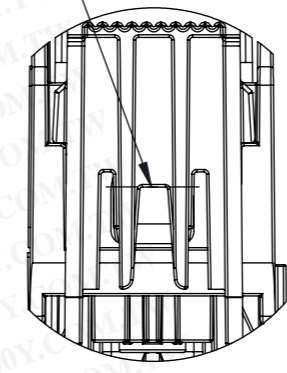

DETAIL A  
SCALE 4:3

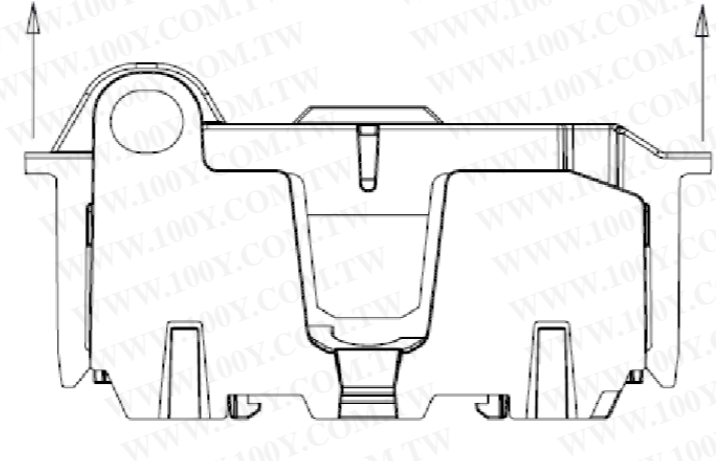
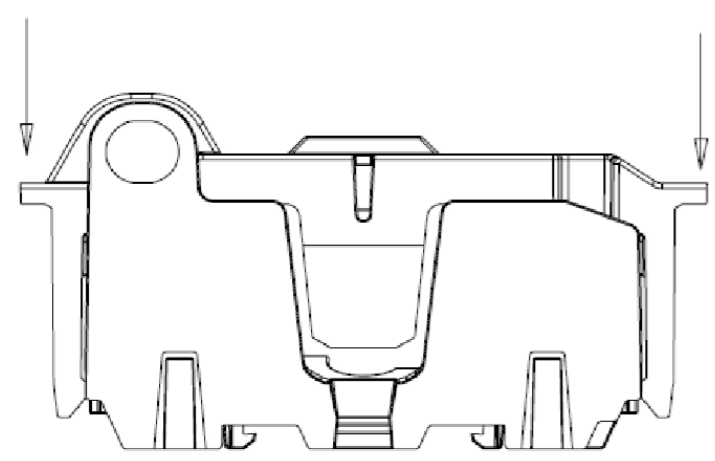

**CLOSING**  
PUSH STRAIGHT DOWN UNTIL SNAPS CLICK INTO PLACE

**OPENING**  
PULL STRAIGHT UP AT BOTH OUTSIDE HANDLES

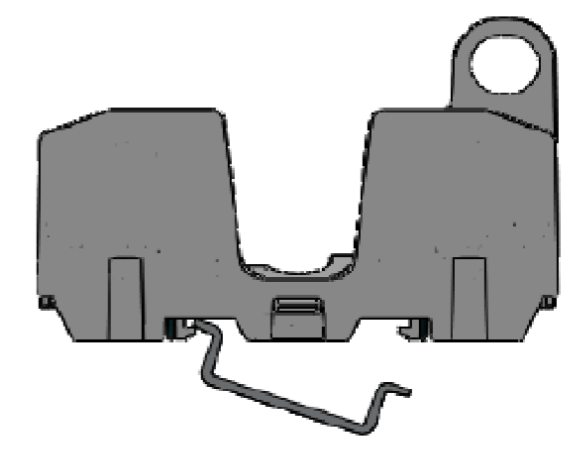

1. HOOK DIN RAIL SNAPS ON ONE SIDE OF THE DIN RAIL

2. PUSH DOWN TO DEFLECT THE SNAPS

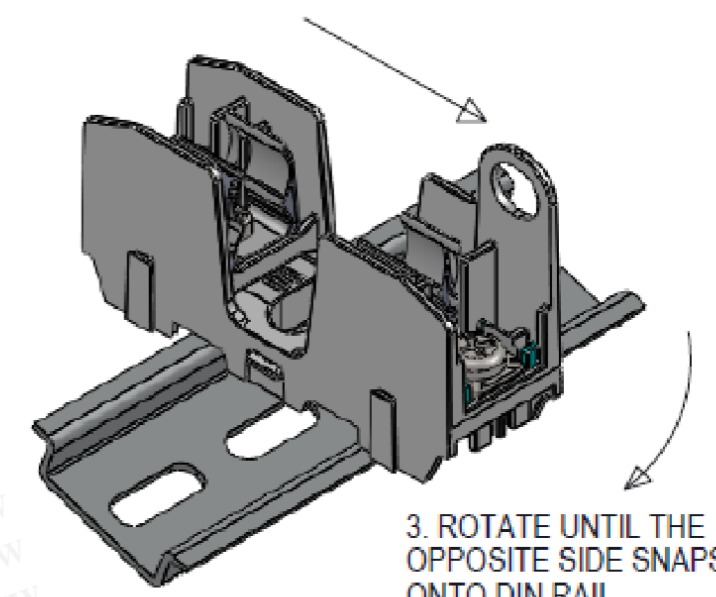

3. ROTATE UNTIL THE OPPOSITE SIDE SNAPS ONTO DIN RAIL

**INSTALLATION ON DIN RAIL**  
END STOPS MAY BE NECESSARY FOR SOME ASSEMBLY CONDITIONS - SEE NOTE 7



TITLE  
**250V / 30AMP CLASS R & H FUSE BLOCK**

SIZE <b>A3</b>	DWG NO. <b>RM25030-HM25030-SERIES-CP</b>	REV <b>B</b>
SCALE: 2:3	SHEET 3 OF 3	