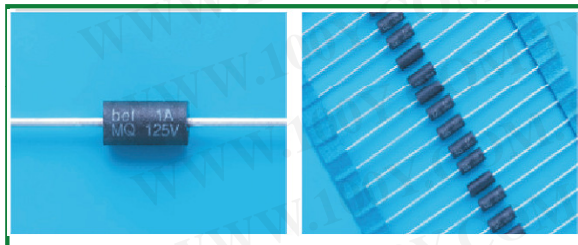

RoHS

bel

MQ May2012D

Type MQ
Quick Acting Micro Fuse3 X 7 mm Size
RoHS Compliant**HF** MQ Series Fuse**Features**

- Quick Acting
- Small size
- Wide range of current rating from 100mA to 15A
- Wide operating temperature range
- RoHS compliant
- Halogen Free

Applications**Electrical Characteristics (UL / CSA /STD.248-14)**

Testing Current	Blow Time	
	Minimum	Maximum
100%	4 Hrs.	N/A
200%	N/A	5 Sec

- Notebook
- LCD monitor
- PC computer
- Office electronic equipment
- Industrial equipment
- Medical equipment
- POE, POE+
- LCD / LED monitor
- Power supply
- LCD / LED TV

HALOGEN FREE = **HF****Safety Agency Approvals**

SAFETY AGENCY	SAFETY AGENCY CERTIFICATE	AMPERE RANGE / VOLT @ I.R.ABILITY
	LR39772	100mA - 15A / 125V @50A AC;300A DC
	E20624	

勝特力材料 886-3-5753170
 勝特力电子(上海) 86-21-34970699
 勝特力电子(深圳) 86-755-83298787
[Http://www.100y.com.tw](http://www.100y.com.tw)

Specifications Subject to change without notice.

Type MQ

Quick Acting Micro Fuse

3 X 7 mm Size
RoHS Compliant



bel

MQ May2012D

Electrical Specifications

Catalog Number	Ampere Rating	Typical Cold Resistance (ohm)	Volt-drop @100% In (volt) Max.	Voltage Rating (V)	Interrupting Rating	Melting I2T <10 m Sec (A2 Sec)	Melting I2T @ 10 In (A2 Sec)	Maximum Power Dissipation (W)	Certification		
									SP	UL	CE
MQ 100	100mA	13.8	2.70	125	100mA - 15A / 125V @50A AC;300A DC	0.0007	0.0006	0.35	Y	Y	Y
MQ 125	125mA	2.05	1.10	125		0.0012	0.0009	0.09	Y	Y	Y
MQ 150	150mA	1.56	1.00	125		0.0019	0.0015	0.10	Y	Y	Y
MQ 200	200mA	1.00	0.70	125		0.003	0.002	0.12	Y	Y	Y
MQ 250	250mA	0.52	0.45	125		0.005	0.004	0.14	Y	Y	Y
MQ 300	300mA	0.47	0.44	125		0.009	0.008	0.16	Y	Y	Y
MQ 375	375mA	0.41	0.43	125		0.013	0.012	0.18	Y	Y	Y
MQ 500	500mA	0.25	0.42	125		0.025	0.023	0.21	Y	Y	Y
MQ 750	750mA	0.152	0.41	125		0.062	0.056	0.27	Y	Y	Y
MQ 1	1 A	0.110	0.40	125		0.11	0.10	0.33	Y	Y	Y
MQ 1.5	1.5 A	0.064	0.28	125		0.29	0.25	0.42	Y	Y	Y
MQ 2	2 A	0.055	0.27	125		0.33	0.27	0.33	Y	Y	Y
MQ 2.5	2.5 A	0.038	0.26	125		0.59	0.50	0.40	Y	Y	Y
MQ 3	3 A	0.028	0.25	125		1.06	0.90	0.48	Y	Y	Y
MQ 3.5	3.5 A	0.027	0.24	125		1.4	1.2	0.53	Y	Y	Y
MQ 4	4 A	0.023	0.23	125		1.9	1.6	0.58	Y	Y	Y
MQ 5	5 A	0.017	0.22	125		3.4	3.0	0.71	Y	Y	Y
MQ 7	7 A	0.012	0.20	125		8	7	0.94	Y	Y	Y
MQ 10	10 A	0.006	0.11	125		25	21	1.30	Y	Y	Y
MQ 12	12 A	0.005	0.10	125		41	35	1.50	Y	Y	Y
MQ 15	15 A	0.004	0.10	125	70	63	1.80	Y	Y	Y	

Consult manufacturer for other ratings

勝特力材料 886-3-5753170
 胜特力电子(上海) 86-21-34970699
 胜特力电子(深圳) 86-755-83298787
[Http://www.100y.com.tw](http://www.100y.com.tw)

CORPORATE OFFICE

Bel Fuse Inc.
 206 Van Vorst Street
 Jersey City, NJ 07302
 Tel 201-432-0463
 Fax 201-432-9542
 E-Mail: belfuse@belf.com
 Website: www.belfuse.com

FAR EAST OFFICE

Bel Fuse Ltd.
 8/F Luk Hop Industrial Building
 8 Luk Hop Street
 San Po Kong
 Kowloon, Hong Kong
 Tel 852-2328-5515
 Fax 852-2352-3706

EUROPE OFFICE

Bel Fuse Europe Ltd.
 Preston Technology Management Centre
 Marsh Lane, Suite F15
 Preston, Lancashire, PR1 8UQ
 United Kingdom
 Tel 44-1772-556601
 Fax 44-1772-561008

EUROPE

Bel Stewart GmbH
 Industriestrasse 20
 61381 Friedrichsdorf
 Germany
 Tel 49-6172-9552-0
 Fax 49-6172-9552-40

Type MQ

Quick Acting Micro Fuse

RoHS Compliant



MQ May2012C

Temperature Derating Curve

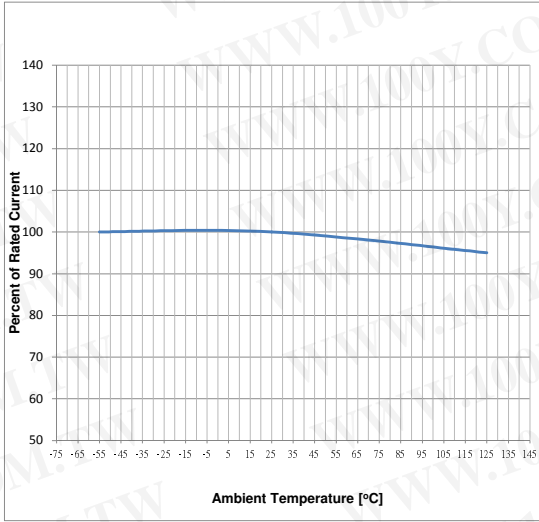

Average Time Current Curve

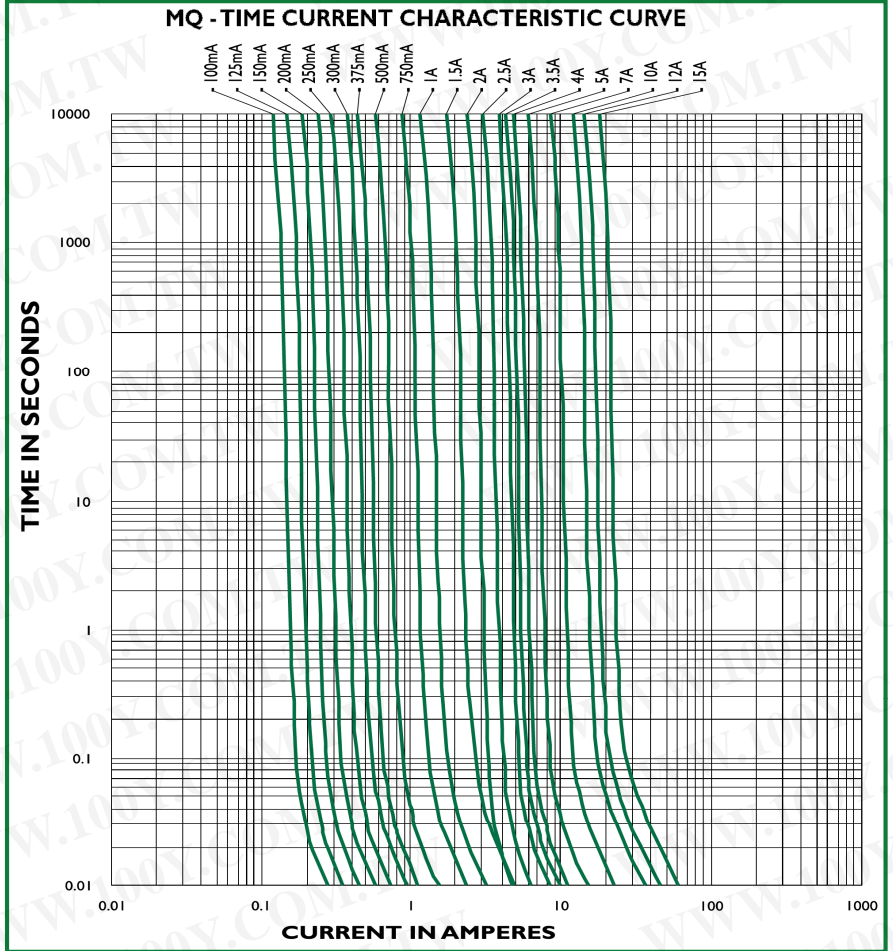

勝特力材料 886-3-5753170
 勝特力电子(上海) 86-21-34970699
 勝特力电子(深圳) 86-755-83298787
[Http://www.100y.com.tw](http://www.100y.com.tw)

Soldering Parameters

Wave Soldering Profile	
Wave Soldering Parameter	
Average ramp-up rate	200°C / second
Heating rate during preheat	typical 1 - 2°C / second Max. 4°C / second
Final preheat temperature	within 125°C of soldering temperature
Peak temperature T _p	260°C
Time within +0°C / -5°C of actual peak temperature	10 seconds
Ramp-down rate	5°C / second max.

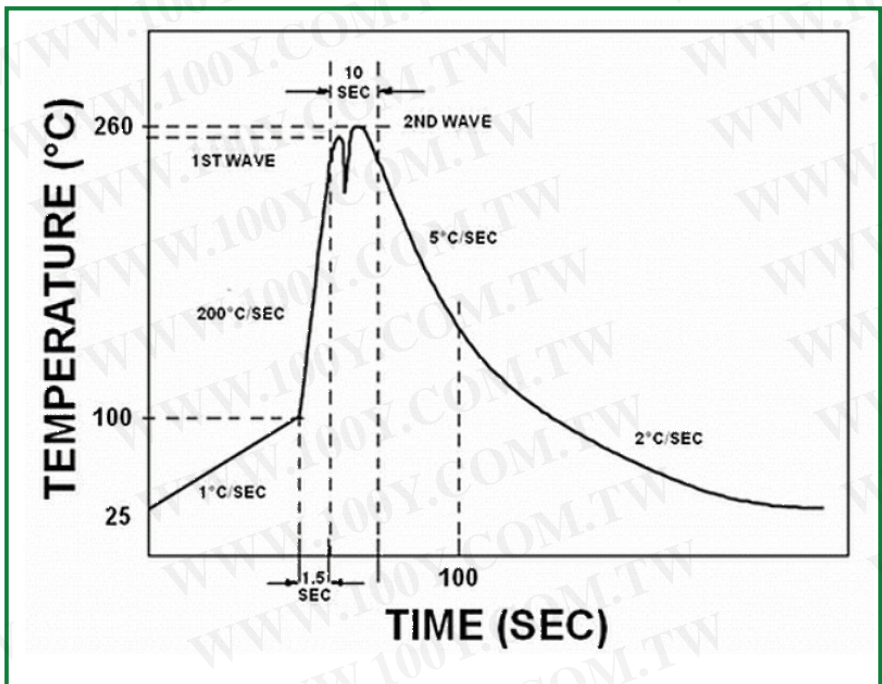

Type MQ



Quick Acting Micro Fuse

3 x 7 mm Size
RoHS Compliant



MQ May2012D

Physical Specifications

Materials	Body : Molded with UL Recognized epoxy component plastic,UL 94-V0
	Lead Wire: Matte tin plated copper
Marking	On Fuse:
	"bel", "MQ", "Current Rating", "125V" printed in white color
	On label:
	"bel" , "MQ", "Current Rating", "Voltage Rating", "Interrupting Rating", "Appropriate Safety Logos" and "  ",  "(China RoHS compliant).

Environmental Specifications

Shock Resistance	MIL-STD-202G, Method 213B, Test Condition I (100 G's peak for 6 milliseconds; Sawtooth Waveform)
Vibration Resistance	MIL-STD-202G, Method 201A (10-55 Hz, 0.06 inch, total excursion).
Salt Spray Resistance	MIL-STD-202G, Method 101E, Test condition B (48 hrs).
Insulation Resistance	MIL-STD-202G, Method 302, Test Condition A (After Opening) 10,000 ohms minimum.
Solderability	MIL-STD-202G, Method 208H
Resistance to Solder Heat	MIL-STD-202G Method 210F, Test Condition B, (260°C, 10 sec)
Thermal Shock	MIL-STD-202G, Method 107G, Test Condition B (-65°C to +125°C).
Operating Temperature	-55°C to +125°C
Moisture Resistance	MIL-STD-202F, Method 106G

勝特力材料 886-3-5753170
 勝特力电子(上海) 86-21-34970699
 勝特力电子(深圳) 86-755-83298787
[Http://www.100y.com.tw](http://www.100y.com.tw)

Mechanical Dimensions

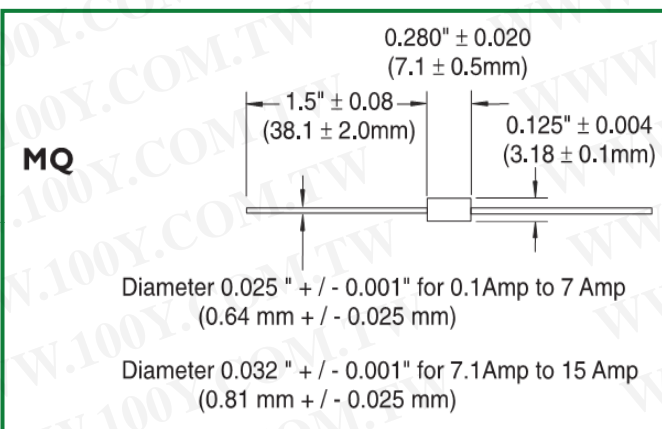

Ordering Information

FUSE TYPE	0674
AMPERE RATING	Refer to fuse FGNO explanation table
VOLTAGE CODE	0 = Standard specification (125V)
QUANTITY & PACKAGING CODE	1 = 250 pcs / Bulk bag, 1K / Box, Axial lead type 7 = 1000 pcs/bag/box, Ammo package 8 = 2500 pcs/ Reel, Tape and Reel

0674 - XXXX - X X

Packaging

Packaging Option	Packaging Specification	Quantity	Packaging Code	Inside Tape Spacing
Bulk	N/A	250	01	N/A
Bulk (Amon Package)	N/A	1000	07	N/A
Tape & Reel, 5 mm Pitch	EIA-296-F	2500	08	53

Specifications Subject to change without notice.

CORPORATE OFFICE

Bel Fuse Inc.
 206 Van Vorst Street
 Jersey City, NJ 07302
 Tel 201-432-0463
 Fax 201-432-9542
 E-Mail: belfuse@belf.com
 Website: www. belfuse.com

FAR EAST OFFICE

Bel Fuse Ltd.
 8/F Luk Hop Industrial Building
 8 Luk Hop Street
 San Po Kong
 Kowloon, Hong Kong
 Tel 852-2328-5515
 Fax 852-2352-3706

EUROPE OFFICE

Bel Fuse Europe Ltd.
 Preston Technology Management Centre
 Marsh Lane, Suite F15
 Preston, Lancashire, PR1 8UQ
 United Kingdom
 Tel 44-1772-556601
 Fax 44-1772-561008

EUROPE

Bel Stewart GmbH
 Industriestrasse 20
 61381 Friedrichsdorf
 Germany
 Tel 49-6172-9552-0
 Fax 49-6172-9552-40