



## Features

- Compliant with AEC-Q200 Rev-C- Stress Test Qualification for Passive Components in Automotive Applications
- Operating temperature range up to 125 °C
- Low thermal derating factor
- Higher hold currents at elevated temperature
- Choice of operating currents
- RoHS compliant\* and Pb free
- Resettable fault protection of general electronic equipment

## MF-RHT Series - PTC Resettable Fuses

### Electrical Characteristics

| Model      | V max. Volts | I max. Amps | I <sub>hold</sub> | I <sub>trip</sub> | Resistance        |                                | Max. Time To Trip |                  | Tripped Power Dissipation |
|------------|--------------|-------------|-------------------|-------------------|-------------------|--------------------------------|-------------------|------------------|---------------------------|
|            |              |             | Amperes at 23 °C  |                   | Ohms at 23 °C     |                                | Amperes at 23 °C  | Seconds at 23 °C | Watts at 23 °C            |
|            |              |             | Hold              | Trip              | R <sub>Min.</sub> | R <sub>1Max.</sub> (Post Trip) |                   | Max.             | Typ.                      |
| MF-RHT070  | 16           | 40          | 0.7               | 1.4               | 0.3               | 0.8                            | 3.5               | 4.0              | 1.4                       |
| MF-RHT200  | 16           | 100         | 2.0               | 3.8               | 0.045             | 0.110                          | 12.5              | 3.0              | 1.4                       |
| MF-RHT450  | 16           | 100         | 4.5               | 7.8               | 0.022             | 0.054                          | 22.5              | 3.0              | 3.6                       |
| MF-RHT650  | 16           | 100         | 6.5               | 12.0              | 0.011             | 0.026                          | 32.5              | 5.5              | 4.3                       |
| MF-RHT750  | 16           | 100         | 7.5               | 13.1              | 0.0094            | 0.022                          | 37.5              | 7.0              | 4.5                       |
| MF-RHT1300 | 16           | 100         | 13.0              | 24.0              | 0.0041            | 0.010                          | 60.0              | 13.0             | 6.9                       |

### Environmental Characteristics

|                            |                                                                   |
|----------------------------|-------------------------------------------------------------------|
| Operating Temperature..... | -40 °C to +125 °C                                                 |
| Storage Temperature.....   | -40 °C to +85 °C                                                  |
| Passive Aging.....         | +85 °C, 1000 hours..... ±15 % typical resistance change           |
| Humidity Aging.....        | +85 °C, 85 % R.H. 1000 hours..... ±15 % typical resistance change |
| Thermal Shock.....         | MIL-STD-202, Method 107..... ±10 % typical resistance change      |
|                            | +125 °C to -40 °C, 10 cycles                                      |
| Vibration.....             | MIL-STD-883C, Method 2007.1, Condition A..... No change           |

### Test Procedures And Requirements For Model MF-RHT Series

| Test                 | Test Conditions                                       | Accept/Reject Criteria                   |
|----------------------|-------------------------------------------------------|------------------------------------------|
| Visual/Mech.....     | Verify dimensions and materials.....                  | Per MF physical description              |
| Resistance.....      | In still air @ 23 °C.....                             | R <sub>min</sub> ≤ R ≤ R <sub>1max</sub> |
| Time to Trip.....    | At specified current, V <sub>max</sub> , 23 °C.....   | T ≤ max. time to trip (seconds)          |
| Hold Current.....    | 30 min. at I <sub>hold</sub> .....                    | No trip                                  |
| Trip Cycle Life..... | V <sub>max</sub> , I <sub>max</sub> , 100 cycles..... | No arcing or burning                     |
| Trip Endurance.....  | V <sub>max</sub> , 48 hours.....                      | No arcing or burning                     |
| Solderability.....   | MIL-STD-202, Method 208.....                          | 95 % min. coverage                       |

### Thermal Derating Chart - I<sub>hold</sub> (Amps)

| Model      | Ambient Operating Temperature |        |      |       |       |       |       |       |       |        |
|------------|-------------------------------|--------|------|-------|-------|-------|-------|-------|-------|--------|
|            | -40 °C                        | -20 °C | 0 °C | 23 °C | 40 °C | 50 °C | 60 °C | 70 °C | 85 °C | 125 °C |
| MF-RHT070  | 0.95                          | 0.87   | 0.79 | 0.7   | 0.62  | 0.56  | 0.51  | 0.47  | 0.39  | 0.17   |
| MF-RHT200  | 2.71                          | 2.49   | 2.26 | 2.00  | 1.77  | 1.60  | 1.46  | 1.34  | 1.11  | 0.49   |
| MF-RHT450  | 6.1                           | 5.6    | 5.1  | 4.5   | 4.0   | 3.6   | 3.3   | 3.0   | 2.5   | 1.1    |
| MF-RHT650  | 8.8                           | 8.1    | 7.4  | 6.5   | 5.7   | 5.3   | 4.8   | 4.3   | 3.6   | 1.6    |
| MF-RHT750  | 10.2                          | 9.4    | 8.6  | 7.5   | 6.6   | 6.1   | 5.6   | 5.0   | 4.1   | 1.9    |
| MF-RHT1300 | 17.7                          | 16.3   | 14.8 | 13.0  | 11.4  | 10.5  | 9.6   | 8.6   | 7.2   | 3.3    |

### How to Order

**MF - RHT 750 -**

Multifuse® Product Designator \_\_\_\_\_

Series \_\_\_\_\_

RHT = High Temperature Radial Leaded Component

Hold Current, I<sub>hold</sub> \_\_\_\_\_

070 - 1300 (0.70 - 13.00 Amps)

Packaging Options \_\_\_\_\_

- = Bulk Packaging

- 2 = Tape and Reel\*

- AP = Ammo-Pak\*

\*Packaged per EIA 486-B

勝特力材料 886-3-5753170  
 勝特力电子(上海) 86-21-34970699  
 勝特力电子(深圳) 86-755-83298787  
[Http://www.100y.com.tw](http://www.100y.com.tw)

\*RoHS Directive 2002/95/EC Jan 27 2003 including Annex.

Specifications are subject to change without notice.

Customers should verify actual device performance in their specific applications.

## Applications

- Protection of automotive circuitry including engine control modules
- Overcurrent surge protection of electronic equipment required to operate at high operating temperature ranges
- Resettable fault protection of general electronic equipment

## MF-RHT Series - PTC Resettable Fuses

**BOURNS®**

### Product Dimensions

| Model      | A               |                 | B               |                | C             |               | D               |       | E        |  | F |  | Physical Characteristics |  |
|------------|-----------------|-----------------|-----------------|----------------|---------------|---------------|-----------------|-------|----------|--|---|--|--------------------------|--|
|            | Max.            | Max.            | Nom.            | Tol. ±         | Min.          | Max.          | Nom.            | Style | Material |  |   |  |                          |  |
| MF-RHT070  | 6.86<br>(0.27)  | 10.8<br>(0.425) | 5.1<br>(0.201)  | 0.7<br>(0.028) | 7.6<br>(0.30) | 3.0<br>(0.12) | 0.51<br>(0.020) | 1     | Sn/CuFe  |  |   |  |                          |  |
| MF-RHT200  | 9.4<br>(0.37)   | 14.0<br>(0.55)  | 5.1<br>(0.201)  | 0.7<br>(0.028) | 7.6<br>(0.30) | 3.0<br>(0.12) | 0.51<br>(0.020) | 3     | Sn/Cu    |  |   |  |                          |  |
| MF-RHT450  | 10.4<br>(0.41)  | 15.6<br>(0.61)  | 5.1<br>(0.201)  | 0.7<br>(0.028) | 7.6<br>(0.30) | 3.0<br>(0.12) | 0.81<br>(0.032) | 2     | Sn/Cu    |  |   |  |                          |  |
| MF-RHT650  | 12.7<br>(0.50)  | 22.2<br>(0.88)  | 5.1<br>(0.201)  | 0.7<br>(0.028) | 7.6<br>(0.30) | 3.0<br>(0.12) | 0.81<br>(0.032) | 2     | Sn/Cu    |  |   |  |                          |  |
| MF-RHT750  | 14.0<br>(0.55)  | 23.5<br>(0.93)  | 5.1<br>(0.201)  | 0.7<br>(0.028) | 7.6<br>(0.30) | 3.0<br>(0.12) | 0.81<br>(0.032) | 2     | Sn/Cu    |  |   |  |                          |  |
| MF-RHT1300 | 23.5<br>(0.925) | 28.7<br>(1.17)  | 10.2<br>(0.402) | 0.7<br>(0.028) | 7.6<br>(0.30) | 3.6<br>(0.14) | 1.0<br>(0.040)  | 2     | Sn/Cu    |  |   |  |                          |  |

Packaging:

BULK: 500 pcs. per bag

TAPE & REEL: MF-RHT070 ~ MF-RHT200 = 3000 pcs. per reel; MF-RHT450 ~ MF-RHT650 = 1500 pcs. per reel;  
MF-RHT750 ~ MF-RHT1300 = 1000 pcs. per reel

AMMO-PACK: MF-RHT070 ~ MF-RHT200 = 2000 pcs. per pack; MF-RHT450 ~ MF-RHT750 = 1000 pcs. per pack;  
MF-RHT1300 = 500 pcs. per pack

0.51 (24AWG)  
0.81 (20AWG)  
1.0 (18AWG)

DIMENSIONS:  $\frac{\text{MM}}{\text{(INCHES)}}$

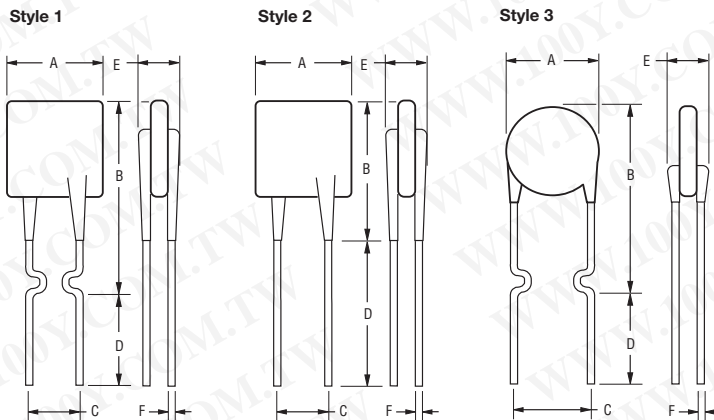

### Typical Part Marking

Represents total content. Layout may vary.

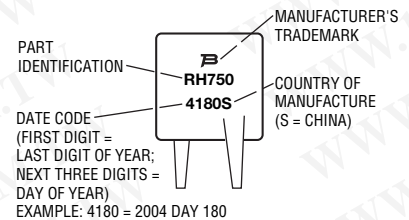

### Typical Time to Trip at 23 °C

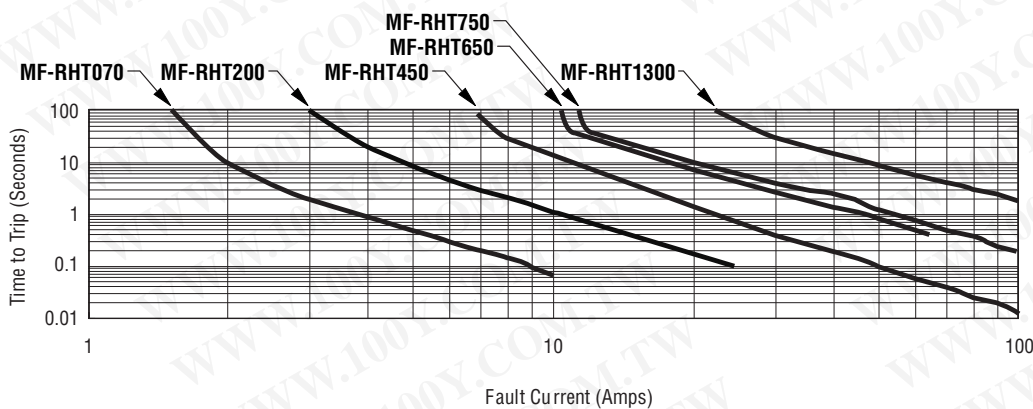

The Time to Trip curves represent typical performance of a device in a simulated application environment. Actual performance in specific customer applications may differ from these values due to the influence of other variables.

MF-RHT SERIES, REV. E, 01/10

Specifications are subject to change without notice.

Customers should verify actual device performance in their specific applications.

# MF-RHT Series Tape and Reel Specifications

**BOURNS®**

Devices taped using EIA468-B/IEC60286-2 standards. See table below and Figures 1 and 2 for details.

| Dimension Description                                     | IEC Mark   | EIA Mark   | Dimensions             |                                    |
|-----------------------------------------------------------|------------|------------|------------------------|------------------------------------|
|                                                           |            |            | Dimensions             | Tolerance                          |
| Carrier tape width                                        | $W$        | $W$        | $\frac{18}{(.709)}$    | $\frac{-0.5/+1.0}{(-0.02/+0.039)}$ |
| Hold down tape width                                      | $W_0$      | $W_4$      | $\frac{11}{(.433)}$    | min.                               |
| Hold down tape                                            |            |            | No protrusion          |                                    |
| Top distance between tape edges                           | $W_2$      | $W_6$      | $\frac{3}{(.118)}$     | max.                               |
| Sprocket hole position                                    | $W_1$      | $W_5$      | $\frac{9}{(.354)}$     | $\frac{-0.5/+0.75}{(-0.02/+0.03)}$ |
| Sprocket hole diameter                                    | $D_0$      | $D_0$      | $\frac{4}{(.157)}$     | $\frac{\pm 0.2}{(\pm .0078)}$      |
| Abscissa to plane (straight lead)                         | $H$        | $H$        | $\frac{18.5}{(.728)}$  | $\frac{\pm 3.0}{(\pm .118)}$       |
| Abscissa to plane (kinked lead)                           | $H_0$      | $H_0$      | $\frac{16}{(.63)}$     | $\frac{\pm 0.5}{(\pm .02)}$        |
| Abscissa to top: MF-RHT070 ~ MF-RHT450                    | $H_1$      | $H_1$      | $\frac{32.2}{(1.268)}$ | max.                               |
| Abscissa to top: MF-RHT650 ~ MF-RHT1300                   | $H_1$      | $H_1$      | $\frac{45.0}{(1.837)}$ | max.                               |
| Overall width w/lead protrusion: MF-RHT070 ~ MF-RHT450    |            | $C_1$      | $\frac{42.5}{(1.673)}$ | max.                               |
| Overall width w/lead protrusion: MF-RHT650 ~ MF-RHT1300   |            | $C_1$      | $\frac{55.0}{(2.165)}$ | max.                               |
| Overall width w/o lead protrusion: MF-RHT070 ~ MF-RHT450  |            | $C_2$      | $\frac{42.5}{(1.673)}$ | max.                               |
| Overall width w/o lead protrusion: MF-RHT650 ~ MF-RHT1300 |            | $C_2$      | $\frac{54.0}{(2.126)}$ | max.                               |
| Lead protrusion                                           | $l_1$      | $L_1$      | $\frac{1.0}{(.039)}$   | max.                               |
| Protrusion of cutout                                      | $L$        | $L$        | $\frac{11}{(.433)}$    | max.                               |
| Protrusion beyond hold-down tape                          | $l_2$      | $l_2$      | Not specified          |                                    |
| Sprocket hole pitch                                       | $P_0$      | $P_0$      | $\frac{12.7}{(0.5)}$   | $\frac{\pm 0.3}{(\pm .012)}$       |
| Pitch tolerance                                           |            |            | 20 consecutive         | $\frac{\pm 1}{(\pm .039)}$         |
| Device pitch: MF-RHT070 ~ MF-RHT450                       |            |            | $\frac{12.7}{(0.5)}$   | $\frac{\pm 0.3}{(\pm .012)}$       |
| Device pitch: MF-RHT650 ~ MF-RHT1300                      |            |            | $\frac{25.4}{(1.0)}$   | $\frac{\pm 0.6}{(\pm .024)}$       |
| Tape thickness                                            | $t$        | $t$        | $\frac{0.9}{(.035)}$   | max.                               |
| Tape thickness with splice: MF-RHT070                     |            | $t_1$      | $\frac{1.5}{(.059)}$   | max.                               |
| Tape thickness with splice: MF-RHT450 ~ MF-RHT1300        |            | $t_1$      | $\frac{2.3}{(.091)}$   | max.                               |
| Splice sprocket hole alignment                            |            |            | $\frac{4.0}{(.157)}$   | $\frac{\pm 0.2}{(\pm .008)}$       |
| Body lateral deviation                                    | $\Delta_h$ | $\Delta_h$ | 0                      | $\frac{\pm 1}{(\pm .039)}$         |
| Body tape plane deviation                                 | $\Delta_p$ | $\Delta_p$ | 0                      | $\frac{\pm 0.3}{(\pm .012)}$       |
| Ordinate to adjacent component lead                       | $P_1$      | $P_1$      | $\frac{3.81}{(.015)}$  | $\frac{\pm 0.07}{(\pm .028)}$      |

Specifications are subject to change without notice.  
Customers should verify actual device performance in their specific applications

DIMENSIONS:  $\frac{\text{MM}}{\text{(INCHES)}}$

# MF-RHT Series Tape and Reel Specifications

**BOURNS®**

| Dimension Description               | IEC Mark       | EIA Mark       | Dimensions              |                                           |
|-------------------------------------|----------------|----------------|-------------------------|-------------------------------------------|
|                                     |                |                | Dimensions              | Tolerance                                 |
| Lead spacing: MF-RHT070 ~ MF-RHT750 | F              | F              | $\frac{5.08}{(0.2)}$    | $\frac{-0.2/+0.8}{(-0.006/+0.031)}$       |
| Lead spacing: MF-RHT1300            | F              | F              | $\frac{10.2}{(0.402)}$  | $\frac{-0.2/+0.8}{(-0.006/+0.031)}$       |
| Reel width: MF-RHT070 ~ MF-RHT450   | w              | W <sub>2</sub> | $\frac{56}{(2.20)}$     | max.                                      |
| Reel width: MF-RHT650 ~ MF-RHT1300  | w              | W <sub>2</sub> | $\frac{63.5}{(2.50)}$   | max.                                      |
| Reel diameter                       | d              | a              | $\frac{370.0}{(14.57)}$ | max.                                      |
| Space between flanges less device   | W <sub>1</sub> | h              | $\frac{4.75}{(0.187)}$  | $\frac{\pm 3.25}{(\pm 0.128)}$            |
| Arbor hole diameter                 | f              | c              | $\frac{26.0}{(1.02)}$   | $\frac{\pm 12.0}{(\pm 0.472)}$            |
| Core diameter                       | h              | n              | $\frac{80.0}{(3.15)}$   | max.                                      |
| Box                                 |                |                | $\frac{64}{(2.52)}$     | $\frac{372}{(14.6)}$ $\frac{372}{(14.6)}$ |
| Consecutive missing places          |                |                | 3                       | max.                                      |
| Empty places per reel               |                |                | Not specified           |                                           |

**Taped Component Dimensions - Figure 1**

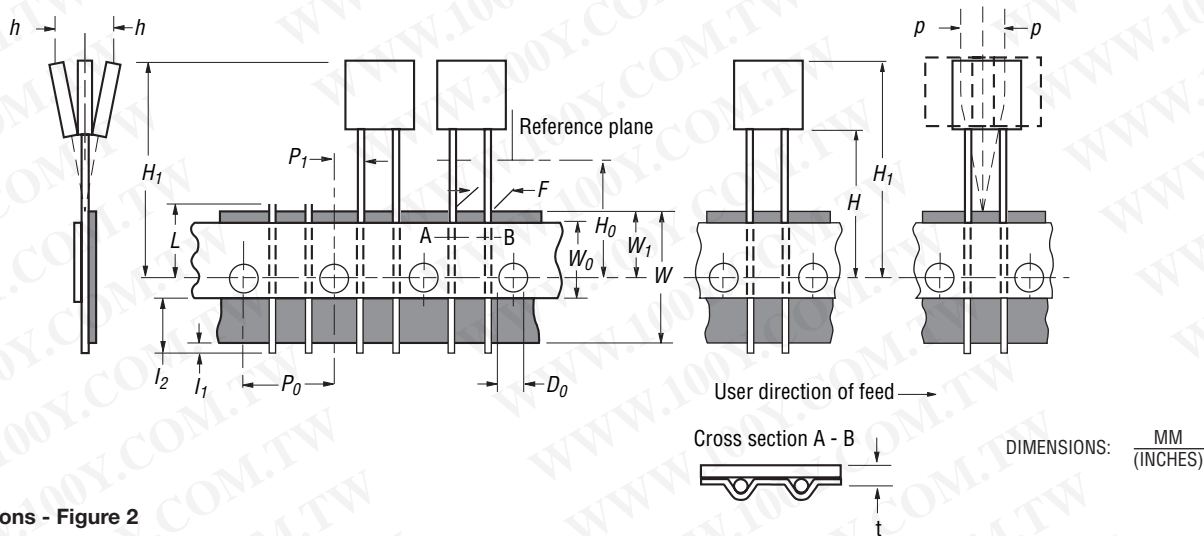

**Reel Dimensions - Figure 2**

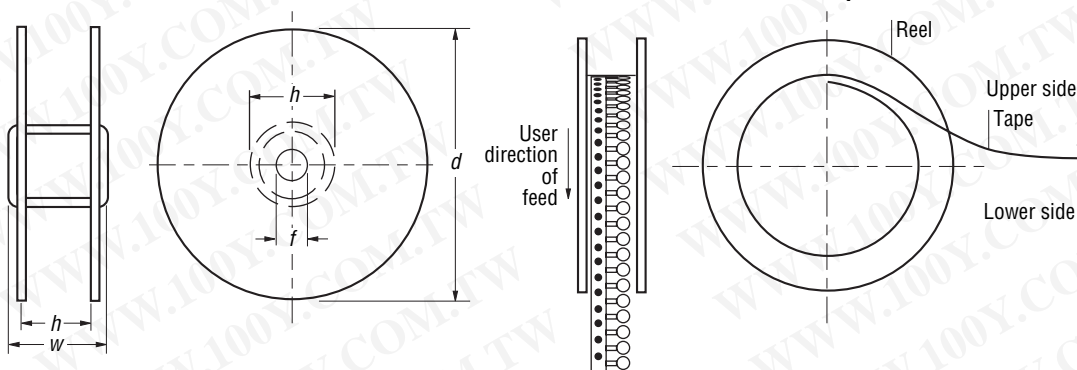

Specifications are subject to change without notice. Customers should verify actual device performance in their specific applications