

SUNON®

勝特力材料 886-3-5753170
勝特力电子(上海) 86-21-34970699
勝特力电子(深圳) 86-755-83298787
[Http://www.100y.com.tw](http://www.100y.com.tw)

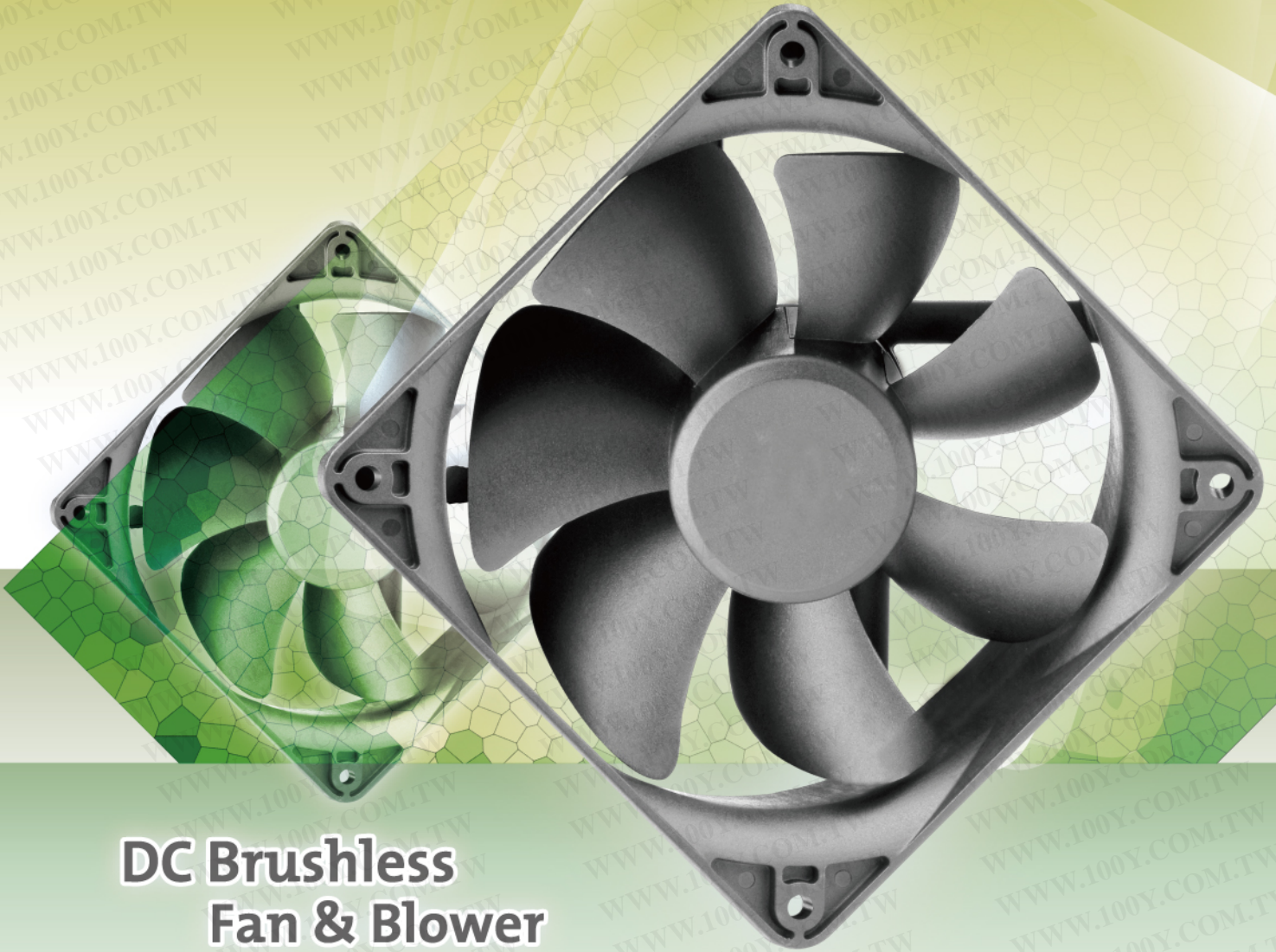

DC Brushless Fan & Blower

*All products are RoHS compliant.

DR MagLev®



		Page
Sunon DR-MagLev (English)		P. 02
Sunon Research Center		P. 03
Sunon Sound Quality		P. 04
Sunon Total Thermal Solution		P. 05
Sunon Production Network		P. 06
New DC Fan & Blower Model Numbering System / Certification & Safety		P. 07
DC Fan		
Size (mm)	Air Flow (CFM)	Page
17x17x8	0.7~0.9	P. 08
20x20x8	1.3~1.6	P. 09
20x20x10	1.5~1.9	P. 10
25x25x6	2.2~3.0	P. 11
25x25x10	3.0~3.5	P. 12
25x25x15	2.2~3.1	P. 13
30x30x6	3.7~4.9	P. 14
30x30x10	4.6~5.5	P. 15
30x30x15	4.8~6.0	P. 16
35x35x10	6.5~7.0	P. 17
38x38x28	18.1~23.0	P. 18
40x40x10	7.0~9.9	P. 19
40x40x20	6.3~10.8	P. 20
40x40x28	24.9~31.3	P. 21
40x40x56	26.9~31.7	P. 22
45x45x10	9.2~11.0	P. 23
50x50x10	11.0~13.8	P. 24
50x50x15	10.2~17.0	P. 25
50x50x15	12.9~18.6	P. 26
60x60x10	11.7~16.0	P. 27
60x60x15	18.0~21.0	P. 28
60x60x15	18.1~25.2	P. 29
60x60x20	16.0~30.5	P. 30
60x60x20	16.5~25.5	P. 31
60x60x25	29.0~40.0	P. 32
60x60x25	16.0~27.0	P. 33
60x60x25	13.9~23.5	P. 34
70x70x10	14.5~20.5	P. 35
70x70x20	43.0~37.0	P. 36
70x70x20	23.5~29.0	P. 37
80x80x15	30.0~37.0	P. 38
80x80x20	53.0~45.0	P. 39
80x80x20	29.0~36.0	P. 40
80x80x25	53.0~60.0	P. 41
80x80x25	33.0~45.0	P. 42
80x80x32	50.3~59.4	P. 43
92x92x25	65.0~75.0	P. 44
92x92x25	39.5~55.0	P. 45
120x120x25	75.0~108.2	P. 46
120x120x38	93.0~138.0	P. 47

DR MagLev Motor Fan

[DR MagLev = Dust-Resistance MagLev]

Advantages

Sunon DR Maglev (Dust-Resistance MagLev) Motor Fan uses the MagLev technology with new design features of dust-resistance and S&C (seal & clip).

After 8 years of development and testing, Sunon's DR MagLev Motor Fan is being introduced with five advantages: prevents the stator and impeller from moving, better oil leak prevention, better dust-resistance, higher reliability, and longer life expectancy.

Design Concepts and Characteristics of DR MagLev

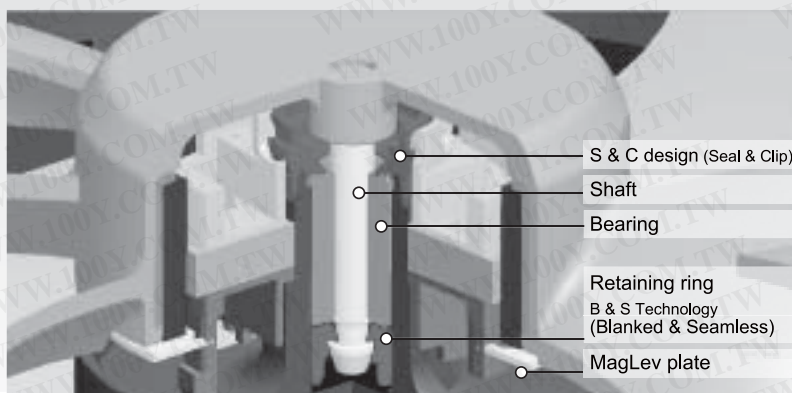

The two innovative design concepts of DR MagLev development are B&S (Blanked & Seamless) Technology and S&C (Seal & Clip) Design.

These innovative designs bring three excellent efficiencies to extend fan life:

1. To avoid dust invasion and extend motor life.
2. To prevent oil leakage.
3. To prevent the motor components from falling off.

(Note: The design concepts of DR MagLev Motor are suitable for every kind of motor and product size. The structures are different from the above picture, which was made when the DR MagLev design was applied to different motors.)

Characteristic 1

The innovative S&C Design provides the best resistance to dust invasion.

Characteristic 2

DR MagLev's one-piece structure with the B&S Technology and S&C Design provides the best prevention of oil leakage.

Characteristic 3

The S&C Design strengthens the locked position of both motor and stator to avoid stator and impeller from moving due to temperature changes. This allows the product to be more stable and run longer.

SUNON Innovative S&C Design

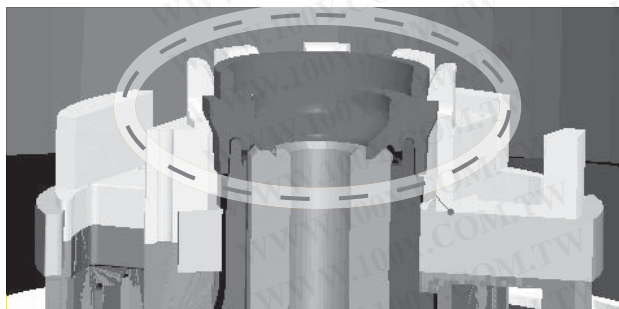

about Sunon

Sunon was founded in 1980 and has always upheld the philosophy of “Brand, Innovation, and Value” for their business operations. From the start, the Sunon name has become an international trademark that is well recognized and featured on products sold worldwide. Over the years, Sunon has continuously focused on developing and making innovations for their core motor technology, leading the industry in product trends for motors, cooling fans, and cooling modules. Sunon is one of the few operations in the world with a motor R&D team and is fully capable of developing innovative new motor designs. Examples for the R&D efforts are the world’s first MagLev design and Sunon Mighty Mini series, featuring a compact sub-centimeter size that is the world’s smallest and thinnest fan. Today, Sunon is the worldwide leader in precision motors and micro miniature fans, and is widely recognized by the industry as the designated partner for various multinational corporations. Sunon products are widely used in various applications and industries such as information technology, network communications, optoelectronics, and automobile electronics industries, as well as in industrial production equipment, medical equipment, home applications, OA machines, and others.

Sunon Research Center the Driving Engine for Inventions and Innovations

Sunon established the “Sunon Research Center” in Kaohsiung in 2002 to promote and execute the innovation blueprint for Sunon Group. Research labs and engineers from Europe, America, Japan, and China are centralized to form a worldwide technological service network for quick and efficient services.

Key Modules for Innovating Core Motor Technology

Sunon has been researching their motor technology for over 30 years and adhering to the Sunon R&D Trinity as their innovation roadmap, focusing on the three major technology fields of “Motor Research,” “Motor Applied Research,” and “Total Thermal Solution.” Sunon strives to expand the endless possibilities and optimization of motor applications and will continue to make breakthroughs and product innovations. The efforts will push Sunon to the front of the technology curve and clients will be able to realize their future dream products with the three key Sunon products of motors, cooling fans, and cooling modules.

Sunon has the capacity to design and implement the complete magnetic, mechanical, and driving circuit of a motor to conform to client design specifications. With the efforts of the mechanism and electrical circuit engineering teams, Sunon recognizes the needs of their clients regarding cooling modules and can provide flexible designs for high performance and high quality cooling fans. Sunon utilizes advanced simulation systems and analysis projects that result in an even more accurate heat analysis and heat dissipation design for the system. Subsequently the most efficient total thermal solution can be provided to the client.

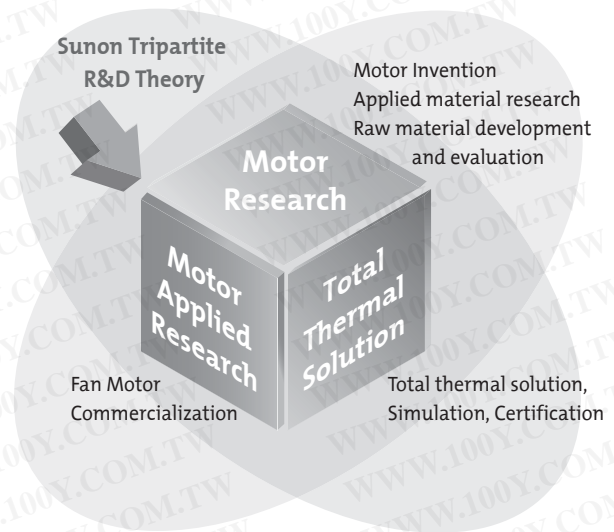

Sunon Sound Quality Analysis and Research

Sunon introduced acoustics engineering in the year 2000 to transform the traditional school of Sound Pressure and Sound Power into the more advanced theory of Sound Quality. Sunon's Sound Quality analysis and research is performed by Head Measurement System (HMS). The HMS system records and simulates the auditory senses of the human ears, where the sounds, vibration, rotation speed, and electrical signals are measured. The software subsequently performs time domain and sound quality parameter analysis to assist the acoustics engineers in allowing Sunon products to feature a more favorable sound quality. The expertise and experience of the acoustics engineer combined with the software analysis will result in an even more user-friendly environment that is rivaled by none.

Sound Quality Testing

Sound quality is measured in an semi anechoic chamber by means of Head Measurement System (HMS).

The Sound quality of fans can be described according to the objective parameter of sound (Loudness, Tonality, Roughness/Fluctuation, Sharpness).

After the recording of acoustic signals, the data is performed the FFT, order Psycho acoustic And modulation analyses and playback diagnosis in order to improve the sound quality of fans.

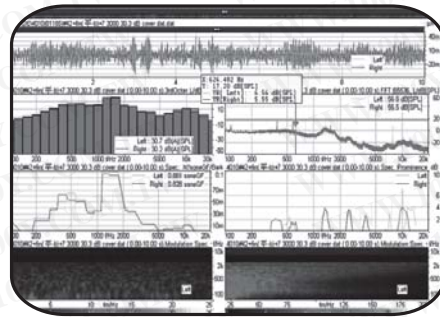
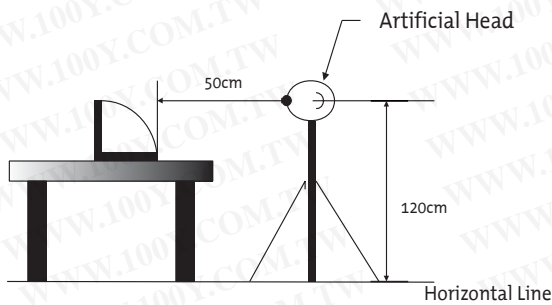

The mobile Sound Quality Laboratory SQlab II

SQlab II is a compact, mobile multi-channel measurement system for acoustic analysis, vibration investigation and sound design. It is used wherever investigation of sound quality should be combined with vibrational measurements.

The comparison of vibrational measurements with acoustic signals enables the user to draw direct conclusions from sound sources and their sound quality. For this purpose, SQlab II is able to measure aurally-accurate recordings of sound events using an Artificial Head and vibration data with accelerometers, etc. at the same time. Thus, correlations between the subjective aural impressions of sound events (airborne sound) and the related sources (vibration, solid-borne sound) as well as transfer mechanisms become apparent. This is the basis for sound optimization. Moreover, SQlab II can be used as a "stethoscope" for error analysis.

The Analysis Software

It can analyze, filter, display and document acoustic and vibration measurement data in a wide range of modes. Yet an outstanding feature of this software is the possibility of including the aural sense of the human user in signal analysis.

HEADphone Playback System

The digital 24 bit HEADphone Playback System HPS IV is complementary to the Head Measuring System HMS III. Conditioning of audio data for aurally-accurate playback is via equalization of the acoustic signal in the programmable Equalizer PEQ IV, with subsequent amplification via the Power Amplifier PVA IV.2. Two electrostatic headphones can be connected to the playback system, which are individually calibrated and correspondingly driven.

Sunon Total Thermal Solution

Sunon introduced its first chip cooling module in 1993, it has continued to rely on its impressive R&D team to also succeed in the laptop computer cooling module market. Sunon's innovative technology and superior design talent have consistently won customers' trust. In addition to Sunon's cutting-edge cooling fan products, it also offers laptop, VGA card, Desk Top, and server product designs. Sunon's cooling module product line ranges from low-end to high-end, enabling it the ability to provide customers with "Total Thermal Solutions."

Sophisticated Tools Strengthen Design and Quality

Apart from optimized design and superior R&D, we use infrared (IR) thermal imagers in module design work to make precise measurements of module temperatures, thereby avoiding the use of conventional thermocouples to measure temperatures. Our R&D personnel can instead rely on IR images to get a clear understanding of system temperature distribution. The data from our thermal imaging reports allow us to provide a clear system-wide thermal and cooling design analysis. In order to give customers the best quality guarantee, we go well beyond industry standards in production, assembly, inspection equipment design and deployment. We have also committed large amounts of manpower and material resources, and adopted the newest hardware and software equipment in our quest for quality. For instance, our thermal inspection systems can fully simulate thermal resistance measurements and pressure settings within systems and measure thermal resistance simultaneously at six different points. Precise measurements of pressure settings enable simulation of pressure within the system, making measurements even more accurate and protecting product quality by ensuring that excessive pressure doesn't cause product deformation. Furthermore, independent bar codes on each product ensure effective product tracking and improve the quality of after-sales service. We can satisfy our customers' needs for various types of customized cooling modules while meeting the highest quality requirements.

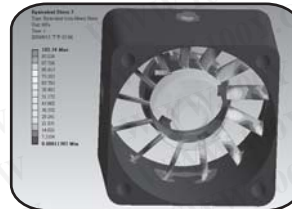

Structural Simulation analysis

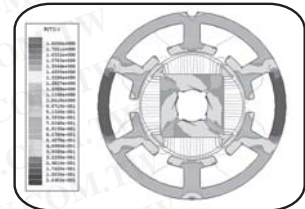

Magnetization Simulation analysis



Fluid dynamic analysis



3D model

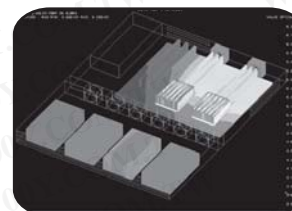

Thermal analysis

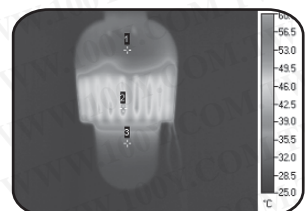

IR thermograph inspect

Advantage for Sunon Thermal Solutions Design

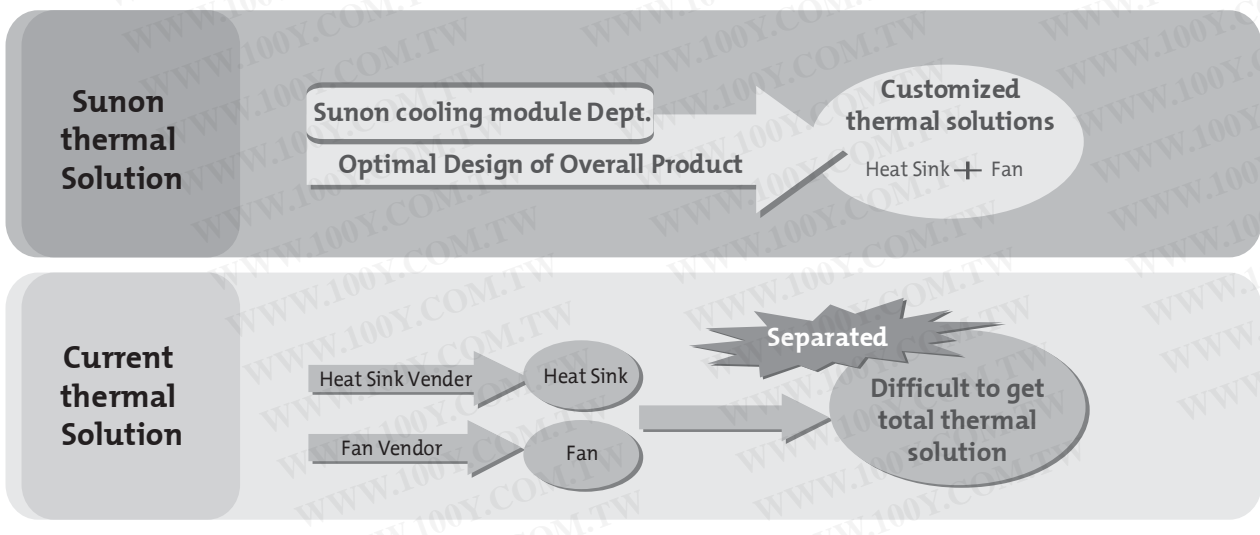

Sunon Reliability Verification System

Sunon has 5 reliability testing labs worldwide equipped with the topmost precision verification instruments for testing from the design phase, through pre-production, and into mass production. The complete verification system is computerized and fully automated for precise analysis of product reliability and quality satisfaction to meet the market requirements.

Sunon Production Network

Sunon Group has a total of four manufacturing plants located in both China and Taiwan for production of 8mm~250mm series of fan products, 0.1Watt~60Watt of motor products, and various cooling module products. The overall monthly production output capacity is 20 million units.

In addition to the MES system that provides clients with the best manufacturing quality, Sunon goes well beyond industry standards in production, assembly, inspection equipment design and deployment. Sunon has also committed large amounts of manpower and material resources, and adopted the newest hardware and software equipment, in our quest for quality. For example, an automated production line for cooling products, the self-developed automated inspection machine for the production line, a heat inspection system capable of six simultaneous measurements, and an independent barcode with each cooling product indicate Sunon's commitment.

Sunon manufacturing bases have obtained certifications for QS9000, ISO9001, ISO14001, ISO/TS16949, OHSAS18001 and IECQ QC080000. Each product has passed UL, TUV, VDE, CCC, CSA certifications and so on.

All Sunon products are RoHS compliant from design phase to mass production.

Sunon is the long-term green partner for SONY, CANON, SAMSUNG and various other multinational companies

Sunon deeply recognizes its corporate duty to protect our earth and the ecosystem and to reduce the use of materials that impact the environment. In light of this, Sunon has been actively promoting green product design, green purchasing, and green manufacturing reforms. All current product series conform to EU RoHS and China RoHS, and Sunon has been selected as the green environment partner for multinational corporations such as SONY, CANON, and SAMSUNG. All of the aforementioned efforts will result in greener products that have the least impact on the worldwide environment.

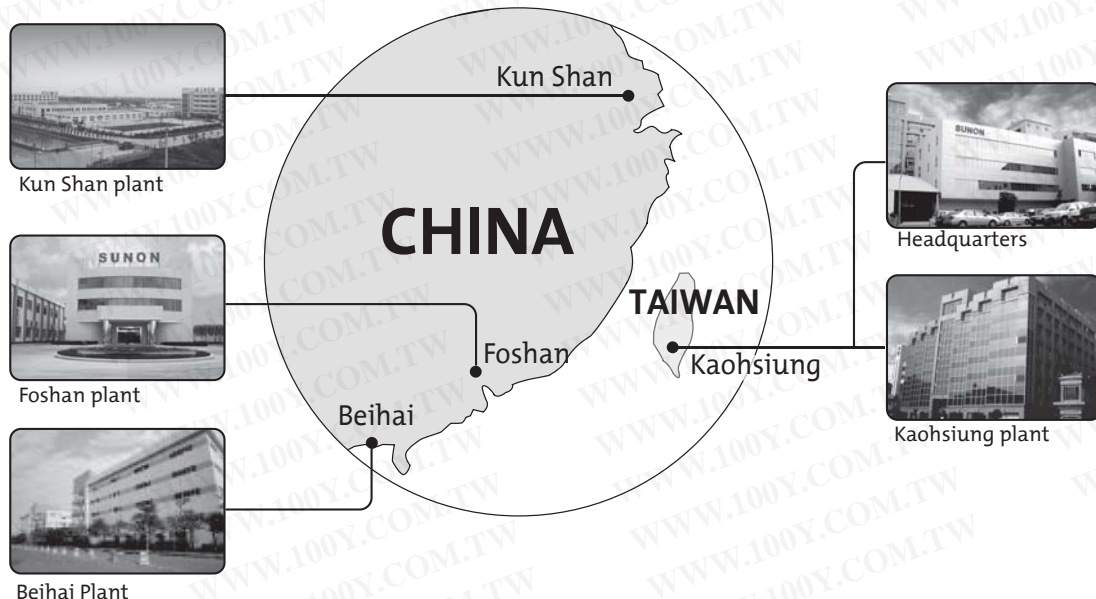

SUNON® New Model Numbering System

M E 80 25 1 V 1 — 0000 — A99

- Function Code
 999: standard model
 A99: AutoRestart
 C99: F type (3rd wire)
 D99: with PWM
 F99: AutoRestart and R type(3rd wire)
 G99: AutoRestart and F type(3rd wire)
 H99: AutoRestart and with PWM
 Q99: AutoRestart , R type and with PWM
 S99: AutoRestart , F type and with PWM
- Customer Code
 0000, 000C, 000U stand for standard model
- Speed
 X: Super High 3: Low
 1: High 4: Super Low
 2: Medium
- Bearing
 V: Vapo S: Sleeve
 B: 2 Ball
- Voltage
 0: 5VDC 3: 36VDC
 1: 12VDC 4: 48VDC
 2: 24VDC
- Fan Thickness
 0~9; A~Z (except O)
- Frame Size
 0~9; A~Z (except O)
- Motor Type
 Series Code
 E Series P Series
 M Series

Code	Size(mm)	Code	Size(mm)	Code	Size(mm)	Code	Size(mm)
01~09	01~09	A0~A9	100~109	K0~K9	200~209	V0~V9	300~309
10~19	10~19	B0~B9	110~119	L0~L9	210~219	W0~W9	310~319
20~29	20~29	C0~C9	120~129	M0~M9	220~229	X0~X9	320~329
30~39	30~39	D0~D9	130~139	N0~N9	230~239	Y0~Y9	330~339
40~49	40~49	E0~E9	140~149	P0~P9	240~249	Z0~Z9	340~349
50~59	50~59	F0~F9	150~159	Q0~Q9	250~259		
60~69	60~69	G0~G9	160~169	R0~R9	260~269		
70~79	70~79	H0~H9	170~179	S0~S9	270~279		
80~89	80~89	I0~I9	180~189	T0~T9	280~289		
90~99	90~99	J0~J0	190~199	U0~U9	290~299		

Certification



Safety

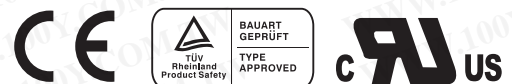

* Note: For critical or extreme environments, including non stop operation, please contact Sunon and we will gladly provide assistance with your product selection to ensure an appropriate cooling product for your application.
 * Note: The "Life Expectancy" of the fan has not been evaluated for use in combination with any end application. Therefore, the Life Expectancy Test Reports(L10 and MTF Report) that relate to the fan are only for reference.

17x17x8 mm

0.7~0.9 CFM

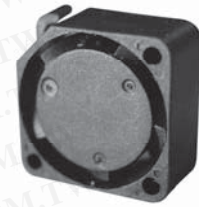

	P/N	Bearing	Rating Voltage (VDC)	Power Current (mA)	Power Consumption (WATTS)	Speed (RPM)	Air Flow (CFM)	Static Pressure (Inch-H ₂ O)	Noise (dBA)	Weight (g)	Curve
MC17080V1-0000-A99		●	5	160	0.80	20000	0.9	0.28	25.0	4.36	1
MC17080V2-0000-A99		●	5	100	0.50	15000	0.7	0.17	16.0	4.36	2

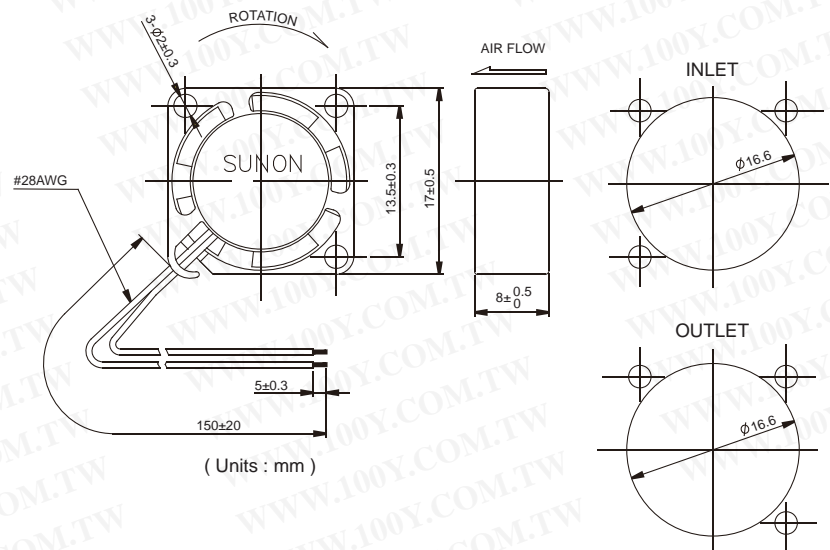
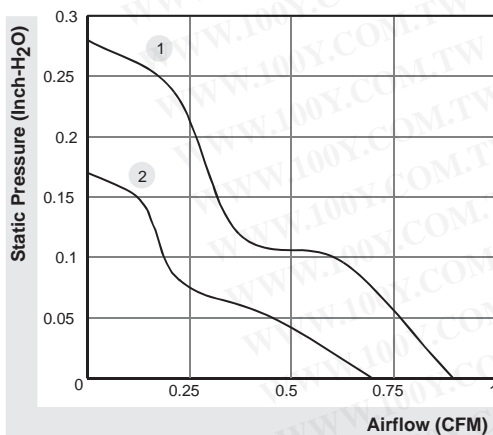



*All model could be customized. Please contact with Sunon Sales.

*Specifications are subject to change without notice. Please Visit SUNON web site at <http://www.sunon.com> for update information.

20x20x8 mm

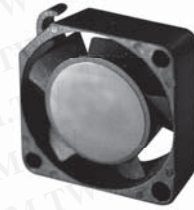
1.3~1.6 CFM



	P/N	Bearing	Rating Voltage (VDC)	Power Current (mA)	Power Consumption (WATTS)	Speed (RPM)	Air Flow (CFM)	Static Pressure (Inch-H ₂ O)	Noise (dBA)	Weight (g)	Curve
MC20080V1-0000-A99		●	5	135	0.68	15000	1.6	0.22	23.0	4.64	1
MC20080V2-0000-A99		●	5	90	0.45	12000	1.3	0.15	21.0	4.64	2

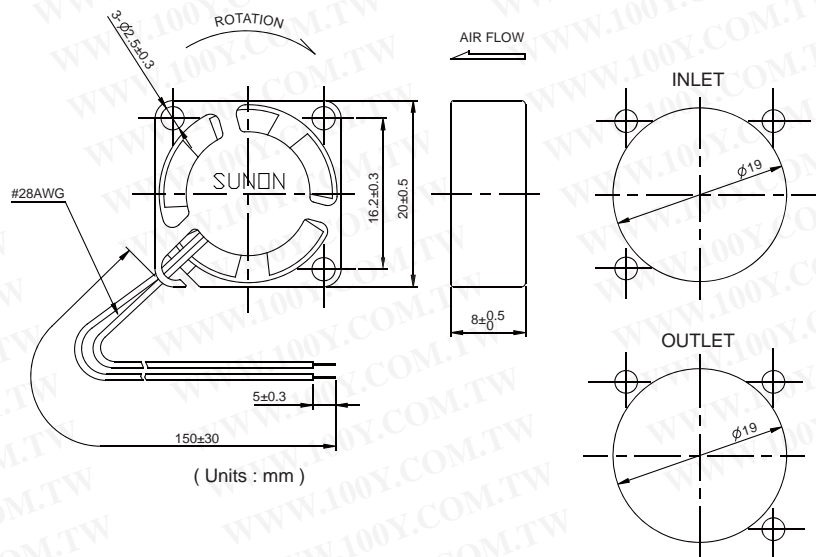
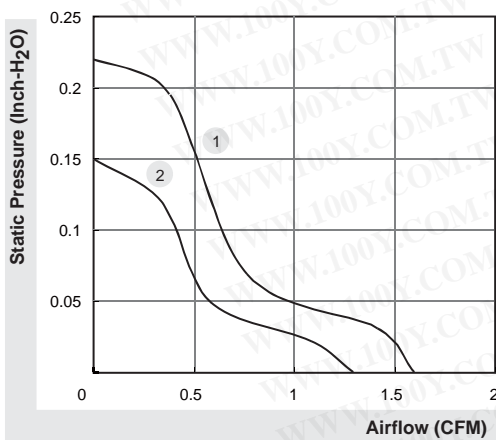



*All model could be customized. Please contact with Sunon Sales.

*Specifications are subject to change without notice. Please Visit SUNON web site at <http://www.sunon.com> for update information.

20x20x10 mm

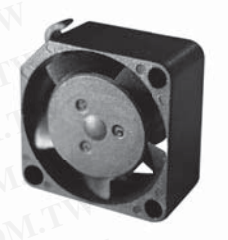
1.5~1.9 CFM



	P/N	Bearing	Rating Voltage (VDC)	Power Current (mA)	Power Consumption (WATTS)	Speed (RPM)	Air Flow (CFM)	Static Pressure (Inch-H ₂ O)	Noise (dBA)	Weight (g)	Curve
MC20100V1-0000-A99		●	5	210	1.05	17000	1.9	0.29	25.0	5.5	1
MC20100V2-0000-A99		●	5	155	0.78	14000	1.5	0.20	20.0	5.5	2

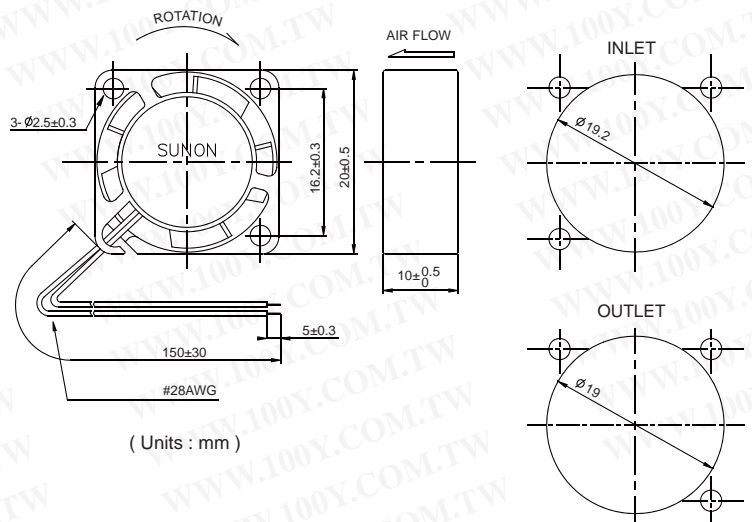
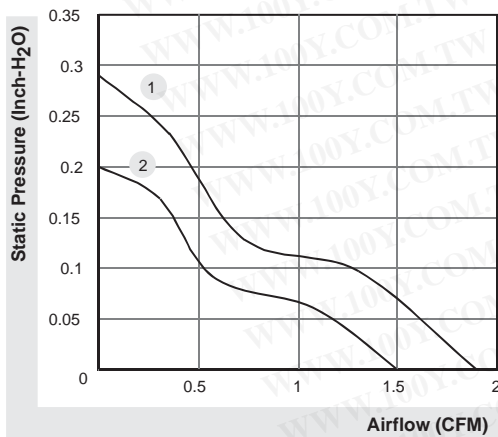

*All model could be customized. Please contact with Sunon Sales.

*Specifications are subject to change without notice. Please Visit SUNON web site at <http://www.sunon.com> for update information.

25x25x6 mm

2.2~3.0 CFM



	Bearing	Rating Voltage (VDC)	Power Current (mA)	Power Consumption (WATTS)	Speed (RPM)	Air Flow (CFM)	Static Pressure (Inch-H ₂ O)	Noise (dBA)	Weight (g)	Curve
	MC25060V1-0000-A99	● VAPO	5	115	0.58	13000	3.0	0.22	31.0	5.0
MC25060V2-0000-A99	●	5	75	0.38	10000	2.2	0.16	23.0	5.0	2

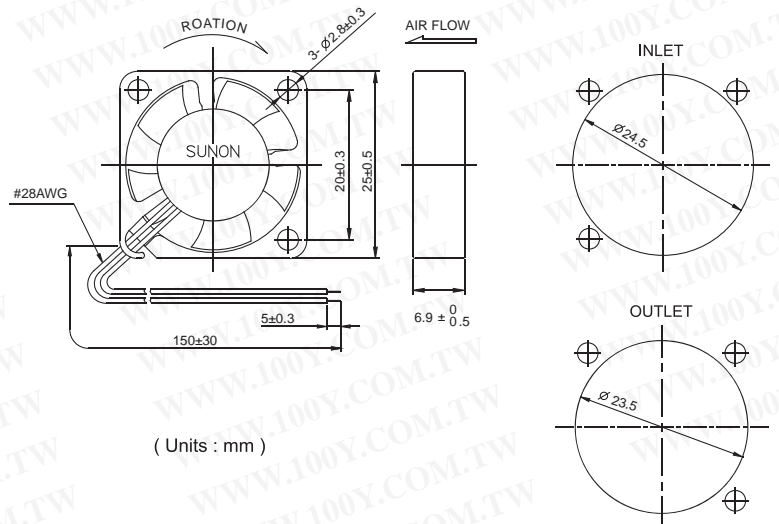
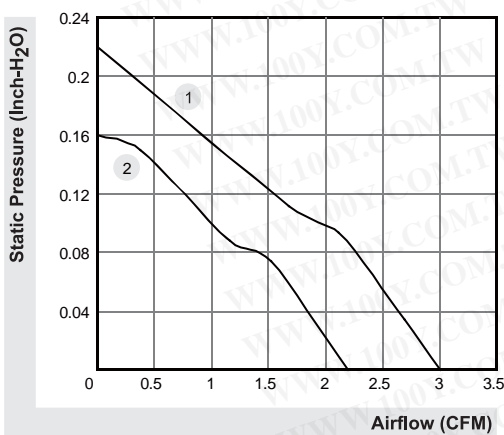



*All model could be customized. Please contact with Sunon Sales.

*Specifications are subject to change without notice. Please Visit SUNON web site at <http://www.sunon.com> for update information.

25x25x10 mm

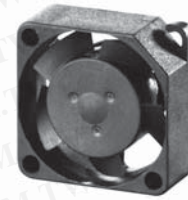
3.0~3.5 CFM



	Bearing	Rating Voltage (VDC)	Power Current (mA)	Power Consumption (WATTS)	Speed (RPM)	Air Flow (CFM)	Static Pressure (Inch-H ₂ O)	Noise (dBA)	Weight (g)	Curve
	● VAPO									
MC25100V1-0000-A99	●	5	120	0.60	13000	3.5	0.25	23.0	7.5	1
MC25100V2-0000-A99	●	5	85	0.43	10000	3.0	0.18	16.0	7.5	2
MC25101V1-0000-A99	●	12	57	0.69	13000	3.5	0.25	23.0	7.5	1
MC25101V2-0000-A99	●	12	37	0.45	10000	3.0	0.18	16.0	7.5	2

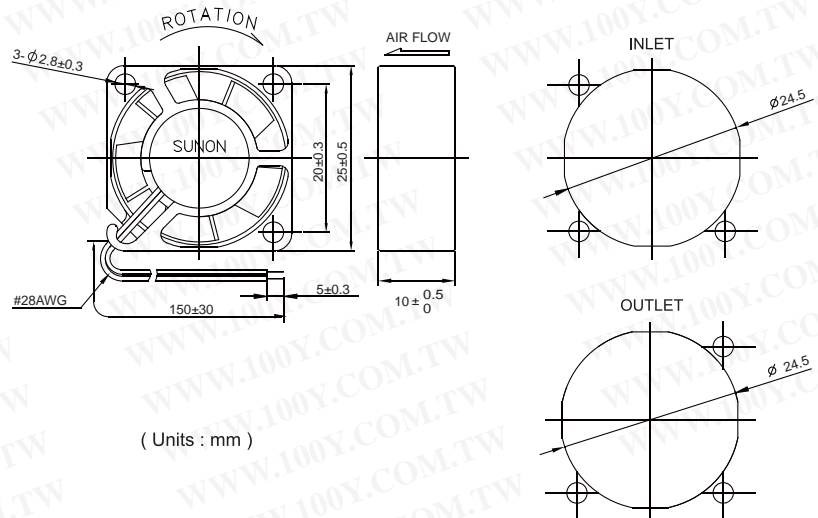
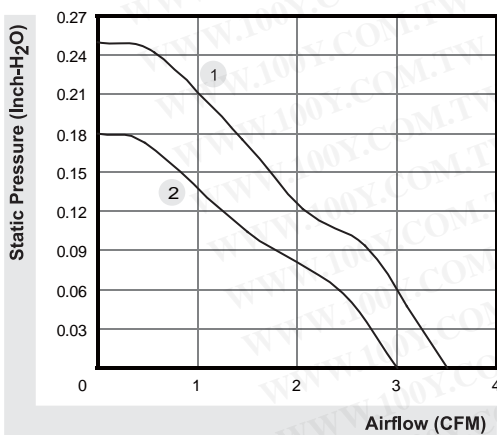

*All model could be customized. Please contact with Sunon Sales.

*Specifications are subject to change without notice. Please Visit SUNON web site at <http://www.sunon.com> for update information.

25x25x15 mm

2.2~3.1 CFM



	P/N	Bearing	Rating Voltage (VDC)	Power Current (mA)	Power Consumption (WATTS)	Speed (RPM)	Air Flow (CFM)	Static Pressure (Inch-H ₂ O)	Noise (dBA)	Weight (g)	Curve
MC25150V1-0000-A99		●	5	110	0.55	10000	3.1	0.16	20.0	11.0	1
MC25150V2-0000-A99		●	5	60	0.30	7000	2.2	0.11	14.0	11.0	2

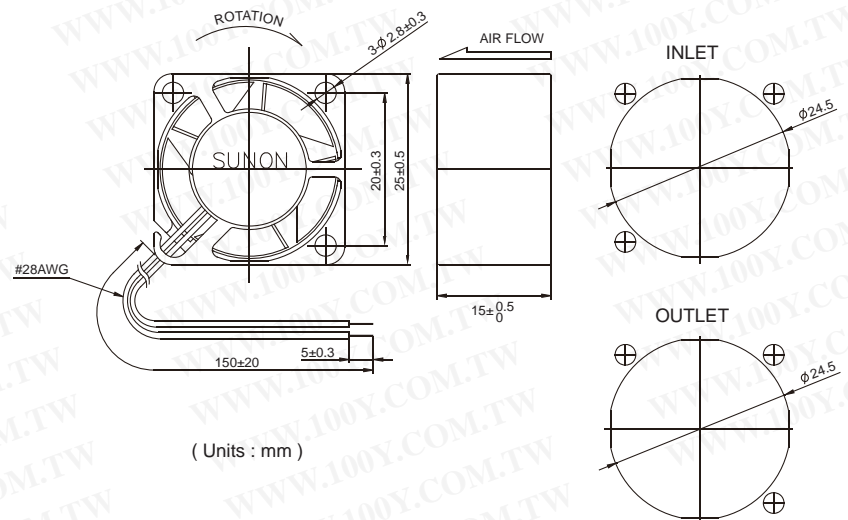
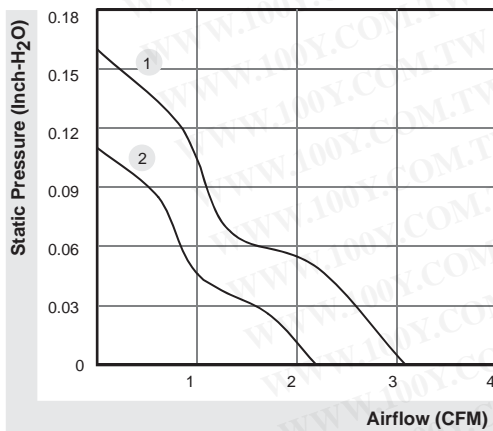

*All model could be customized. Please contact with Sunon Sales.

*Specifications are subject to change without notice. Please Visit SUNON web site at <http://www.sunon.com> for update information.

30x30x6 mm

3.7~4.9 CFM



	Bearing	Rating Voltage (VDC)	Power Current (mA)	Power Consumption (WATTS)	Speed (RPM)	Air Flow (CFM)	Static Pressure (Inch-H ₂ O)	Noise (dBA)	Weight (g)	Curve
	MC30060V1-0000-A99	● VAPO	5	112	0.56	9500	4.9	0.14	28.0	6.0
MC30060V2-0000-A99	●	5	72	0.36	7500	3.7	0.09	24.0	6.0	2

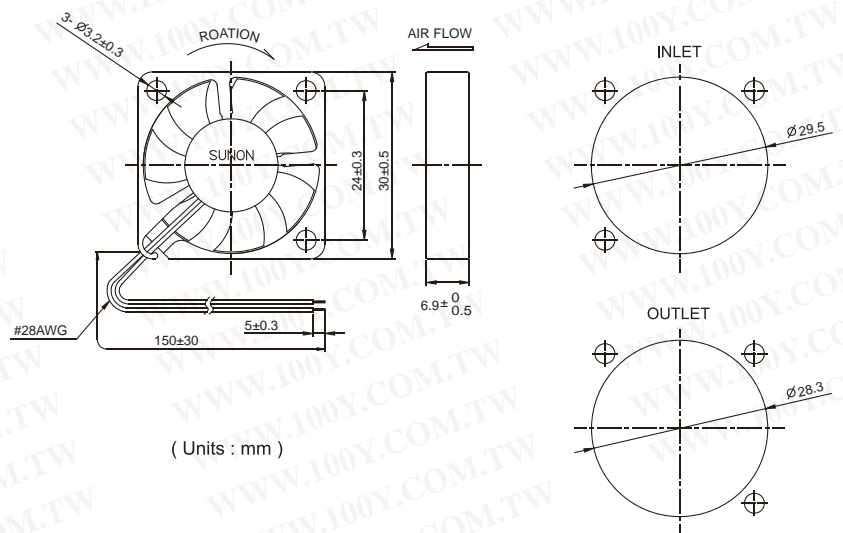
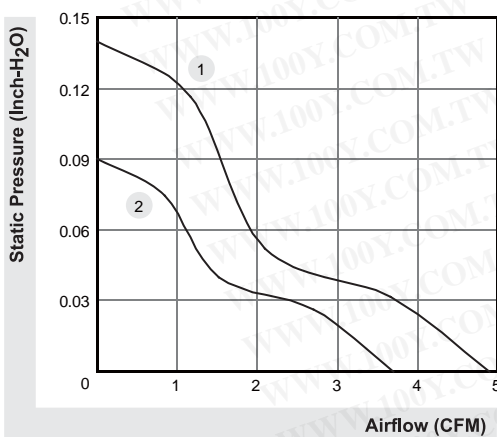

(Units : mm)

*All model could be customized. Please contact with Sunon Sales.

*Specifications are subject to change without notice. Please Visit SUNON web site at <http://www.sunon.com> for update information.

30x30x10 mm

4.6~5.5 CFM

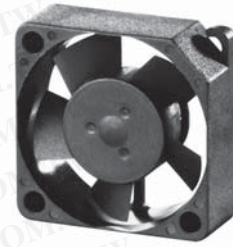

	Bearing	Rating Voltage (VDC)	Power Current (mA)	Power Consumption (WATTS)	Speed (RPM)	Air Flow (CFM)	Static Pressure (Inch-H ₂ O)	Noise (dBA)	Weight (g)	Curve
	● VAPO									
MC30100V1-0000-A99	●	5	120	0.60	9500	5.5	0.15	23.0	8.6	1
MC30100V2-0000-A99	●	5	75	0.38	8000	4.6	0.12	20.0	8.6	2
MC30101V1-0000-A99	●	12	48	0.58	9500	5.5	0.15	23.0	8.5	1
MC30101V2-0000-A99	●	12	40	0.48	8000	4.6	0.12	20.0	8.5	2

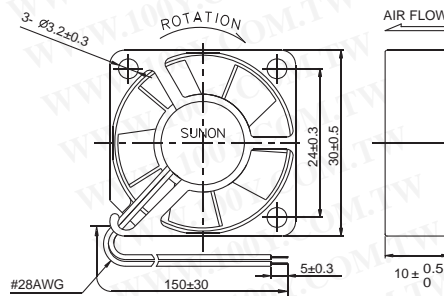
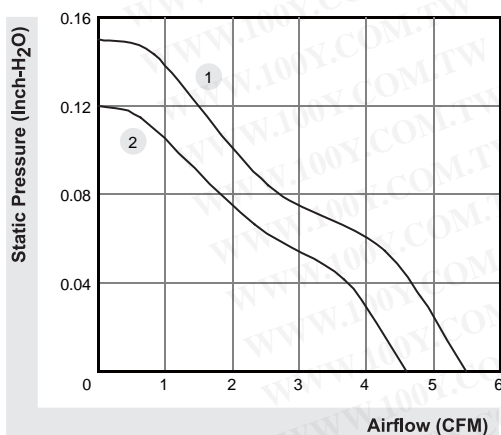

(Units : mm)

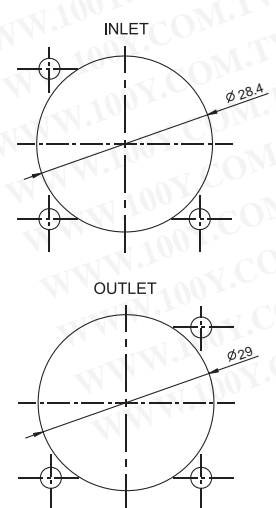



*All model could be customized. Please contact with Sunon Sales.

*Specifications are subject to change without notice. Please Visit SUNON web site at <http://www.sunon.com> for update information.

30x30x15 mm

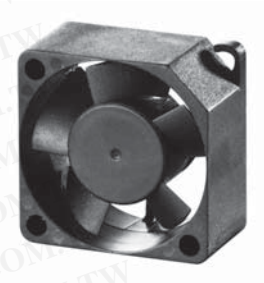
4.8~6.0 CFM



	Bearing	Rating Voltage (VDC)	Power Current (mA)	Power Consumption (WATTS)	Speed (RPM)	Air Flow (CFM)	Static Pressure (Inch-H ₂ O)	Noise (dBA)	Weight (g)	Curve
	● VAPO									
MC30150V1-0000-A99	●	5	114	0.57	8500	6.0	0.17	27.0	13.5	1
MC30150V2-0000-A99	●	5	75	0.37	7000	4.8	0.12	20.0	13.5	2
MC30151V1-0000-A99	●	12	54	0.65	8500	6.0	0.17	27.0	13.2	1
MC30151V2-0000-A99	●	12	37	0.45	7000	4.8	0.12	20.0	13.2	2

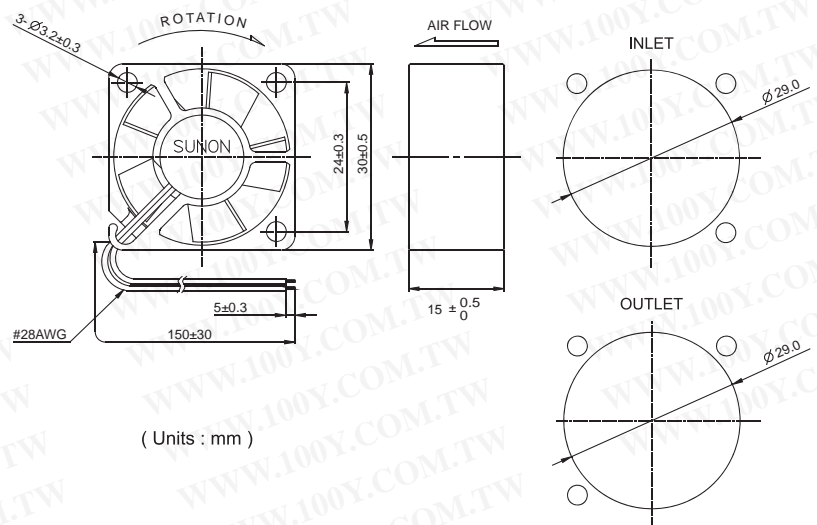
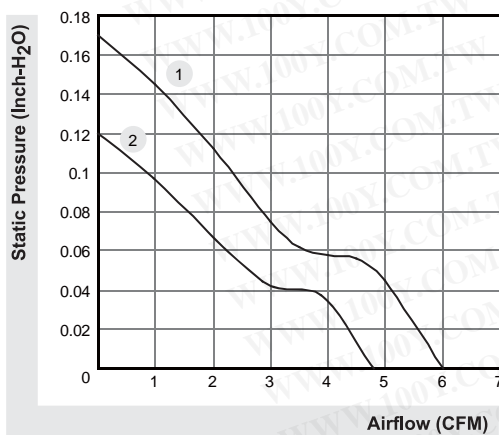



*All model could be customized. Please contact with Sunon Sales.

*Specifications are subject to change without notice. Please Visit SUNON web site at <http://www.sunon.com> for update information.

35x35x10 mm

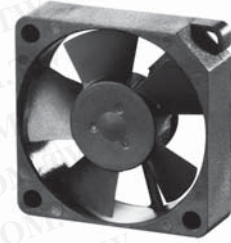
6.5~7.0 CFM



	Bearing	Rating Voltage (VDC)	Power Current (mA)	Power Consumption (WATTS)	Speed (RPM)	Air Flow (CFM)	Static Pressure (Inch-H ₂ O)	Noise (dBA)	Weight (g)	Curve
	● VAPO									
MC35100V1-0000-A99	●	5	150	0.75	9500	7.0	0.18	28.0	10.5	1
MC35100V2-0000-A99	●	5	75	0.38	7500	6.5	0.12	22.0	10.5	2
MC35101V1-0000-A99	●	12	60	0.72	9500	7.0	0.18	28.0	10.5	1
MC35101V2-0000-A99	●	12	43	0.52	7500	6.5	0.12	22.0	10.5	2

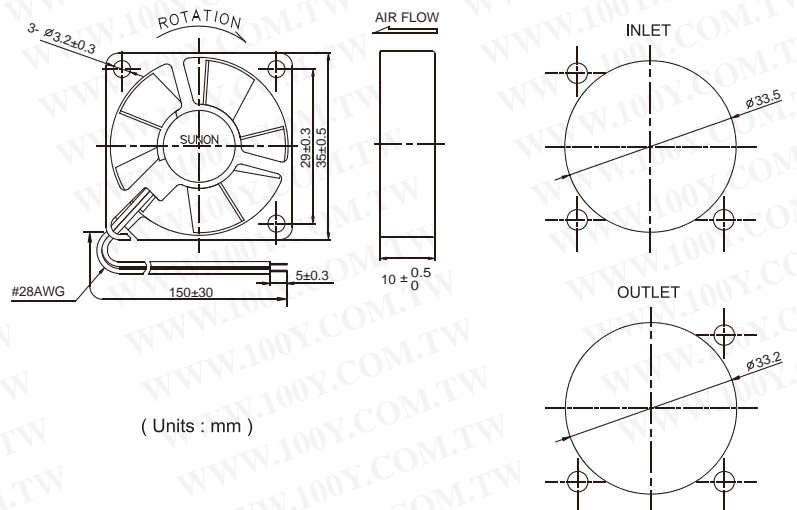
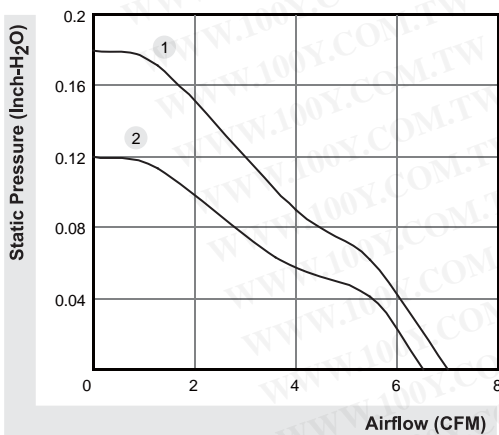

*All model could be customized. Please contact with Sunon Sales.

*Specifications are subject to change without notice. Please Visit SUNON web site at <http://www.sunon.com> for update information.

38x38x28 mm

18.1~23.0 CFM



Model	Bearing ⊙ 2BALL ○ Sleeve	Rating Voltage (VDC)	Power Current (mA)	Power Consumption (WATTS)	Speed (RPM)	Air Flow (CFM)	Static Pressure (Inch-H ₂ O)	Noise (dBA)	Weight (g)	Curve
PF38281BX-0000-A99	⊙	12	520	6.24	20000	23.0	2.23	59.0	41.0	1
PF38281B1-0000-A99	○	12	315	3.78	16000	18.1	1.42	53.8	41.0	2

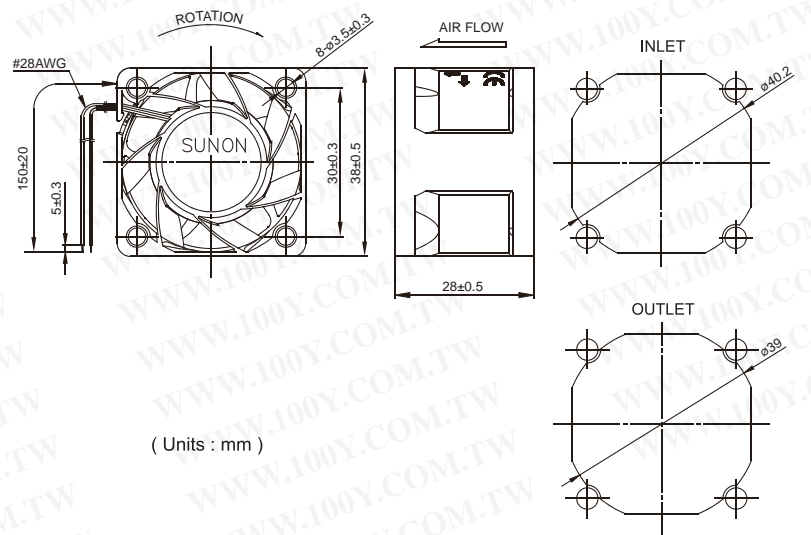
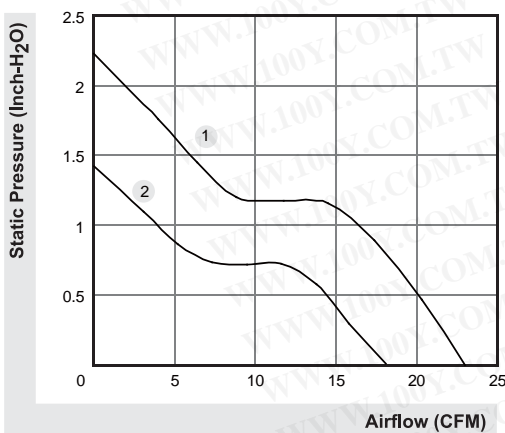

*All model could be customized. Please contact with Sunon Sales.

*Specifications are subject to change without notice. Please Visit SUNON web site at <http://www.sunon.com> for update information.

40x40x10 mm

7.0~9.9 CFM



Model	Bearing	Rating Voltage (VDC)	Power Current (mA)	Power Consumption (WATTS)	Speed (RPM)	Air Flow (CFM)	Static Pressure (Inch-H ₂ O)	Noise (dBA)	Weight (g)	Curve
ME40100V1-0000-A99	●	5	215	1.08	7000	8.0	0.19	32.0	13.5	2
MB40100V2-0000-A99	●	5	180	0.90	5800	7.0	0.11	27.0	17.0	3
ME40101VX-0000-A99	●	12	130	1.60	8500	9.9	0.24	36.1	15.0	1
ME40101V1-0000-A99	●	12	90	1.08	7000	8.0	0.19	32.0	13.5	2
MB40101V2-0000-A99	●	12	80	0.96	5800	7.0	0.11	27.0	17.0	3

Model	2BALL Sleeve	(VDC)	(mA)	(WATTS)	(RPM)	(CFM)	(Inch-H ₂ O)	(dBA)	(g)	Curve
EE40100S1-0000-999	○	5	215	1.18	7000	8.0	0.19	32.0	13.5	2
EB40100S2-0000-999	○	5	205	1.03	5800	7.0	0.11	27.0	17.0	3
EE40101S1-0000-999	○	12	100	1.20	7000	8.0	0.19	32.0	13.5	2
EB40101S2-0000-999	○	12	90	1.08	5800	7.0	0.11	27.0	17.0	3

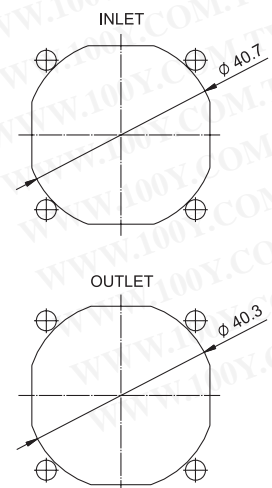
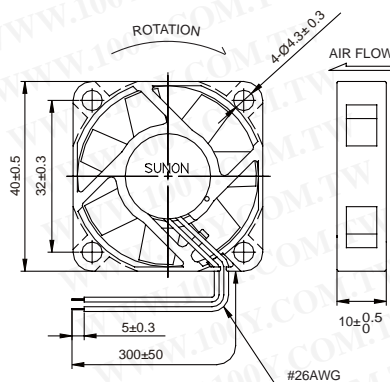
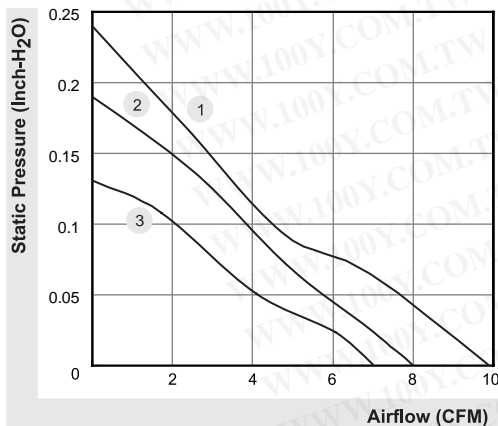

(Units : mm)

*All model could be customized. Please contact with Sunon Sales.

*Specifications are subject to change without notice. Please Visit SUNON web site at <http://www.sunon.com> for update information.

40x40x20 mm

6.3~10.8 CFM

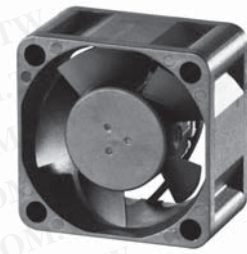

	Bearing	Rating Voltage (VDC)	Power Current (mA)	Power Consumption (WATTS)	Speed (RPM)	Air Flow (CFM)	Static Pressure (Inch-H ₂ O)	Noise (dBA)	Weight (g)	Curve
	● VAPO									
MB40200V1-0000-A99	●	5	190	0.95	7200	8.9	0.21	25.5	30.0	2
MB40200V2-0000-A99	●	5	123	0.32	6200	7.7	0.16	21.0	30.0	3
MB40200V3-0000-A99	●	5	81	0.41	5200	6.3	0.11	18.0	30.0	4
MB40201VX-0000-A99	●	12	115	1.38	8200	10.8	0.27	27.5	31.0	1
MB40201V1-0000-A99	●	12	70	0.84	7200	8.9	0.21	25.5	31.0	2
MB40201V2-0000-A99	●	12	50	0.60	6200	7.7	0.16	21.0	31.0	3
MB40201V3-0000-A99	●	12	40	0.48	5200	6.3	0.11	18.0	31.0	4
MB40202VX-0000-A99	●	24	64	1.54	8200	10.8	0.27	27.5	31.0	1
MB40202V1-0000-A99	●	24	50	1.20	7200	8.9	0.21	25.5	31.0	2
MB40202V2-0000-A99	●	24	33	0.80	6200	7.7	0.16	21.0	31.0	3

Model	2BALL Sleeve	(VDC)	(mA)	(WATTS)	(RPM)	(CFM)	(Inch-H ₂ O)	(dBA)	(g)	Curve
EB40200S1-0000-999	○	5	218	1.09	7200	8.9	0.21	25.5	30.0	2
EB40200S2-0000-999	○	5	140	0.70	6200	7.7	0.16	21.0	30.0	3
EB40200S3-0000-999	○	5	100	0.50	5200	6.3	0.11	18.0	30.0	4
EB40201SX-0000-999	○	12	120	1.44	8200	10.8	0.27	27.5	31.0	1
EB40201S1-0000-999	○	12	90	1.08	7200	8.9	0.21	25.5	31.0	2
EB40201S2-0000-999	○	12	63	0.76	6200	7.7	0.16	21.0	31.0	3
EB40201S3-0000-999	○	12	45	0.54	5200	6.3	0.11	18.0	31.0	4
EB40202S1-0000-999	○	24	54	1.30	7200	8.9	0.21	25.5	31.0	2
EB40202S2-0000-999	○	24	33	0.80	6200	7.7	0.16	21.0	31.0	3

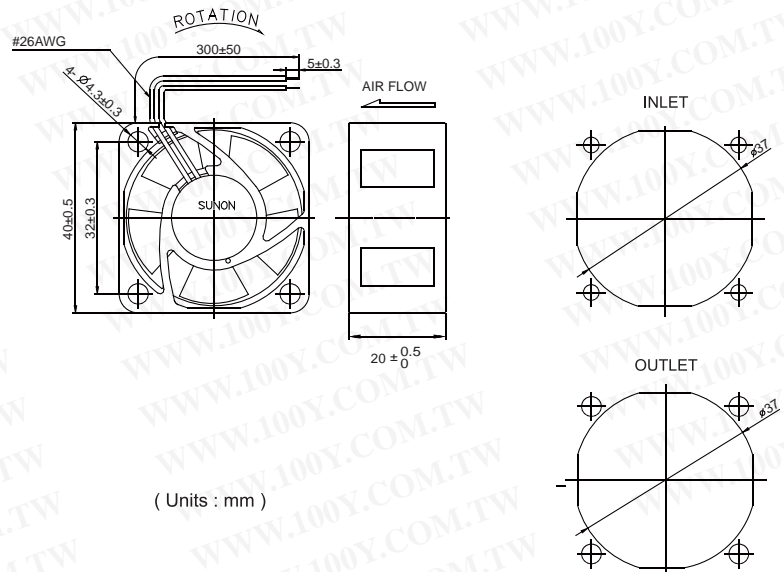
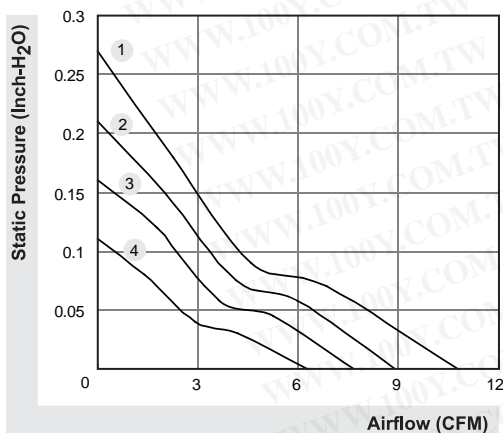

*All model could be customized. Please contact with Sunon Sales.

*Specifications are subject to change without notice. Please Visit SUNON web site at <http://www.sunon.com> for update information.

40x40x28 mm

24.9~31.3 CFM



Model	Bearing ⊙ 2BALL ○ Sleeve	Rating Voltage (VDC)	Power Current (mA)	Power Consumption (WATTS)	Speed (RPM)	Air Flow (CFM)	Static Pressure (Inch-H ₂ O)	Noise (dBA)	Weight (g)	Curve
PF40281BX-0000-A99	⊙	12	900	10.80	22000	31.3	2.81	66.6	42.0	1
PF40281B1-0000-A99	○	12	510	6.12	17600	24.9	1.95	58.8	42.0	2

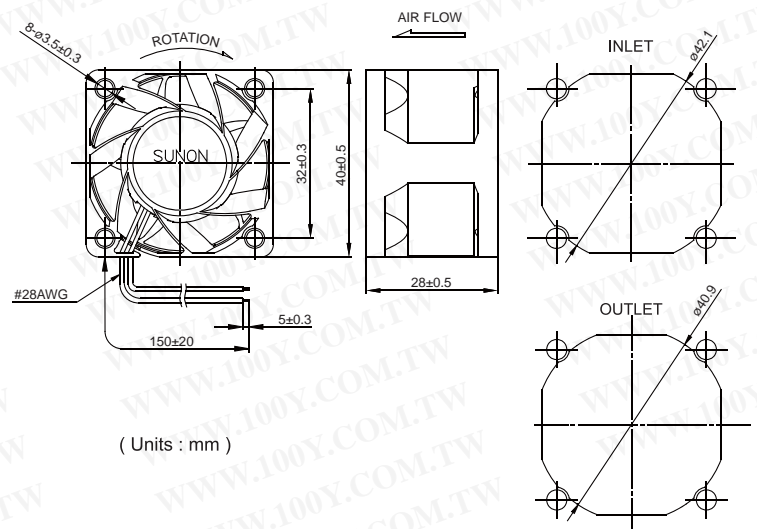
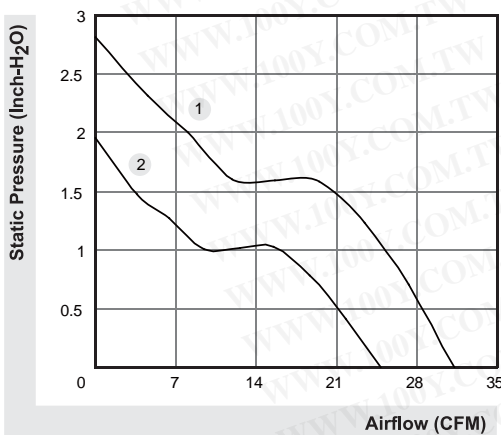

*All model could be customized. Please contact with Sunon Sales.

*Specifications are subject to change without notice. Please Visit SUNON web site at <http://www.sunon.com> for update information.

40x40x56 mm

26.9~31.7 CFM



Model	Bearing ● 2BALL ○ Sleeve	Rating Voltage (VDC)	Power Current (mA)	Power Consumption (WATTS)	Speed (RPM)	Air Flow (CFM)	Static Pressure (Inch-H ₂ O)	Noise (dBA)	Weight (g)	Curve
PF40561BX-0000-A99	●	12	1390	16.68	21500/18000	31.7	3.60	67.9	87.0	1
PF40561B1-0000-A99	○	12	890	10.68	18000/15000	26.9	2.56	64.3	87.0	2

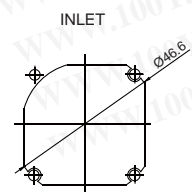
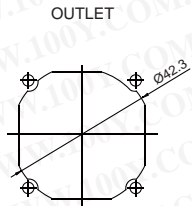
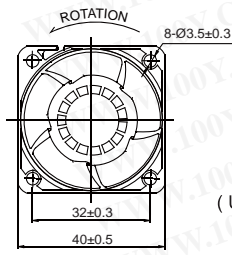
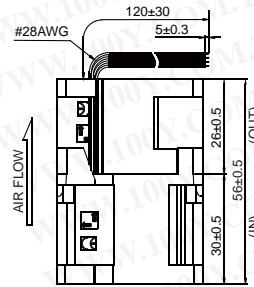
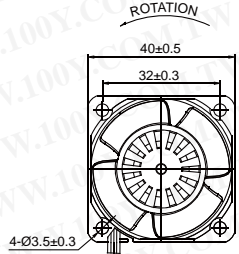
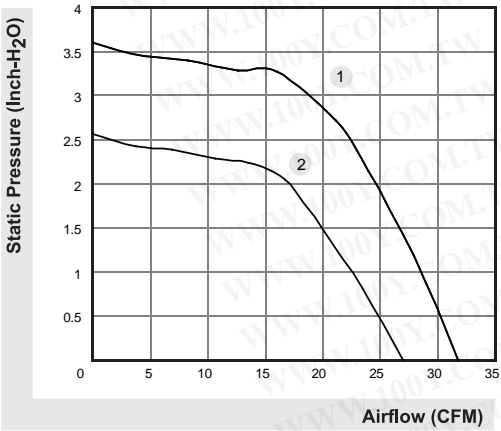

(Units : mm)

*All model could be customized. Please contact with Sunon Sales.
 *Specifications are subject to change without notice. Please Visit SUNON web site at <http://www.sunon.com> for update information.

45x45x10 mm

9.2~11.0 CFM

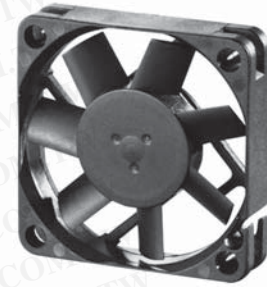

	Bearing	Rating Voltage (VDC)	Power Current (mA)	Power Consumption (WATTS)	Speed (RPM)	Air Flow (CFM)	Static Pressure (Inch-H ₂ O)	Noise (dBA)	Weight (g)	Curve
	● VAPO									
ME45100V1-0000-A99	●	5	223	1.12	6000	11.0	0.17	32.0	16.0	2
MB45100V2-0000-A99	●	5	230	1.15	5000	9.2	0.12	27.0	19.0	4
ME45101V1-0000-A99	●	12	110	1.32	6500	11.8	0.18	32.5	16.0	1
MB45101V2-0000-A99	●	12	105	1.26	5000	9.2	0.12	27.0	18.5	4

Model		(VDC)	(mA)	(WATTS)	(RPM)	(CFM)	(Inch-H ₂ O)	(dBA)	(g)	Curve
EE45100S1-0000-999	○	5	260	1.30	6000	11.0	0.17	32.0	16.0	2
EB45100S2-0000-999	○	5	240	1.20	5000	9.2	0.12	27.0	19.0	4
EE45101S1-0000-999	○	12	110	1.32	5700	10.5	0.16	31.0	16.0	3
EB45101S2-0000-999	○	12	120	1.44	5000	9.2	0.12	27.0	18.5	4

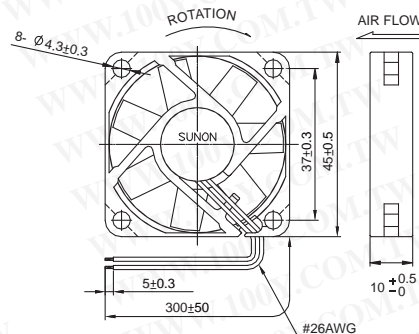
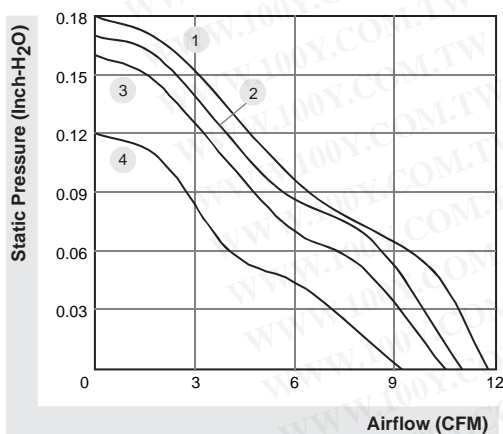

(Units : mm)

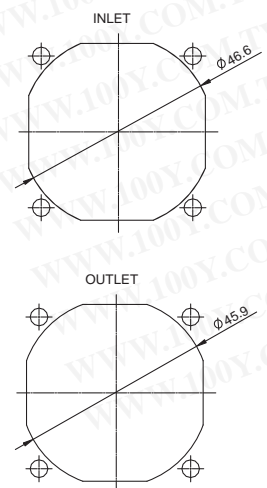

*All model could be customized. Please contact with Sunon Sales.

*Specifications are subject to change without notice. Please Visit SUNON web site at <http://www.sunon.com> for update information.

50x50x10 mm

11.0~13.8 CFM



	Bearing	Rating Voltage (VDC)	Power Current (mA)	Power Consumption (WATTS)	Speed (RPM)	Air Flow (CFM)	Static Pressure (Inch-H ₂ O)	Noise (dBA)	Weight (g)	Curve
	● VAPO									
ME50100V1-0000-A99	●	5	260	1.30	5200	13.0	0.14	30.0	17.5	2
MB50100V2-0000-A99	●	5	235	1.18	4300	11.0	0.11	26.0	21.0	4
ME50101V1-0000-A99	●	12	110	1.32	5500	13.8	0.15	31.0	17.5	1
MB50101V2-0000-A99	●	12	105	1.26	4300	11.0	0.11	26.0	20.0	4

Model		(VDC)	(m ³)	(WATTS)	(RPM)	(CFM)	(Inch-H ₂ O)	(dBA)	(g)	Curve
	○									
EE50100S1-0000-A99	○	5	275	1.38	5200	13.0	0.14	30.0	17.5	2
EB50100S2-0000-A99	○	5	245	1.23	4300	11.0	0.11	26.0	21.0	4
EE50101S1-0000-A99	○	12	110	1.32	5000	12.5	0.13	29.0	17.5	3
EB50101S2-0000-A99	○	12	120	1.44	4300	11.0	0.11	26.0	20.0	4

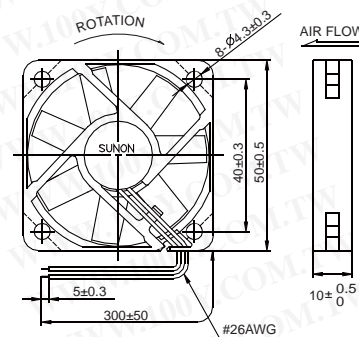
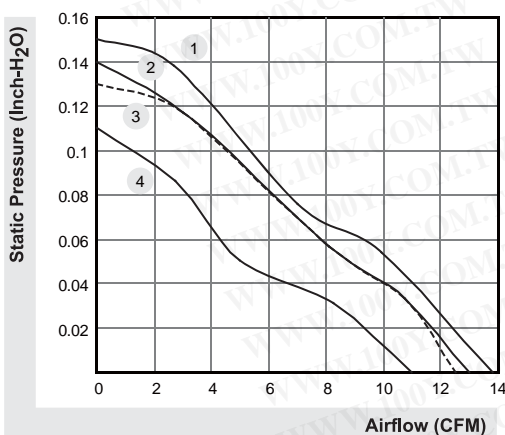

(Units : mm)

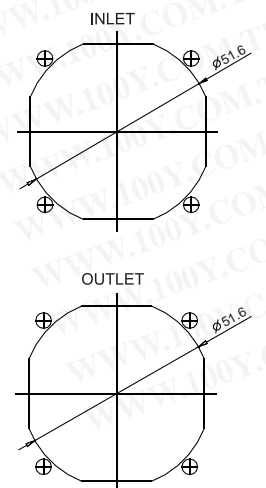

*All model could be customized. Please contact with Sunon Sales.

*Specifications are subject to change without notice. Please Visit SUNON web site at <http://www.sunon.com> for update information.

50x50x15 mm

10.2~17.0 CFM



	Bearing	Rating Voltage (VDC)	Power Current (mA)	Power Consumption (WATTS)	Speed (RPM)	Air Flow (CFM)	Static Pressure (Inch-H ₂ O)	Noise (dBA)	Weight (g)	Curve
	● VAPO									
MB50151V1-0000-A99	●	12	87	1.05	5800	17.0	0.23	33.0	38.8	1
MB50151V2-0000-A99	●	12	54	0.65	4700	13.0	0.17	29.0	38.8	2
MB50151V3-0000-A99	●	12	35	0.42	3700	10.2	0.12	22.0	38.8	3
MB50152V1-0000-A99	●	24	55	1.32	5800	17.0	0.23	33.0	37.8	1
MB50152V2-0000-A99	●	24	35	0.84	4700	13.0	0.17	29.0	37.8	2

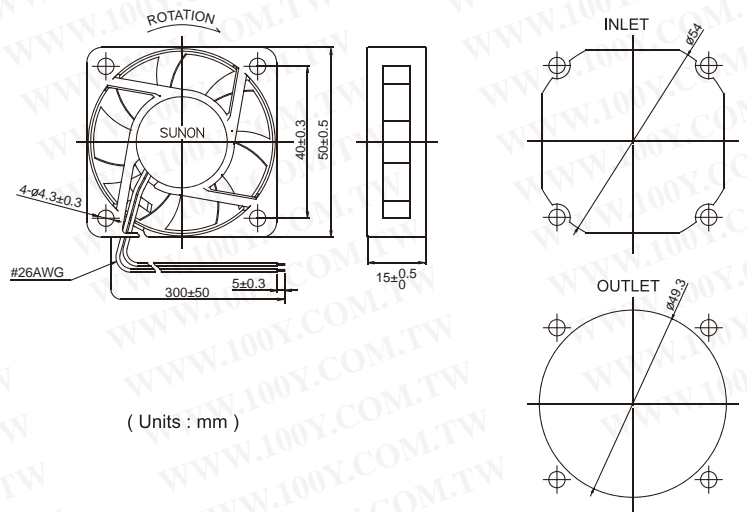
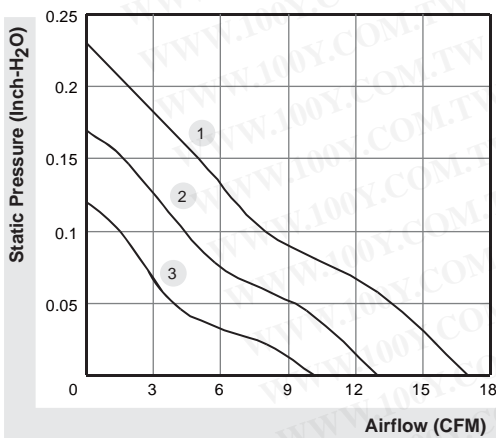

*All model could be customized. Please contact with Sunon Sales.

*Specifications are subject to change without notice. Please Visit SUNON web site at <http://www.sunon.com> for update information.

50x50x15 mm

12.9~18.6 CFM



	Bearing	Rating Voltage (VDC)	Power Current (mA)	Power Consumption (WATTS)	Speed (RPM)	Air Flow (CFM)	Static Pressure (Inch-H ₂ O)	Noise (dBA)	Weight (g)	Curve
	● VAPO									
ME50151V1-0000-A99	●	12	145	1.74	7000	18.6	0.26	40.1	27.6	1
ME50151V2-0000-A99	●	12	125	1.50	6100	16.1	0.20	36.0	27.6	2
ME50151V3-0000-A99	●	12	65	0.78	4900	12.9	0.14	30.1	27.6	3
ME50152V1-0000-A99	●	24	95	2.28	7000	18.6	0.26	40.1	27.6	1
ME50152V2-0000-A99	●	24	80	1.92	6100	16.1	0.20	36.0	27.6	2

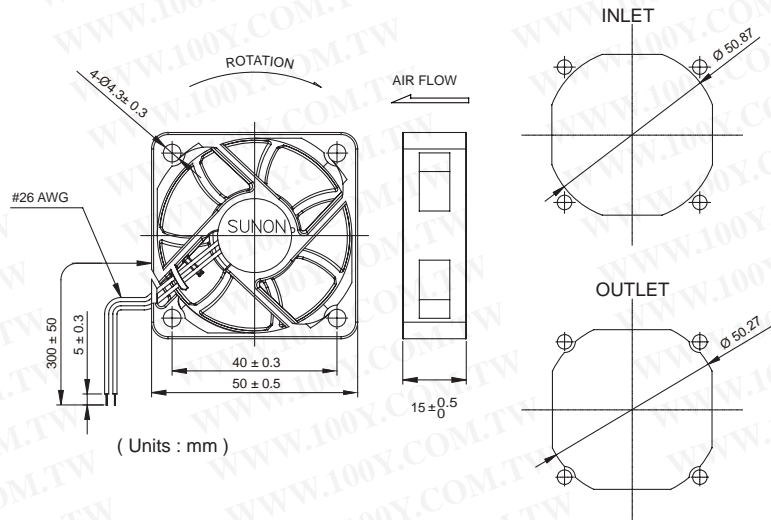
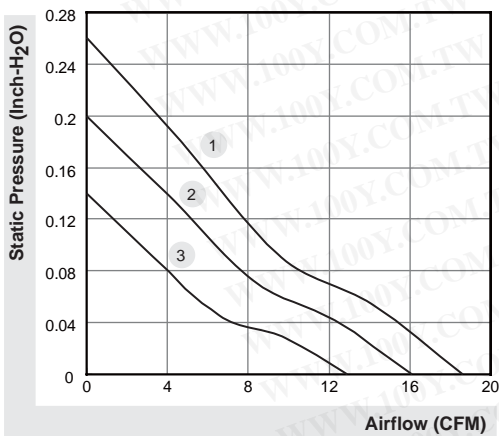

*All model could be customized. Please contact with Sunon Sales.

*Specifications are subject to change without notice. Please Visit SUNON web site at <http://www.sunon.com> for update information.

60x60x10 mm

11.7~16.0 CFM



	Bearing	Rating Voltage (VDC)	Power Current (mA)	Power Consumption (WATTS)	Speed (RPM)	Air Flow (CFM)	Static Pressure (Inch-H ₂ O)	Noise (dBA)	Weight (g)	Curve
	● VAPO									
MB60101V1-0000-A99	●	12	120	1.44	4000	16.0	0.12	28.5	29.0	1
MB60101V2-0000-A99	●	12	84	1.01	3500	13.6	0.10	25.0	29.0	2
MB60101V3-0000-A99	●	12	54	0.65	3000	11.7	0.08	21.5	29.0	3

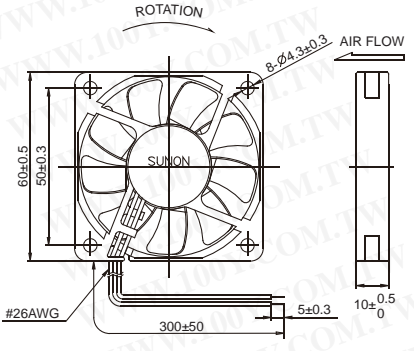
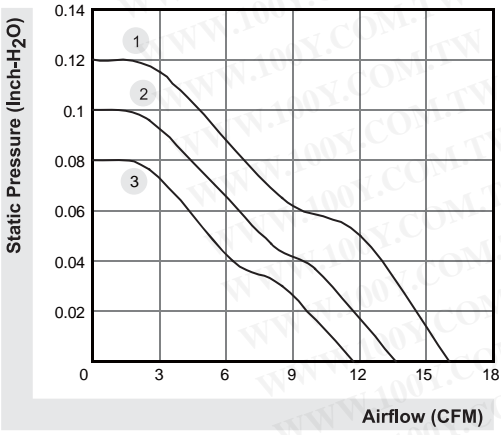

(Units : mm)

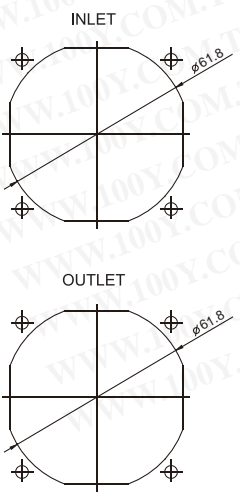

*All model could be customized. Please contact with Sunon Sales.
 *Specifications are subject to change without notice. Please Visit SUNON web site at <http://www.sunon.com> for update information.

60x60x15 mm

18.0~21.0 CFM



	P/N	Bearing	Rating Voltage (VDC)	Power Current (AMP)	Power Consumption (WATTS)	Speed (RPM)	Air Flow (CFM)	Static Pressure (Inch-H ₂ O)	Noise (dBA)	Weight (g)	Curve
	MB60151V1-0000-A99	●	12	130	1.56	4300	21.0	0.18	36.0	42.8	1
	MB60151V2-0000-A99	●	12	83	1.00	3800	18.0	0.14	31.0	42.8	2
	MB60151V3-0000-A99	●	12	50	0.60	3000	15.0	0.12	25.0	42.8	3
	MB60152V1-0000-A99	●	24	70	1.68	4300	21.0	0.18	36.0	42.6	1
	MB60152V2-0000-A99	●	24	45	1.08	3800	18.0	0.14	31.0	42.6	2

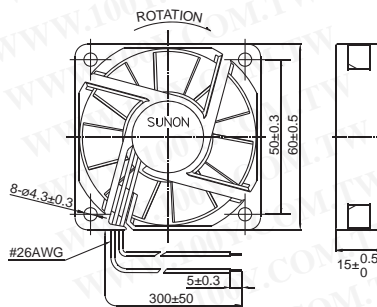
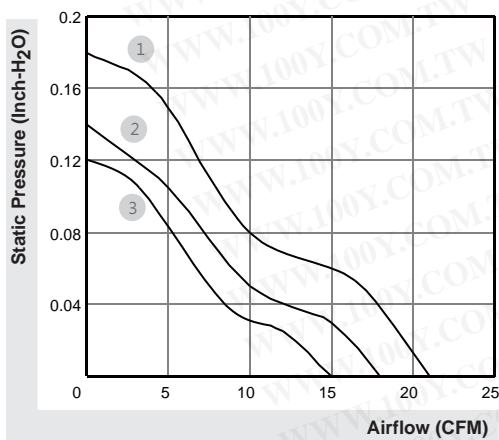

(Units : mm)

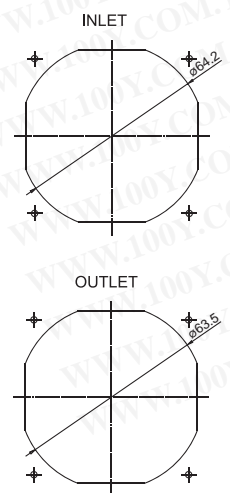

*All model could be customized. Please contact with Sunon Sales.

*Specifications are subject to change without notice. Please Visit SUNON web site at <http://www.sunon.com> for update information.

60x60x15 mm

18.1~25.2 CFM



	Bearing	Rating Voltage (VDC)	Power Current (mA)	Power Consumption (WATTS)	Speed (RPM)	Air Flow (CFM)	Static Pressure (Inch-H ₂ O)	Noise (dBA)	Weight (g)	Curve
	● VAPO									
ME60151V1-0000-A99	●	12	160	1.92	5400	25.2	0.15	36.2	30.5	1
ME60151V2-0000-A99	●	12	140	1.68	4700	21.9	0.12	32.5	30.5	2
ME60151V3-0000-A99	●	12	75	0.09	3900	18.1	0.08	28.2	30.5	3
ME60152V1-0000-A99	●	24	100	2.40	5400	25.2	0.15	36.2	30.5	1
ME60152V2-0000-A99	●	24	85	2.04	4700	21.9	0.12	32.5	30.5	2

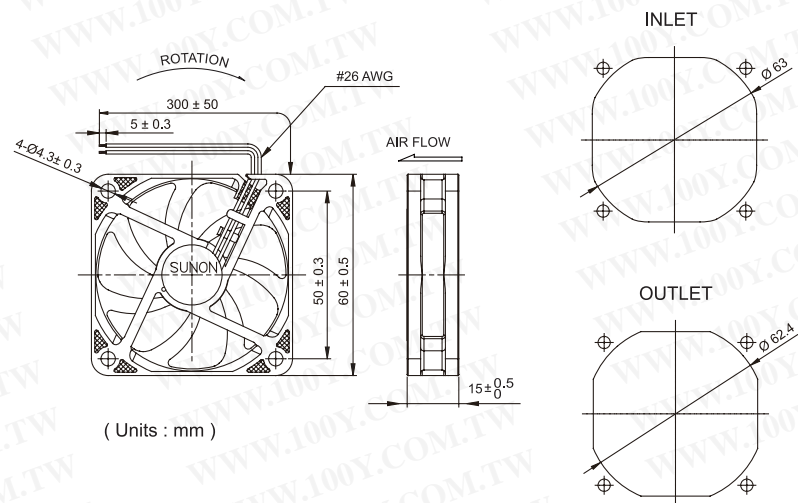
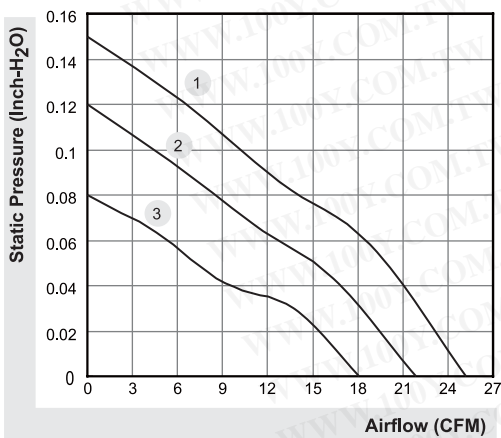

*All model could be customized. Please contact with Sunon Sales.

*Specifications are subject to change without notice. Please Visit SUNON web site at <http://www.sunon.com> for update information.

60x60x20 mm

16.0~30.5 CFM



	Bearing ● 2BALL ○ Sleeve	Rating Voltage (VDC)	Power Current (mA)	Power Consumption (WATTS)	Speed (RPM)	Air Flow (CFM)	Static Pressure (Inch-H ₂ O)	Noise (dBA)	Weight (g)	Curve
PE60201BX-0000-A99	●	12	230	2.76	5500	30.5	0.35	41.0	52.0	1
PE60201B1-0000-A99	●	12	192	2.30	5000	27.5	0.28	39.0	52.0	2
PE60201B2-0000-A99	●	12	148	1.78	4400	23.5	0.20	35.0	52.0	3
PE60201B3-0000-A99	●	12	103	1.24	3600	19.5	0.15	30.0	52.0	4
PE60201B4-0000-A99	●	12	81	0.97	3000	16.0	0.10	24.0	52.0	5

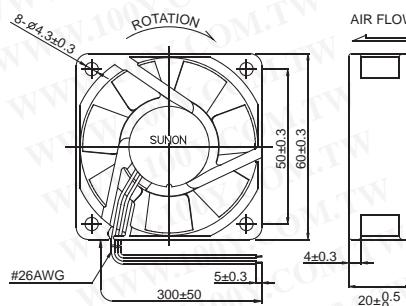
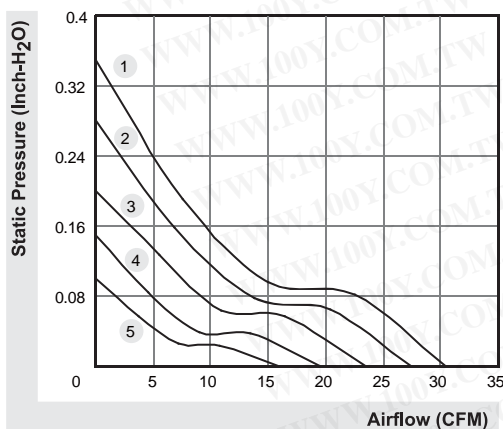

(Units : mm)

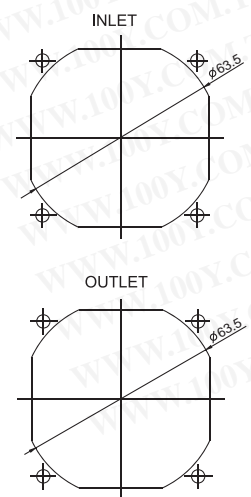

*All model could be customized. Please contact with Sunon Sales.

*Specifications are subject to change without notice. Please Visit SUNON web site at <http://www.sunon.com> for update information.

60x60x20 mm

16.5~25.5 CFM



	Bearing	Rating Voltage (VDC)	Power Current (mA)	Power Consumption (WATTS)	Speed (RPM)	Air Flow (CFM)	Static Pressure (Inch-H ₂ O)	Noise (dBA)	Weight (g)	Curve
	● VAPO									
MB60201VX-0000-A99	●	12	210	2.52	5100	25.5	0.24	39.0	51.0	1
MB60201V1-0000-A99	●	12	135	1.62	4500	23.0	0.18	33.5	51.0	2
MB60201V2-0000-A99	●	12	79	0.95	3700	19.0	0.14	29.0	51.0	3
MB60201V3-0000-A99	●	12	50	0.60	3000	16.5	0.10	23.0	51.0	4
MB60202VX-0000-A99	●	24	115	2.76	5100	25.5	0.24	39.0	51.0	1
MB60202V1-0000-A99	●	24	75	1.80	4500	23.0	0.18	33.5	51.0	2
MB60202V2-0000-A99	●	24	48	1.16	3700	19.0	0.14	28.0	51.0	3
MB60202V3-0000-A99	●	24	33	0.80	3000	16.5	0.10	23.0	51.0	4

Model		(VDC)	(mA)	(WATTS)	(RPM)	(CFM)	(Inch-H ₂ O)	(dBA)	(g)	Curve
EB60201S1-0000-999	○	12	153	1.84	4500	23.0	0.18	33.5	51.0	2
EB60201S2-0000-999	○	12	89	1.07	3700	19.0	0.14	28.0	51.0	3
EB60201S3-0000-999	○	12	58	0.70	3000	16.5	0.10	23.0	51.0	4

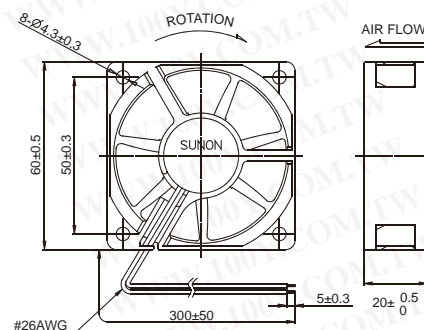
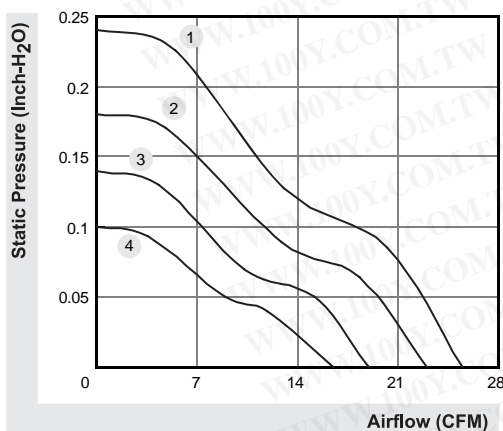

(Units : mm)

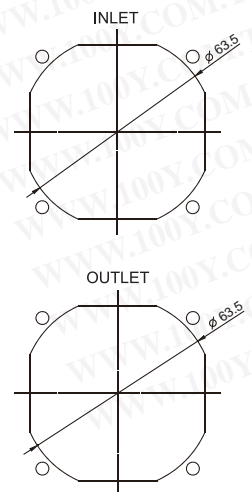

*All model could be customized. Please contact with Sunon Sales.

*Specifications are subject to change without notice. Please Visit SUNON web site at <http://www.sunon.com> for update information.

60x60x25 mm

29.0~40.0 CFM



	Bearing ● 2BALL ○ Sleeve	Rating Voltage (VDC)	Power Current (mA)	Power Consumption (WATTS)	Speed (RPM)	Air Flow (CFM)	Static Pressure (Inch-H ₂ O)	Noise (dBA)	Weight (g)	Curve
PE60251BX-0000-A99	●	12	370	4.44	7600	40.0	0.64	46.0	71.0	1
PE60251B1-0000-A99	●	12	297	3.57	6900	36.0	0.54	44.0	71.0	2
PE60251B2-0000-A99	●	12	232	2.79	6100	31.5	0.42	42.0	71.0	3
PE60251B3-0000-A99	●	12	197	2.37	5600	29.0	0.36	38.0	71.0	4
PE60252BX-0000-A99	●	24	190	4.56	7600	40.0	0.64	46.0	75.0	1
PE60252B1-0000-A99	●	24	155	3.72	6900	36.0	0.54	44.0	75.0	2
PE60252B2-0000-A99	●	24	121	2.91	6100	31.5	0.42	42.0	75.0	3
PE60252B3-0000-A99	●	24	104	2.50	5600	29.0	0.36	38.0	75.0	4

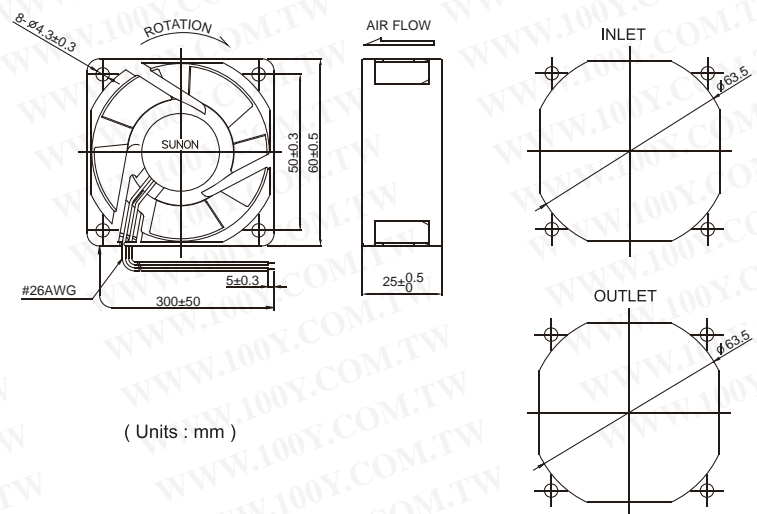
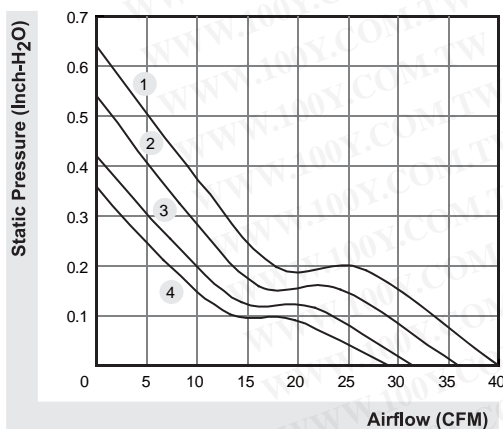

*All model could be customized. Please contact with Sunon Sales.

*Specifications are subject to change without notice. Please Visit SUNON web site at <http://www.sunon.com> for update information.

60x60x25 mm

16.0~27.0 CFM



	Bearing	Rating Voltage (VDC)	Power Current (mA)	Power Consumption (WATTS)	Speed (RPM)	Air Flow (CFM)	Static Pressure (Inch-H ₂ O)	Noise (dBA)	Weight (g)	Curve
	● VAPO									
MB60251VX-0000-A99	●	12	200	2.40	5200	27.0	0.31	36.5	57.0	1
MB60251V1-0000-A99	●	12	125	1.50	4500	23.5	0.21	33.5	57.0	2
MB60251V2-0000-A99	●	12	74	0.89	3800	19.3	0.15	29.0	57.0	3
MB60251V3-0000-A99	●	12	50	0.60	3100	16.0	0.10	21.0	57.0	4
MB60252VX-0000-A99	●	24	110	2.64	5200	27.0	0.31	36.5	57.0	1
MB60252V1-0000-A99	●	24	70	1.68	4500	23.5	0.21	33.5	57.0	2
MB60252V2-0000-A99	●	24	48	1.16	3800	19.3	0.15	29.0	57.0	3
MB60252V3-0000-A99	●	24	32	0.77	3100	16.0	0.10	21.0	57.0	4

Model		(VDC)	(mA)	(WATTS)	(RPM)	(CFM)	(Inch-H ₂ O)	(dBA)	(g)	Curve
EB60251S1-0000-999	○	12	135	1.62	4500	23.5	0.21	33.5	55.0	2
EB60251S2-0000-999	○	12	89	1.07	3800	19.3	0.15	29.0	55.0	3
EB60251S3-0000-999	○	12	64	0.77	3100	16.0	0.10	21.0	55.0	4
EB60252S1-0000-999	○	24	75	1.80	4500	23.5	0.21	33.5	57.0	2
EB60252S2-0000-999	○	24	48	1.16	3800	19.3	0.15	29.0	57.0	3
EB60252S3-0000-999	○	24	35	0.84	3100	16.0	0.10	21.0	57.0	4

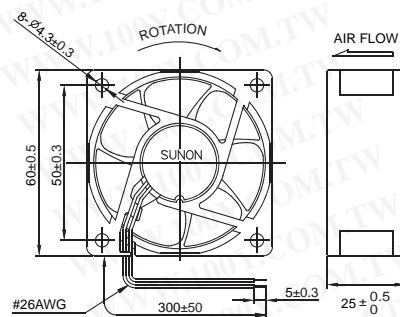
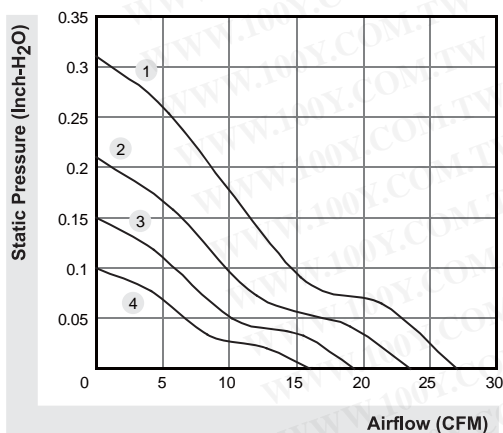

(Units : mm)

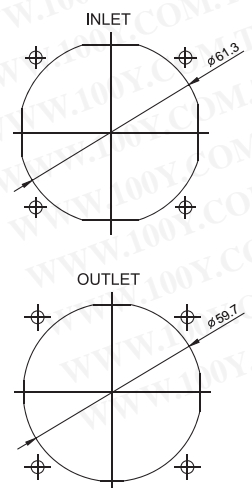

*All model could be customized. Please contact with Sunon Sales.

*Specifications are subject to change without notice. Please Visit SUNON web site at <http://www.sunon.com> for update information.

60x60x25 mm

13.9~23.5 CFM



	Bearing ● 2BALL ○ Sleeve	Rating Voltage (VDC)	Power Current (mA)	Power Consumption (WATTS)	Speed (RPM)	Air Flow (CFM)	Static Pressure (Inch-H ₂ O)	Noise (dBA)	Weight (g)	Curve
EE60251B1-0000-999	●	12	120	1.44	4500	23.5	0.21	34.5	50.0	1
EE60251B2-0000-999	●	12	70	0.84	3800	19.3	0.15	30.0	50.0	2
EE60251B3-0000-999	●	12	47	0.56	3000	13.9	0.08	20.0	50.0	3
EE60252B1-0000-A99	○	24	70	1.68	4500	23.5	0.21	34.5	50.0	1
EE60252B2-0000-A99	○	24	45	1.08	3800	19.3	0.15	30.0	50.0	2
EE60252B3-0000-A99	○	24	25	0.60	3000	13.9	0.08	20.0	50.0	3

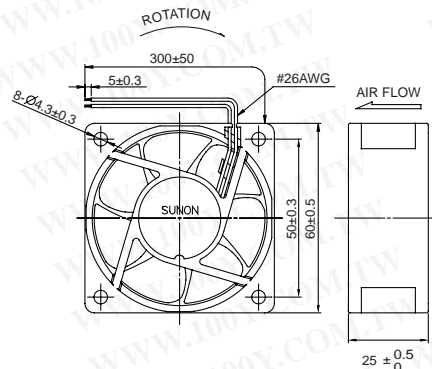
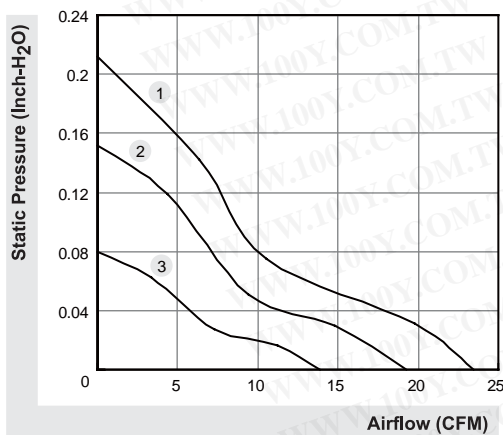

(Units : mm)

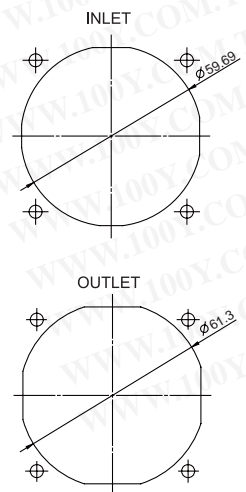

*All model could be customized. Please contact with Sunon Sales.

*Specifications are subject to change without notice. Please Visit SUNON web site at <http://www.sunon.com> for update information.

70x70x10 mm

14.5~20.5 CFM



	Bearing	Rating Voltage (VDC)	Power Current (mA)	Power Consumption (WATTS)	Speed (RPM)	Air Flow (CFM)	Static Pressure (Inch-H ₂ O)	Noise (dBA)	Weight (g)	Curve
	● VAPO									
MB70101V1-0000-A99	●	12	138	1.66	3000	20.5	0.08	28.0	29.0	1
MB70101V2-0000-A99	●	12	90	1.08	2500	17.0	0.06	24.5	29.0	2
MB70101V3-0000-A99	●	12	60	0.72	2100	14.5	0.05	20.5	29.0	3

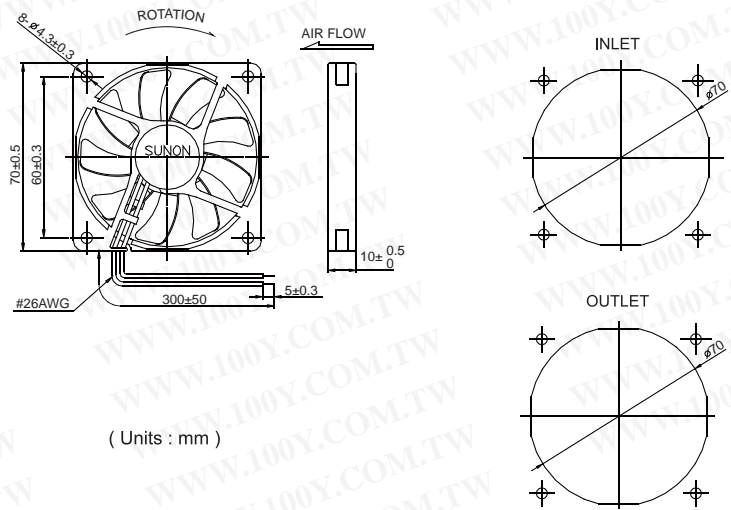
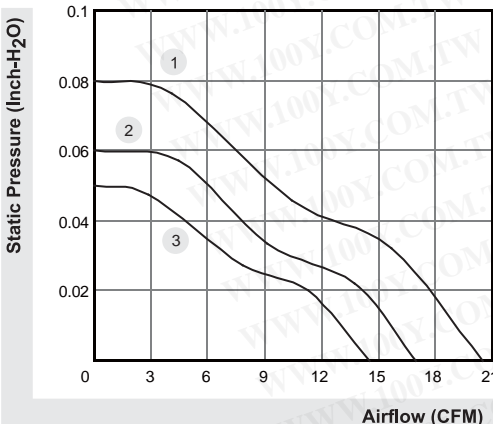

(Units : mm)

*All model could be customized. Please contact with Sunon Sales.
 *Specifications are subject to change without notice. Please Visit SUNON web site at <http://www.sunon.com> for update information.

70x70x20 mm

43.0~37.0 CFM



	Bearing	Rating Voltage (VDC)	Power Current (mA)	Power Consumption (WATTS)	Speed (RPM)	Air Flow (CFM)	Static Pressure (Inch-H ₂ O)	Noise (dBA)	Weight (g)	Curve
	PF70201V1-0000-A99	● VAPO	12	285	3.42	4600	43.0	0.28	41.5	80.0
PF70201V2-0000-A99	●	12	230	2.76	4300	40.0	0.24	40.0	80.0	2
PF70201V3-0000-A99	●	12	195	2.34	4000	37.0	0.21	37.5	80.0	3

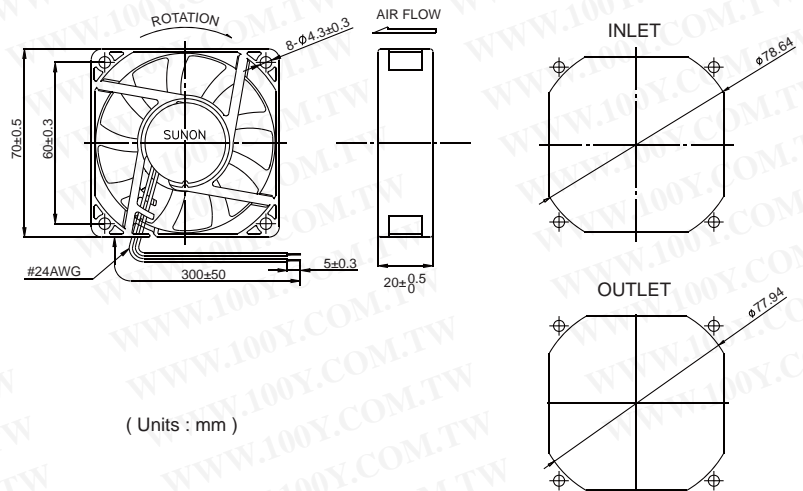
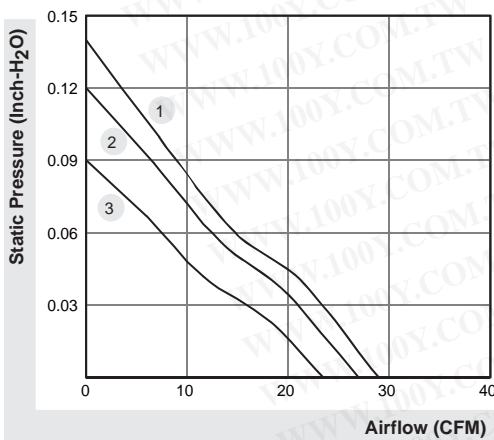

*All model could be customized. Please contact with Sunon Sales.

*Specifications are subject to change without notice. Please Visit SUNON web site at <http://www.sunon.com> for update information.

70x70x20 mm

23.5~29.0 CFM



	Bearing	Rating Voltage (VDC)	Power Current (mA)	Power Consumption (WATTS)	Speed (RPM)	Air Flow (CFM)	Static Pressure (Inch-H ₂ O)	Noise (dBA)	Weight (g)	Curve
	● VAPO									
ME70201V1-0000-A99	●	12	130	1.56	3200	29.0	0.14	33.0	60.0	1
ME70201V2-0000-A99	●	12	99	1.19	2900	27.0	0.12	30.0	60.0	2
ME70201V3-0000-A99	●	12	77	0.93	2600	23.5	0.09	26.0	60.0	3
ME70202V1-0000-A99	●	24	66	1.59	3200	29.0	0.14	33.0	60.0	1
ME70202V2-0000-A99	●	24	56	1.35	2900	27.0	0.12	30.0	60.0	2
ME70202V3-0000-A99	●	24	44	1.06	2600	23.5	0.09	26.0	60.0	3

Model	○ 2BALL Sleeve	(VDC)	(mA)	(WATTS)	(RPM)	(CFM)	(Inch-H ₂ O)	(dBA)	(g)	Curve
EE70201S1-0000-A99	○	12	135	1.62	3200	29.0	0.14	33.0	60.0	1
EE70201S2-0000-999	○	12	110	1.32	2900	27.0	0.12	30.0	60.0	2
EE70201S3-0000-999	○	12	90	1.08	2600	23.5	0.09	26.0	60.0	3
EE70202S1-0000-A99	○	24	64	1.54	3200	29.0	0.14	33.0	60.0	1
EE70202S2-0000-999	○	24	55	1.32	2900	27.0	0.12	30.0	60.0	2
EE70202S3-0000-999	○	24	44	1.06	2600	23.5	0.09	26.0	60.0	3

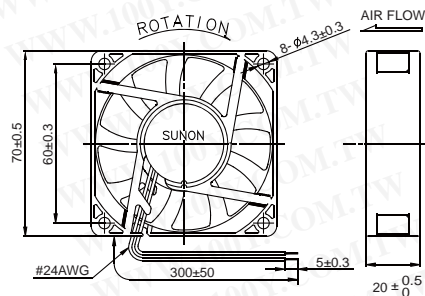
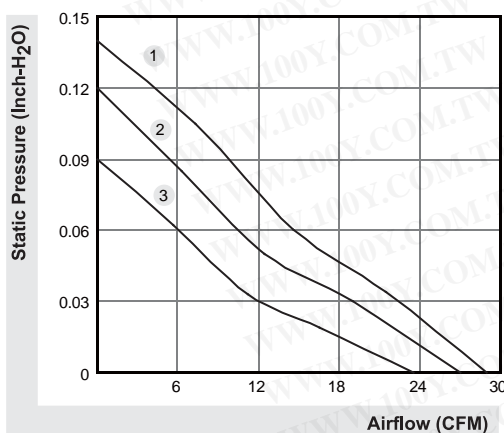

(Units : mm)

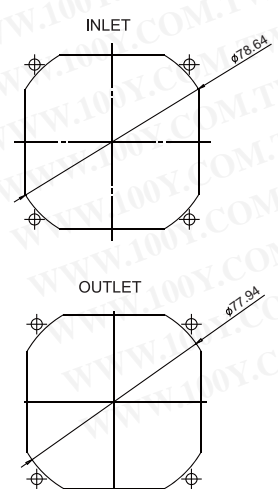

*All model could be customized. Please contact with Sunon Sales.

*Specifications are subject to change without notice. Please Visit SUNON web site at <http://www.sunon.com> for update information.

80x80x15 mm

30.0~37.0 CFM



	Bearing	Rating Voltage (VDC)	Power Current (mA)	Power Consumption (WATTS)	Speed (RPM)	Air Flow (CFM)	Static Pressure (Inch-H ₂ O)	Noise (dBA)	Weight (g)	Curve
	● VAPO									
ME80151V1-0000-A99	●	12	163	1.96	3000	37.0	0.14	34.7	68.0	1
ME80151V2-0000-A99	●	12	129	1.55	2700	33.6	0.11	32.0	68.0	2
ME80151V3-0000-A99	●	12	90	1.08	2400	30.0	0.09	30.8	68.0	3
ME80152V1-0000-A99	●	24	92	2.21	3000	37.0	0.14	34.7	68.0	1
ME80152V2-0000-A99	●	24	65	1.56	2700	33.6	0.11	32.0	68.0	2
ME80152V3-0000-A99	●	24	56	1.35	2400	30.0	0.09	30.8	68.0	3

Model	○ 2BALL Sleeve	(VDC)	(mA)	(WATTS)	(RPM)	(CFM)	(Inch-H ₂ O)	(dBA)	(g)	Curve
EE80151S1-0000-A99	○	12	163	1.96	3000	37.0	0.14	34.7	68.0	1
EE80151S2-0000-999	○	12	134	1.61	2700	33.6	0.11	32.0	68.0	2
EE80151S3-0000-999	○	12	100	1.20	2400	30.0	0.09	30.8	68.0	3
EE80152S1-0000-A99	○	24	99	2.38	3000	37.0	0.14	34.7	68.0	1
EE80152S2-0000-999	○	24	65	1.56	2700	33.6	0.11	32.0	68.0	2
EE80152S3-0000-999	○	24	54	1.30	2400	30.0	0.09	30.8	68.0	3

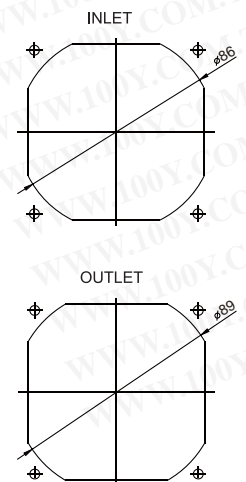
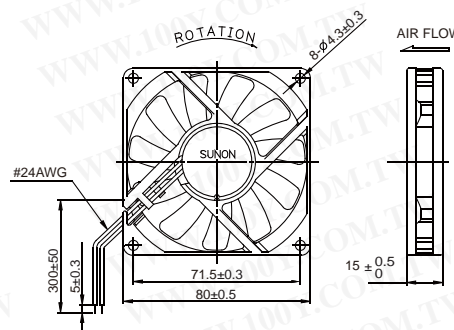
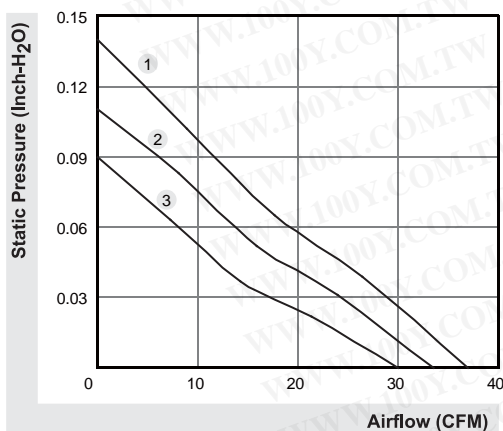

(Units : mm)

*All model could be customized. Please contact with Sunon Sales.

*Specifications are subject to change without notice. Please Visit SUNON web site at <http://www.sunon.com> for update information.

80x80x20 mm

53.0~45.0 CFM



	Bearing	Rating Voltage (VDC)	Power Current (mA)	Power Consumption (WATTS)	Speed (RPM)	Air Flow (CFM)	Static Pressure (Inch-H ₂ O)	Noise (dBA)	Weight (g)	Curve
	PF80201V1-0000-A99	● VAPO	12	285	3.42	4600	53.0	0.36	48.0	85.0
PF80201V2-0000-A99	●	12	230	2.76	4200	49.0	0.31	45.0	85.0	2
PF80201V3-0000-A99	●	12	195	2.34	3900	45.0	0.26	43.0	85.0	3

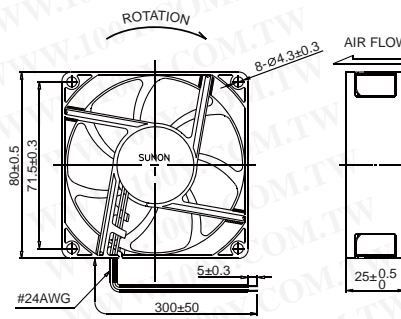
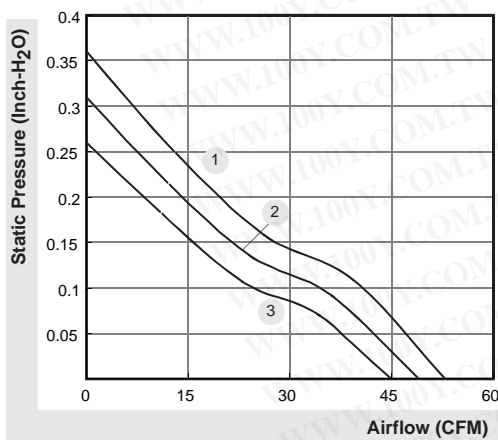

(Units : mm)

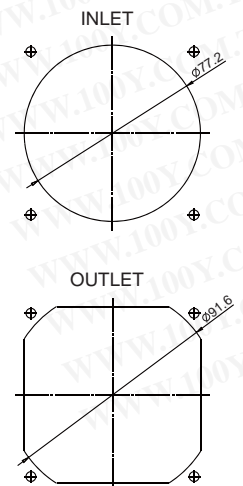

*All model could be customized. Please contact with Sunon Sales.

*Specifications are subject to change without notice. Please Visit SUNON web site at <http://www.sunon.com> for update information.

80x80x20 mm

29.0~36.0 CFM



	Bearing	Rating Voltage (VDC)	Power Current (mA)	Power Consumption (WATTS)	Speed (RPM)	Air Flow (CFM)	Static Pressure (Inch-H ₂ O)	Noise (dBA)	Weight (g)	Curve
	● VAPO									
ME80201V1-0000-A99	●	12	130	1.56	3300	36.0	0.18	38.0	66.0	1
ME80201V2-0000-A99	●	12	95	1.14	3000	33.0	0.16	35.0	66.0	2
ME80201V3-0000-A99	●	12	74	0.89	2600	29.0	0.12	30.0	66.0	3
ME80202V1-0000-A99	●	24	64	1.54	3300	36.0	0.18	38.0	66.0	1
ME80202V2-0000-A99	●	24	51	1.23	3000	33.0	0.16	35.0	66.0	2
ME80202V3-0000-A99	●	24	42	1.01	2600	29.0	0.12	30.0	66.0	3

Model	○ 2BALL Sleeve	(VDC)	(mA)	(WATTS)	(RPM)	(CFM)	(Inch-H ₂ O)	(dBA)	(g)	Curve
EE80201S1-0000-A99	○	12	130	1.56	3300	36.0	0.18	38.0	66.0	1
EE80201S2-0000-999	○	12	110	1.32	3000	33.0	0.16	35.0	66.0	2
EE80201S3-0000-999	○	12	83	1.00	2600	29.0	0.12	30.0	66.0	3
EE80202S1-0000-A99	○	24	64	1.54	3300	36.0	0.18	38.0	66.0	1
EE80202S2-0000-999	○	24	55	1.32	3000	33.0	0.16	35.0	66.0	2
EE80202S3-0000-999	○	24	44	1.06	2600	29.0	0.12	30.0	66.0	3

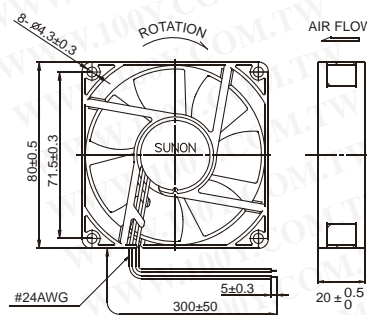
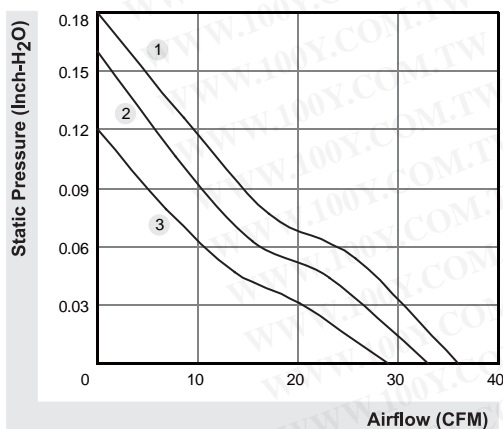

(Units : mm)

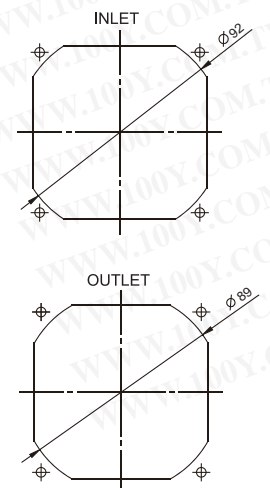

*All model could be customized. Please contact with Sunon Sales.

*Specifications are subject to change without notice. Please Visit SUNON web site at <http://www.sunon.com> for update information.

80x80x25 mm

53.0~60.0 CFM



	Bearing	Rating Voltage (VDC)	Power Current (mA)	Power Consumption (WATTS)	Speed (RPM)	Air Flow (CFM)	Static Pressure (Inch-H ₂ O)	Noise (dBA)	Weight (g)	Curve
	● VAPO									
PF80251V1-0000-A99	●	12	341	4.10	4800	60.0	0.41	46.5	91.0	1
PF80251V2-0000-A99	●	12	285	3.40	4500	57.0	0.35	45.0	91.0	2
PF80251V3-0000-A99	●	12	223	2.70	4200	53.0	0.30	43.5	91.0	3
PE80252V1-0000-A99	●	24	200	4.80	4800	60.0	0.41	46.5	91.0	1
PE80252V2-0000-A99	●	24	166	3.99	4500	57.0	0.35	45.0	91.0	2
PE80252V3-0000-A99	●	24	137	3.29	4200	53.0	0.30	43.5	91.0	3
PE80254V1-0000-A99	●	48	114	5.48	4800	60.0	0.41	46.5	91.0	1
PE80254V2-0000-A99	●	48	100	4.80	4500	57.0	0.35	45.0	91.0	2
PE80254V3-0000-A99	●	48	92	4.42	4200	53.0	0.30	43.5	91.0	3

Model		(VDC)	(mA)	(WATTS)	(RPM)	(CFM)	(Inch-H ₂ O)	(dBA)	(g)	Curve
PF80251B1-0000-A99	☉	12	341	4.10	4800	60.0	0.41	47.5	91.0	1
PF80251B2-0000-A99	☉	12	285	3.40	4500	57.0	0.35	46.0	91.0	2
PF80251B3-0000-A99	☉	12	223	2.70	4200	53.0	0.30	44.5	91.0	3
PE80252B1-0000-A99	☉	24	200	4.80	4800	60.0	0.41	47.5	91.0	1
PE80252B2-0000-A99	☉	24	166	3.99	4500	57.0	0.35	46.0	91.0	2
PE80252B3-0000-A99	☉	24	137	3.29	4200	53.0	0.30	44.5	91.0	3
PE80254B1-0000-A99	☉	48	114	5.48	4800	60.0	0.41	47.5	91.0	1
PE80254B2-0000-A99	☉	48	100	4.80	4500	57.0	0.35	46.0	91.0	2
PE80254B3-0000-A99	☉	48	92	4.42	4200	53.0	0.30	44.5	91.0	3

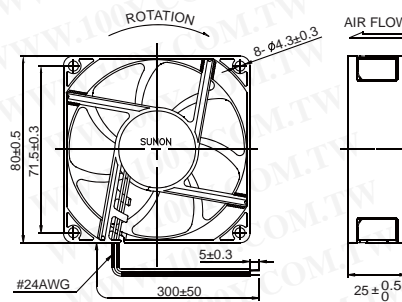
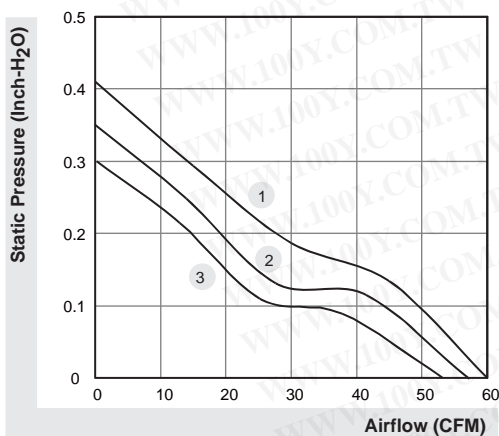

(Units : mm)

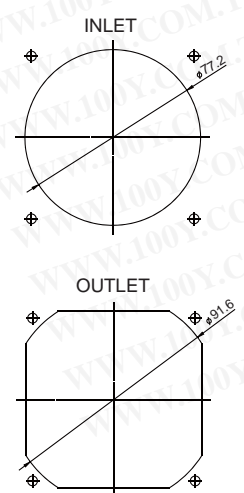

*All model could be customized. Please contact with Sunon Sales.

*Specifications are subject to change without notice. Please Visit SUNON web site at <http://www.sunon.com> for update information.

80x80x25 mm

33.0~45.0 CFM



	Bearing	Rating Voltage (VDC)	Power Current (mA)	Power Consumption (WATTS)	Speed (RPM)	Air Flow (CFM)	Static Pressure (Inch-H ₂ O)	Noise (dBA)	Weight (g)	Curve
	● VAPO									
ME80251VX-0000-A99	●	12	160	1.9	3600	45.0	0.23	37.0	89.0	1
ME80251V1-0000-A99	●	12	145	1.7	3200	41.0	0.18	33.0	77.0	2
ME80251V2-0000-A99	●	12	120	1.4	2900	37.0	0.15	30.0	75.0	3
ME80251V3-0000-A99	●	12	81	1.1	2600	33.0	0.11	28.0	75.0	4
ME80252VX-0000-A99	●	24	90	2.2	3600	45.0	0.23	37.0	89.0	1
ME80252V1-0000-A99	●	24	73	1.8	3200	41.0	0.18	33.0	75.0	2
ME80252V2-0000-A99	●	24	59	1.4	2900	37.0	0.15	30.0	75.0	3
ME80252V3-0000-A99	●	24	49	1.2	2600	33.0	0.11	28.0	75.0	4

Model		(VDC)	(mA)	(WATTS)	(RPM)	(CFM)	(Inch-H ₂ O)	(dBA)	(g)	Curve
EE80251BX-0000-A99	⊕	12	150	1.80	3600	45.0	0.23	38.0	89.0	1
EE80251B1-0000-A99	⊕	12	145	1.70	3200	41.0	0.18	33.0	75.0	2
EE80251B2-0000-999	⊕	12	120	1.40	2900	37.0	0.15	30.0	75.0	3
EE80251B3-0000-999	⊕	12	90	1.10	2600	33.0	0.11	28.0	75.0	4
EE80252BX-0000-A99	⊕	24	80	1.92	3600	45.0	0.23	38.0	89.0	1
EE80252B1-0000-A99	⊕	24	73	1.80	3200	41.0	0.18	33.0	75.0	2
EE80252B2-0000-999	⊕	24	64	1.50	2900	37.0	0.15	30.0	75.0	3
EE80252B3-0000-999	⊕	24	50	1.20	2600	33.0	0.11	28.0	75.0	4
EE80251S1-0000-A99	○	12	145	1.70	3200	41.0	0.18	33.0	75.0	2
EE80251S2-0000-999	○	12	120	1.40	2900	37.0	0.15	30.0	75.0	3
EE80251S3-0000-999	○	12	90	1.10	2600	33.0	0.11	28.0	75.0	4
EE80252S1-0000-A99	○	24	73	1.80	3200	41.0	0.18	33.0	75.0	2
EE80252S2-0000-999	○	24	64	1.50	2900	37.0	0.15	30.0	75.0	3
EE80252S3-0000-999	○	24	52	1.30	2600	33.0	0.11	28.0	75.0	4

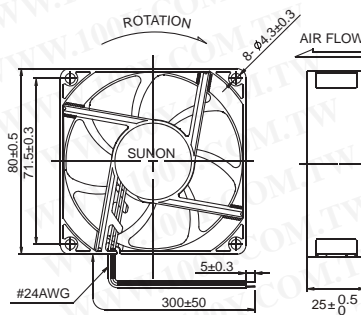
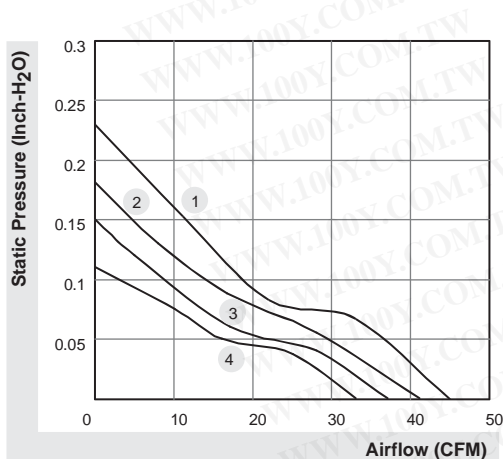

(Units : mm)

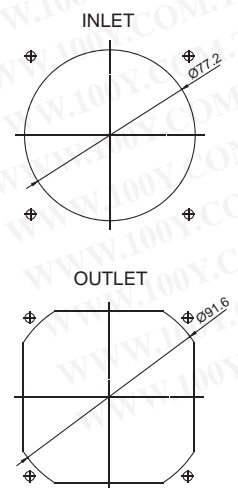

*All model could be customized. Please contact with Sunon Sales.

*Specifications are subject to change without notice. Please Visit SUNON web site at <http://www.sunon.com> for update information.

80x80x32 mm

50.3~59.4 CFM



Model	P/N	Bearing ● 2BALL ○ Sleeve	Rating Voltage (VDC)	Power Current (mA)	Power Consumption (WATTS)	Speed (RPM)	Air Flow (CFM)	Static Pressure (Inch-H ₂ O)	Noise (dBA)	Weight (g)	Curve
PF80321B1-0000-A99		●	12	310	3.7	4800	59.4	0.36	45.2	96.0	1
PF80321B2-0000-A99		●	12	230	2.8	4500	55.9	0.32	43.1	96.0	2
PF80321B3-0000-A99		●	12	200	2.4	4100	50.3	0.27	41.1	96.0	3

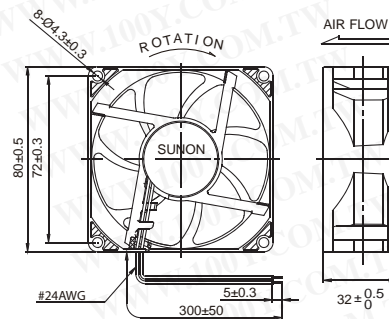
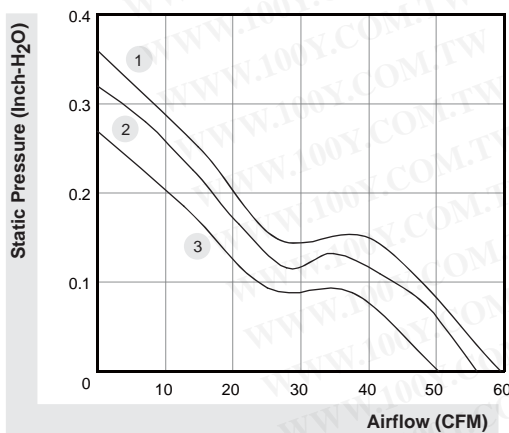

(Units : mm)

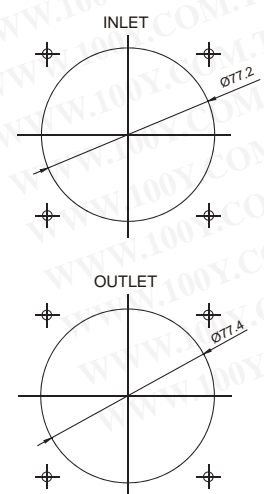

*All model could be customized. Please contact with Sunon Sales.

*Specifications subject to change without notice. Please Visit SUNON web site at <http://www.sunon.com> for update information.

92x92x25 mm

65.0~75.0 CFM



	Bearing	Rating Voltage (VDC)	Power Current (mA)	Power Consumption (WATTS)	Speed (RPM)	Air Flow (CFM)	Static Pressure (Inch-H ₂ O)	Noise (dBA)	Weight (g)	Curve
	● VAPO									
PF92251V1-0000-A99	●	12	393	4.70	4500	75.0	0.35	46.0	103.0	1
PF92251V2-0000-A99	●	12	325	3.90	4200	70.0	0.30	44.0	103.0	2
PF92251V3-0000-A99	●	12	260	3.10	3900	65.0	0.25	42.0	103.0	3
PE92252V1-0000-A99	●	24	220	5.28	4500	75.0	0.35	46.0	103.0	1
PE92252V2-0000-A99	●	24	180	4.32	4200	70.0	0.30	44.0	103.0	2
PE92252V3-0000-A99	●	24	155	3.72	3900	65.0	0.25	42.0	103.0	3
PE92254V1-0000-A99	●	48	125	6.00	4500	75.0	0.35	46.0	103.0	1
PE92254V2-0000-A99	●	48	108	5.19	4200	70.0	0.30	44.0	103.0	2
PE92254V3-0000-A99	●	48	103	4.95	3900	65.0	0.25	42.0	103.0	3

Model		(VDC)	(mA)	(WATTS)	(RPM)	(CFM)	(Inch-H ₂ O)	(dBA)	(g)	Curve
PF92251B1-0000-A99	☉	12	393	4.70	4500	75.0	0.35	47.0	98.0	1
PF92251B2-0000-A99	☉	12	325	3.90	4200	70.0	0.30	45.0	98.0	2
PF92251B3-0000-A99	☉	12	260	3.10	3900	65.0	0.25	43.0	98.0	3
PE92252B1-0000-A99	☉	24	220	5.28	4500	75.0	0.35	47.0	103.0	1
PE92252B2-0000-A99	☉	24	180	4.32	4200	70.0	0.30	45.0	103.0	2
PE92252B3-0000-A99	☉	24	155	3.72	3900	65.0	0.25	43.0	103.0	3
PE92254B1-0000-A99	☉	48	125	6.00	4500	75.0	0.35	47.0	103.0	1
PE92254B2-0000-A99	☉	48	108	5.19	4200	70.0	0.30	45.0	103.0	2
PE92254B3-0000-A99	☉	48	103	4.95	3900	65.0	0.25	43.0	103.0	3

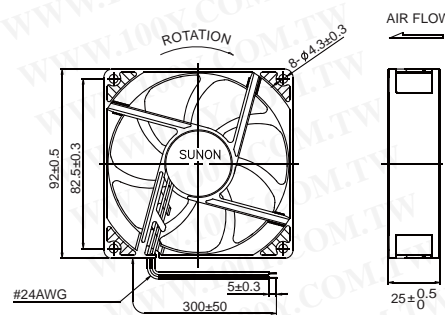
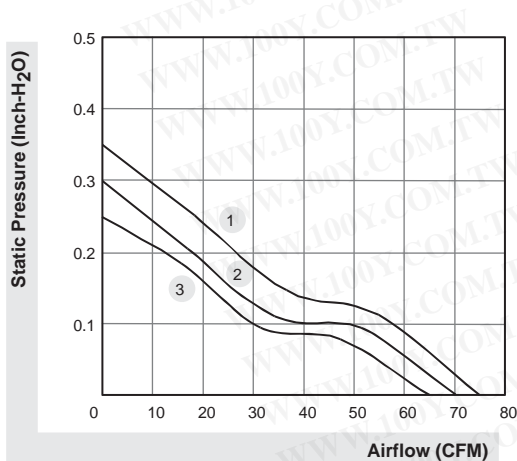

(Units : mm)

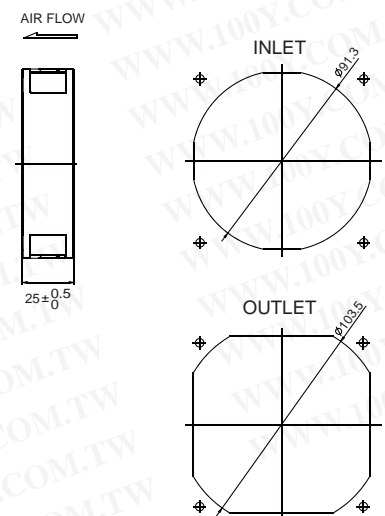

*All model could be customized. Please contact with Sunon Sales.

*Specifications are subject to change without notice. Please Visit SUNON web site at <http://www.sunon.com> for update information.

92x92x25 mm

39.5~55.0 CFM



	Bearing	Rating Voltage (VDC)	Power Current (mA)	Power Consumption (WATTS)	Speed (RPM)	Air Flow (CFM)	Static Pressure (Inch-H ₂ O)	Noise (dBA)	Weight (g)	Curve
	● VAPO									
ME92251VX-0000-A99	●	12	190	2.28	3400	55.0	0.21	37.5	103.0	1
ME92251V1-0000-A99	●	12	165	2.00	3000	51.5	0.15	34.0	96.0	2
ME92251V2-0000-A99	●	12	135	1.60	2700	45.0	0.13	32.0	94.0	3
ME92251V3-0000-A99	●	12	91	1.30	2400	39.5	0.10	28.0	94.0	4
ME92252VX-0000-A99	●	24	100	2.40	3400	55.0	0.21	37.5	103.0	1
ME92252V1-0000-A99	●	24	87	2.10	3000	51.5	0.15	34.0	94.0	2
ME92252V2-0000-A99	●	24	68	1.60	2700	45.0	0.13	32.0	94.0	3
ME92252V3-0000-A99	●	24	56	1.30	2400	39.5	0.10	28.0	94.0	4

Model		(VDC)	(mA)	(WATTS)	(RPM)	(CFM)	(Inch-H ₂ O)	(dBA)	(g)	Curve
EE92251BX-0000-A99	⊙	12	190	2.28	3400	55.0	0.21	37.5	89.0	1
EE92251B1-0000-A99	⊙	12	165	1.98	3000	51.5	0.15	34.0	96.0	2
EE92251B2-0000-999	⊙	12	135	1.60	2700	45.0	0.13	32.0	94.0	3
EE92251B3-0000-999	⊙	12	105	1.30	2400	39.5	0.10	28.0	94.0	4
EE92252BX-0000-A99	⊙	24	100	2.40	3400	55.0	0.21	37.5	97.4	1
EE92252B1-0000-A99	⊙	24	87	2.10	3000	51.5	0.15	34.0	96.0	2
EE92252B2-0000-999	⊙	24	70	1.70	2700	45.0	0.13	32.0	94.0	3
EE92252B3-0000-999	⊙	24	57	1.40	2400	39.5	0.10	28.0	94.0	4
EE92251S1-0000-A99	○	12	165	2.00	3000	51.5	0.15	34.0	94.0	2
EE92251S2-0000-999	○	12	135	1.60	2700	45.0	0.13	32.0	94.0	3
EE92251S3-0000-999	○	12	105	1.30	2400	39.5	0.10	28.0	94.0	4
EE92252S1-0000-A99	○	24	87	2.10	3000	51.5	0.15	34.0	94.0	2
EE92252S2-0000-999	○	24	72	1.70	2700	45.0	0.13	32.0	94.0	3
EE92252S3-0000-999	○	24	60	1.40	2400	39.5	0.10	28.0	94.0	4

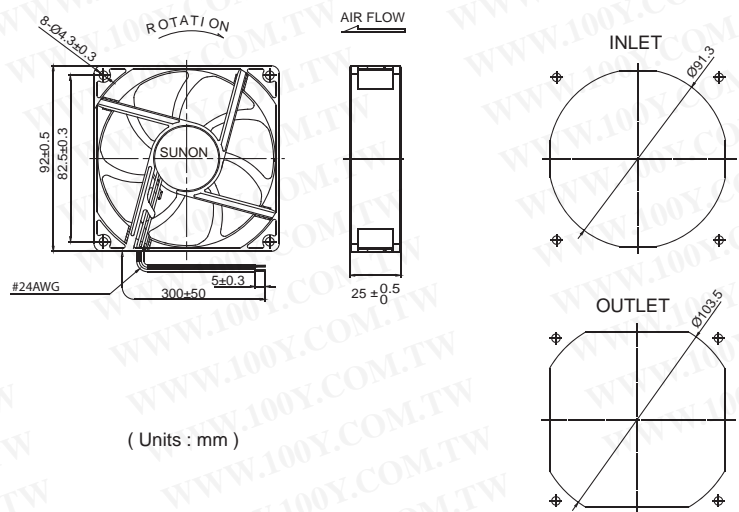
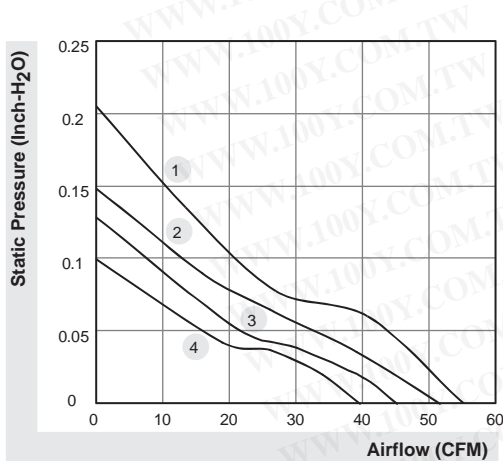

*All model could be customized. Please contact with Sunon Sales.

*Specifications are subject to change without notice. Please Visit SUNON web site at <http://www.sunon.com> for update information.

120x120x25 mm

75.0~108.2 CFM



	Bearing	Rating Voltage	Power Current	Power Consumption	Speed	Air Flow	Static Pressure	Noise	Weight	Curve
	● VAPO	(VDC)	(mA)	(WATTS)	(RPM)	(CFM)	(Inch-H ₂ O)	(dBA)	(g)	
MFC0251V1-0000-A99	●	12	350	4.20	3100	108.2	0.28	44.5	162.0	1
MFC0251V2-0000-A99	●	12	250	3.00	2700	93.0	0.22	40.5	162.0	2
MFC0251V3-0000-A99	●	12	140	1.68	2200	75.0	0.16	34.0	162.0	3
MEC0252V1-0000-A99	●	24	207	5.00	3100	108.2	0.28	44.5	162.0	1
MEC0252V2-0000-A99	●	24	146	3.50	2700	93.0	0.22	40.5	162.0	2
MEC0252V3-0000-A99	●	24	84	2.00	2200	75.0	0.16	34.0	162.0	3
MEC0254V1-0000-A99	●	48	119	5.70	3100	108.2	0.28	44.5	162.0	1
MEC0254V2-0000-A99	●	48	79	3.80	2700	93.0	0.22	40.5	162.0	2
MEC0254V3-0000-A99	●	48	54	2.60	2200	75.0	0.16	34.0	162.0	3

Model		(VDC)	(mA)	(WATTS)	(RPM)	(CFM)	(Inch-H ₂ O)	(dBA)	(g)	Curve
EEC0251B1-0000-A99	☉	12	451	5.4	3100	108.2	0.28	44.5	157.0	1
EEC0251B2-0000-A99	☉	12	279	3.4	2700	93.0	0.22	40.5	157.0	2
EEC0251B3-0000-A99	☉	12	161	1.9	2200	75.0	0.16	34.0	157.0	3
EEC0252B1-0000-A99	☉	24	207	5.0	3100	108.2	0.28	44.5	157.0	1
EEC0252B2-0000-A99	☉	24	146	3.5	2700	93.0	0.22	40.5	157.0	2
EEC0252B3-0000-A99	☉	24	84	2.0	2200	75.0	0.16	34.0	157.0	3
EEC0254B1-0000-A99	☉	48	119	5.7	3100	108.2	0.28	44.5	157.0	1
EEC0254B2-0000-A99	☉	48	79	3.8	2700	93.0	0.22	40.5	157.0	2
EEC0254B3-0000-A99	☉	48	54	2.6	2200	75.0	0.16	34.0	157.0	3

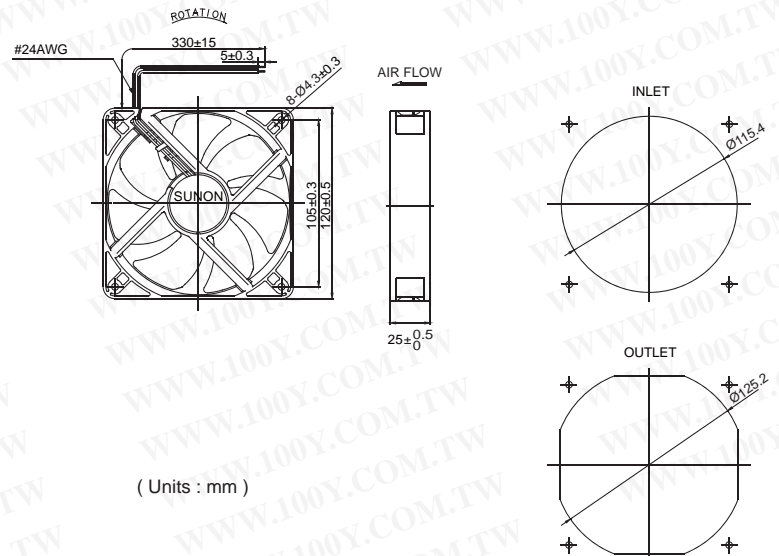
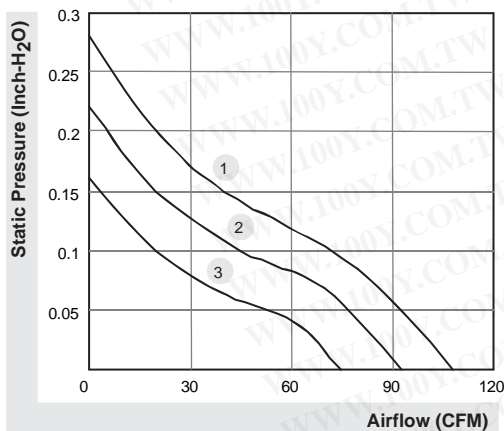

*All model could be customized. Please contact with Sunon Sales.

*Specifications are subject to change without notice. Please Visit SUNON web site at <http://www.sunon.com> for update information.

120x120x38 mm

93.0~138.0 CFM

勝特力材料 886-3-5753170
 勝特力电子(上海) 86-21-34970699
 勝特力电子(深圳) 86-755-83298787
[Http://www.100y.com.tw](http://www.100y.com.tw)



	Bearing	Rating Voltage (VDC)	Power Current (mA)	Power Consumption (WATTS)	Speed (RPM)	Air Flow (CFM)	Static Pressure (Inch-H ₂ O)	Noise (dBA)	Weight (g)	Curve
	● VAPO									
MEC0381V1-0000-A99	●	12	833	10.0	3100	138.0	0.36	48.0	218.0	1
MEC0381V2-0000-A99	●	12	421	5.1	2600	116.0	0.26	44.0	218.0	2
MEC0381V3-0000-A99	●	12	241	2.9	2100	93.0	0.18	37.0	218.0	3
MEC0382V1-0000-A99	●	24	383	9.2	3100	138.0	0.36	48.0	218.0	1
MEC0382V2-0000-A99	●	24	224	5.4	2600	116.0	0.26	44.0	218.0	2
MEC0382V3-0000-A99	●	24	130	3.1	2100	93.0	0.18	37.0	218.0	3
MEC0384V1-0000-A99	●	48	203	9.7	3100	138.0	0.36	48.0	218.0	1
MEC0384V2-0000-A99	●	48	120	5.8	2600	116.0	0.26	44.0	218.0	2
MEC0384V3-0000-A99	●	48	68	3.3	2100	93.0	0.18	37.0	218.0	3

Model		(VDC)	(mA)	(WATTS)	(RPM)	(CFM)	(Inch-H ₂ O)	(dBA)	(g)	Curve
EEC0381B1-0000-A99	☉	12	833	10.0	3100	138.0	0.36	48.0	214.0	1
EEC0381B2-0000-A99	☉	12	421	5.1	2600	116.0	0.26	44.0	214.0	2
EEC0381B3-0000-A99	☉	12	241	2.9	2100	93.0	0.18	37.0	214.0	3
EEC0382B1-0000-A99	☉	24	383	9.2	3100	138.0	0.36	48.0	214.0	1
EEC0382B2-0000-A99	☉	24	224	5.4	2600	116.0	0.26	44.0	214.0	2
EEC0382B3-0000-A99	☉	24	130	3.1	2100	93.0	0.18	37.0	214.0	3
EEC0384B1-0000-A99	☉	48	203	9.7	3100	138.0	0.36	48.0	214.0	1
EEC0384B2-0000-A99	☉	48	120	5.8	2600	116.0	0.26	44.0	214.0	2
EEC0384B3-0000-A99	☉	48	69	3.3	2100	93.0	0.18	37.0	214.0	3

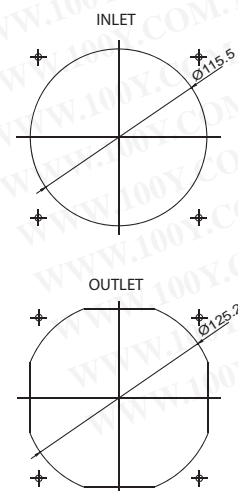
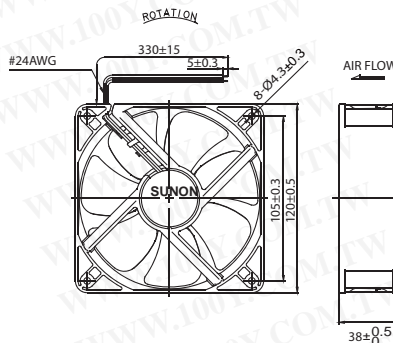
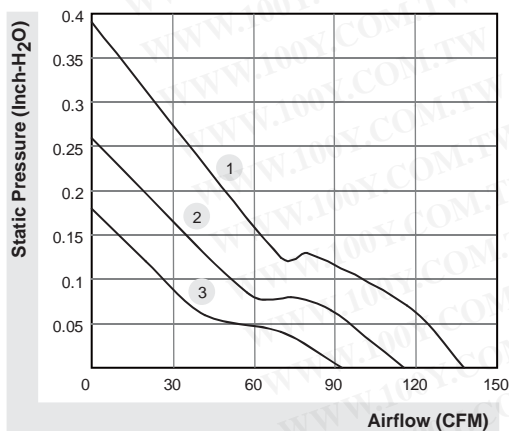

(Units : mm)

*All model could be customized. Please contact with Sunon Sales.

*Specifications are subject to change without notice. Please Visit SUNON web site at <http://www.sunon.com> for update information.