

**SPECIFICATION FOR APPROVAL**

**CUSTOMER** :  
**DESCRIPTION** : AXIAL AC FAN  
**DIMENSIONS** : 180x180x65mm  
**MODEL** : P1189HBT(L)  
**APPROVED NO** :  
(AUTHORIZED)  
**APPROVED BY** :

勝特力材料 886-3-5753170  
勝特力电子(上海) 86-21-34970699  
勝特力电子(深圳) 86-755-83298787  
[Http://www.100y.com.tw](http://www.100y.com.tw)

DAWN.		CHKD.	APPD.		<b>SPEC. NO.</b>	<b>A120424</b>
					<b>ISSUE DATE</b>	<b>5.10.2005</b>
					<b>EDITION</b>	<b>1</b>
					<b>REVISE DATE</b>	<b>5.10.2005</b>
					<b>E.SPEC</b>	<b>EA12058</b>

# AXIAL AC FAN

MODEL : P1189HBT(L)

勝特力材料 886-3-5753170  
勝特力电子(上海) 86-21-34970699  
勝特力电子(深圳) 86-755-83298787  
[Http://www.100y.com.tw](http://www.100y.com.tw)

## CHARACTERISTICS

1. Motor Design : Reliable Alveolate Motor Construction.
2. Insulation Resistance : 500Megohms minimum at 500 VAC.
3. Dielectric Strength : 1800 VAC for one minute.
4. Motor Protection : Thermal protected
5. Noise Level : Measured in a semi-anechoic chamber  
with background noise level below 15  
dB(A). The fan is running in free air with  
microphone at a distance of one meter  
from the fan intake.
6. Air Performance : Measured by a double chamber. The value  
are recorded when the fan speed is stabilized  
at rated voltage.
7. Tolerances :  $\pm 15\%$  on rated power and current.

	SPEC. NO.	P2259MBT	REVISE DATE	5.10. 2005
	ISSUE DATE	5.10 2005	EDITION	1
	PAGE	2 OF 6		

## SPECIFICATIONS

**MODEL: P2189HBT(L)**

- 1-1. Rated Voltage : 110VAC 50/60hz**
- 1-2. Operating Voltage Range : 100-120VAC**
- 1-3. Starting Voltage : 80VAC**
- 1-4. Rated Speed : 2800/3250RPM**
- 1-5. Air Delivery : 355/405 CFM**
- 1-6. Static Pressure : 0.66/0.83 Inch-H<sub>2</sub>O**
- 1-7. Input Power : 51.6/55.5WATTS**
- 1-8 Noise Level : 58/60db(A)**
- 1-9. Direction of Rotation : Counter-clockwise viewed front fan blade**
- 1-10. Motor Protection : Thermal Protected**
- 1-11. Operating Temperature : -10 to +80Deg.C**
- 1-12. Storage Temperature : -30 to +80Deg.C**
- 1-13 Bearing System : ball bearing system**
- 1-14. Weight : 1800g**
- 1-15. Vibration : Vibration of acceleration 2G and Frequency 5~50~5Hz is applied in the 3 directions(X,Y,Z) for 30 minutes, each Direction at the cycle of 1 minute.**
- 1-18 . Life Expectancy : 60000Hrs at 25°C**

	<b>SPEC. NO.</b>	<b>1</b>	<b>REVISE DATE</b>	<b>5. 10. 2005</b>
	<b>ISSUE DATE</b>	<b>5.10. 2005</b>	<b>EDITION</b>	<b>1</b>
	<b>PAGE</b>	<b>3 OF 6</b>		

# MODEL : P2189HBT(L)

## PERFORMANCE CURVES

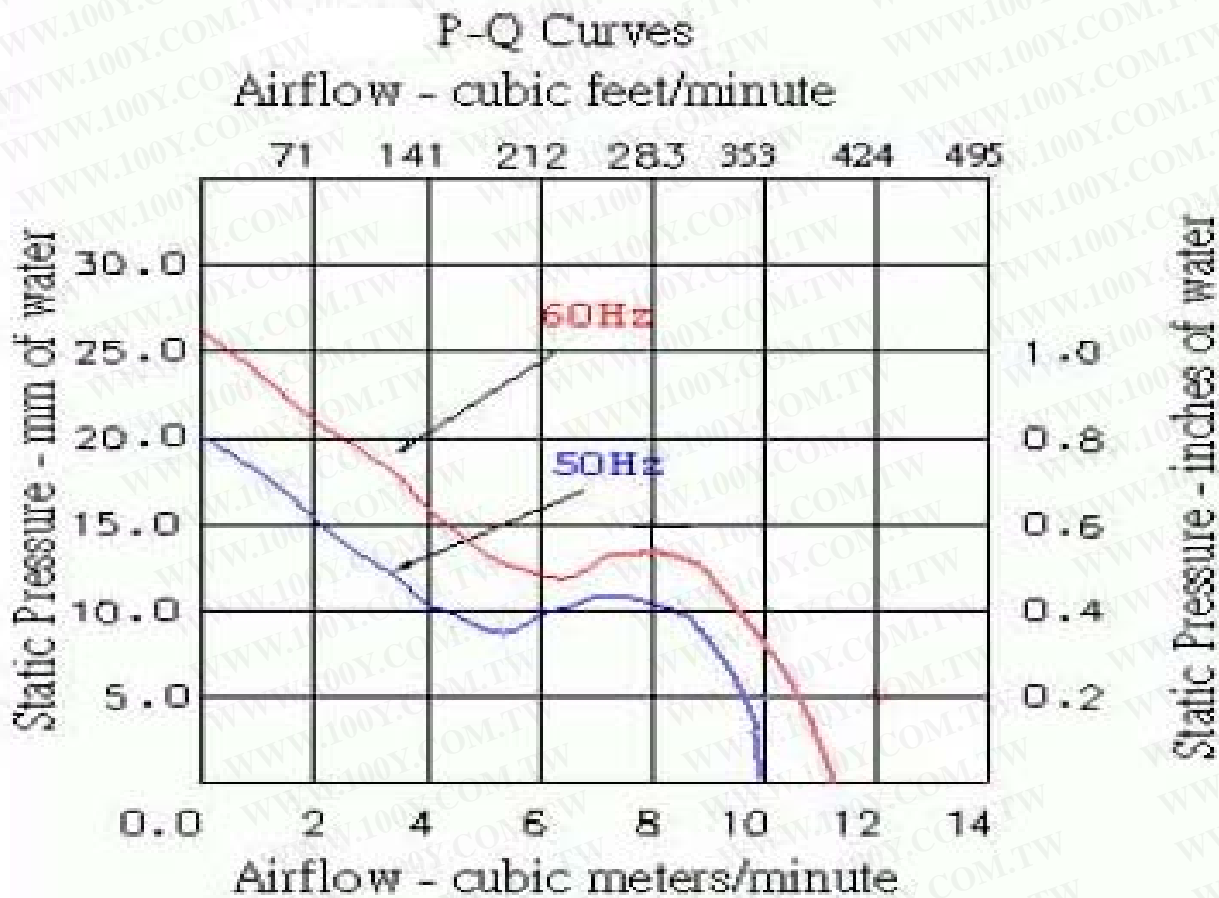

勝特力材料 886-3-5753170  
 勝特力电子(上海) 86-21-34970699  
 勝特力电子(深圳) 86-755-83298787  
[Http://www.100y.com.tw](http://www.100y.com.tw)

	SPEC. NO.	1	REVISE DATE	5. 10. 2005
	ISSUE DATE	5.10.2005	EDITION	1
	PAGE	4 OF 6		

## MATERIAL

### 2. Material

2-1. Frame : DIE-CAST ALUMINUM

2-2. Impeller : Thermoplastic PBT of UL 94V-0

## DIMENSIONS

勝特力材料 886-3-5753170  
 勝特力电子(上海) 86-21-34970699  
 勝特力电子(深圳) 86-755-83298787  
[Http://www.100y.com.tw](http://www.100y.com.tw)

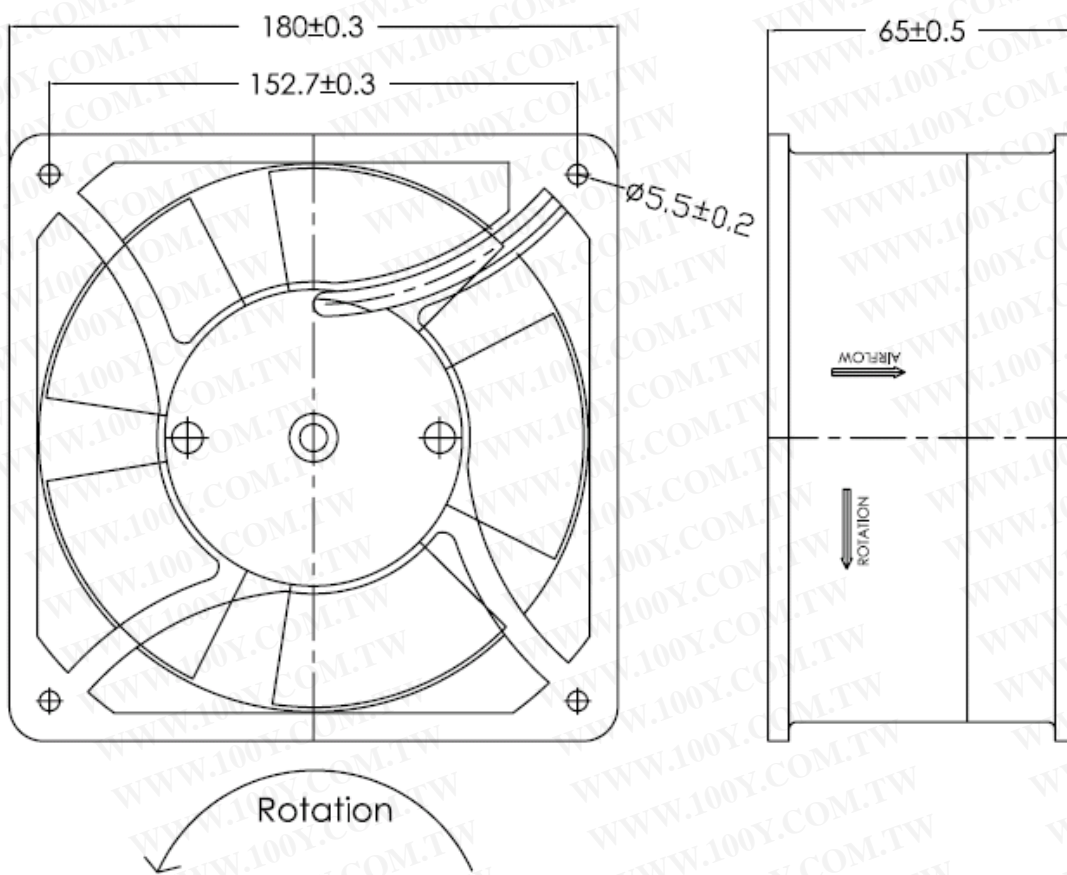

**Air Flow Direction: Label side.**

**UNITS : mm**

	<b>SPEC. NO.</b>	<b>1</b>	<b>REVISE DATE</b>	<b>5. 10. 2005</b>
	<b>ISSUE DATE</b>	<b>5.10. 2005</b>	<b>EDITION</b>	<b>1</b>
	<b>PAGE</b>	<b>5 OF 6</b>		

# Notes

1. Profantec eguarantee the products if the application conditions exceed those set out in this specification.
2. A written request should be submitted to Profantec acceptance if deviation from this specification is required.
3. Caution should be exercised when handling the fan. Damages may be resulted when apply pressure to the impeller or hold the fan by the lead wires.
4. No guarantee on the products against the safety problem or failure caused by powder dust, drop of water or insect.
5. This specification sheet precedes all other information and should be used as the principal reference for the product to which it refers.
6. To satisfy the Profantec anagement Information System, please indicate SPEC. NO. on every order.
7. It is important that the correct polarity is established before connecting the fan to the electrical supply. Black (0V) , Red(+V). If cautions is not taken, immediate damage may occur on fans that do not have polarity protection.
8. fans are not suitable to be used in an environment that contains aggressive or corrosive fluids.
9. Always ensure that fans are stored according to the storage temperatures specified. Do not store in an environment with a high humidity level. If the fans were stored for longer than 6 months, it is highly recommended to apply functional testing before shipping.
10. Not all fans incorporate the Lock Rotor Protection feature. For fans that do not incorporate this feature it is important not to prevent the rotation of the impeller. Doing so, will lead to failure.
11. During installation, caution should be taken when mounting the fan. Incorrect mounting can cause excess resonance, vibration and noise.
12. During testing it is important to consider safety at all times. A suitable guard should be fitted to the fan to prevent personal injury.
13. Unless otherwise stated, all tests are carried out at relative temperature and humidity conditions of 25°C, 65%.

	SPEC.NO		REVISE DATE	5. 10. 2005
	ISSUE DATE	5.10.2005	EDITION	1
	PAGE	6 OF 6		