

REVISION RECORD				
REV	ECO	DESCRIPTION	DRFT	CHKD

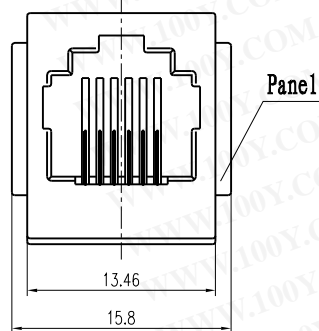

勝特力材料 886-3-5753170
 勝特力电子(上海) 86-21-34970699
 勝特力电子(深圳) 86-755-83298787
 Http://www.100y.com.tw

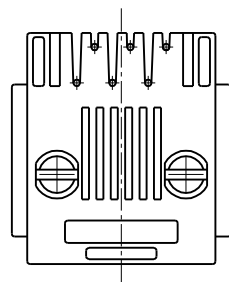
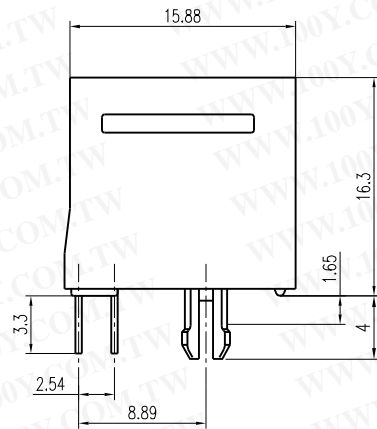
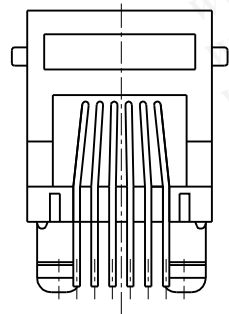

PCB LAYOUT

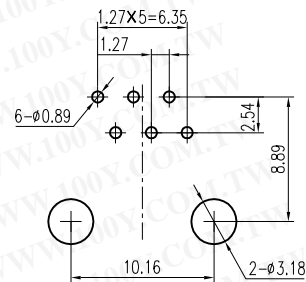

NOTES:

ELECTRICAL:

- 1. VOLTAGE RATING :125 VAC RMS.
- 2. CURRENT RATING :1.5 AMP.
- 3. CONTACT RESISTANCE :30 MILLIOHMS MAX.
- 4. INSULATION RESISTANCE :500 MEGOHMS MIN @ 500V DC .
- 5. DIELECTRIC STRENGTH :1000V AC RMS 50Hz. 1MIN.

MECHANICAL:

- 1. HOUSING MATERIAL :GLASS FILLED POLYESTER UL94V-0.
- 2. CONTACT MATERIAL :PHOSPHOR BRONZE ø0.46mm.
- 3. PLATING :GOLD PLATING OVER NICKEL.
- 4. OPERATING :750 CYCLES MIN.
- 5. PCB RETENTION PRE-SOLDER :1 LB MIN.

ENVIRONMENTAL:

- 1. Temperature Range : -45℃~+85℃
- 2. Relative Humidity : 90~95% (40±2℃)

PART NUMBER:

DY 154 -
 3u" 6u" 15u" 30u" 50u" PD20u"
 L(L Peg) S(Splig Peg)
 W(With Panel) W/O(Without Panel)
 6P2C 6P4C 6P6C
 Part No.

DETACHED LISTS	mm (inch)		DFTO:	DATE:	DY 154-S
	Tolerance Except as Noted		CHKD:	DATE:	
	mm	±	MFO:	DATE:	
	0±0.2	±	APPL:	DATE:	
	00±0.15	±	MATERIAL:		
	000±0.075	±	Q' TY:		
	ANGLES ± 0.5		DRAWING NO.		
		FINISH:		A4	
SCALE: 2:1		/PART NO.		REV 06/06/02 0	
DO NOT SCALE DRAWING				SHEET OF	