

PC123XxxFZ0F Series Photocoupler

Product Specification

August 2006

PC123XxxFZ0F Series

Full Specification for part numbers:

PC123XNNFZ0F

PC123XNYFZ0F

PC123XINFZ0F

PC123XIYFZ0F

PC123X2NFZ0F

PC123X2YFZ0F

PC123X5NFZ0F

PC123X51FZ0F

PC123X8NFZ0F

PC123X8YFZ0F

PC123X9NFZ0F

PC123X9YFZ0F

勝特力材料 886-3-5753170

勝特力电子(上海) 86-21-34970699

勝特力电子(深圳) 86-755-83298787

[Http://www.100y.com.tw](http://www.100y.com.tw)



SHARP

OPTO-ANALOG DEVICES DIVISION
ELECTRONIC COMPONENTS GROUP
SHARP CORPORATION

SPECIFICATION

DEVICE SPECIFICATION FOR
PHOTOCOUPLER
MODEL No. PC123

Business dealing name

PC123XNNFZ0F	PC123XNYFZ0F
PC123X1NFZ0F	PC123X1YFZ0F
PC123X2NFZ0F	PC123X2YFZ0F
PC123X5NFZ0F	PC123X5YFZ0F
PC123X8NFZ0F	PC123X8YFZ0F
PC123X9NFZ0F	PC123X9YFZ0F

Specified for

Enclosed please find copies of the Specifications which consists of 14 pages including cover.
This specification sheets and attached sheets shall be both side copy.
After confirmation of the contents, please be sure to send back copies of the Specifications
with approving signature on each.

CUSTOMER'S APPROVAL

PRESENTED

DATE

DATE *Aug. 29, 2006*

BY

BY *H. Inanaka*

勝特力材料 886-3-5753170
勝特力电子(上海) 86-21-34970699
勝特力电子(深圳) 86-755-83298787
[Http://www.100y.com.tw](http://www.100y.com.tw)

H. Inanaka,
Department General Manager of
Engineering Dept., II
Opto-Analog Devices Div.
ELECOM Group
SHARP CORPORATION

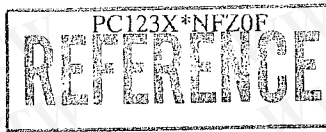

Product name : PHOTOCOUPLER

Model No. : PC123

Business dealing name

勝特力材料 886-3-5753170
勝特力电子(上海) 86-21-34970699
勝特力电子(深圳) 86-755-83298787
Http://www.100y.com.tw

Table with 2 columns and 6 rows listing various PC123X models like PC123X1NFZ0F, PC123X1YFZ0F, etc.

- 1. These specification sheets include materials protected under copyright of Sharp Corporation ("Sharp"). Please do not reproduce or cause anyone to reproduce them without Sharp's consent.
2. When using this product, please observe the absolute maximum ratings and the instructions for use outlined in these specification sheets, as well as the precautions mentioned below. Sharp assumes no responsibility for any damage resulting from use of the product which does not comply with the absolute maximum ratings and the instructions included in these specification sheets, and the precautions mentioned below.
(Precautions)
(1) This product is designed for use in the following application areas ;
(2) Appropriate measures, such as fail-safe design and redundant design considering the safety design of the overall system and equipment, should be taken to ensure reliability and safety when this product is used for equipment which demands high reliability and safety in function and precision, such as ;
(3) Please do not use this product for equipment which require extremely high reliability and safety in function and precision, such as ;
(4) Please contact and consult with a Sharp sales representative if there are any questions regarding interpretation of the above three paragraphs.
3. Please contact and consult with a Sharp sales representative for any questions about this product.

PC123X*NFZ0F REFERENCE

1. Application
This specification applies to the outline and characteristics of photocoupler Model No. PC123(Lead-Free Type).
2. Outline Refer to the attached sheet, page 3.
3. Ratings and characteristics Refer to the attached sheet, page 4, 5.
4. Reliability Refer to the attached sheet, page 6.
5. Outgoing inspection Refer to the attached sheet, page 7.
6. Supplement

6.1 Isolation voltage shall be measured in the following method.

- (1) Short between anode and cathode on the primary side and between collector and emitter on the secondary side.
- (2) The dielectric withstanding tester with zero-cross circuit shall be used.
- (3) The wave form of applied voltage shall be a sine wave.
(It is recommended that the isolation voltage be measured in insulation oil.)

6.2 Packing specifications Refer to the attached sheet, page 8, 9.

6.3 Collector current (Ic) Delivery rank table ("O" mark indicates business dealing name of ordered product)

Rank at delivery	Business dealing name	Rank at delivery	* Business dealing name	Rank mark	Ic (mA)	Test conditions
	PC123XNNFZ0F		PC123XNYFZ0F	with or without	2.5 to 20.0	I _F =5mA V _{CE} =5V Ta=25°C
	PC123X1NFZ0F		PC123X1YFZ0F	L	2.5 to 7.5	
	PC123X2NFZ0F		PC123X2YFZ0F	M	5.0 to 12.5	
	PC123X5NFZ0F		PC123X5YFZ0F	N	10.0 to 20.0	
	PC123X8NFZ0F		PC123X8YFZ0F	E	5.0 to 10.0	
	PC123X9NFZ0F		PC123X9YFZ0F	C	8.0 to 15.0	

*Applied to products as option (Attachment 2-1 to 2-3)

6.4 This Model is approved by UL.

Approved Model No. : PC123

UL file No. : E64380

6.5 This Model is approved by CSA.

Approved Model No. : PC123

CSA file No. : CA95323

CSA approved mark "  " shall be indicated on minimum unit package.

6.6 This product is approved by BSI. (BS EN60065, BS EN60950)

Approved Model No. : PC123

Certificate No. : 7087/7409

6.7 This product is approved by SEMKO, DEMKO, NEMKO and FIMKO.

6.8 This product is not designed against irradiation.

This product is assembled with electrical input and output.

This product incorporates non-coherent light emitting diode.

6.9 ODS materials

This product shall not contain the following materials.

Also, the following materials shall not be used in the production process for this product.

Materials for ODS : CFCs, Halon, Carbon tetrachloride, 1,1,1-Trichloroethane (Methyl chloroform)

6.10 Specified brominated flame retardants

Specified brominated flame retardants (PBB and PBDE) are not used in this device at all

7. Notes

Precautions for photocouplers : Attachment-1

勝特力材料 886-3-5753170
勝特力电子(上海) 86-21-34970699
勝特力电子(深圳) 86-755-83298787
Http://www.100y.com.tw

PC123X*NFZ0F
REFERENCE

2. Outline

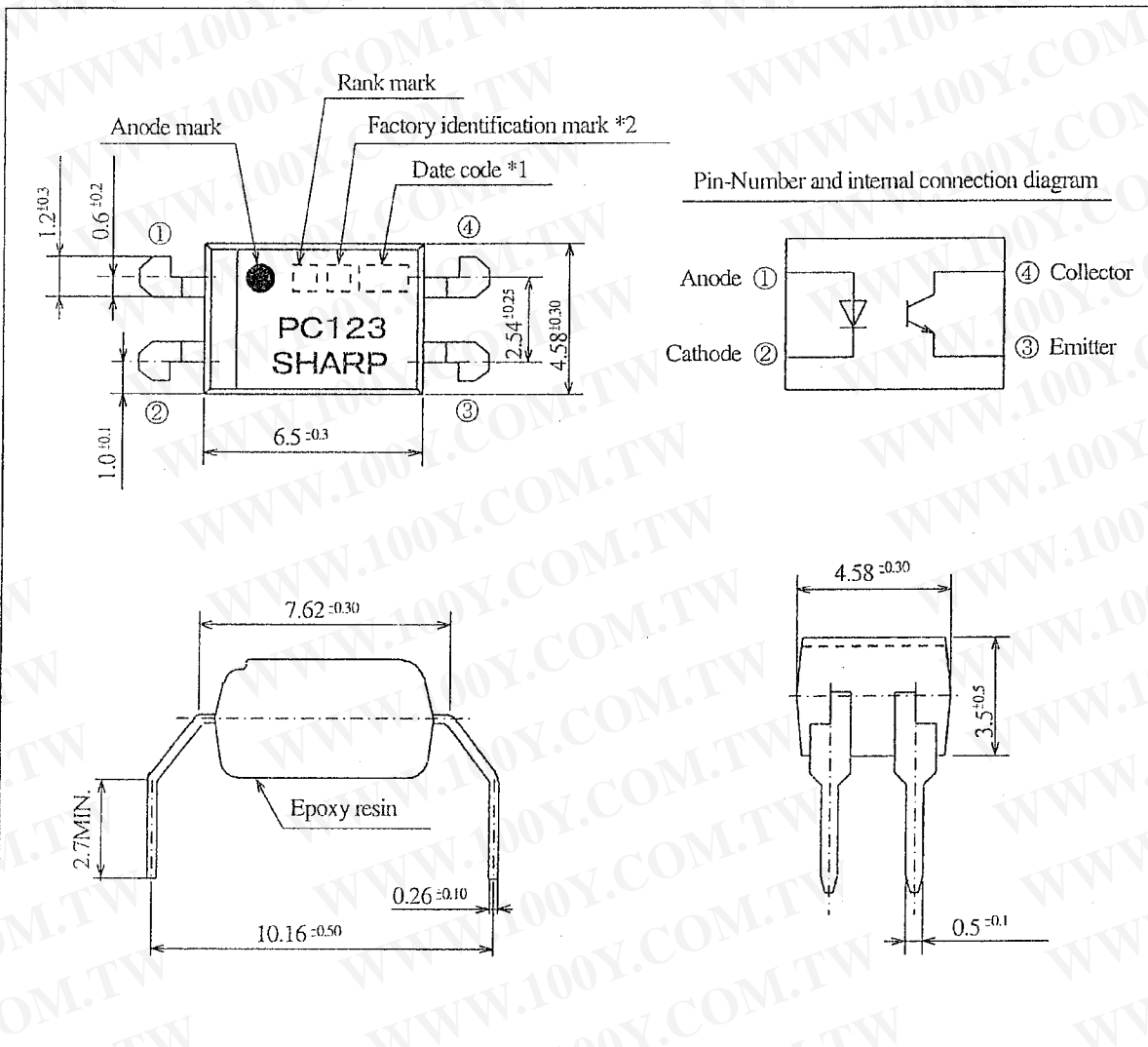

Pin-Number and internal connection diagram

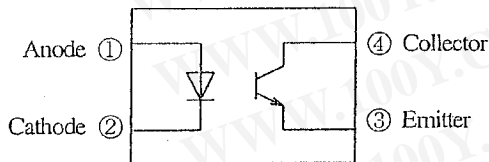

*1) 2-digit number shall be marked according to OLD DIN standard.

*2) Factory identification mark shall be or shall not be marked.

Without : SUN-S Corporation (Japan)

△ : WUXI WONDERFUL ELECTRONICS CO. LTD. (CHINA)

Pin material : Copper Alloy

Pin finish : SnCu plating (Cu : TYP. 2%)

勝特力材料 886-3-5753170
 勝特力电子(上海) 86-21-34970699
 勝特力电子(深圳) 86-755-83298787
[Http://www.100y.com.tw](http://www.100y.com.tw)

Product mass : Approx. 0.23 g

UNIT : 1/1 mm

Marking is laser marking

Name	PC123 Outline Dimensions (Business dealing name : PC123X*NFZ0F)
------	--

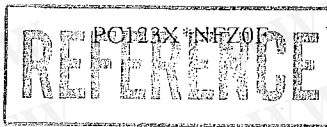

3. Ratings and characteristics

3.1 Absolute maximum ratings

Ta=25°C

Parameter		Symbol	Rating	Unit
Input	Forward current *1	I_F	50	mA
	Peak forward current *2	I_{FM}	1	A
	Reverse voltage	V_R	6	V
	Power dissipation *1	P	70	mW
Output	Collector-emitter voltage	V_{CEO}	70	V
	Emitter-collector voltage	V_{ECO}	6	V
	Collector current	I_c	50	mA
	Collector power dissipation *1	P_c	150	mW
Total power dissipation *1		P_{tot}	200	mW
Operating temperature		T_{opr}	-30 to +100	°C
Storage temperature		T_{stg}	-55 to +125	°C
Isolation voltage *3		$V_{iso (ms)}$	5	kV
Soldering temperature *4		T_{sol}	270	°C

3.2 Electro-optical characteristics

Ta=25°C

Parameter		Symbol	Condition	MIN.	TYP.	MAX.	Unit
Input	Forward voltage	V_F	$I_F=20mA$	-	1.2	1.4	V
	Reverse current	I_R	$V_R=4V$	-	-	10	μA
	Terminal capacitance	C_T	$V=0, f=1kHz$	-	30	250	pF
Output	Dark current	I_{CEO}	$V_{CE}=50V, I_F=0$	-	-	100	nA
	Collector-emitter breakdown voltage	BV_{CEO}	$I_c=0.1mA, I_F=0$	70	-	-	V
	Emitter-Collector breakdown voltage	BV_{ECO}	$I_E=10\mu A, I_F=0$	6	-	-	V
Transfer characteristics	Collector current	I_c	$I_F=5mA, V_{CE}=5V$	2.5	-	20	mA
	Collector-emitter saturation voltage	$V_{CE(sat)}$	$I_F=20mA, I_c=1mA$	-	0.1	0.2	V
	Isolation resistance	R_{ISO}	DC500V 40 to 60%RH	5×10^{10}	10^{11}	-	Ω
	Floating capacitance	C_f	$V=0, f=1MHz$	-	0.6	1.0	pF
	Cut-off frequency	f_c	$V_{CE}=5V, I_c=2mA$ $R_L=100\Omega, -3dB$	-	80	-	kHz
	Response time (Rise)	t_r	$V_{CE}=2V, I_c=2mA$	-	4	18	μs
	Response time (Fall)	t_f	$R_L=100\Omega$	-	3	18	μs

*1 The derating factors of absolute maximum ratings due to ambient temperature are shown in Fig. 1 to 4.

*2 Pulse width $\leq 100 \mu s$, Duty ratio : 0.001 (Refer to Fig. 5)

*3 AC for 1 min, 40 to 60%RH

*4 For 10s

勝特力材料 886-3-5753170
 勝特力电子(上海) 86-21-34970699
 勝特力电子(深圳) 86-755-83298787
[Http://www.100y.com.tw](http://www.100y.com.tw)

(Fig.1) Forward current vs. ambient temperature

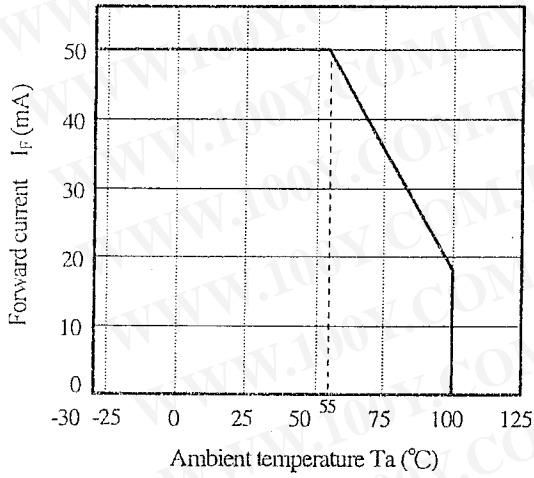

(Fig.2) Diode power dissipation vs. ambient temperature

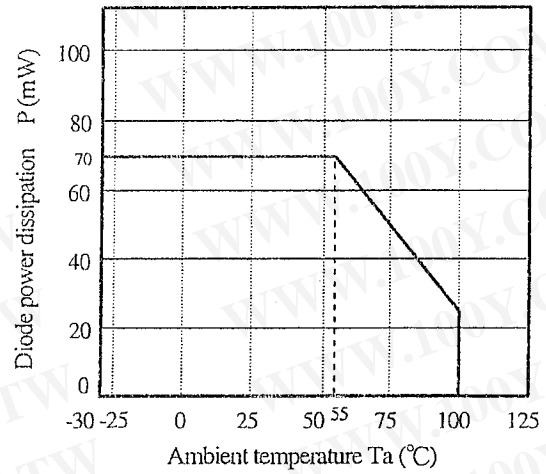

(Fig.3) Collector power dissipation vs. ambient temperature

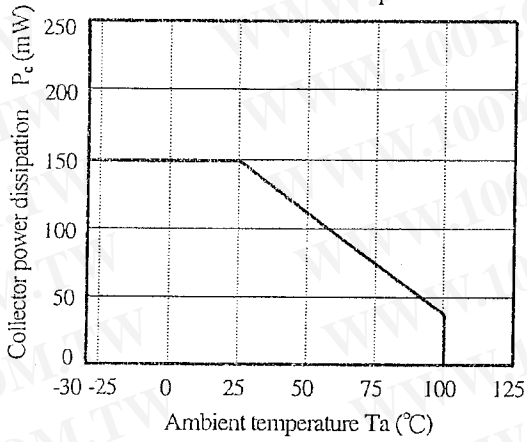

(Fig.4) Total power dissipation vs. ambient temperature

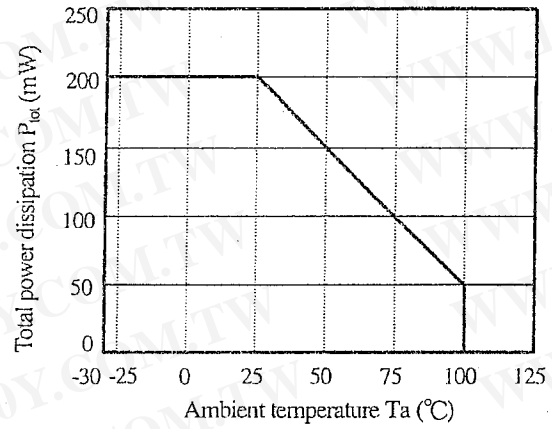

(Fig.5) Forward current vs. duty ratio
 Pulse width $\leq 100\mu s$
 $T_a = 25^\circ C$

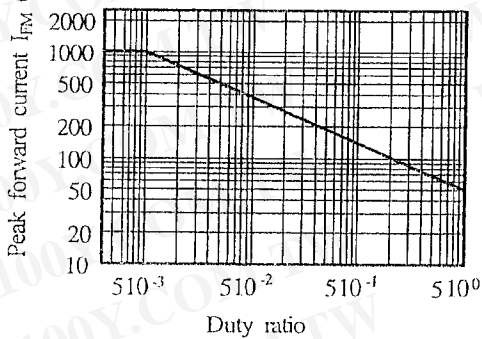

勝特力材料 886-3-5753170
勝特力电子(上海) 86-21-34970699
勝特力电子(深圳) 86-755-83298787
[Http://www.100y.com.tw](http://www.100y.com.tw)

PG123X*NFZ0F
REFERENCE

4. Reliability

The reliability of products shall satisfy items listed below.

Confidence level : 90%

LTPD : 10 or 20

Test Items	Condition	Failure Judgment Criteria	Samples (n) Defective (C)
Solderability *2	245±3°C, 5s	-	n=11, C=0
Soldering heat	(Flow soldering) 270°C, 10 s	$V_F > U \times 1.2$ $I_R > U \times 2$ $I_{CBO} > U \times 2$ $I_C < L \times 0.7$ $V_{CE(sat)} > U \times 1.2$ U: Upper specification limit L: Lower specification limit	n=11, C=0
	(Soldering by hand) 400°C, 3 s		n=11, C=0
Terminal strength (Tension)	Weight: 5N 5 s/each terminal		n=11, C=0
Terminal strength (Bending) *3	Weight: 2.5N 2 times/each terminal		n=11, C=0
Mechanical shock	15km/s ² , 0.5ms 3 times/±X, ±Y, ±Z direction		n=11, C=0
Variable frequency vibration	100 to 2000 to 100Hz/4 min 200m/s ² 4 times/X, Y, Z direction		n=11, C=0
Temperature cycling	1 cycle -55 °C to +125 °C (30 min) (30 min) 20 cycles test		n=22, C=0
High temp. and high Humidity storage	+85°C, 85%RH, 1000h		n=22, C=0
High temp. storage	+125 °C, 1000h		n=22, C=0
Low temp. storage	-55 °C, 1000h		n=22, C=0
Operation life	$I_F=50mA$, $P_{tot}=200mW$ $T_a=25 °C$, 1000h	n=22, C=0	

*1 Test method, conforms to EIAJ ED 4701.

*2 Solder shall adhere at the area of 95% or more of immersed portion of lead, and pin hole or other holes shall not be concentrated on one portion.

*3 Terminal bending direction is shown below.

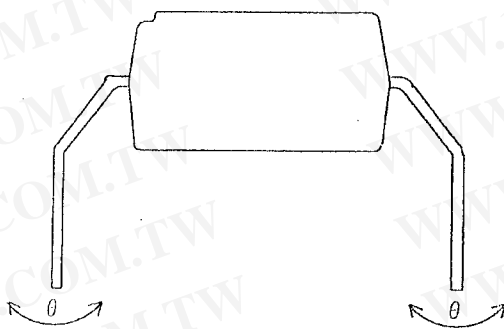

勝特力材料 886-3-5753170
 勝特力电子(上海) 86-21-34970699
 勝特力电子(深圳) 86-755-83298787
[Http://www.100y.com.tw](http://www.100y.com.tw)



5. Outgoing inspection

5.1 Inspection items

- (1) Electrical characteristics

$V_F, I_R, I_{CEO}, V_{CE(sat)}, I_c, R_{ISO}, V_{iso}$

- (2) Appearance

5.2 Sampling method and Inspection level

A single sampling plan, normal inspection level II based on ISO 2859 is applied.

The AQL according to the inspection items are shown below.

Defect	Inspection item	AQL (%)
Major defect	Electrical characteristics Unreadable marking	0.065
Minor defect	Appearance defect except the above mentioned.	0.25

勝特力材料 886-3-5753170
 勝特力电子(上海) 86-21-34970699
 勝特力电子(深圳) 86-755-83298787
[Http://www.100y.com.tw](http://www.100y.com.tw)



6.2 Packing specification

6.2.1 Package materials

No.	Name	Materials	Purposes
①	Sleeve	HIPS with preventing static electricity	Products packaged
②	Stopper	Styrene-Erastomer	Products fixed
③	Packing case	Corrugated cardboard	Sleeve packaged
④	Molt plane	Urethane	Sleeve fixed
⑤	Kraft tape	Paper	Lid of packing case fixed
⑥	Label	Paper	Model No.,(Business dealing name),Lot No., Quantity, country of origin , Company name and inspection date specified

6.2.2 Package method

- (1) MAX. 100pcs. of products shall be packaged in a sleeve ① and both of sleeve edges shall be fixed by stoppers ②.
- (2) MAX. 20 sleeves (product : 2000pcs.) above shall be packaged in a packing case ③ and pack a sheet of Moltplane ④ at one side.
- (3) The label ⑥ shall be put on the side of the packing case.
- (4) Case shall be closed with the lid and enclosed with kraft tape ⑤.

6.2.3 Sleeve package ① outline dimensions

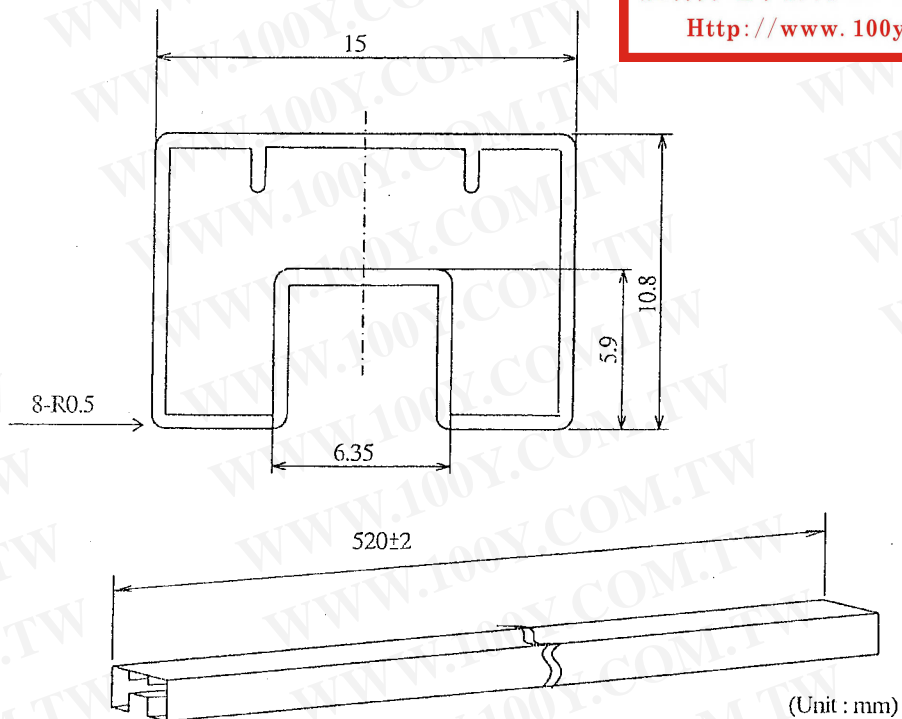

- Note
- 1) Thickness : $0.5 \pm 0.2\text{mm}$
 - 2) Process with applying antistatic agent.
 - 3) Unless otherwise specified tolerances shall be $\pm 0.5\text{mm}$.
(However except for deformation due to the stopper in sleeve.)

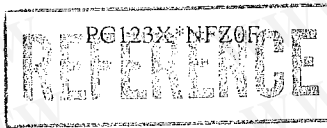

6.2.4 Packing case outline dimensions

勝特力材料 886-3-5753170
勝特力电子(上海) 86-21-34970699
勝特力电子(深圳) 86-755-83298787
Http://www.100y.com.tw

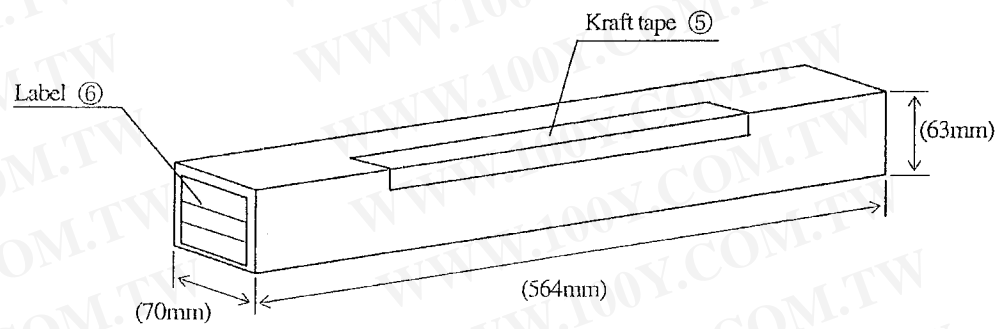
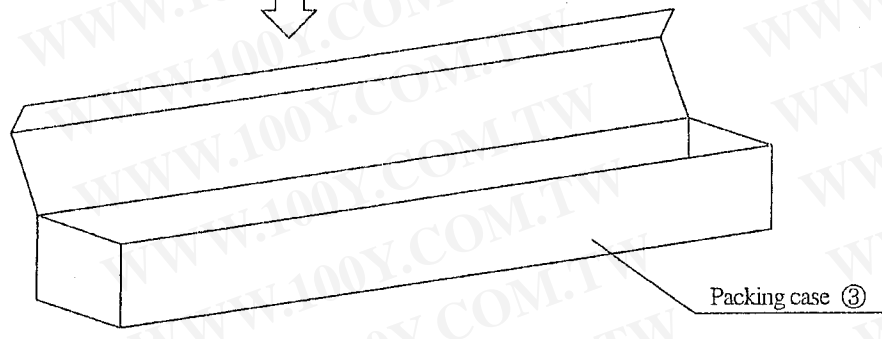
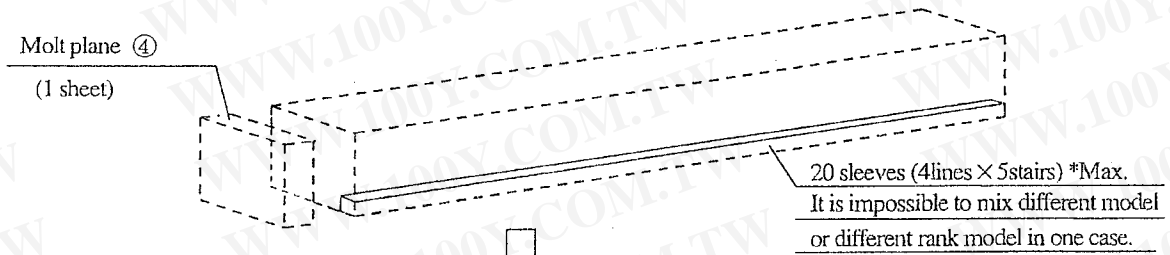
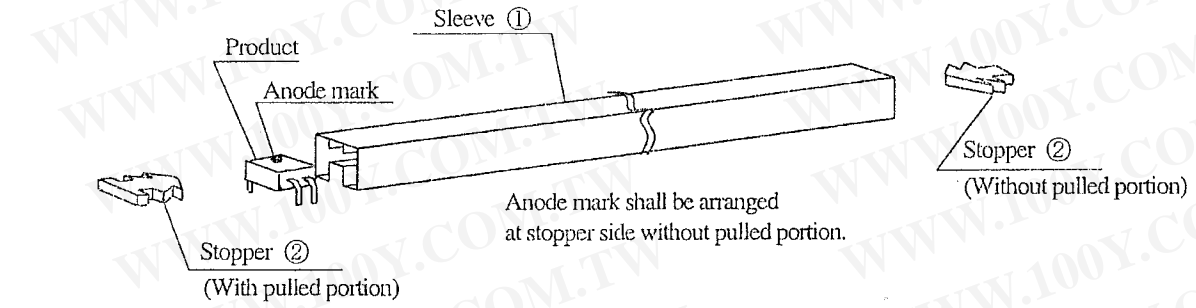

Regular packing mass : Approx. 910g
() : Reference dimensions

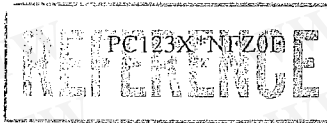

Precautions for Photocouplers

勝特力材料 886-3-5753170
勝特力电子(上海) 86-21-34970699
勝特力电子(深圳) 86-755-83298787
[Http://www.100y.com.tw](http://www.100y.com.tw)

1. Cleaning

- (1) Solvent cleaning : Solvent temperature 45°C or less
Immersion for 3 min or less
- (2) Ultrasonic cleaning : The effect to device by ultrasonic cleaning differs by cleaning bath size, ultrasonic power output, cleaning time, PCB size or device mounting condition etc. Please test it in actual using condition and confirm that any defect doesn't occur before starting the ultrasonic cleaning.
- (3) Applicable solvent : Ethyl alcohol, Methyl alcohol, Isopropyl alcohol
When the other solvent is used, there are cases that the packaging resin is eroded.
Please use the other solvent after thorough confirmation is performed in actual using condition.

2. Circuit design

- 2.1 The LED used in the Photocoupler generally decreases the light emission power by operation.
In case of long operation time, please design the circuit in consideration of the degradation of the light emission power of the LED. (50%/5years)
- 2.2 There are cases that the deviation of the CTR and the degradation of the relative light emission power of the LED increase when the setting value of $I_f < 1\text{mA}$. Please design the circuit in consideration of this point.

3. Precautions for Soldering

- (1) In the case of flow soldering (Whole dipping is possible)
It is recommended that flow soldering should be at 270°C or less for 10 s or less
(Pre-heating : 100 to 150°C, 30 to 80s). (2 times or less)
- (2) In the case of hand soldering
What is done on the following condition is recommended. (2 times or less)
Soldering iron temperature : 400°C or less
Time : 3s or less
- (3) Other precautions
Depending on equipment and soldering conditions (temperature, Using solder etc.),
the effect to the device and the PCB is different.
Please confirm that there is no problem on the actual use conditions in advance.

PC123X*YFZ0F
REFERENCE

勝 特 力 材 料 886-3-5753170
勝 特 力 電 子 (上 海) 86-21-34970699
勝 特 力 電 子 (深 圳) 86-755-83298787
Http://www.100y.com.tw

1. This specification shall be applied to photocoupler, Model No. PC123 as an option.
2. Applicable Models (Business dealing name)
PC123XNYFZ0F, PC123X1YFZ0F, PC123X2YFZ0F, PC123X5YFZ0F, PC123X8YFZ0F, PC123X9YFZ0F
3. The relevant models are the models approved by VDE according to DIN EN 60747-5-2.
Up to date code "RD" (December 2003), the relevant models are approved by VDE according to DIN VDE 0884/08.87.
Approved Model No. : PC123
VDE approved No. : 40008087 (According to the specification DIN EN 60747-5-2)

- Operating isolation voltage U_{IORM} : 1140V (Peak)
- Transient voltage : 9000V (Peak)
- Pollution : 2
- Clearances distance (Between input and output) : 8.0mm (MIN.)
- Creep age distance (Between input and output) : 8.0mm (MIN.)
- Isolation thickness between input and output : 0.4mm (MIN.)
- Tracking-proof : CTI 175
- Safety limit values
 - Current (Isi) : 200mA (Diode side)
 - Power (Psi) : 300mW (Phototransistor side)
 - Temperature (Tsi) : 150°C

In order to keep safety electric isolation of photocoupler, please set the protective circuit to keep within safety limit values when the actual application equipment troubled.

- Indication of VDE approval "  " is printed on minimum unit package.

4. Outline Refer to the attachment-2-2.

5. Isolation specification according to EN 60747-5-2

Parameter	Symbol	Condition	Rating	Unit	Remark									
Class of environmental test	-	-	55/110/21	-										
Pollution	-	-	2	-										
Maximum operating isolation voltage	U_{IORM} (PEAK)	-	1140	V	Refer to the Diagram 1, 2 (Attachement-2-3)									
Partial discharge test voltage (Between input and output)														
<table border="1" style="width: 100%;"> <tr> <td>Diagram 1</td> <td>U_{PR} (PEAK)</td> <td>$t_p=10s, q_c<5pC$</td> <td>1710</td> <td>V</td> </tr> <tr> <td>Diagram 2</td> <td></td> <td>$t_p=1s, q_c<5pC$</td> <td>2140</td> <td>V</td> </tr> </table>	Diagram 1	U_{PR} (PEAK)	$t_p=10s, q_c<5pC$	1710		V	Diagram 2		$t_p=1s, q_c<5pC$	2140	V			
Diagram 1	U_{PR} (PEAK)	$t_p=10s, q_c<5pC$	1710	V										
Diagram 2		$t_p=1s, q_c<5pC$	2140	V										
Maximum over-voltage	U_{IOTM} (PEAK)	$t_{INI}=60s$	9000	V										
Safety maximum ratings					Refer to the Fig. 6, 7 (Attachement-2-3)									
1) Case temperature	Tsi	$I_f=0, P_C=0$	150	°C										
2) Input current	Isi	$P_C=0$	200	mA										
3) Electric power (Output or Total power dissipation)	Psi	-	300	mW										
Isolation resistance (Test voltage between input and output ; DC500V)	R_{ISO}	<table border="1" style="width: 100%;"> <tr> <td>$T_a=T_{si}$</td> <td>$MIN.10^9$</td> </tr> <tr> <td>$T_a=T_{opr} (MAX.)$</td> <td>$MIN.10^{11}$</td> </tr> <tr> <td>$T_a=25°C$</td> <td>$MIN.10^{12}$</td> </tr> </table>	$T_a=T_{si}$	$MIN.10^9$	$T_a=T_{opr} (MAX.)$	$MIN.10^{11}$	$T_a=25°C$	$MIN.10^{12}$		Ω				
$T_a=T_{si}$	$MIN.10^9$													
$T_a=T_{opr} (MAX.)$	$MIN.10^{11}$													
$T_a=25°C$	$MIN.10^{12}$													

6. Precautions in performing isolation test

6.1 Partial discharge test methods shall be the ones according to the specifications of EN 60747-5-2

6.2 Please don't carry out isolation test (V_{RO}) over U_{IOTM} .

This product deteriorates isolation characteristics by partial discharge due to applying high voltage (ex. U_{IOTM}).

And there is possibility that partial discharge occurs in operating isolation voltage. (U_{IORM}).

PC123X*YFZ0F
REFERENCE

4. Outline

勝特力材料 886-3-5753170
勝特力电子(上海) 86-21-34970699
勝特力电子(深圳) 86-755-83298787
Http://www.100y.com.tw

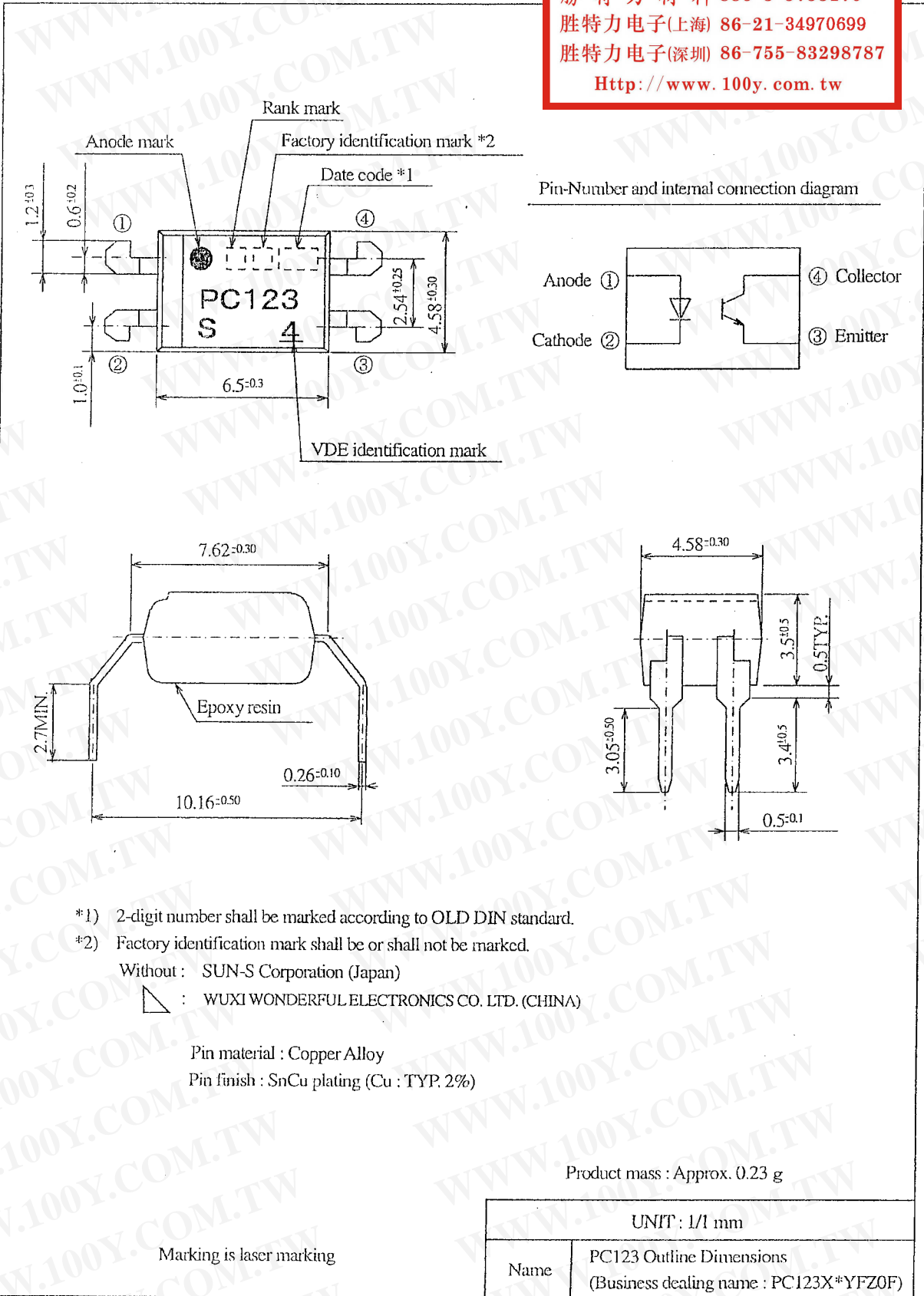

*1) 2-digit number shall be marked according to OLD DIN standard.

*2) Factory identification mark shall be or shall not be marked.

Without : SUN-S Corporation (Japan)

: WUXI WONDERFUL ELECTRONICS CO. LTD. (CHINA)

Pin material : Copper Alloy

Pin finish : SnCu plating (Cu : TYP. 2%)

Product mass : Approx. 0.23 g

Marking is laser marking

UNIT : 1/1 mm	
Name	PC123 Outline Dimensions (Business dealing name : PC123X*YFZ0F)

PC123X1YFZ0F
REFERENCE

Method of Diagram 1: Breakdown test (Apply to type test and sampling test)

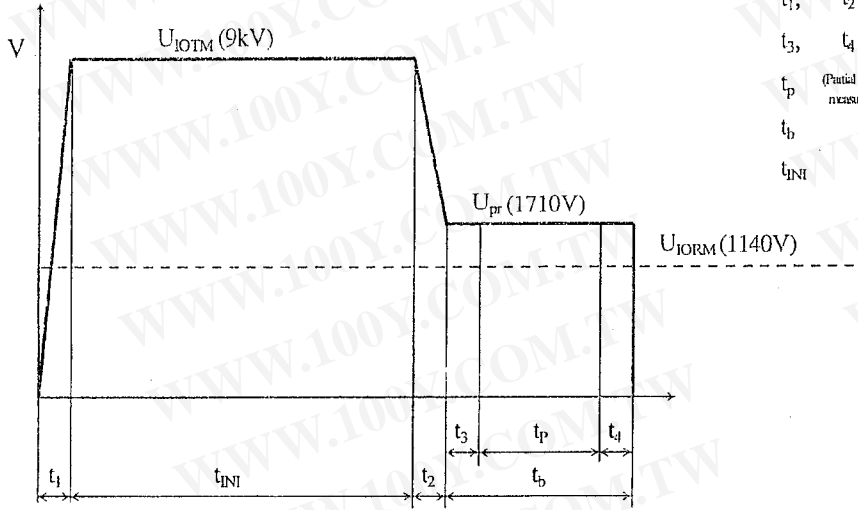

- t_1, t_2 = 1 to 10 s
- t_3, t_4 = 1 s
- t_p (Partial discharge measuring time) = 10 s
- t_b = 12 s
- t_{NI} = 60 s

Method of Diagram 2: Non breakdown test (Apply to all device test)

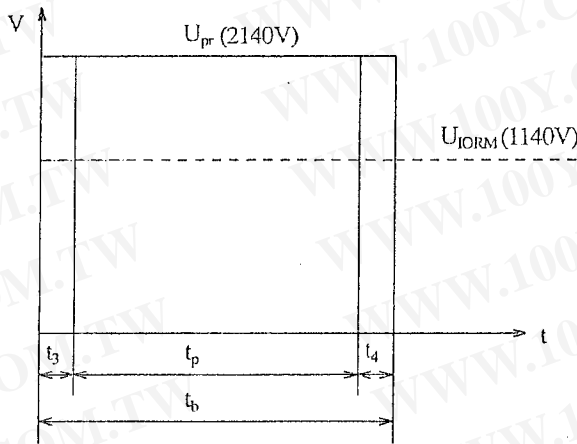

- t_3, t_4 = 0.1 s
- t_p (Partial discharge measuring time) = 1 s
- t_b = 1.2 s

勝特力材料 886-3-5753170
勝特力电子(上海) 86-21-34970699
勝特力电子(深圳) 86-755-83298787
[Http://www.100y.com.tw](http://www.100y.com.tw)

(Fig.6) Safety maximum power dissipation vs. ambient temperature (When failed)

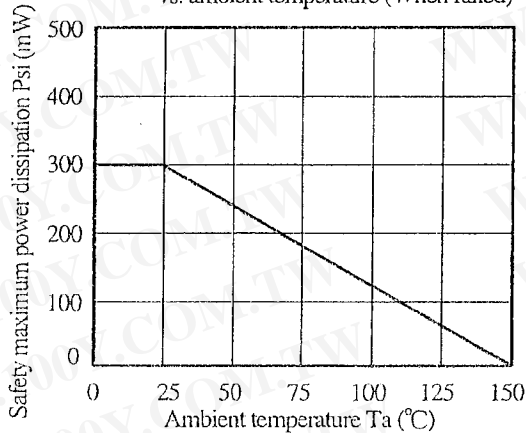

(Fig. 7) Safety maximum forward current vs. ambient temperature (When failed)

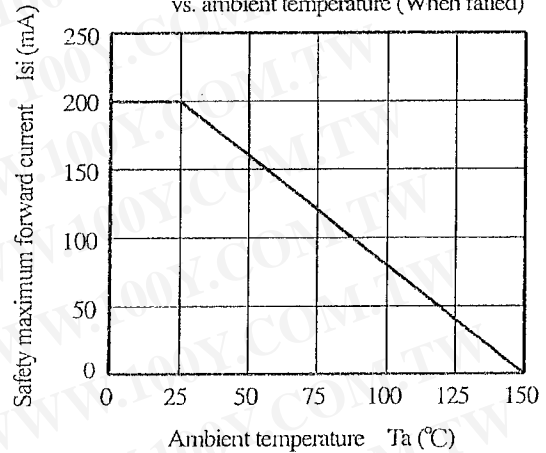

Opto Specification

Opto/EC Group



NORTH AMERICA

Sharp Microelectronics of the Americas
5700 NW Pacific Rim Blvd.
Camas, WA 98607, U.S.A.
Phone: (1) 360-834-2500
Fax: (1) 360-834-8903
www.sharpsma.com

TAIWAN

Sharp Electronic Components
(Taiwan) Corporation
8F-A, No. 16, Sec. 4, Nanking E. Rd.
Taipei, Taiwan, Republic of China
Phone: (886) 2-2577-7341
Fax: (886) 2-2577-7326/2-2577-7328

CHINA

Sharp Microelectronics of China
(Shanghai) Co., Ltd.
28 Xin Jin Qiao Road King Tower 16F
Pudong Shanghai, 201206 P.R. China
Phone: (86) 21-5854-7710/21-5834-6056
Fax: (86) 21-5854-4340/21-5834-6057
Head Office:
No. 360, Bashen Road,
Xin Development Bldg. 22
Waigaoqiao Free Trade Zone Shanghai
200131 P.R. China
Email: smc@china.global.sharp.co.jp

EUROPE

Sharp Microelectronics Europe
Division of Sharp Electronics (Europe) GmbH
Sonninstrasse 3
20097 Hamburg, Germany
Phone: (49) 40-2376-2286
Fax: (49) 40-2376-2232
www.sharpsme.com

SINGAPORE

Sharp Electronics (Singapore) PTE., Ltd.
438A, Alexandra Road, #05-01/02
Alexandra Technopark,
Singapore 119967
Phone: (65) 271-3566
Fax: (65) 271-3855

KOREA

Sharp Electronic Components
(Korea) Corporation
RM 501 Geosung B/D, 541
Dohwa-dong, Mapo-ku
Seoul 121-701, Korea
Phone: (82) 2-711-5813 ~ 8
Fax: (82) 2-711-5819

JAPAN

Sharp Corporation
Electronic Components & Devices
22-22 Nagaïke-cho, Abeno-Ku
Osaka 545-8522, Japan
Phone: (81) 6-6621-1221
Fax: (81) 6117-725300/6117-725301
www.sharp-world.com

HONG KONG

Sharp-Roxy (Hong Kong) Ltd.
Level 26, Tower 1, Kowloon Commerce Centre,
No. 51, Kwai Cheong Road, Kwai Chung,
New Territories, Hong Kong
Phone: (852) 28229311
Fax: (852) 28660779
www.sharp.com.hk
Shenzhen Representative Office:
Room 602-603, 6/F,
International Chamber of Commerce Tower,
168 Fuhua Rd. 3, CBD,
Futian District, Shenzhen 518048,
Guangdong, P.R. China
Phone: (86) 755-88313505
Fax: (86) 755-88313515

勝特力材料 886-3-5753170
勝特力电子(上海) 86-21-34970699
勝特力电子(深圳) 86-755-83298787
Http://www.100y.com.tw

SPECIFICATIONS ARE SUBJECT TO CHANGE WITHOUT NOTICE.
Suggested applications (if any) are for standard use; See Important Restrictions for limitations on special applications. See Limited Warranty for SHARP's product warranty. The Limited Warranty is in lieu, and exclusive of, all other warranties, express or implied. ALL EXPRESS AND IMPLIED WARRANTIES, INCLUDING THE WARRANTIES OF MERCHANTABILITY, FITNESS FOR USE AND FITNESS FOR A PARTICULAR PURPOSE, ARE SPECIFICALLY EXCLUDED. In no event will SHARP be liable, or responsible in any way, for any incidental or consequential economic or property damage.