

勝特力材料 886-3-5753170  
勝特力电子(上海) 86-21-34970699  
勝特力电子(深圳) 86-755-83298787  
[Http://www.100y.com.tw](http://www.100y.com.tw)

# MIL-DTL-5015系列螺纹连接 圆形电连接器



# MIL-DTL-5015系列螺纹连接圆形电连接器

## 概述

该系列连接器参照美军标 MIL-C-5015 设计，具有良好的导电性、抗电磁性和耐腐蚀性，接触件采用冠簧结构，具有优良的接触性能，连接方式为螺纹连接。产品使用方便，快速插拔，规格齐全，广泛应用于各种电子电气设备之间的电路连接，可与国外同类产品互换对接使用。

## 适用标准

产品符合 GJB 600A 《螺纹连接圆形电连接器总规范》及 GJB 1612 《GJB 600 螺纹连接圆形电连接器的绝缘安装板接触件孔位排列》。

## 壳体

壳体包括耐环境的主壳体和后附件，具有防潮和密封性。主壳体有如下类型：墙外插座 (MS3100)、连线插头 (MS3101)、盒式安装插座 (3102)、直管插头 (3106)，90° 弯管插头 (3108)。后附件包括电缆夹 (3057)、橡胶套管 (3420) 等。

外壳材料为铝合金，作涂橄榄绿或黑色环保漆处理，其它金属零件采用耐腐蚀不锈钢材料。



## 插芯

绝缘体采用海灰色硅橡胶，具有良好的绝缘性和耐高温性，密封圈采用黑色丁腈橡胶。

## 接触件

插针和插孔材料为铜合金，表面作镀银处理，焊接方式。若客户需要可作镀金处理。

## 规格型号

电连接器的型号命名如下：

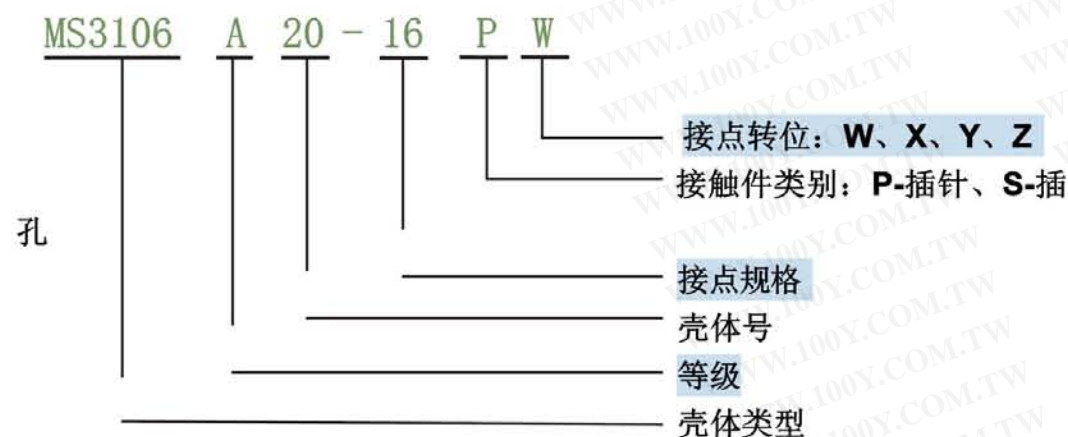

## 工作环境

温度：-55℃~+125℃；

湿度：40℃±2℃时，湿度为92%~95%；

焊接温度：可承受260℃，10s

## 电气特性

### 使用等级

使用等级	额定电压		耐压
仪器	250 AC.V	200 AC.V	1000 AC.V
A	700 AC.V	500 AC.V	2000 AC.V
D	1250 AC.V	900 AC.V	2800 AC.V
E	1750 AC.V	1250 AC.V	3500 AC.V
B	2450 AC.V	1750 AC.V	4500 AC.V
C	4200 AC.V	3000 AC.V	7000 AC.V

## 接触件额定值及线径

接触件代码	工作电流	额定电流	电压压降	线径
16#	13A	20A	21	1.25mm <sup>2</sup> max
12#	23A	35A	20	3.5mm <sup>2</sup> max
8#	46A	60A	12	8mm <sup>2</sup> max
4#	80A	110A	10	22mm <sup>2</sup> max
0#	150A	200A	10	50mm <sup>2</sup> max

绝缘电阻：5000MΩ

## 机械性能

机械寿命不小于500次

## 外形尺寸图

墙外插座 MS3100 A/R Type (Wall Mount receptacle)

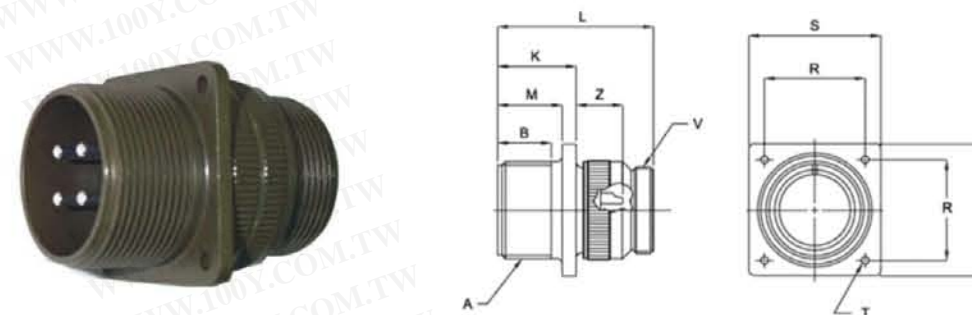

尺寸 mm										
壳体号	A 螺纹-2A	B Min	K ±0.02	L ±0.5	M ±0.2	R ±0.1	S ±0.2	T ±0.1	V 螺纹-2A	Z ±1.5
10SL	0.625-24 UNEF	10.0	17.2	40.0	14.4	18.2	25.4	3.2	0.625-24 UNEF	10.85
14S	0.875-20 UNEF	10.0	17.6	40.0	14.4	23.0	30.0	3.2	0.750-20 UNEF	10.45
16S	1.000-20 UNEF	10.0	17.6	40.0	14.4	24.6	32.5	3.2	0.875-20 UNEF	10.45
16	1.000-20 UNEF	16.2	22.4	51.2	19.2	24.6	32.5	3.2	0.875-20 UNEF	16.50

壳体号	A 螺纹-2A	B Min	K ±0.02	L ±0.5	M ±0.2	R ±0.1	S ±0.2	T ±0.1	V 螺纹-2A	Z ±1.5
18	1.125-18 UNEF	16.2	23.1	51.2	19.2	27.0	35.0	3.2	1.000-20 UNEF	15.80
20	1.250-18 UNEF	16.2	23.1	51.2	19.2	29.4	38.0	3.2	1.1875-18 UNE	15.80
22	1.375-18 UNEF	16.2	23.1	51.2	19.2	31.8	41.0	3.2	1.1875-18 UNE	15.80
24	1.500-18 UNEF	16.2	24.7	52.5	20.8	34.9	44.5	3.7	1.4375-18 UNE	14.20
28	1.750-18 UNS	16.2	24.7	60.5	20.8	39.7	50.8	3.7	1.4375-18 UNE	14.20
32	2.000-18 UNS	17.5	26.3	63.9	22.4	44.5	57.0	4.3	1.750-18 UNS	12.60
36	2.250-16 UN	17.5	26.3	67.1	22.4	49.2	63.5	4.3	2.000-18 UNS	12.60

连线插座 MS3101 A/R Type

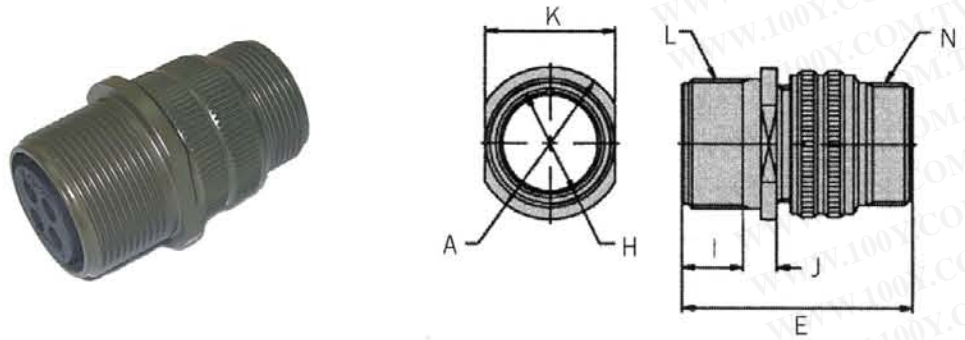

尺寸 mm								
壳体号	ΦA Max	E Max	ΦH +0.38 -0.00	I Min	J Max	K Max	L(-2A), M(-2B) 螺纹	N 螺纹-2A
10SL	24.61	38.88	11.38	9.53	1.57	16.66	0.625-24 UNEF	0.625-24 UNEF
14S	29.36	42.87	17.33	9.53	1.83	22.60	0.875-20 UNEF	0.75-20 UNEF
16S	31.75	42.87	20.50	9.53	1.83	25.78	1-20 UNEF	0.875-20 UNEF
16	31.75	52.37	20.50	15.88	1.98	25.78	1-20 UNEF	0.875-20 UNEF
18	34.13	52.37	23.68	15.88	2.77	28.95	1.125-18 UNEF	1-20 UNEF
20	37.31	55.57	26.88	15.88	2.77	32.13	1.25-18 UNEF	1.1875-18 UNEF

壳体号	ΦA max	E max	ΦH +0.38 -0.00	I min	J max	K max	L(-2A), M(-2B) 螺纹	N 螺纹-2A
22	40.48	55.57	30.03	15.88	2.97	35.30	1.375-18 UNEF	1.1875-18 UNEF
24	43.66	58.72	33.20	15.88	2.97	38.48	1.5-18 UNEF	1.4375-18 UNEF
28	50.01	58.72	38.77	15.88	2.97	44.83	1.75-18 UNS	1.4375-18 UNEF
32	56.36	61.92	45.12	15.88	2.97	51.18	2-18 UNS	1.75-18 UNS
36	62.71	61.92	50.68	15.88	2.97	57.65	2.25-16 UN	2-18 UNS

盒式安装插座 MS3102 A/R Type (Box Mount Receptacle)

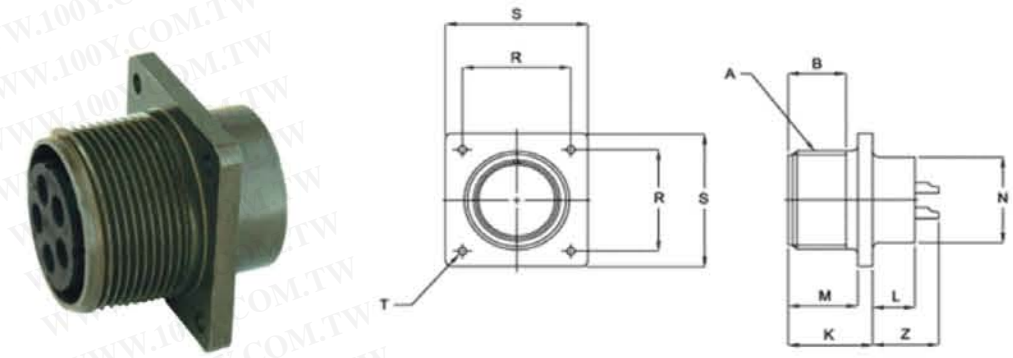

尺寸 mm										
壳体号	A 螺纹-2A	B Min.	K ±0.2	L ±0.1	M ±0.1	N ±0.1	R ±0.1	S ±0.2	T ±0.1	Z ±1.5
10SL	0.625-24 UNEF	10.0	17.2	7.5	14.4	16.0	18.2	25.4	3.2	10.85
14S	0.875-20 UNEF	10.0	17.6	7.1	14.4	19.15	23.0	30.0	3.2	10.45
16S	1.000-20 UNEF	10.0	17.6	7.1	14.4	22.35	24.6	32.5	3.2	10.45
16	1.000-20 UNEF	16.2	22.4	12.1	19.2	22.35	24.6	32.5	3.2	16.5
18	1.125-18 UNEF	16.2	23.1	11.4	19.2	25.6	27.0	35.0	3.2	15.8

壳体号	A 螺纹-2A	B Min.	K ±0.2	L ±0.1	M ±0.1	N ±0.1	R ±0.1	S ±0.2	T ±0.1	Z ±1.5
20	1.250-18 UNEF	16.2	23.1	11.4	19.2	28.7	29.4	38.0	3.2	15.8
22	1.375-18 UNEF	16.2	23.1	11.4	19.2	31.9	31.8	41.0	3.2	15.8
24	1.500-18 UNEF	16.2	24.7	11.1	20.8	35.1	34.9	44.5	3.7	14.2
28	1.750-18 UNS	16.2	24.7	11.1	20.8	41.4	39.7	50.8	3.7	14.2
32	2.000-18 UNS	17.5	26.3	11.1	22.4	47.75	44.5	57.0	4.3	12.6
36	2.250-16 UN	17.5	26.3	11.1	22.4	52.5	49.2	63.5	4.3	12.6

直管插头 MS3106 A/R Type (Straight Plug)

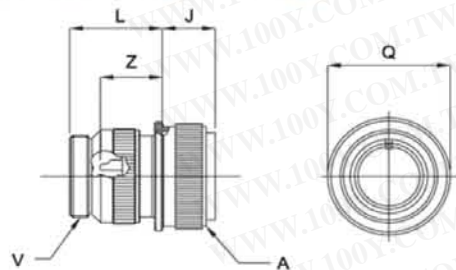

尺寸 mm						
壳体号	A 螺纹-2A	J ±0.1	L ±0.5	Q ±0.5	V 螺纹-2A	Z ±1.5
10SL	0.625-24 UNEF	13.5	26.5	23.0	0.625-24 UNEF	14.5
14S	0.875-20 UNEF	13.5	26.5	28.0	0.750-20 UNEF	14.5
16S	1.000-20 UNEF	13.5	26.5	31.5	0.875-20 UNEF	14.5
16	1.000-20 UNEF	18.2	33.0	31.5	0.875-20 UNEF	20.7
18	1.125-18 UNEF	18.2	33.0	34.1	1.000-20 UNEF	20.7
20	1.250-18 UNEF	18.2	33.0	37.3	1.1875-18 UNEF	20.7
22	1.375-18 UNEF	18.2	33.0	40.3	1.1875-18 UNEF	20.7
24	1.500-18 UNEF	18.2	34.3	43.5	1.4375-18 UNEF	20.7
28	1.750-18 UNS	18.2	42.3	49.4	1.4375-18 UNEF	20.7
32	2.000-18 UNS	18.2	45.7	56.2	1.750-18 UNS	20.7
36	2.250-16 UN	18.2	48.9	62.7	2.000-18 UNS	20.7

弯管插头 MS3108 A/R Type (90 ° Cable Plug)

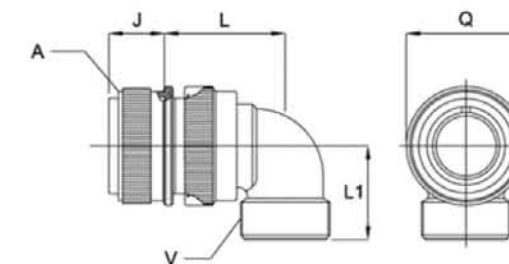

尺寸 mm						
壳体号	A 螺纹-2A	J ±0.1	L ±0.5	L1 ±0.5	Q ±.5	V 螺纹-2B
10SL	0.625-24 UNEF	13.5	24.9	24.0	23.0	0.625-24 UNEF
14S	0.875-20 UNEF	13.5	26.4	26.2	28.0	0.750-20 UNEF
16S	1.000-20 UNEF	13.5	29.7	27.8	31.5	0.875-20 UNEF
16	1.000-20 UNEF	18.2	34.8	27.8	31.5	0.875-20 UNEF
18	1.125-18 UNEF	18.2	37.5	30.2	34.1	1.000-20 UNEF
20	1.250-18 UNEF	18.2	40.5	31.8	37.3	1.1875-18 UNEF
22	1.375-18 UNEF	18.2	43.1	33.5	40.3	1.1875-18 UNEF
24	1.500-18 UNEF	18.2	44.3	35.0	43.5	1.4375-18 UNEF
28	1.750-18 UNS	18.2	16.6	37.5	49.9	1.4375-18 UNEF
32	2.000-18 UNS	18.2	52.4	43.5	56.2	1.750-18 UNS
36	2.250-16 UN	18.2	56.4	46.5	62.7	2.000-18 UNS

插头防护盖 MS25042 (Dust Caps for Plug Connectors)



尺寸 mm						
产品规格	壳体号	A	B ±0.3	C ±0.3	D	E
MS25042-10D	10SL	0.625-24	16.15	17.3	4.0	102
MS25042-14D	14 - 14S	0.876-20	20.9	23.5	4.0	115
MS25042-16D	16 - 16S	1.000-20	20.9	26.8	4.0	115
MS25042-18D	18	1.125-18	20.9	30.0	4.0	115
MS25042-20D	20	1.250-18	20.9	32.8	4.8	127
MS25042-22D	22	1.375-18	20.9	36.3	4.8	127
MS25042-24D	24	1.500-18	20.9	39.5	4.8	140
MS25042-28D	28	1.750-18	20.9	45.8	4.8	197
MS25042-32D	32	2.000-18	20.9	52.2	5.5	197
MS25042-36D	36	2.250-16	20.9	58.5	5.5	197

插座防护盖 MS25043 (Dust Caps for Receptacle)

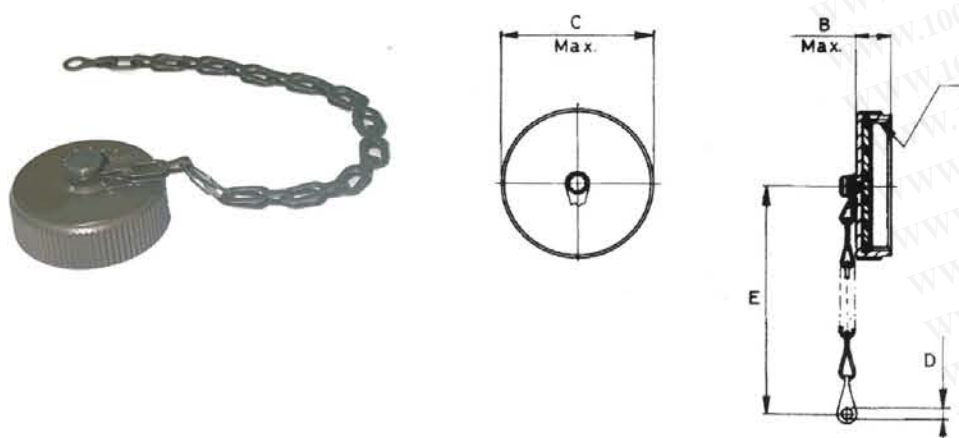

尺寸 mm						
产品规格	壳体号	A	B ±0.3	C ±0.3	D	E
MS25043-10D	10SL	0.625-24	11.50	20.1	3.60	102
MS25043-14D	14 - 14S	0.876-20	11.50	26.9	3.60	115
MS25043-16D	16 - 16S	1.000-20	11.50	29.8	3.60	115
MS25043-18D	18	1.125-18	11.50	33.0	3.60	115
MS25043-20D	20	1.250-18	11.50	36.25	3.60	127
MS25043-22D	22	1.375-18	11.50	39.85	3.60	127
MS25043-24D	24	1.500-18	11.50	43.0	4.25	140
MS25043-28D	28	1.750-18	13.45	49.2	4.25	197
MS25043-32D	32	2.000-18	13.45	55.5	4.80	197
MS25043-36D	36	2.250-16	13.45	62.2	4.80	197

电缆夹 MS3057A (Cable Strain Relief Clamp)

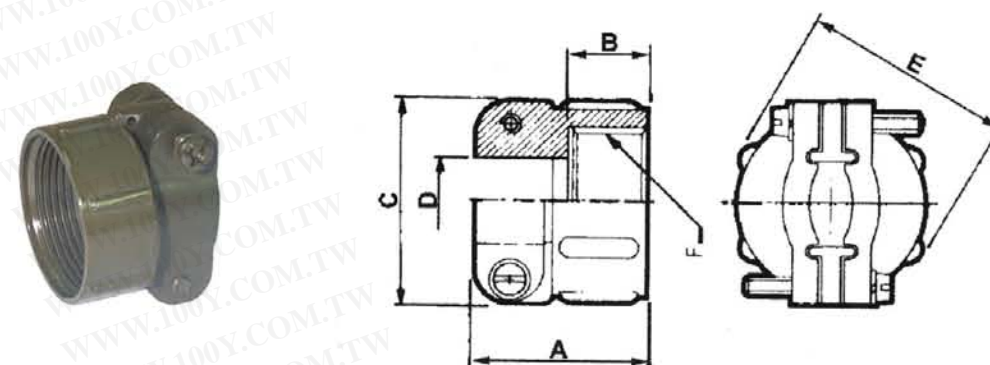

尺寸 mm							
产品规格	适用壳体号	配用夹线板规格	A ±0.8	B	D Max	E-C ±0.8	F 螺纹-2B
MS3057-4A	10SL-12-12S	MS3420-4	20.6	10.5	8.0	22.2	0.625-24 UNEF
MS3057-6A	14-14S	MS3402-6	22.2	10.5	11.0	27.0	0.750-20 UNEF
MS3057-8A	16-16S	MS3420-8	24.0	10.5	14.2	29.0	0.850-20 UNEF
MS3057-10A	18	MS3420-10	24.0	10.5	15.8	33.0	1.000-20 UNEF
MS3057-12A	20-22	MS3420-12	24.0	10.5	19.0	37.0	1.1875-18 NEF
MS3057-16A	24-28	MS3420-16	26.0	10.5	23.8	43.0	1.4375-18 NEF
MS3057-20A	32	MS3420-20	27.8	12.5	31.8	51.6	1.750-18 NS
MS3057-24A	36	MS3420-24	29.4	13.5	35.0	58.0	2.000-18 NS

橡胶套管 MS3420 Neoprene Sleeves and Sealing Plugs

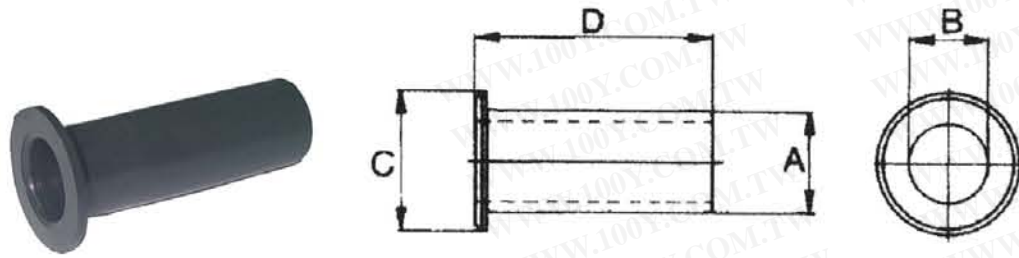

尺寸 mm					
产品规格	适用电缆夹	A	B	C	D
MS3420-3	MS3057-3A	5.30	3.30	9.50	73.0
MS3420-4	MS3057-4A	7.60	5.60	12.8	70.0
MS3420-6	MS3057-6A	10.8	7.90	15.7	67.0
MS3420-8	MS3057-8A	14.0	11.1	18.8	64.0
MS3420-10	MS3057-10A	15.6	14.3	22.0	61.0
MS3420-12	MS3057-12A	18.8	15.9	26.9	57.0
MS3420-16	MS3057-16A	23.5	19.1	33.3	53.0
MS3420-20	MS3057-20A	31.5	23.8	40.5	50.0
MS3420-24	MS3057-24A	34.6	31.8	47.0	47.0
MS3420-28	MS3057-28A	41.0	35.0	53.0	44.0

接触规格:

接触规格	接触件数量	使用等级	接触件规格					接触规格	接触件数量	使用等级	接触件规格				
			0	4	8	12	16				0	4	8	12	16
10SL-3	3	A					3	22-7	1	E					1
10SL-4	2	A					2	22-10	4	E					4
14S-1	3	A					3	22-14	19	A					19
14S-2	4	Inst.					4	22-19	14	A					14
14S-5	5	Inst.					5	22-22	4	A			4		
14S-6	6	Inst.					6	22-23	8	A/d		8			
14S-7	3	A					3	24-2	7	D				7	
14S-9	2	A					2	24-6	8	A/D				8	
16S-1	7	A					7	24-7	16	A				2	14
16S-4	2	D					2	24-10	7	A			7		
16S-5	3	A					3	24-11	9	A			3	6	
16S-8	5	A					5	24-12	5	A		2		3	
16-9	4	A				2	2	24-20	11	D				2	9
16-10	3	A				3		24-22	4	D			4		
16-11	2	A				2		24-28	24	Inst.					24
18-1	10	A/Inst.					10	28-6	3	D		3			
18-3	2	D				2		28-9	12	D				6	6
18-4	4	D					4	28-10	7	A/D		2	2	3	
18-5	3	D				2	1	28-11	22	A				4	18
18-8	8	A				1	7	28-12	26	A					26
18-9	7	Inst.				2	5	28-15	35	A					35
18-10	4	A				4		28-17	15	A/B/D					15
18-11	5	A				5		28-19	10	A/B/D				4	6
18-12	6	A					6	28-20	14	A				10	4
18-19	10	A					10	28-21	37	A					37
18-20	5	A					5	28-22	6	D		3			3
18-22	3	D					3	32-1	5	D/E	2			3	
20-3	3	D				3		32-6	23	A		2	3	2	16
20-4	4	D				4		32-7	35	A/Inst.				7	28
20-11	13	Inst.					13	32-8	30	A				6	24
20-15	7	A				7		32-15	8	D	2			6	
20-16	9	A				2	7	32-17	4	D		4			
20-17	6	A				5	1	32-22	54	A					54
20-18	9	A				3	6	36-1	22	D				4	18
20-19	3	A				3		36-3	6	D	3			3	

接点规格	接触件数量	使用等级	接触件规格					接点规格	接触件数量	使用等级	接触件规格				
			0	4	8	12	16				0	4	8	12	16
20-23	2	A			2		36-4	3	A/D	3					
20-27	14	A				14	36-5	4	A	4					
20-29	17	A				17	36-7	47	A			7	40		
20-33	11	A				11	36-8	47	A			1	46		
22-1	8	D			8		36-9	31	A		1	2	14		
22-2	3	D			3		36-10	48	A				48		
22-5	6	D				2	4								

绝缘体转位 (防误插):

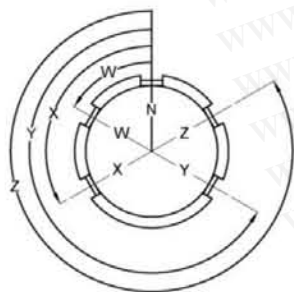

接点规格	转位				接点规格	转位			
	W	X	Y	Z		W	X	Y	Z
10SL-3	-	-	-	-	22-7	-	-	-	-
10SL-4	-	-	-	-	22-10	35	110	250	325
14S-1					22-14	80	110	250	280
14S-2	-	120	240	-	22-19	80	110	250	280
14S-5	-	110	-	-	22-22	-	110	250	-
14S-6	-	-	-	-	22-23	35	-	250	-
14S-7	90	180	270	-	24-2	80	-	-	280
14S-9	70	145	215	290	24-6	-	110	250	280
16S-1	80	-	-	280	24-7	80	110	250	280
16S-4					24-10	80	-	-	280
16S-5	70	145	215	290	24-11	35	110	250	325
16S-8	-	170	265	-	24-12	80	110	250	280
16-9	35	110	250	325	24-20	80	110	250	280
16-10	90	180	270	-	24-22	45	110	250	-
16-11	35	110	250	325	24-28	80	110	250	280
18-1	70	145	215	290	28-6	70	145	215	290
18-3	35	110	250	325	28-9	80	110	250	280
18-4	35	110	250	325	28-10	80	110	250	280

接点规格	转位				接点规格	转位			
	W	X	Y	Z		W	X	Y	Z
18-5	80	110	250	280	28-11	80	110	250	280
18-8	70	-	-	290	28-12	90	180	270	-
18-9	80	110	250	280	28-15	80	110	250	280
18-10	-	120	240	-	28-17	80	110	250	280
18-11	-	170	265	-	28-19	80	110	250	280
18-12	80	-	-	280	28-20	80	110	250	280
18-19	-	-	-	-	28-21	80	110	250	280
18-20	90	180	270	-	28-22	70	145	215	290
18-22	70	145	215	290	32-1	80	110	250	280
20-3	70	145	215	290	32-6	80	110	250	280
20-4	45	110	250	-	32-7	80	125	235	280
20-11	-	-	-	-	32-8	80	125	235	280
20-15	80	-	-	280	32-15	35	110	250	280
20-16	80	110	250	280	32-17	45	110	250	-
20-17	90	180	270	-	32-22				
20-18	35	110	250	325	36-1	80	110	250	280
20-19	90	180	270	-	36-3	70	145	215	290
20-23	35	110	250	325	36-4	70	145	215	290
20-27	35	110	250	325	36-5	-	120	240	-
20-29	80	-	-	280	36-7	80	110	250	280
20-33	-	-	-	-	36-8	80	125	235	280
22-1	35	110	250	325	36-9	80	125	235	280
22-2	70	145	215	290	36-10	80	125	235	280
22-5	35	110	250	325					

胜特力材料 886-3-5753170  
 胜特力电子(上海) 86-21-34970699  
 胜特力电子(深圳) 86-755-83298787  
[Http://www.100y.com.tw](http://www.100y.com.tw)